

TECHNICAL DATA

DN620

Designers' Data Sheet
LOW NOISE CHARGE SENSITIVE
PREAMPLIFIER

The DN620 is a low noise Charge Sensitive Inverting Preampifier for use with detectors with capacitance from less than one to several thousand picofarads. This includes detectors such as photodiodes, pyroelectric devices photomultipliers, as well as other sensors that give up charge when stimulated.

Housed in a TO-99 Package, the input stage of this hybrid circuit amplifier is a low noise Junction FET. A 1 pF capacitor in parallel with a 1,000 MΩ resistor provides internal feedback which gives the amplifier an initial sensitivity of one volt output per picocoulomb of input charge. The gain and frequency response of the amplifier can be modified by adding external feedback components. The internal feedback components can also be factory selected to meet a customer's specific needs.

FEATURES

- Low Noise
- Internal Gain Set Components
- < 20 Nano Second Rise Time
- External Frequency Compensation Adjustment

APPLICATIONS

- Piezoelectric Amplifiers
- Electrometer Amplifier
- Solid State Photo Detectors
- Capacitive Microphone Amplifier
- Nuclear Monitoring
- Pyroelectric Detectors
- Hydrophones
- Ultrasonic Transducers

SIMPLIFIED SCHEMATIC DIAGRAM

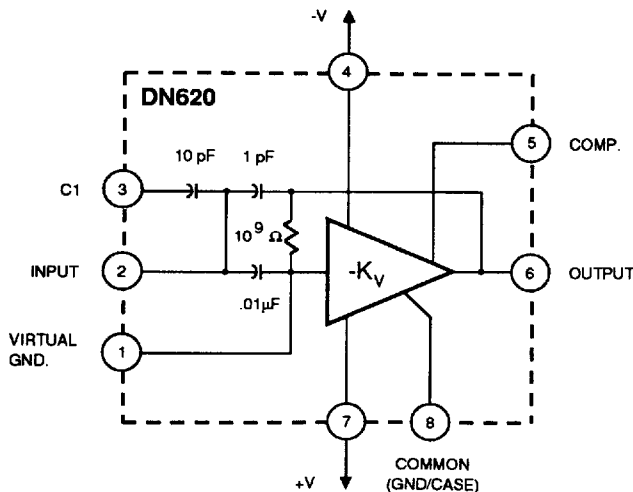

PIN CONFIGURATION

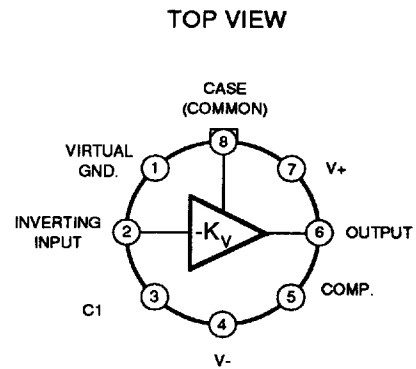

TO-99 METAL PACKAGE

ABSOLUTE MAXIMUM RATINGS

Supply Voltage.....±12V
 Internal Power Dissipation.....500mW
 Storage Temperature.....-65°C to +150°C

Operating Temperature.....-25°C to +85°C
 Lead Temperature (Soldering, 10sec).....300°C

ELECTRICAL CHARACTERISTICS ($T_A = 25^\circ\text{C}$ UNLESS OTHERWISE SPECIFIED, $V_{\text{SUPPLY}} = \pm 9\text{V}$)

SYMBOL	CHARACTERISTIC	TEST CONDITIONS	DN620			UNIT
			MIN	TYP	MAX	
G_{vc}	Electron charge Input to Output Voltage Gain (Measured in Volts per pico Coulomb)	See Fig. 1 $C_{fb} = 1.0\text{pF}$	0.8	1.0		V/pC
R_{fb}	Feed Back Resistor			1,000		MΩ
C_{fb}	Internal Feed Back Capacitor C1		0.8	1.0	1.2	pF
C2	Internal Capacitor C2		8	10.0	12	pF
V_O	D.C. Output Voltage (No input signal is present)		-2.0	-1.0	0	Vdc
V_O (p-p)	Maximum Peak to Peak Output Voltage ($f_{in} = 100\text{KHz}$) R load 100,000Ω in parallel with 10pF		8	10		Vp-p
t_r	Output Voltage Rise Time	See Fig. 1 $C = 1.0\text{pF}$	20			nSec
t_f	Output Voltage Fall Time	See Fig. 1 $C = 1.0\text{pF}$	50			nSec
K_V	Open Loop Voltage Gain		70			dB
e_n	Equivalent Input Noise voltage	See Fig. 2				

**GAIN OF 10
INVERTING VOLTAGE
AMPLIFIER**

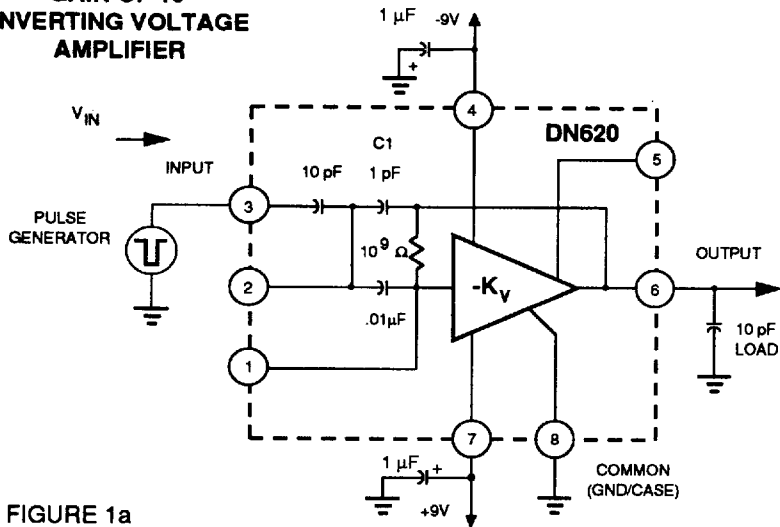

FIGURE 1a

**TYPICAL RISE AND FALL TIMES
FOR THE AMPLIFIER SHOWN IN
FIGURE 1a**

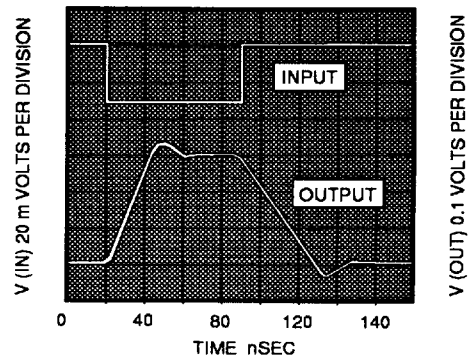

FIGURE 1b

**EQUIVALENT INPUT
NOISE VOLTAGE
MEASUREMENT CIRCUIT**

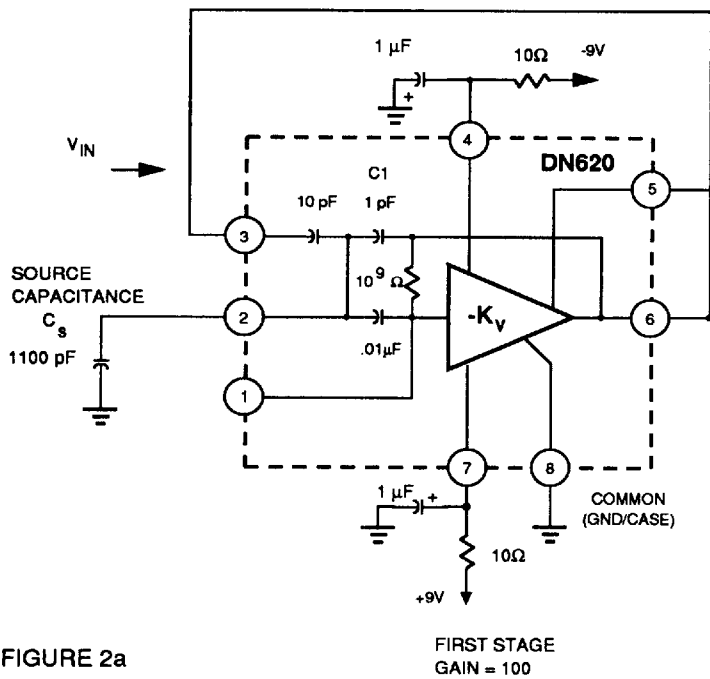

FIGURE 2a

FIRST STAGE
GAIN = 100

**WIDEBAND VOLTAGE NOISE,
DC TO 20 KHz**

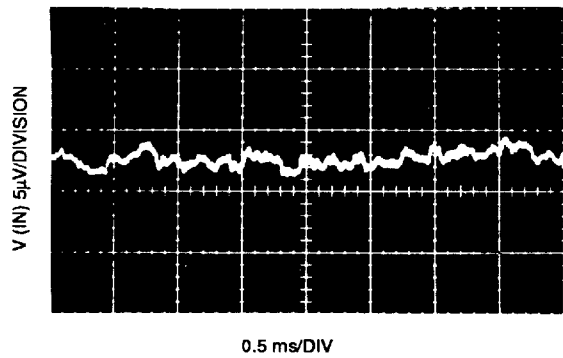
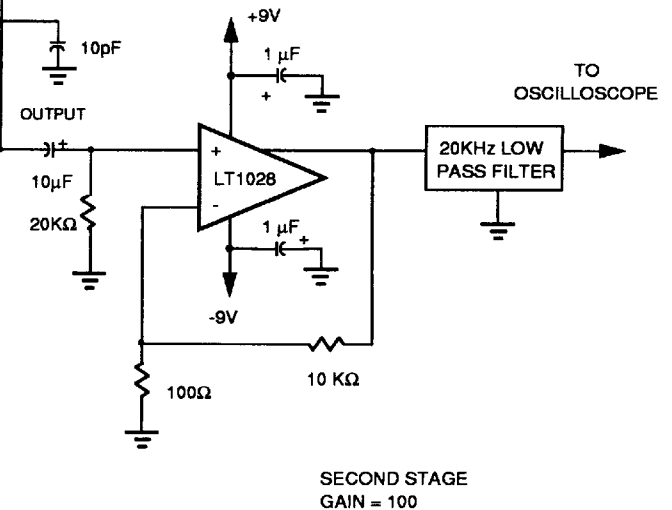
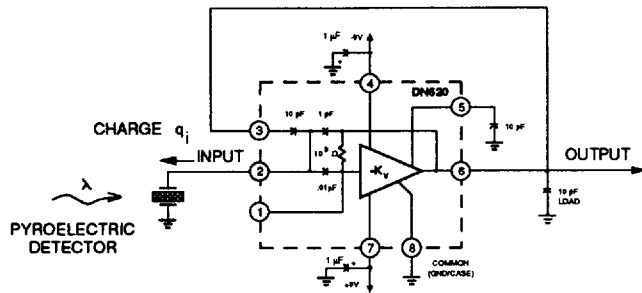

FIGURE 2b



SECOND STAGE
GAIN = 100

PYROELECTRIC DETECTOR AMPLIFIER



GAIN EQUATION

$$e_o = \frac{-q_i}{C_{fb}} = 90 \text{ mV/pC}$$

Where C_{fb} is the feedback capacitor.

$C_{fb} = 11 \text{ pF}$ in the circuit shown.

FIGURE 3

SOLID STATE DETECTOR AMPLIFIER

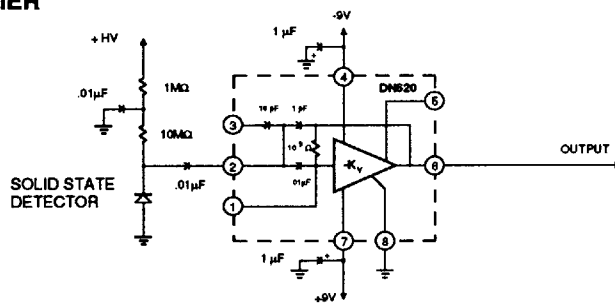
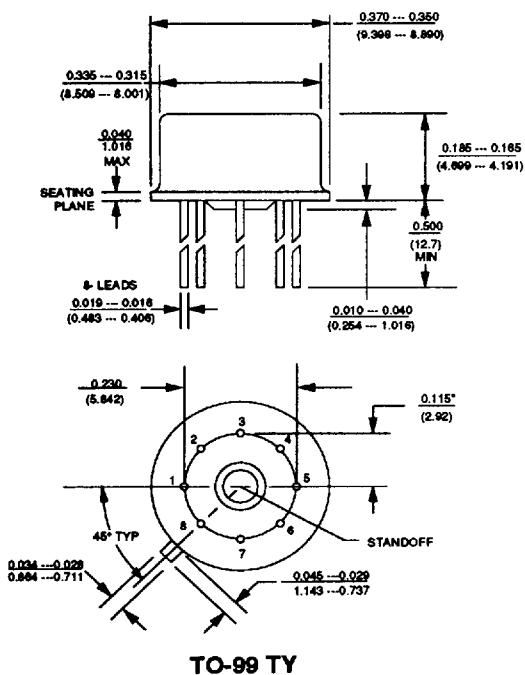
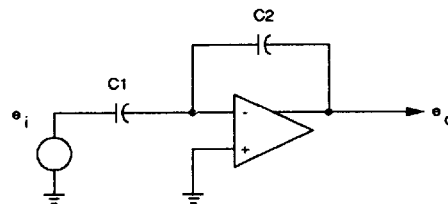

FIGURE 4

PACKAGE DIMENSIONS



GAIN EQUATIONS FOR A TRANSCONDUCTANCE AMPLIFIER WITH CAPACITIVE INPUT AND FEEDBACK ELEMENTS.



$$K_v = - \frac{e_o}{e_i} = - \frac{C_1}{C_2}$$

EXAMPLE:

If $C_1 = 10 \text{ pF}$ and $C_2 = 1,000 \text{ pF}$
then $K_v = -100$

OUTPUT NOISE OF A TRANSCONDUCTANCE AMPLIFIER WITH CAPACITIVE INPUT AND FEEDBACK ELEMENTS.

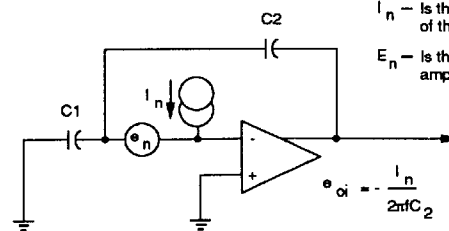

I_n — is the equivalent input current noise of the amplifier.
 E_n — is the equivalent input voltage noise of the amplifier.

$e_{oi} = - \frac{I_n}{2\pi f C_2}$ — This is the output noise of the amplifier due to noise current ($e_n = 0$)

Note that the larger the detector capacitance C_1 the larger the output voltage due to the equivalent amplifier input noise voltage e_n .

$e_{oi} = - e_n \left(1 + \frac{C_1}{C_2} \right)$ — This is the output noise of the amplifier due to noise voltage. ($I_n = 0$)