

TO-220 Plastic Package

CSA614, CSD288

CSA614 PNP PLASTIC POWER TRANSISTOR
CSD288 NPN PLASTIC POWER TRANSISTOR
Low frequency Power Amplifier and Power Regulator

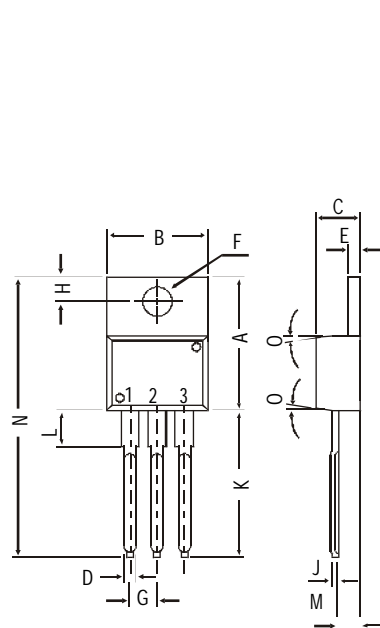

PIN CONFIGURATION
1. BASE
2. COLLECTOR
3. EMITTER
4. COLLECTOR

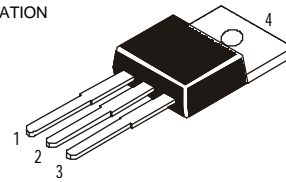

DIM	MIN.	MAX.
A	14.42	16.51
B	9.63	10.67
C	3.56	4.83
D		0.90
E	1.15	1.40
F	3.75	3.88
G	2.29	2.79
H	2.54	3.43
J		0.56
K	12.70	14.73
L	2.80	4.07
M	2.03	2.92
N		31.24
O	DEG 7	

All dimensions in mm.

ABSOLUTE MAXIMUM RATINGS

		614	288
Collector-base voltage (open emitter)	V_{CB0}	max. 80	80 V
Collector-emitter voltage (open base)	V_{CE0}	max. 55	55 V
Collector current	I_C	max.	3.0 A
Total power dissipation up to $T_C = 25^\circ C$	P_{tot}	max.	25 W
Junction temperature	T_j	max.	150 $^\circ C$
Collector-emitter saturation voltage $I_C = 1 A; I_B = 0.1 A$	V_{CEsat}	max. 0.5	1.0 V
D.C. current gain $I_C = 0.5 A; V_{CE} = 5 V$	h_{FE}	min.	40
		max.	240

RATINGS (at $T_A=25^\circ C$ unless otherwise specified)

		614	288
Limiting values			
Collector-base voltage (open emitter)	V_{CB0}	max. 80	80 V
Collector-emitter voltage (open base)	V_{CE0}	max. 55	55 V
Emitter-base voltage (open collector)	V_{EBO}	max.	5.0 V

CSA614, CSD288

Collector current	I_C	max.	3.0	A
Total power dissipation up to $T_C = 25^\circ\text{C}$	P_{tot}	max.	25	W
Junction temperature	T_j	max.	150	$^\circ\text{C}$
Storage temperature	T_{stg}		-65 to +150	$^\circ\text{C}$

CHARACTERISTICS

$T_{amb} = 25^\circ\text{C}$ unless otherwise specified

			614	288
Collector cutoff current				
$I_E = 0; V_{CB} = 50\text{V}$	I_{CBO}	max.	50	μA
Breakdown voltages				
$I_C = 10\text{ mA}; I_B = 0$	V_{CEO}	min.	55	V
$I_C = 500\ \mu\text{A}; I_E = 0$	V_{CBO}	min.	80	V
$I_E = 500\ \mu\text{A}; I_C = 0$	V_{EBO}	min.	5.0	V
Saturation voltage				
$I_C = 1\text{ A}; I_B = 0.1\text{ A}$	V_{CEsat}	max.	0.5	1.0 V
D.C. current gain				
$I_C = 0.5\text{A}; V_{CE} = 5\text{V}^{**}$	h_{FE}	min.	40	
		max.	240	

**** h_{FE} classification: R: 40-80 O: 70-140 Y: 120-240**

Notes

Disclaimer

The product information and the selection guides facilitate selection of the CDIL's Discrete Semiconductor Device(s) best suited for application in your product(s) as per your requirement. It is recommended that you completely review our Data Sheet(s) so as to confirm that the Device(s) meet functionality parameters for your application. The information furnished on the CDIL Web Site/ CD is believed to be accurate and reliable. CDIL however, does not assume responsibility for inaccuracies or incomplete information. Furthermore, CDIL does not assume liability whatsoever, arising out of the application or use of any CDIL product; neither does it convey any license under its patent rights nor rights of others. These products are not designed for use in life saving/support appliances or systems. CDIL customers selling these products (either as individual Discrete Semiconductor Devices or incorporated in their end products), in any life saving/support appliances or systems or applications do so at their own risk and CDIL will not be responsible for any damages resulting from such sale(s).

CDIL strives for continuous improvement and reserves the right to change the specifications of its products without prior notice.



CDIL is a registered Trademark of
Continental Device India Limited

C-120 Naraina Industrial Area, New Delhi 110 028, India.
Telephone + 91-11-579 6150 Fax + 91-11-579 9569, 579 5290
e-mail sales@cdil.com www.cdil.com