

# MCF523x Integrated Microprocessor Hardware Specification

32-bit Embedded Controller Division

The MCF523x is a family of highly-integrated 32-bit microcontrollers based on the V2 ColdFire microarchitecture. Featuring a 16 or 32 channel eTPU, 64 Kbytes of internal SRAM, a 2-bank SDRAM controller, four 32-bit timers with dedicated DMA, a 4 channel DMA controller, up to 2 CAN modules, 3 UARTs and a queued SPI, the MCF523x family has been designed for general purpose industrial control applications. It is also a high-performance upgrade for users of the MC68332. This document provides an overview of the MCF523x microcontroller family, as well as detailed descriptions of the mechanical and electrical characteristics of the devices.

The MCF523x family is based on the Version 2 ColdFire reduced instruction set computing (RISC) microarchitecture operating at a core frequency of up to 150 MHz and bus frequency up to 75 MHz.

## 1 Overview

This 32-bit device's on-chip modules include:

### Table of Contents

1	Overview .....	1
2	Signal Descriptions.....	9
3	Modes of Operation .....	14
4	Design Recommendations .....	17
5	Mechanicals/Pinouts and Part Numbers .....	25
6	Preliminary Electrical Characteristics .....	34
7	Documentation .....	58

Technical Data

© Freescale Semiconductor, Inc., 2004. All rights reserved.

• Preliminary



- V2 ColdFire core with enhanced multiply-accumulate unit (EMAC) providing 144 Dhrystone 2.1 MIPS @ 150 MHz
- eTPU with 16 or 32 channels, 6 Kbytes of code memory and 1.5 Kbytes of data memory with Nexus Class 1 debug support
- 64 Kbytes of internal SRAM
- External bus speed of one half the CPU operating frequency (75 MHz bus @ 150 MHz core)
- 10/100 Mbps bus-mastering Ethernet controller
- 8 Kbytes of configurable instruction/data cache
- Three universal asynchronous receiver/transmitters (UARTs)
- Controller area network 2.0B (FlexCAN) module
  - Optional second FlexCAN module multiplexed with the third UART
- Inter-integrated circuit (I<sup>2</sup>C™) bus controller
- Queued serial peripheral interface (QSPI) module
- Hardware cryptography accelerator (optional)
  - Random number generator
  - DES/3DES/AES block cipher engine
  - MD5/SHA-1/HMAC accelerator
- Four channel 32-bit direct memory access (DMA) controller
- Four channel 32-bit input capture/output compare timers with optional DMA support
- Four channel 16-bit periodic interrupt timers (PITs)
- Programmable software watchdog timer
- Interrupt controller capable of handling up to 126 interrupt sources
- Clock module with integrated phase locked loop (PLL)
- External bus interface module including a 2-bank synchronous DRAM controller
- 32-bit non-multiplexed bus with up to 8 chip select signals that support paged mode Flash memories

## 1.1 MCF523x Family Configurations

Table 1. MCF523x Family Configurations

Module	5232	5233	5234	5235
ColdFire V2 Core with EMAC (Enhanced Multiply-Accumulate Unit)	x	x	x	x
Enhanced Time Processor Unit with memory (eTPU)	16-ch 6K	32-ch 6K	16-ch 6K	32-ch 6K
System Clock	up to 150 MHz			
Performance (Dhrystone/2.1 MIPS)	up to 144			

Table 1. MCF523x Family Configurations (continued)

Module	5232	5233	5234	5235
Instruction/Data Cache	8 Kbytes			
Static RAM (SRAM)	64 Kbytes			
Interrupt Controllers (INTC)	2	2	2	2
Edge Port Module (EPORT)	x	x	x	x
External Interface Module (EIM)	x	x	x	x
4-channel Direct-Memory Access (DMA)	x	x	x	x
SDRAM Controller	x	x	x	x
Fast Ethernet Controller (FEC)	—	—	x	x
Cryptography - Security module for data packets processing	—	—	—	x
Watchdog Timer (WDT)	x	x	x	x
Four Periodic Interrupt Timers (PIT)	x	x	x	x
32-bit DMA Timers	4	4	4	4
QSPI	x	x	x	x
UART(s)	3	3	3	3
I <sup>2</sup> C	x	x	x	x
FlexCAN 2.0B - Controller-Area Network communication module	1	2	1	2
General Purpose I/O Module (GPIO)	x	x	x	x
JTAG - IEEE 1149.1 Test Access Port	x	x	x	x
Package	160 QFP 196 MAPBGA	256 MAPBGA	256 MAPBGA	256 MAPBGA

## 1.2 Block Diagram

The superset device in the MCF523x family comes in a 256 mold array process ball grid array (MAPBGA) package. [Figure 1](#) shows a top-level block diagram of the MCF5235, the superset device.



## 1.3 Features

The following section gives a brief overview of this family's feature set. For more detailed information see the *MCF5235 Reference Manual* (MCF5235RM).

### 1.3.1 Feature Overview

- Version 2 ColdFire variable-length RISC processor core
  - Static operation
  - 32-bit address and data path on-chip
  - Processor core runs at twice the bus frequency
  - Sixteen general-purpose 32-bit data and address registers
  - Implements the ColdFire Instruction Set Architecture, ISA\_A+, with extensions to support the user stack pointer register, and 4 new instructions for improved bit processing
  - Enhanced Multiply-Accumulate (EMAC) unit with four 48-bit accumulators to support 32-bit signal processing algorithms
  - Illegal instruction decode that allows for 68K emulation support
- Enhanced Time Processor Unit (eTPU)
  - Event triggered VLIW processor timer subsystem
  - 32 channels
  - 24-bit timer resolution
  - 6 Kbyte of code memory and 1.5 Kbyte of data memory
  - Variable number of parameters allocatable per channel
  - Double match/capture channels
  - Angle mode support
  - DMA and interrupt request support
  - Nexus Class 1 Debug support
- System debug support
  - Integrated debug supports both ColdFire Debug and Nexus class 1 features on a single port with cross triggering operations for ease of use
  - Unified programming model including both ColdFire and Nexus debug registers
  - Real time trace for determining dynamic execution path
  - Background debug mode (BDM) for in-circuit debugging
  - Real time debug support, with two user-visible hardware breakpoint registers (PC and address with optional data) that can be configured into a 1- or 2-level trigger
- On-chip memories
  - 8-Kbyte cache, configurable as instruction-only, data-only, or split I-/D-cache
  - 64-Kbyte dual-ported SRAM on CPU internal bus, accessible by core and non-core bus

- masters (e.g., DMA, FEC)
- Fast Ethernet Controller (FEC)
  - 10 BaseT capability, half duplex or full duplex
  - 100 BaseT capability, half duplex or full duplex
  - On-chip transmit and receive FIFOs
  - Built-in dedicated DMA controller
  - Memory-based flexible descriptor rings
  - Media independent interface (MII) to external transceiver (PHY)
- FlexCAN Modules (up to 2)
  - Full implementation of the CAN protocol specification version 2.0B
    - Standard Data and Remote Frames (up to 109 bits long)
    - Extended Data and Remote Frames (up to 127 bits long)
    - 0–8 bytes data length
    - Programmable bit rate up to 1 Mbit/sec
  - Flexible Message Buffers (MBs), totalling up to 16 message buffers of 0–8 bytes data length each, configurable as Rx or Tx, all supporting standard and extended messages
  - Unused MB space can be used as general purpose RAM space
  - Listen only mode capability
  - Content-related addressing
  - Three programmable mask registers: global (for MBs 0-13), special for MB14 and special for MB15
  - Programmable transmit-first scheme: lowest ID or lowest buffer number
  - “Time stamp” based on 16-bit free-running timer
  - Global network time, synchronized by a specific message
- Three Universal Asynchronous Receiver Transmitters (UARTs)
  - 16-bit divider for clock generation
  - Interrupt control logic
  - Maskable interrupts
  - DMA support
  - Data formats can be 5, 6, 7 or 8 bits with even, odd or no parity
  - Up to 2 stop bits in 1/16 increments
  - Error-detection capabilities
  - Modem support includes request-to-send ( $\overline{UnRTS}$ ) and clear-to-send ( $\overline{UnCTS}$ ) lines
  - Transmit and receive FIFO buffers
- I<sup>2</sup>C Module
  - Interchip bus interface for EEPROMs, LCD controllers, A/D converters, and keypads

- Fully compatible with industry-standard I<sup>2</sup>C bus
- Master or slave modes support multiple masters
- Automatic interrupt generation with programmable level
- Queued Serial Peripheral Interface (QSPI)
  - Full-duplex, three-wire synchronous transfers
  - Up to four chip selects available
  - Master mode operation only
  - Programmable master bit rates
  - Up to 16 pre-programmed transfers
- Four 32-bit DMA Timers
  - 13-ns resolution at 75 MHz
  - Programmable sources for clock input, including an external clock option
  - Programmable prescaler
  - Input-capture capability with programmable trigger edge on input pin
  - Output-compare with programmable mode for the output pin
  - Free run and restart modes
  - Maskable interrupts on input capture or reference-compare
  - DMA trigger capability on input capture or reference-compare
- Four Periodic Interrupt Timers (PITs)
  - 16-bit counter
  - Selectable as free running or count down
- Software Watchdog Timer
  - 16-bit counter
  - Low power mode support
- Phase Locked Loop (PLL)
  - Crystal or external oscillator reference
  - 8 to 25 MHz reference frequency for normal PLL mode
  - 24 to 75 MHz oscillator reference frequency for 2:1 mode
  - Separate clock output pin
- Interrupt Controllers (x2)
  - Support for up to 110 interrupt sources organized as follows:
    - 103 fully-programmable interrupt sources
    - 7 fixed-level external interrupt sources
  - Unique vector number for each interrupt source
  - Ability to mask any individual interrupt source or all interrupt sources (global mask-all)

## Overview

- Support for hardware and software interrupt acknowledge (IACK) cycles
- Combinatorial path to provide wake-up from low power modes
- DMA Controller
  - Four fully programmable channels
  - Dual-address and single-address transfer support with 8-, 16- and 32-bit data capability along with support for 16-byte ( $4 \times 32$ -bit) burst transfers
  - Source/destination address pointers that can increment or remain constant
  - 24-bit byte transfer counter per channel
  - Auto-alignment transfers supported for efficient block movement
  - Bursting and cycle steal support
  - Software-programmable connections between the 12 DMA requesters in the UARTs (3), 32-bit timers (4) plus external logic (4) the four DMA channels and the eTPU (1)
- External Bus Interface
  - Glueless connections to external memory devices (e.g., SRAM, Flash, ROM, etc.)
  - SDRAM controller supports 8-, 16-, and 32-bit wide memory devices
  - Support for n-1-1-1 burst fetches from page mode Flash
  - Glueless interface to SRAM devices with or without byte strobe inputs
  - Programmable wait state generator
  - 32-bit bidirectional data bus
  - 24-bit address bus
  - Up to eight chip selects available
  - Byte/write enables (byte strobes)
  - Ability to boot from external memories that are 8, 16, or 32 bits wide
- Chip Integration Module (CIM)
  - System configuration during reset
  - Selects one of four clock modes
  - Sets boot device and its data port width
  - Configures output pad drive strength
  - Unique part identification number and part revision number
  - Reset
    - Separate reset in and reset out signals
    - Six sources of reset: Power-on reset (POR), External, Software, Watchdog, PLL loss of clock, PLL loss of lock
    - Status flag indication of source of last reset
- General Purpose I/O interface
  - Up to 142 bits of general purpose I/O



- Bit manipulation supported via set/clear functions
- Unused peripheral pins may be used as extra GPIO
- JTAG support for system level board testing

## 2 Signal Descriptions

This section describes signals that connect off chip, including a table of signal properties. For a more detailed discussion of the MCF523x signals, consult the *MCF5235 Reference Manual* (MCF5235RM).

### 2.1 Signal Properties

Table 2 lists all of the signals grouped by function. The “Dir” column is the direction for the primary function of the pin. Refer to Section 5, “Mechanicals/Pinouts and Part Numbers,” for package diagrams.

#### NOTE

In this table and throughout this document a single signal within a group is designated without square brackets (i.e., A24), while designations for multiple signals within a group use brackets (i.e., A[23:21]) and is meant to include all signals within the two bracketed numbers when these numbers are separated by a colon.

#### NOTE

The primary functionality of a pin is not necessarily its default functionality. Pins that are muxed with GPIO will default to their GPIO functionality.

**Table 2. MCF523x Signal Information and Muxing**

Signal Name	GPIO	Alternate 1	Alternate 2	Dir. <sup>1</sup>	MCF5232 160 QFP	MCF5232 196 MAPBGA	MCF5233 256 MAPBGA	MCF5234 256 MAPBGA	MCF5235 256 MAPBGA
<b>Reset</b>									
$\overline{\text{RESET}}$	—	—	—	I	83	N13	T15	T15	T15
$\overline{\text{RSTOUT}}$	—	—	—	O	82	P13	T14	T14	T14
<b>Clock</b>									
EXTAL	—	—	—	I	86	M14	P16	P16	P16
XTAL	—	—	—	O	85	N14	R16	R16	R16
CLKOUT	—	—	—	O	89	K14	M16	M16	M16
<b>Mode Selection</b>									
CLKMOD[1:0]	—	—	—	I	19,20	G5, H5	J3, J2	J3, J2	J3, J2
$\overline{\text{RCON}}$	—	—	—	I	79	K10	P13	P13	P13
<b>External Memory Interface and Ports</b>									

Table 2. MCF523x Signal Information and Muxing (continued)

Signal Name	GPIO	Alternate 1	Alternate 2	Dir. <sup>1</sup>	MCF5232 160 QFP	MCF5232 196 MAPBGA	MCF5233 256 MAPBGA	MCF5234 256 MAPBGA	MCF5235 256 MAPBGA
A[23:21]	PADDR[7:5]	$\overline{CS}$ [6:4]	—	O	126, 125, 124	B11, C11, D11	B14, C14, A15	B14, C14, A15	B14, C14, A15
A[20:0]	—	—	—	O	123:115, 112:106, 102:98	A12, B12, C12, A13, B13, B14, C13, C14, D12, D13, D14, E11, E12, E13, E14, F12, F13, F14, G11, G12, G13	B15, B16, C15, C16, D16, D15, D14, E16, E15, E14, E13, F15, F14, F13, G15, G14, G13, H16, H15, H14, H13	B15, B16, C15, C16, D16, D15, D14, E16, E15, E14, E13, F15, F14, F13, G15, G14, G13, H16, H15, H14, H13	B15, B16, C15, C16, D16, D15, D14, E16, E15, E14, E13, F15, F14, F13, G15, G14, G13, H16, H15, H14, H13
D[31:16]	—	—	—	O	21:24, 26:30, 33:39	G1, G2, H1, H2, H3, H4, J1, J2, J3, J4, K1, K2, K3, K4, L1, L2	K4, K3, K2, K1, L4, L3, L2, L1, M3, M2, M1, N2, N1, P2, P1, R1	K4, K3, K2, K1, L4, L3, L2, L1, M3, M2, M1, N2, N1, P2, P1, R1	K4, K3, K2, K1, L4, L3, L2, L1, M3, M2, M1, N2, N1, P2, P1, R1
D[15:8]	PDATAH[7:0]	—	—	O	42:49,	M1, N1, M2, N2, P2, L3, M3, N3,	R2, T2, N3, P3, R3, T3, N4, P4,	R2, T2, N3, P3, R3, T3, N4, P4,	R2, T2, N3, P3, R3, T3, N4, P4,
D[7:0]	PDATAL[7:0]	—	—	O	50:52, 56:60	P3, M4, N4, P4, L5, M5, N5, P5	R4, T4, P5, R5, N6, P6, R6, N7	R4, T4, P5, R5, N6, P6, R6, N7	R4, T4, P5, R5, N6, P6, R6, N7
$\overline{BS}$ [3:0]	PBS[7:4]	$\overline{CAS}$ [3:0]	—	O	143:140	B6, C6, D7, C7	C9, B9, A9, A10	C9, B9, A9, A10	C9, B9, A9, A10
$\overline{OE}$	PBUSCTL7	—	—	O	63	N6	T7	T7	T7
$\overline{TA}$	PBUSCTL6	—	—	I	97	H11	K14	K14	K14
$\overline{TEA}$	PBUSCTL5	$\overline{DREQ1}$	—	I	—	J14	K13	K13	K13
R/ $\overline{W}$	PBUSCTL4	—	—	O	96	J13	L16	L16	L16
TSIZ1	PBUSCTL3	$\overline{DACK1}$	—	O	—	P6	N8	N8	N8
TSIZ0	PBUSCTL2	$\overline{DACK0}$	—	O	—	P7	P8	P8	P8
$\overline{TS}$	PBUSCTL1	$\overline{DACK2}$	—	O	—	H13	K16	K16	K16
$\overline{TIP}$	PBUSCTL0	$\overline{DREQ0}$	—	O	—	H12	K15	K15	K15
<b>Chip Selects</b>									
$\overline{CS}$ [7:4]	PCS[7:4]	—	—	O	—	B9, A10, C10, A11	C12, A13, C13, A14	C12, A13, C13, A14	C12, A13, C13, A14
$\overline{CS}$ [3:2]	PCS[3:2]	SD_CS[1:0]	—	O	134,133	A9, C9	B12, D12	B12, D12	B12, D12
$\overline{CS1}$	PCS1	—	—	O	130	B10	B13	B13	B13
$\overline{CS0}$	—	—	—	O	129	D10	D13	D13	D13

Table 2. MCF523x Signal Information and Muxing (continued)

Signal Name	GPIO	Alternate 1	Alternate 2	Dir. <sup>1</sup>	MCF5232 160 QFP	MCF5232 196 MAPBGA	MCF5233 256 MAPBGA	MCF5234 256 MAPBGA	MCF5235 256 MAPBGA
<b>SDRAM Controller</b>									
$\overline{\text{SD\_WE}}$	PSDRAM5	—	—	O	93	K13	L13	L13	L13
$\overline{\text{SD\_SCAS}}$	PSDRAM4	—	—	O	92	K12	M15	M15	M15
$\overline{\text{SD\_SRAS}}$	PSDRAM3	—	—	O	91	K11	M14	M14	M14
SD_CKE	PSDRAM2	—	—	O	139	E8	C10	C10	C10
$\overline{\text{SD\_CS}}[1:0]$	PSDRAM[1:0]	—	—	O	—	L12, L13	N15, M13	N15, M13	N15, M13
<b>External Interrupts Port</b>									
$\overline{\text{IRQ}}[7:3]$	PIRQ[7:3]	—	—	I	IRQ7=64 IRQ4=65	N7, M7, L7, P8, N8	R8, T8, N9, P9, R9	R8, T8, N9, P9, R9	R8, T8, N9, P9, R9
$\overline{\text{IRQ}}_2$	PIRQ2	$\overline{\text{DREQ}}_2$	—	I	—	M8	T9	T9	T9
$\overline{\text{IRQ}}_1$	PIRQ1	—	—	I	66	L8	N10	N10	N10
<b>eTPU</b>									
TPUCH31	—	ECOL	—		—	—	F3	—	F3
TPUCH30	—	ECRS	—		—	—	F4	—	F4
TPUCH29	—	ERXCLK	—		—	—	E3	—	E3
TPUCH28	—	ERXDV	—		—	—	E4	—	E4
TPUCH[27:24]	—	ERXD[3:0]	—		—	—	D3, D4, C3, C4	—	D3, D4, C3, C4
TPUCH23	—	ERXER	—		—	—	D5	—	D5
TPUCH22	—	ETXCLK	—		—	—	C5	—	C5
TPUCH21	—	ETXEN	—		—	—	D6	—	D6
TPUCH20	—	ETXER	—		—	—	C6	—	C6
TPUCH[19:16]	—	ETXD[3:0]	—		—	—	B6, B5, A5, B7	—	B6, B5, A5, B7
TPUCH[15:0]	—	—	—		11, 10, 7:2, 159:154, 152, 151	E2, E1, D1 D2, D3, C1, C2, B1, B2, A2, C3, B3, A3, A4, C4, BR	F2, E1, E2, D1, D2, C1, C2, B1, B2, A2, B3, A3, B4, A4, A6, A7	F2, E1, E2, D1, D2, C1, C2, B1, B2, A2, B3, A3, B4, A4, A6, A7	F2, E1, E2, D1, D2, C1, C2, B1, B2, A2, B3, A3, B4, A4, A6, A7
TCRCLK	PETPU2	—	—		12	E3	F1	F1	F1
UTPUODIS	PETPU1	—	—		—	H10	J13	J13	J13
LTPUODIS	PETPU0	—	—		—	G10	J14	J14	J14
<b>FEC</b>									
EMDIO	PFECI2C2	I2C_SDA	U2RXD	I/O	—	—	—	C7	C7

Table 2. MCF523x Signal Information and Muxing (continued)

Signal Name	GPIO	Alternate 1	Alternate 2	Dir. <sup>1</sup>	MCF5232 160 QFP	MCF5232 196 MAPBGA	MCF5233 256 MAPBGA	MCF5234 256 MAPBGA	MCF5235 256 MAPBGA
EMDC	PFEC12C3	I2C_SCL	U2TXD	O	—	—	—	D7	D7
ECOL	—	—	—	I	—	—	—	F3	F3
ECRS	—	—	—	I	—	—	—	F4	F4
ERXCLK	—	—	—	I	—	—	—	E3	E3
ERXDV	—	—	—	I	—	—	—	E4	E4
ERXD[3:0]	—	—	—	I	—	—	—	D3, D4, C3, C4	D3, D4, C3, C4
ERXER	—	—	—	O	—	—	—	D5	D5
ETXCLK	—	—	—	I	—	—	—	C5	C5
ETXEN	—	—	—	I	—	—	—	D6	D6
ETXER	—	—	—	O	—	—	—	C6	C6
ETXD[3:0]	—	—	—	O	—	—	—	B6, B5, A5, B7	B6, B5, A5, B7
<b>Feature Control</b>									
eTPU/EthENB	—	—	—	I	—	—	—	—	M4
<b>I<sup>2</sup>C</b>									
I2C_SDA	PFEC12C1	CAN0RX	—	I/O	—	J12	L15	L15	L15
I2C_SCL	PFEC12C0	CAN0TX	—	I/O	—	J11	L14	L14	L14
<b>DMA</b>									
DACK[2:0] and DREQ[2:0] do not have a dedicated bond pads. Please refer to the following pins for muxing: $\overline{TS}$ and DT2OUT for $\overline{DACK2}$ , $\overline{TSI2}$ and DT1OUT for $\overline{DACK1}$ , $\overline{TSI0}$ and DT0OUT for $\overline{DACK0}$ , $\overline{IRQ2}$ and DT2IN for $\overline{DREQ2}$ , $\overline{TEA}$ and DT1IN for $\overline{DREQ1}$ , and $\overline{TIP}$ and DT0IN for $\overline{DREQ0}$ .					—	—	—	—	—
<b>QSPI</b>									
QSPI_CS1	PQSPI4	SD_CKE	—	O	—	B7	B10	B10	B10
QSPI_CS0	PQSPI3	—	—	O	147	A6	D9	D9	D9
QSPI_CLK	PQSPI2	I2C_SCL	—	O	148	C5	B8	B8	B8
QSPI_DIN	PQSPI1	I2C_SDA	—	I	149	B5	C8	C8	C8
QSPI_DOUT	PQSPI0	—	—	O	150	A5	D8	D8	D8
<b>UARTs</b>									
U2TXD	PUARTH1	CAN1TX	—	O	—	A8	D11	D11	D11
U2RXD	PUARTH0	CAN1RX	—	I	—	A7	D10	D10	D10
$\overline{U1CTS}$	PUARTL7	$\overline{U2CTS}$	—	I	—	B8	C11	C11	C11

Table 2. MCF523x Signal Information and Muxing (continued)

Signal Name	GPIO	Alternate 1	Alternate 2	Dir. <sup>1</sup>	MCF5232 160 QFP	MCF5232 196 MAPBGA	MCF5233 256 MAPBGA	MCF5234 256 MAPBGA	MCF5235 256 MAPBGA
$\overline{U1RTS}$	PUARTL6	$\overline{U2RTS}$	—	O	—	C8	B11	B11	B11
U1TXD	PUARTL5	CAN0TX	—	O	135	D9	A12	A12	A12
U1RXD	PUARTL4	CAN0RX	—	I	136	D8	A11	A11	A11
$\overline{U0CTS}$	PUARTL3	—	—	I	—	F3	G1	G1	G1
$\overline{U0RTS}$	PUARTL2	—	—	O	—	G3	H3	H3	H3
U0TXD	PUARTL1	—	—	O	14	F1	H2	H2	H2
U0RXD	PUARTL0	—	—	I	13	F2	G2	G2	G2
<b>DMA Timers</b>									
DT3IN	PTIMER7	$\overline{U2CTS}$	QSPI_CS2	I	—	H14	J15	J15	J15
DT3OUT	PTIMER6	$\overline{U2RTS}$	QSPI_CS3	O	—	G14	J16	J16	J16
DT2IN	PTIMER5	$\overline{DREQ2}$	DT2OUT	I	—	M9	P10	P10	P10
DT2OUT	PTIMER4	$\overline{DACK2}$	—	O	—	L9	R10	R10	R10
DT1IN	PTIMER3	$\overline{DREQ1}$	DT1OUT	I	—	L6	P7	P7	P7
DT1OUT	PTIMER2	$\overline{DACK1}$	—	O	—	M6	R7	R7	R7
DT0IN	PTIMER1	$\overline{DREQ0}$	—	I	—	E4	G4	G4	G4
DT0OUT	PTIMER0	$\overline{DACK0}$	—	O	—	F4	G3	G3	G3
<b>BDM/JTAG<sup>2</sup></b>									
DSCLK	—	TRST	—	I	70	N9	N11	N11	N11
PSTCLK	—	TCLK	—	O	68	P9	T10	T10	T10
$\overline{BKPT}$	—	TMS	—	I	71	P10	P11	P11	P11
DSI	—	TDI	—	I	73	M10	T11	T11	T11
DSO	—	TDO	—	O	72	N10	R11	R11	R11
JTAG_EN	—	—	—	I	78	K9	N13	N13	N13
DDATA[3:0]	—	—	—	O	—	M12, N12, P12, L11	N14, P14, T13, R13	N14, P14, T13, R13	N14, P14, T13, R13
PST[3:0]	—	—	—	O	77:74	M11, N11, P11, L10	T12, R12, P12, N12	T12, R12, P12, N12	T12, R12, P12, N12

**Table 2. MCF523x Signal Information and Muxing (continued)**

Signal Name	GPIO	Alternate 1	Alternate 2	Dir. <sup>1</sup>	MCF5232 160 QFP	MCF5232 196 MAPBGA	MCF5233 256 MAPBGA	MCF5234 256 MAPBGA	MCF5235 256 MAPBGA
<b>Test</b>									
TEST	—	—	—	I	18	F5	J4	J4	J4
PLL_TEST	—	—	—	I	—		R14	R14	R14
<b>Power Supplies</b>									
VDDPLL	—	—	—	I	87	M13	P15		
VSSPLL	—	—	—	I	84	L14	R15		
OVDD	—	—	—	I	1, 9, 17, 32, 41, 55, 62, 69, 81, 90, 95, 105, 114, 128, 132, 138, 146	E5, E7, E10, F7, F9, G6, G8, H7, H8, H9, J6, J8, J10, K5, K6, K8	E6:11, F5, F7:10, F12, G5, G6, G11, G12, H5, H6, H11, H12, J5, J6, J11, J12, K5, K6, K11, K12, L5, L7:10, L12, M6:M11		
VSS	—	—	—	I	8, 16, 25, 31, 40, 54, 61, 67, 80, 88, 94, 104, 113, 127, 131, 137, 145, 153, 160	A1, A14, E6, E9, F6, F8, F10, G7, G9, H6, J5, J7, J9, K7, P1, P14	A1, A16, E5, E12, F6, F11, F16, G7:10, H7: 10, J1, J7:10, K7:10, L6, L11, M5, M12, N16, T1, T6, T16		
VDD	—	—	—	I	15, 53, 103, 144	D6, F11, G4, L4	A8, G16, H1, T5		

NOTES:

- <sup>1</sup> Refers to pin's primary function. All pins which are configurable for GPIO have a pullup enabled in GPIO mode with the exception of PBUSCTL[7], PBUSCTL[4:0], PADDR, PBS, PSDRAM.
- <sup>2</sup> If JTAG\_EN is asserted, these pins default to Alternate 1 (JTAG) functionality. The GPIO module is not responsible for assigning these pins.

## 3 Modes of Operation

### 3.1 Chip Configuration Mode—Device Operating Options

- Chip operating mode:
  - Master mode
- Boot device/size:
  - External device boot
    - 32-bit
    - 16-bit (Default)

- 8-bit
- Output pad strength:
  - Partial drive strength (Default)
  - Full drive strength
- Clock mode:
  - Normal PLL with external crystal
  - Normal PLL with external clock
  - 1:1 PLL Mode
  - External oscillator mode (no PLL)
- Chip Select Configuration:
  - PADDR[7:5] configured as chip select(s) and/or address line(s)
    - PADDR[7:5] configured as A23-A21 (default)
    - PADDR configured as  $\overline{CS6}$ , PADDR[6:5] as A22-A21
    - PADDR[7:6] configured as  $\overline{CS}[6:5]$ , PADDR5 as A21
    - PADDR[7:5] configured as  $\overline{CS}[6:4]$

### 3.1.1 Chip Configuration Pins

Table 3. Configuration Pin Descriptions

Pin	Chip Configuration Function	Pin State/Meaning	Comments
$\overline{RCON}$	Chip configuration enable	1 Disabled 0 Enabled	Active low: if asserted, then all configuration pins must be driven appropriately for desired operation
D16	Select chip operating mode	1 Master 0 Reserved	
D20, D19	Select external boot device data port size	00,11 External (32-bit) 10 External (8-bit) 01 External (16-bit)	Value read defaults to 32-bit
D21	Select output pad drive strength	1 Full 0 Partial	
CLKMOD1, CLKMOD0	Select clock mode	00 External clock mode (no PLL) 01 1:1 PLL mode 10 Normal PLL with external clock reference 11 Normal PLL with crystal clock reference	VDDPLL must be supplied if a PLL mode is selected

**Table 3. Configuration Pin Descriptions (continued)**

Pin	Chip Configuration Function	Pin State/Meaning	Comments
D25, D24	Select chip select / address line	00 PADDR[7:5] configured as A23-A21 (default) 10 PADDR7 configured as $\overline{CS}6$ , PADDR[6:5] as A22-A21 01 PADDR[7:6] configured as $\overline{CS}[6:5]$ , PADDR5 as A21 11 PADDR[7:5] configured as $\overline{CS}[6:4]$	
JTAG_EN	Selects BDM or JTAG mode	0 BDM mode 1 JTAG mode	

## 3.2 Low Power Modes

The following features are available to support applications which require low power.

- Four modes of operation:
  - RUN
  - WAIT
  - DOZE
  - STOP
- Ability to shut down most peripherals independently.
- Ability to shut down the external CLKOUT pin.

There are four modes of operation: RUN, WAIT, DOZE, and STOP. The system enters a low power mode when the user programs the low power bits (LPMD) in the LPCR (Low Power Control Register) in the CIM before the CPU core executes a STOP instruction. This idles the CPU with no cycles active. The LPMD bits indicate to the system and clock controller to power down and stop the clocks appropriately. During STOP mode, the system clock is stopped low.

A wakeup event is required to exit a low power mode and return back to RUN mode. Wakeup events consist of any of the following conditions. See the following sections for more details.

1. Any type of reset.
2. Assertion of the  $\overline{BKPT}$  pin to request entry into Debug mode.
3. Debug request bit in the BDM control register to request entry into debug mode.
4. Any valid interrupt request.

### 3.2.1 RUN Mode

RUN mode is the normal system operating mode. Current consumption in this mode is related directly to the frequency chosen for the system clock.



### 3.2.2 WAIT Mode

WAIT mode is intended to be used to stop only the CPU core and memory clocks until a wakeup event is detected. In this mode, peripherals may be programmed to continue operating and can generate interrupts, which cause the CPU core to exit from WAIT mode.

### 3.2.3 DOZE Mode

DOZE mode affects the CPU core in the same manner as WAIT mode, but with a different code on the CIM LPMD bits, which are monitored by the peripherals. Each peripheral defines individual operational characteristics in DOZE mode. Peripherals which continue to run and have the capability of producing interrupts may cause the CPU to exit the DOZE mode and return to the RUN mode. Peripherals which are stopped will restart operation on exit from DOZE mode as defined for each peripheral.

### 3.2.4 STOP Mode

STOP mode affects the CPU core in the same manner as the WAIT and DOZE modes, but with a different code on the CCM LPMD bits. In this mode, all clocks to the system are stopped and the peripherals cease operation.

STOP mode must be entered in a controlled manner to ensure that any current operation is properly terminated. When exiting STOP mode, most peripherals retain their pre-stop status and resume operation.

### 3.2.5 Peripheral Shut Down

Most peripherals may be disabled by software in order to cease internal clock generation and remain in a static state. Each peripheral has its own specific disabling sequence (refer to each peripheral description for further details). A peripheral may be disabled at anytime and will remain disabled during any low power mode of operation.

## 4 Design Recommendations

### 4.1 Layout

- Use a 4-layer printed circuit board with the VDD and GND pins connected directly to the power and ground planes for the MCF523x.
- See application note AN1259 System Design and Layout Techniques for Noise Reduction in processor-Based Systems.
- Match the PC layout trace width and routing to match trace length to operating frequency and board impedance. Add termination (series or therein) to the traces to dampen reflections. Increase the PCB impedance (if possible) keeping the trace lengths balanced and short. Then do cross-talk analysis to separate traces with significant parallelism or are otherwise "noisy". Use 6 mils trace and separation. Clocks get extra separation and more precise balancing.

## 4.2 Power Supply

- 33  $\mu$ F, .1  $\mu$ F and .01  $\mu$ F across each power supply

## 4.3 Decoupling

- Place the decoupling caps as close to the pins as possible, but they can be outside the footprint of the package.
- .1  $\mu$ F and .01  $\mu$ F at each supply input

## 4.4 Buffering

- Use bus buffers on all data/address lines for all off-board accesses and for all on-board accesses when excessive loading is expected. See [Section 6, “Preliminary Electrical Characteristics.”](#)

## 4.5 Pull-up Recommendations

- Use external pull-up resistors on unused inputs. See pin table.

## 4.6 Clocking Recommendations

- Use a multi-layer board with a separate ground plane.
- Place the crystal and all other associated components as close to the EXTAL and XTAL (oscillator pins) as possible.
- Do not run a high frequency trace around crystal circuit.
- Ensure that the ground for the bypass capacitors is connected to a solid ground trace.
- Tie the ground trace to the ground pin nearest EXTAL and XTAL. This prevents large loop currents in the vicinity of the crystal.
- Tie the ground pin to the most solid ground in the system.
- Do not connect the trace that connects the oscillator and the ground plane to any other circuit element. This tends to make the oscillator unstable.
- Tie XTAL to ground when an external oscillator is clocking the device.

## 4.7 Interface Recommendations

### 4.7.1 SDRAM Controller

#### 4.7.1.1 SDRAM Controller Signals in Synchronous Mode

[Table 4](#) shows the behavior of SDRAM signals in synchronous mode.

**Table 4. Synchronous DRAM Signal Connections**

Signal	Description
$\overline{\text{SD\_SRAS}}$	Synchronous row address strobe. Indicates a valid SDRAM row address is present and can be latched by the SDRAM. $\overline{\text{SD\_SRAS}}$ should be connected to the corresponding SDRAM $\overline{\text{SD\_SRAS}}$ . Do not confuse $\overline{\text{SD\_SRAS}}$ with the DRAM controller's $\overline{\text{SD\_CS}}[1:0]$ , which should not be interfaced to the SDRAM $\overline{\text{SD\_SRAS}}$ signals.
$\overline{\text{SD\_SCAS}}$	Synchronous column address strobe. Indicates a valid column address is present and can be latched by the SDRAM. $\overline{\text{SD\_SCAS}}$ should be connected to the corresponding signal labeled $\overline{\text{SD\_SCAS}}$ on the SDRAM.
$\overline{\text{DRAMW}}$	DRAM read/write. Asserted for write operations and negated for read operations.
$\overline{\text{SD\_CS}}[1:0]$	Row address strobe. Select each memory block of SDRAMs connected to the MCF523x. One $\overline{\text{SD\_CS}}$ signal selects one SDRAM block and connects to the corresponding $\overline{\text{CS}}$ signals.
$\overline{\text{SD\_CKE}}$	Synchronous DRAM clock enable. Connected directly to the CKE (clock enable) signal of SDRAMs. Enables and disables the clock internal to SDRAM. When CKE is low, memory can enter a power-down mode where operations are suspended or they can enter self-refresh mode. $\overline{\text{SD\_CKE}}$ functionality is controlled by DCR[COC]. For designs using external multiplexing, setting COC allows $\overline{\text{SD\_CKE}}$ to provide command-bit functionality.
$\overline{\text{BS}}[3:0]$	Column address strobe. For synchronous operation, $\overline{\text{BS}}[3:0]$ function as byte enables to the SDRAMs. They connect to the DQM signals (or mask qualifiers) of the SDRAMs.
CLKOUT	Bus clock output. Connects to the CLK input of SDRAMs.

#### 4.7.1.2 Address Multiplexing

Table 5 shows the generic address multiplexing scheme for SDRAM configurations. All possible address connection configurations can be derived from this table.

**Table 5. Generic Address Multiplexing Scheme**

Address Pin	Row Address	Column Address	Notes Related to Port Sizes
17	17	0	8-bit port only
16	16	1	8- and 16-bit ports only
15	15	2	
14	14	3	
13	13	4	
12	12	5	
11	11	6	
10	10	7	
9	9	8	
17	17	16	32-bit port only
18	18	17	16-bit port only or 32-bit port with only 8 column address lines
19	19	18	16-bit port only when at least 9 column address lines are used
20	20	19	

**Table 5. Generic Address Multiplexing Scheme (continued)**

Address Pin	Row Address	Column Address	Notes Related to Port Sizes
21	21	20	
22	22	21	
23	23	22	
24	24	23	
25	25	24	

The following tables provide a more comprehensive, step-by-step way to determine the correct address line connections for interfacing the MCF523x to SDRAM. To use the tables, find the one that corresponds to the number of column address lines on the SDRAM and to the port size as seen by the MCF523x, which is not necessarily the SDRAM port size. For example, if two 1M x 16-bit SDRAMs together form a 2M x 32-bit memory, the port size is 32 bits. Most SDRAMs likely have fewer address lines than are shown in the tables, so follow only the connections shown until all SDRAM address lines are connected.

**Table 6. MCF523x to SDRAM Interface (8-Bit Port, 9-Column Address Lines)**

MCF523x Pins	A17	A16	A15	A14	A13	A12	A11	A10	A9	A18	A19	A20	A21	A22	A23	A24	A25	A26	A27	A28	A29	A30	A31
Row	17	16	15	14	13	12	11	10	9	18	19	20	21	22	23	24	25	26	27	28	29	30	31
Column	0	1	2	3	4	5	6	7	8														
SDRAM Pins	A0	A1	A2	A3	A4	A5	A6	A7	A8	A9	A10	A11	A12	A13	A14	A15	A16	A17	A18	A19	A20	A21	A22

**Table 7. MCF523x to SDRAM Interface (8-Bit Port, 10-Column Address Lines)**

MCF523x Pins	A17	A16	A15	A14	A13	A12	A11	A10	A9	A19	A20	A21	A22	A23	A24	A25	A26	A27	A28	A29	A30	A31
Row	17	16	15	14	13	12	11	10	9	19	20	21	22	23	24	25	26	27	28	29	30	31
Column	0	1	2	3	4	5	6	7	8	18												
SDRAM Pins	A0	A1	A2	A3	A4	A5	A6	A7	A8	A9	A10	A11	A12	A13	A14	A15	A16	A17	A18	A19	A20	A21

**Table 8. MCF523x to SDRAM Interface (8-Bit Port, 11-Column Address Lines)**

MCF523x Pins	A17	A16	A15	A14	A13	A12	A11	A10	A9	A19	A21	A22	A23	A24	A25	A26	A27	A28	A29	A30	A31
Row	17	16	15	14	13	12	11	10	9	19	21	22	23	24	25	26	27	28	29	30	31
Column	0	1	2	3	4	5	6	7	8	18	20										
SDRAM Pins	A0	A1	A2	A3	A4	A5	A6	A7	A8	A9	A10	A11	A12	A13	A14	A15	A16	A17	A18	A19	A20

**Table 9. MCF523x to SDRAM Interface (8-Bit Port, 12-Column Address Lines)**

MCF523x Pins	A17	A16	A15	A14	A13	A12	A11	A10	A9	A19	A21	A23	A24	A25	A26	A27	A28	A29	A30	A31
Row	17	16	15	14	13	12	11	10	9	19	21	23	24	25	26	27	28	29	30	31
Column	0	1	2	3	4	5	6	7	8	18	20	22								
SDRAM Pins	A0	A1	A2	A3	A4	A5	A6	A7	A8	A9	A10	A11	A12	A13	A14	A15	A16	A17	A18	A19

**Table 10. MCF523x to SDRAM Interface (8-Bit Port, 13-Column Address Lines)**

MCF523x Pins	A17	A16	A15	A14	A13	A12	A11	A10	A9	A19	A21	A23	A25	A26	A27	A28	A29	A30	A31
Row	17	16	15	14	13	12	11	10	9	19	21	23	25	26	27	28	29	30	31
Column	0	1	2	3	4	5	6	7	8	18	20	22	24						
SDRAM Pins	A0	A1	A2	A3	A4	A5	A6	A7	A8	A9	A10	A11	A12	A13	A14	A15	A16	A17	A18

**Table 11. MCF523x to SDRAM Interface (16-Bit Port, 8-Column Address Lines)**

MCF523x Pins	A16	A15	A14	A13	A12	A11	A10	A9	A17	A18	A19	A20	A21	A22	A23	A24	A25	A26	A27	A28	A29	A30	A31
Row	16	15	14	13	12	11	10	9	17	18	19	20	21	22	23	24	25	26	27	28	29	30	31
Column	1	2	3	4	5	6	7	8															
SDRAM Pins	A0	A1	A2	A3	A4	A5	A6	A7	A8	A9	A10	A11	A12	A13	A14	A15	A16	A17	A18	A19	A20	A21	A22

**Table 12. MCF523x to SDRAM Interface (16-Bit Port, 9-Column Address Lines)**

MCF523x Pins	A16	A15	A14	A13	A12	A11	A10	A9	A18	A19	A20	A21	A22	A23	A24	A25	A26	A27	A28	A29	A30	A31
Row	16	15	14	13	12	11	10	9	18	19	20	21	22	23	24	25	26	27	28	29	30	31
Column	1	2	3	4	5	6	7	8	17													
SDRAM Pins	A0	A1	A2	A3	A4	A5	A6	A7	A8	A9	A10	A11	A12	A13	A14	A15	A16	A17	A18	A19	A20	A21

**Table 13. MCF523x to SDRAM Interface (16-Bit Port, 10-Column Address Lines)**

MCF523x Pins	A16	A15	A14	A13	A12	A11	A10	A9	A18	A20	A21	A22	A23	A24	A25	A26	A27	A28	A29	A30	A31
Row	16	15	14	13	12	11	10	9	18	20	21	22	23	24	25	26	27	28	29	30	31
Column	1	2	3	4	5	6	7	8	17	19											
SDRAM Pins	A0	A1	A2	A3	A4	A5	A6	A7	A8	A9	A10	A11	A12	A13	A14	A15	A16	A17	A18	A19	A20

## Design Recommendations

**Table 14. MCF523x to SDRAM Interface (16-Bit Port, 11-Column Address Lines)**

MCF523x Pins	A16	A15	A14	A13	A12	A11	A10	A9	A18	A20	A22	A23	A24	A25	A26	A27	A28	A29	A30	A31
Row	16	15	14	13	12	11	10	9	18	20	22	23	24	25	26	27	28	29	30	31
Column	1	2	3	4	5	6	7	8	17	19	21									
SDRAM Pins	A0	A1	A2	A3	A4	A5	A6	A7	A8	A9	A10	A11	A12	A13	A14	A15	A16	A17	A18	A19

**Table 15. MCF523x to SDRAM Interface (16-Bit Port, 12-Column Address Lines)**

MCF523x Pins	A16	A15	A14	A13	A12	A11	A10	A9	A18	A20	A22	A24	A25	A26	A27	A28	A29	A30	A31	
Row	16	15	14	13	12	11	10	9	18	20	22	24	25	26	27	28	29	30	31	
Column	1	2	3	4	5	6	7	8	17	19	21	23								
SDRAM Pins	A0	A1	A2	A3	A4	A5	A6	A7	A8	A9	A10	A11	A12	A13	A14	A15	A16	A17	A18	

**Table 16. MCF523x to SDRAM Interface (16-Bit Port, 13-Column-Address Lines)**

MCF523x Pins	A16	A15	A14	A13	A12	A11	A10	A9	A18	A20	A22	A24	A26	A27	A28	A29	A30	A31	
Row	16	15	14	13	12	11	10	9	18	20	22	24	26	27	28	29	30	31	
Column	1	2	3	4	5	6	7	8	17	19	21	23	25						
SDRAM Pins	A0	A1	A2	A3	A4	A5	A6	A7	A8	A9	A10	A11	A12	A13	A14	A15	A16	A17	

**Table 17. MCF523x to SDRAM Interface (32-Bit Port, 8-Column Address Lines)**

MCF523x Pins	A15	A14	A13	A12	A11	A10	A9	A17	A18	A19	A20	A21	A22	A23	A24	A25	A26	A27	A28	A29	A30	A31
Row	15	14	13	12	11	10	9	17	18	19	20	21	22	23	24	25	26	27	28	29	30	31
Column	2	3	4	5	6	7	8	16														
SDRAM Pins	A0	A1	A2	A3	A4	A5	A6	A7	A8	A9	A10	A11	A12	A13	A14	A15	A16	A17	A18	A19	A20	A21

**Table 18. MCF523x to SDRAM Interface (32-Bit Port, 9-Column Address Lines)**

MCF523x Pins	A15	A14	A13	A12	A11	A10	A9	A17	A19	A20	A21	A22	A23	A24	A25	A26	A27	A28	A29	A30	A31	
Row	15	14	13	12	11	10	9	17	19	20	21	22	23	24	25	26	27	28	29	30	31	
Column	2	3	4	5	6	7	8	16	18													
SDRAM Pins	A0	A1	A2	A3	A4	A5	A6	A7	A8	A9	A10	A11	A12	A13	A14	A15	A16	A17	A18	A19	A20	

**Table 19. MCF523x to SDRAM Interface (32-Bit Port, 10-Column Address Lines)**

MCF523x Pins	A15	A14	A13	A12	A11	A10	A9	A17	A19	A21	A22	A23	A24	A25	A26	A27	A28	A29	A30	A31
Row	15	14	13	12	11	10	9	17	19	21	22	23	24	25	26	27	28	29	30	31
Column	2	3	4	5	6	7	8	16	18	20										
SDRAM Pins	A0	A1	A2	A3	A4	A5	A6	A7	A8	A9	A10	A11	A12	A13	A14	A15	A16	A17	A18	A19

**Table 20. MCF523x to SDRAM Interface (32-Bit Port, 11-Column Address Lines)**

MCF523x Pins	A15	A14	A13	A12	A11	A10	A9	A17	A19	A21	A23	A24	A25	A26	A27	A28	A29	A30	A31	
Row	15	14	13	12	11	10	9	17	19	21	23	24	25	26	27	28	29	30	31	
Column	2	3	4	5	6	7	8	16	18	20	22									
SDRAM Pins	A0	A1	A2	A3	A4	A5	A6	A7	A8	A9	A10	A11	A12	A13	A14	A15	A16	A17	A18	

**Table 21. MCF523x to SDRAM Interface (32-Bit Port, 12-Column Address Lines)**

MCF523x Pins	A15	A14	A13	A12	A11	A10	A9	A17	A19	A21	A23	A25	A26	A27	A28	A29	A30	A31		
Row	15	14	13	12	11	10	9	17	19	21	23	25	26	27	28	29	30	31		
Column	2	3	4	5	6	7	8	16	18	20	22	24								
SDRAM Pins	A0	A1	A2	A3	A4	A5	A6	A7	A8	A9	A10	A11	A12	A13	A14	A15	A16	A17		

### 4.7.1.3 SDRAM Interfacing Example

The tables in the previous section can be used to configure the interface in the following example. To interface one 2M × 32-bit × 4 bank SDRAM component (8 columns) to the MCF523x, the connections would be as shown in [Table 22](#).

**Table 22. SDRAM Hardware Connections**

SDRAM Pins	A0	A1	A2	A3	A4	A5	A6	A7	A8	A9	A10 = CMD	BA0	BA1
MCF523x Pins	A15	A14	A13	A12	A11	A10	A9	A17	A18	A19	A20	A21	A22

## 4.7.2 Ethernet PHY Transceiver Connection

The FEC supports both an MII interface for 10/100 Mbps Ethernet and a seven-wire serial interface for 10 Mbps Ethernet. The interface mode is selected by R\_CNTRL[MII\_MODE]. In MII mode, the 802.3 standard defines and the FEC module supports 18 signals. These are shown in [Table 23](#).

**Table 23. MII Mode**

Signal Description	MCF523x Pin
Transmit clock	ETXCLK
Transmit enable	ETXEN
Transmit data	ETXD[3:0]
Transmit error	ETXER
Collision	ECOL
Carrier sense	ECRS
Receive clock	ERXCLK
Receive enable	ERXDV
Receive data	ERXD[3:0]
Receive error	ERXER
Management channel clock	EMDC
Management channel serial data	EMDIO

The serial mode interface operates in what is generally referred to as AMD mode. The MCF523x configuration for seven-wire serial mode connections to the external transceiver are shown in [Table 24](#).

**Table 24. Seven-Wire Mode Configuration**

Signal Description	MCF523x Pin
Transmit clock	ETXCLK
Transmit enable	ETXEN
Transmit data	ETXD[0]
Collision	ECOL
Receive clock	ERXCLK
Receive enable	ERXDV
Receive data	ERXD[0]
Unused, configure as PB14	ERXER
Unused input, tie to ground	ECRS
Unused, configure as PB[13:11]	ERXD[3:1]
Unused output, ignore	ETXER
Unused, configure as PB[10:8]	ETXD[3:1]
Unused, configure as PB15	EMDC
Input after reset, connect to ground	EMDIO

Refer to the M523xEVB evaluation board user's manual for an example of how to connect an external PHY. Schematics for this board are accessible at the MCF5235 site by navigating to: <http://www.freescale.com>.



### 4.7.2.1 FlexCAN

The FlexCAN module interface to the CAN bus is composed of 2 pins: CANTX and CANRX, which are the serial transmitted data and the serial received data. The use of an external CAN transceiver to interface to the CAN bus is generally required. The transceiver is capable of driving the large current needed for the CAN bus and has current protection, against a defective CAN bus or defective stations.

### 4.7.3 BDM

Use the BDM interface as shown in the M523xEVB evaluation board user's manual. The schematics for this board are accessible at the MCF523x site by navigating from: <http://www.freescale.com> following the 32-bit Embedded Processors, 68K/ColdFire, MCF5xxx, MCF523x and M523xEVB links.

## 5 Mechanicals/Pinouts and Part Numbers

This section contains drawings showing the pinout and the packaging and mechanical characteristics of the MCF523x devices. See [Table 2](#) for a list the signal names and pin locations for each device.

## 5.1 Pinout—196 MAPBGA

Figure 2 shows a pinout of the MCF5232CVMxxx package.

	1	2	3	4	5	6	7	8	9	10	11	12	13	14	
A	VSS	TPUCH6	TPUCH3	TPUCH2	QSPI_DOUT	QSPI_CS0	U2RXD	U2TXD	$\overline{\text{CS}}_3$	$\overline{\text{CS}}_6$	$\overline{\text{CS}}_4$	A20	A17	VSS	A
B	TPUCH8	TPUCH7	TPUCH4	TPUCH0	QSPI_DIN	$\overline{\text{BS}}_3$	QSPI_CS1	$\overline{\text{U1CTS}}$	$\overline{\text{CS}}_7$	$\overline{\text{CS}}_1$	A23	A19	A16	A15	B
C	TPUCH10	TPUCH9	TPUCH5	TPUCH1	QSPI_CLK	$\overline{\text{BS}}_2$	$\overline{\text{BS}}_0$	$\overline{\text{U1RTS}}$	$\overline{\text{CS}}_2$	$\overline{\text{CS}}_5$	A22	A18	A14	A13	C
D	TPUCH13	TPUCH12	TPUCH11	NC	NC	VDD	$\overline{\text{BS}}_1$	U1RXD/ CAN0RX	U1TXD/ CAN0TX	$\overline{\text{CS}}_0$	A21	A12	A11	A10	D
E	TPUCH14	TPUCH15	TCRCLK	DT0IN	OVDD	VSS	OVDD	SD_CKE	VSS	OVDD	A9	A8	A7	A6	E
F	U0TXD	U0RXD	$\overline{\text{U0CTS}}$	DT0OUT	TEST	VSS	OVDD	VSS	OVDD	VSS	VDD	A5	A4	A3	F
G	D31	D30	$\overline{\text{U0RTS}}$	VDD	CLKMOD1	OVDD	VSS	OVDD	VSS	LTPU ODIS	A2	A1	A0	DT3OUT	G
H	D29	D28	D27	D26	CLKMOD0	VSS	OVDD	OVDD	OVDD	UTPU ODIS	$\overline{\text{TA}}$	$\overline{\text{TIP}}$	$\overline{\text{TS}}$	DT3IN	H
J	D25	D24	D23	D22	VSS	OVDD	VSS	OVDD	VSS	OVDD	I2C_SCL	I2C_SDA	$\overline{\text{RW}}$	$\overline{\text{TEA}}$	J
K	D21	D20	D19	D18	OVDD	OVDD	VSS	OVDD	JTAG_EN	$\overline{\text{RCON}}$	$\overline{\text{SD_SRAS}}$	$\overline{\text{SD_SCAS}}$	$\overline{\text{SD_WE}}$	CLKOUT	K
L	D17	D16	D10	VDD	D3	DT1IN	$\overline{\text{IRQ}}_5$	$\overline{\text{IRQ}}_1$	DT2OUT	PST0	DDATA0	$\overline{\text{SD_CS}}_1$	$\overline{\text{SD_CS}}_0$	VSSPLL	L
M	D15	D13	D9	D6	D2	DT1OUT	$\overline{\text{IRQ}}_6$	$\overline{\text{IRQ}}_2$	DT2IN	TDI/DSI	PST3	DDATA3	VDDPLL	EXTAL	M
N	D14	D12	D8	D5	D1	$\overline{\text{OE}}$	$\overline{\text{IRQ}}_7$	$\overline{\text{IRQ}}_3$	$\overline{\text{TRST}}/$ DSCLK	TDO/DSO	PST2	DDATA2	$\overline{\text{RESET}}$	XTAL	N
P	VSS	D11	D7	D4	D0	TSIZ1	TSIZ0	$\overline{\text{IRQ}}_4$	TCLK/ PSTCLK	TMS/ BKPT	PST1	DDATA1	$\overline{\text{RSTOUT}}$	VSS	P
	1	2	3	4	5	6	7	8	9	10	11	12	13	14	

Figure 2. MCF5232CVMxxx Pinout (196 MAPBGA)

## 5.2 Package Dimensions—196 MAPBGA

Figure 3 shows MCF5232CVMxxx package dimensions.

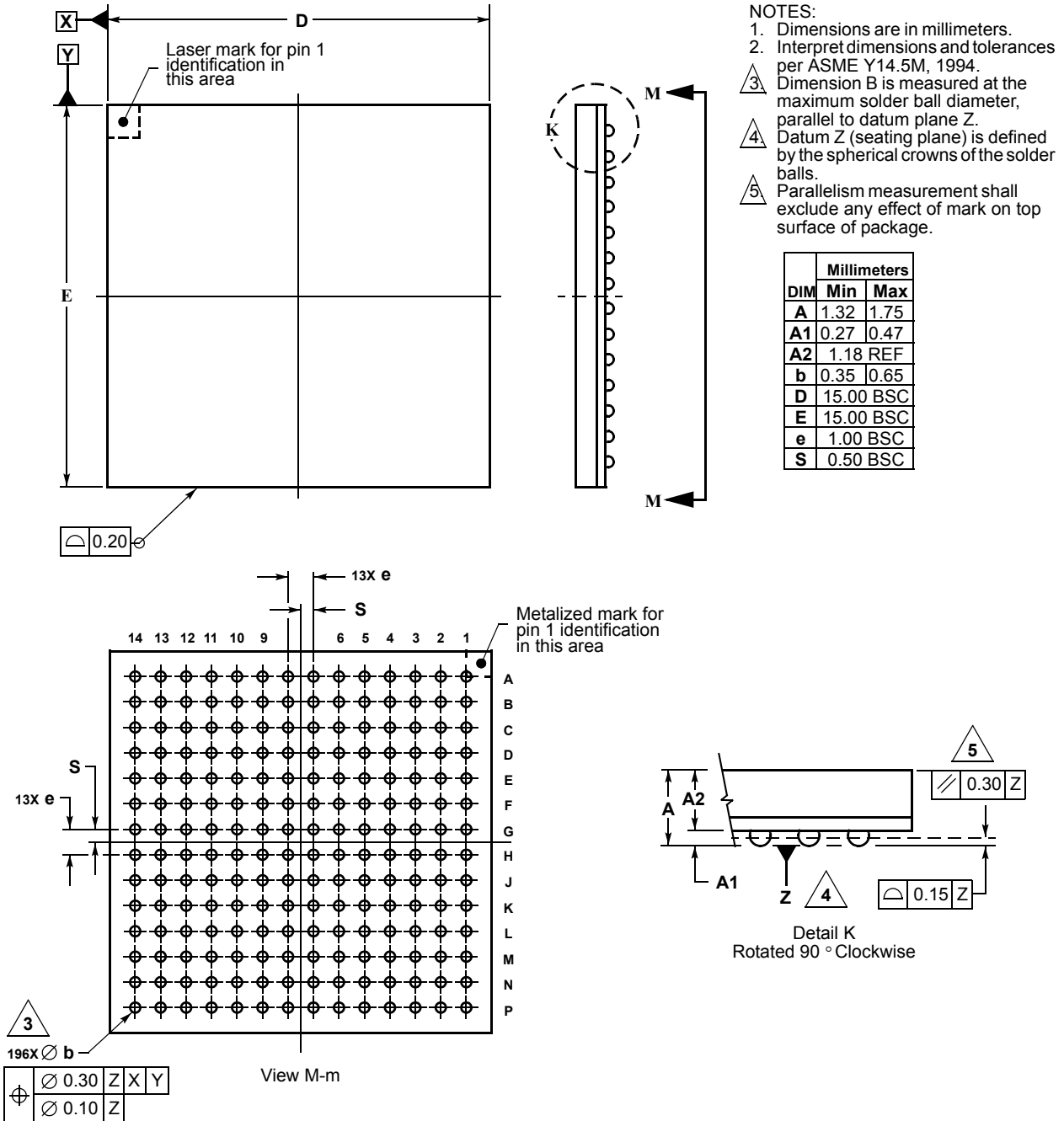

Figure 3. 196 MAPBGA Package Dimensions (Case No. 1128A-01)

## 5.2.1 Pinout—256 MAPBGA

Figure 4 through Figure 6 show pinouts of the MCF5233CVMxxx, MCF5234CVMxxx, and MCF5235CVMxxx packages.

	1	2	3	4	5	6	7	8	9	10	11	12	13	14	15	16	
A	VSS	TPUCH6	TPUCH4	TPUCH2	TPUCH17	TPUCH1	TPUCH0	VDD	$\overline{BS1}$	$\overline{BS0}$	U1RXD/ CAN0RX	U1TXD/ CAN0TX	$\overline{CS6}$	$\overline{CS4}$	A21	VSS	A
B	TPUCH8	TPUCH7	TPUCH5	TPUCH3	TPUCH18	TPUCH19	TPUCH16	QSPL_ CLK	$\overline{BS2}$	QSPL_ CS1	$\overline{U1RTS}$	$\overline{CS3}$	$\overline{CS1}$	A23	A20	A19	B
C	TPUCH10	TPUCH9	TPUCH25	TPUCH24	TPUCH22	TPUCH20	I2C_SDA/ U2RXD	QSPL_ DIN	$\overline{BS3}$	SD_CKE	$\overline{U1CTS}$	$\overline{CS7}$	$\overline{CS5}$	A22	A18	A17	C
D	TPUCH12	TPUCH11	TPUCH27	TPUCH26	TPUCH23	TPUCH21	I2C_SCL/ U2TXD	QSPL_ DOUT	QSPL_ CS0	U2RXD/ CAN1RX	U2TXD/ CAN1TX	$\overline{CS2}$	$\overline{CS0}$	A14	A15	A16	D
E	TPUCH14	TPUCH13	TPUCH29	TPUCH28	VSS	OVDD	OVDD	OVDD	OVDD	OVDD	OVDD	VSS	A10	A11	A12	A13	E
F	TCRCLK	TPUCH15	TPUCH31	TPUCH30	OVDD	VSS	OVDD	OVDD	OVDD	OVDD	VSS	OVDD	A7	A8	A9	VSS	F
G	$\overline{U0CTS}$	U0RXD	DT0OUT	DT0IN	OVDD	OVDD	VSS	VSS	VSS	VSS	OVDD	OVDD	A4	A5	A6	VDD	G
H	VDD	U0TXD	$\overline{U0RTS}$	NC	OVDD	OVDD	VSS	VSS	VSS	VSS	OVDD	OVDD	A0	A1	A2	A3	H
J	VSS	CLK MOD0	CLK MOD1	TEST	OVDD	OVDD	VSS	VSS	VSS	VSS	OVDD	OVDD	UTPU ODIS	LTPU ODIS	DT3IN	DT3OUT	J
K	D28	D29	D30	D31	OVDD	OVDD	VSS	VSS	VSS	VSS	OVDD	OVDD	$\overline{TEA}$	$\overline{TA}$	$\overline{TIP}$	$\overline{TS}$	K
L	D24	D25	D26	D27	OVDD	VSS	OVDD	OVDD	OVDD	OVDD	VSS	OVDD	$\overline{SD\_WE}$	I2C_SCL/ CAN0TX	I2C_SDA/ CAN0RX	R/W	L
M	D21	D22	D23	NC	VSS	OVDD	OVDD	OVDD	OVDD	OVDD	OVDD	VSS	$\overline{SD\_CS0}$	$\overline{SD\_SRAS}$	$\overline{SD\_SCAS}$	CLKOUT	M
N	D19	D20	D13	D9	NC	D3	D0	TSIZ1	$\overline{IRQ5}$	$\overline{IRQ1}$	$\overline{TRST}/$ DSCLK	PST0	JTAG_ EN	DDATA3	$\overline{SD\_CS1}$	VSS	N
P	D17	D18	D12	D8	D5	D2	DT1IN	TSIZ0	$\overline{IRQ4}$	DT2IN	TMS/ BKPT	PST1	$\overline{RCON}$	DDATA2	VDDPLL	EXTAL	P
R	D16	D15	D11	D7	D4	D1	DT1OUT	$\overline{IRQ7}$	$\overline{IRQ3}$	DT2OUT	TDO/ DSO	PST2	DDATA0	PLL_ TEST	VSSPLL	XTAL	R
T	VSS	D14	D10	D6	VDD	VSS	$\overline{OE}$	$\overline{IRQ6}$	$\overline{IRQ2}$	TCLK/ PSTCLK	TDI/DSI	PST3	DDATA1	$\overline{RSTOUT}$	$\overline{RESET}$	VSS	T
	1	2	3	4	5	6	7	8	9	10	11	12	13	14	15	16	

Figure 4. MCF5233CVMxxx Pinout (256 MAPBGA)

	1	2	3	4	5	6	7	8	9	10	11	12	13	14	15	16	
A	VSS	TPUCH6	TPUCH4	TPUCH2	ETXD1	TPUCH1	TPUCH0	VDD	BS1	BS0	U1RXD/ CAN0RX	U1TXD/ CAN0TX	CS6	CS4	A21	VSS	A
B	TPUCH8	TPUCH7	TPUCH5	TPUCH3	ETXD2	ETXD3	ETXD0	QSPI_ CLK	BS2	QSPI_ CS1	U1RTS	CS3	CS1	A23	A20	A19	B
C	TPUCH10	TPUCH9	ERXD1	ERXD0	ETXCLK	ETXER	EMDIO	QSPI_ DIN	BS3	SD_CKE	U1CTS	CS7	CS5	A22	A18	A17	C
D	TPUCH12	TPUCH11	ERXD3	ERXD2	ERXER	ETXEN	EMDC	QSPI_ DOUT	QSPI_ CS0	U2RXD	U2TXD	CS2	CS0	A14	A15	A16	D
E	TPUCH14	TPUCH13	ERXCLK	ERXDV	VSS	OVDD	OVDD	OVDD	OVDD	OVDD	OVDD	VSS	A10	A11	A12	A13	E
F	TCRCLK	TPUCH15	ECOL	ECRS	OVDD	VSS	OVDD	OVDD	OVDD	OVDD	VSS	OVDD	A7	A8	A9	VSS	F
G	U0CTS	U0RXD	DT0OUT	DT0IN	OVDD	OVDD	VSS	VSS	VSS	VSS	OVDD	OVDD	A4	A5	A6	VDD	G
H	VDD	U0TXD	U0RTS	NC	OVDD	OVDD	VSS	VSS	VSS	VSS	OVDD	OVDD	A0	A1	A2	A3	H
J	VSS	CLK MOD0	CLK MOD1	TEST	OVDD	OVDD	VSS	VSS	VSS	VSS	OVDD	OVDD	UTPU ODIS	LTPU ODIS	DT3IN	DT3OUT	J
K	D28	D29	D30	D31	OVDD	OVDD	VSS	VSS	VSS	VSS	OVDD	OVDD	TEA	TA	TIP	TS	K
L	D24	D25	D26	D27	OVDD	VSS	OVDD	OVDD	OVDD	OVDD	VSS	OVDD	SD_WE	I2C_SCL/ CAN0TX	I2C_SDA/ CAN0RX	R/W	L
M	D21	D22	D23	NC	VSS	OVDD	OVDD	OVDD	OVDD	OVDD	OVDD	VSS	SD_CS0	SD_ SRAS	SD_ SCAS	CLKOUT	M
N	D19	D20	D13	D9	NC	D3	D0	TSIZ1	IRQ5	IRQ1	TRST/ DSCLK	PST0	JTAG_ EN	DDATA3	SD_CS1	VSS	N
P	D17	D18	D12	D8	D5	D2	DT1IN	TSIZ0	IRQ4	DT2IN	TMS/ BKPT	PST1	RCON	DDATA2	VDDPLL	EXTAL	P
R	D16	D15	D11	D7	D4	D1	DT1OUT	IRQ7	IRQ3	DT2OUT	TDO/ DSO	PST2	DDATA0	PLL_ TEST	VSSPLL	XTAL	R
T	VSS	D14	D10	D6	VDD	VSS	OE	IRQ6	IRQ2	TCLK/ PSTCLK	TDI/DSI	PST3	DDATA1	RST OUT	RESET	VSS	T
	1	2	3	4	5	6	7	8	9	10	11	12	13	14	15	16	

Figure 5. MCF5234CVMxxx Pinout (256 MAPBGA)

Mechanicals/Pinouts and Part Numbers

	1	2	3	4	5	6	7	8	9	10	11	12	13	14	15	16	
A	VSS	TPUCH6	TPUCH4	TPUCH2	TPUCH17/ ETXD1	TPUCH1	TPUCH0	VDD	$\overline{BS1}$	$\overline{BS0}$	U1RXD/ CAN0RX	U1TXD/ CAN0TX	$\overline{CS6}$	$\overline{CS4}$	A21	VSS	A
B	TPUCH8	TPUCH7	TPUCH5	TPUCH3	TPUCH18/ ETXD2	TPUCH19/ ETXD3	TPUCH16/ ETXD0	QSPI_ CLK	$\overline{BS2}$	QSPI_ CS1	$\overline{U1RTS}$	$\overline{CS3}$	$\overline{CS1}$	A23	A20	A19	B
C	TPUCH10	TPUCH9	TPUCH25/ ERXD1	TPUCH24/ ERXD0	TPUCH22/ ETXCLK	TPUCH20/ ETXER	I2C_SDA/ U2RXD/ EMDIO	QSPI_ DIN	$\overline{BS3}$	SD_CKE	$\overline{U1CTS}$	$\overline{CS7}$	$\overline{CS5}$	A22	A18	A17	C
D	TPUCH12	TPUCH11	TPUCH27/ ERXD3	TPUCH26/ ERXD2	TPUCH23/ ETXER	TPUCH21/ ETXEN	I2C_SCL/ U2TXD/ EMDC	QSPI_ DOUT	QSPI_ CS0	U2RXD/ CAN1RX	U2TXD/ CAN1TX	$\overline{CS2}$	$\overline{CS0}$	A14	A15	A16	D
E	TPUCH14	TPUCH13	TPUCH29/ ERXCLK	TPUCH2/ ERXDV	VSS	OVDD	OVDD	OVDD	OVDD	OVDD	OVDD	VSS	A10	A11	A12	A13	E
F	TCRCLK	TPUCH15	TPUCH31/ ECOL	TPUCH30/ ECSR	OVDD	VSS	OVDD	OVDD	OVDD	OVDD	VSS	OVDD	A7	A8	A9	VSS	F
G	$\overline{U0CTS}$	U0RXD	DT0OUT	DT0IN	OVDD	OVDD	VSS	VSS	VSS	VSS	OVDD	OVDD	A4	A5	A6	VDD	G
H	VDD	U0TXD	$\overline{U0RTS}$	NC	OVDD	OVDD	VSS	VSS	VSS	VSS	OVDD	OVDD	A0	A1	A2	A3	H
J	VSS	CLK MOD0	CLK MOD1	TEST	OVDD	OVDD	VSS	VSS	VSS	VSS	OVDD	OVDD	UTPU ODIS	LTPU ODIS	DT3IN	DT3OUT	J
K	D28	D29	D30	D31	OVDD	OVDD	VSS	VSS	VSS	VSS	OVDD	OVDD	$\overline{TEA}$	$\overline{TA}$	$\overline{TIP}$	$\overline{TS}$	K
L	D24	D25	D26	D27	OVDD	VSS	OVDD	OVDD	OVDD	OVDD	VSS	OVDD	$\overline{SD\_WE}$	I2C_SCL/ CAN0TX	I2C_SDA/ CAN0RX	$\overline{R/W}$	L
M	D21	D22	D23	eTPU/ EthENB	VSS	OVDD	OVDD	OVDD	OVDD	OVDD	OVDD	VSS	$\overline{SD\_CS0}$	$\overline{SD}$ SRAS	$\overline{SD}$ SCAS	CLKOUT	M
N	D19	D20	D13	D9	NC	D3	D0	TSIZ1	$\overline{IRQ5}$	$\overline{IRQ1}$	$\overline{TRST}$ / DSCLK	PST0	JTAG_ EN	DDATA3	$\overline{SD\_CS1}$	VSS	N
P	D17	D18	D12	D8	D5	D2	DT1IN	TSIZ0	$\overline{IRQ4}$	DT2IN	TMS/ BKPT	PST1	$\overline{RCON}$	DDATA2	VDDPLL	EXTAL	P
R	D16	D15	D11	D7	D4	D1	DT1OUT	$\overline{IRQ7}$	$\overline{IRQ3}$	DT2OUT	TDO/ DSO	PST2	DDATA0	PLL_ TEST	VSSPLL	XTAL	R
T	VSS	D14	D10	D6	VDD	VSS	$\overline{OE}$	$\overline{IRQ6}$	$\overline{IRQ2}$	TCLK/ PSTCLK	TDI/DSI	PST3	DDATA1	$\overline{RSTOUT}$	$\overline{RESET}$	VSS	T
	1	2	3	4	5	6	7	8	9	10	11	12	13	14	15	16	

Figure 6. MCF5235CVMxxx Pinout (256 MAPBGA)

## 5.2.2 Package Dimensions—256 MAPBGA

Figure 7 shows MCF5235CVMxxx, MCF5234CVMxxx, and MCF5233CVMxx package dimensions.

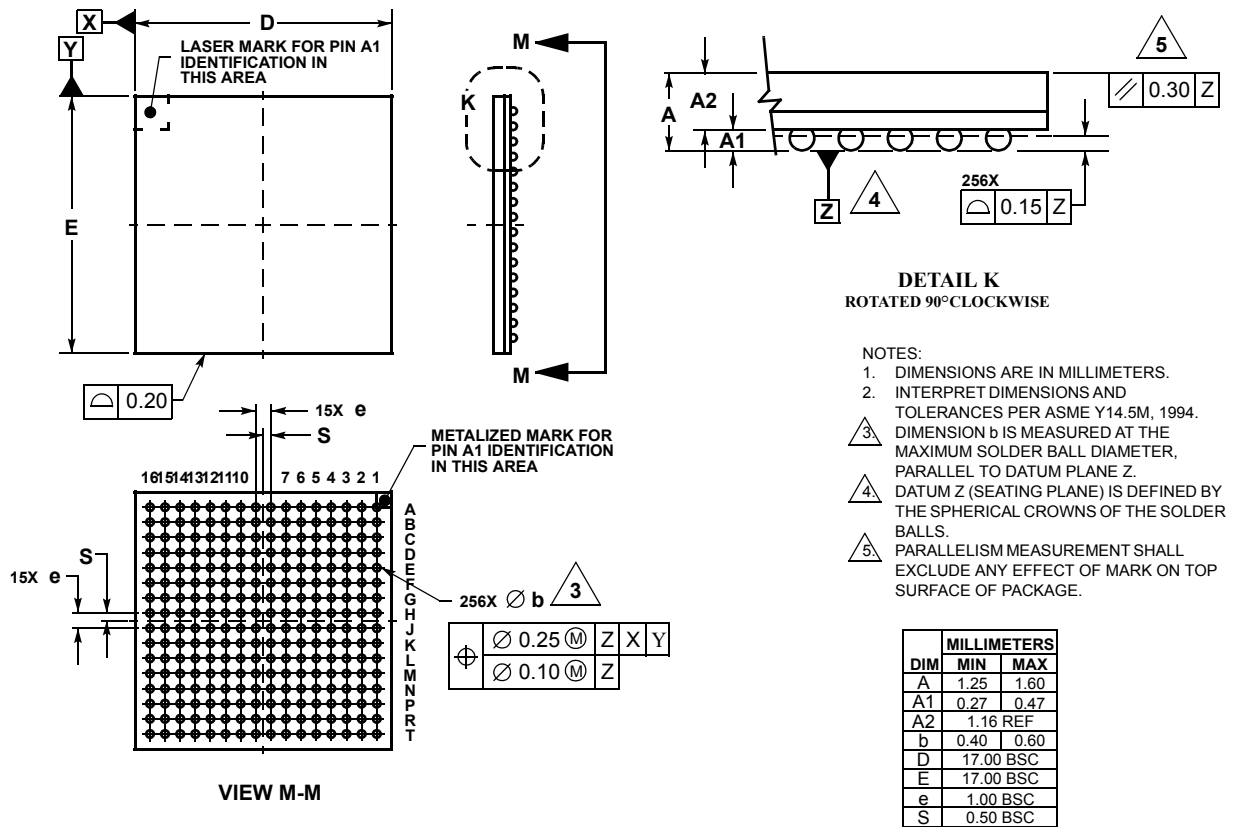

Figure 7. 256 MAPBGA Package Outline

# 5.3 Pinout—160 QFP

Figure 8 shows a pinout of the MCF5232CABxxx package.

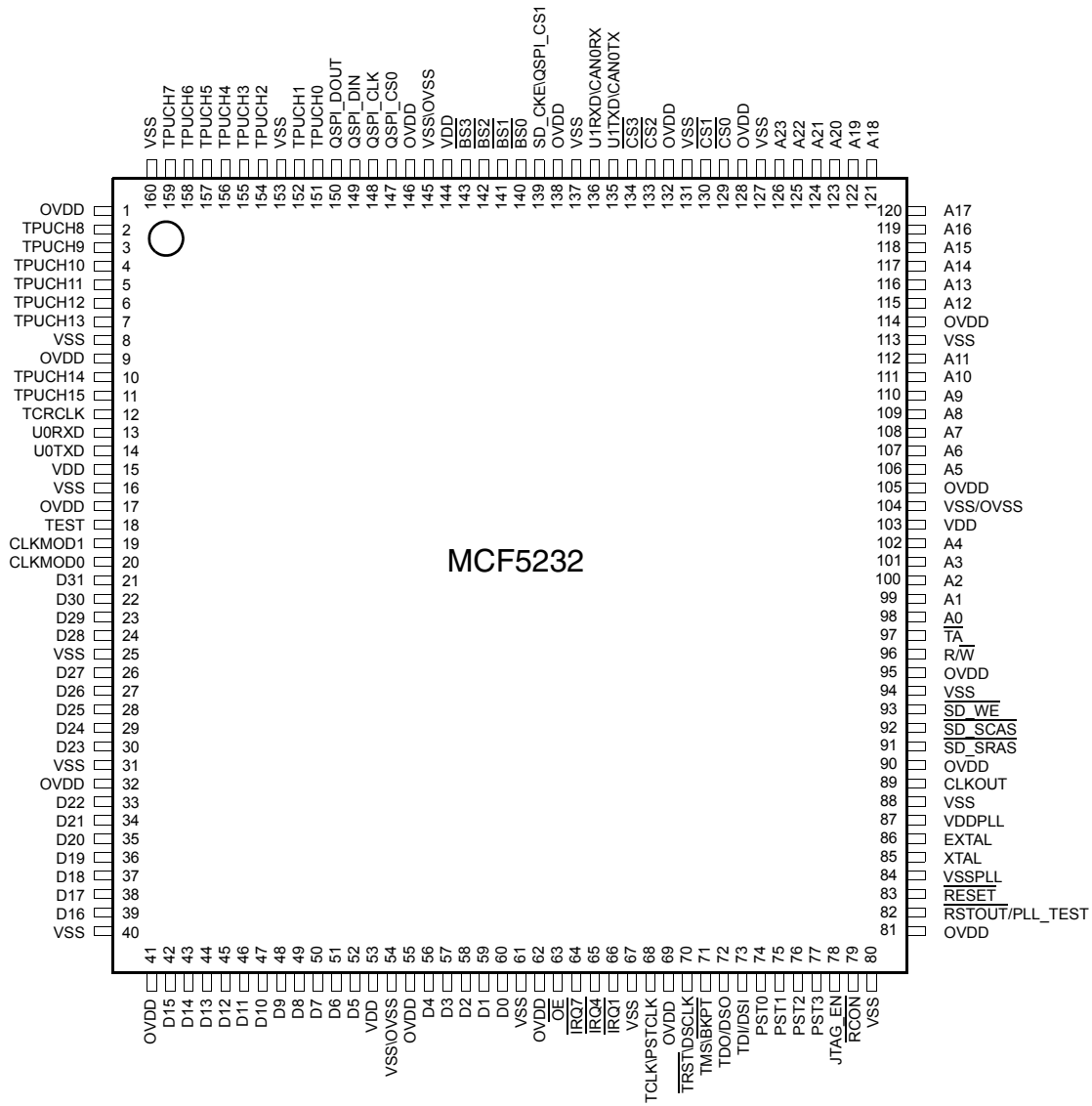
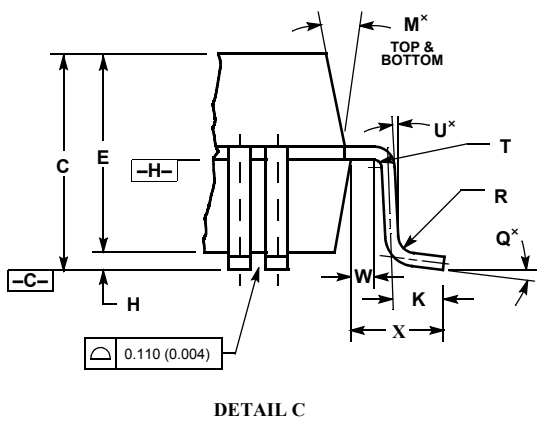
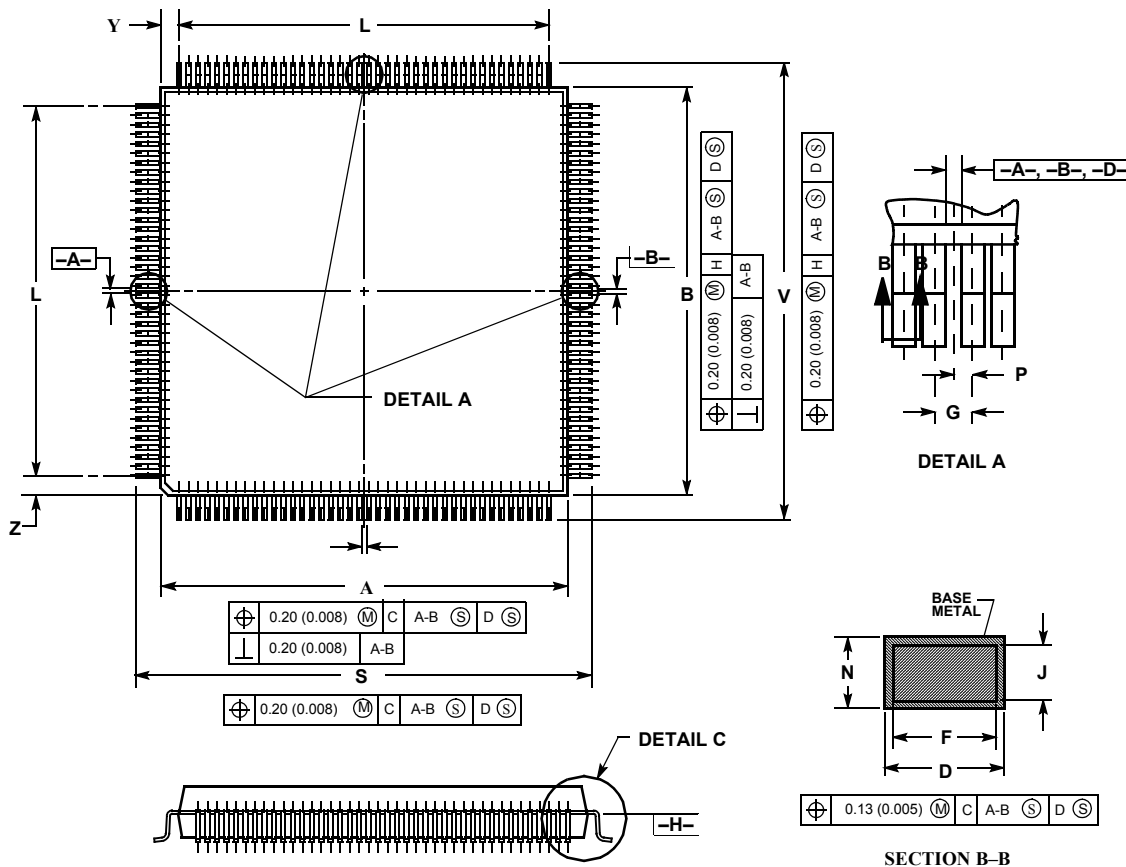

Figure 8. MCF5232CABxxx Pinout (160 QFP)



# 5.4 Package Dimensions—160 QFP

Figure 9 shows MCF5232CAB80 package dimensions.



- NOTES
1. DIMENSIONING AND TOLERANCING PER ANSI Y14.5M, 1982.
  2. CONTROLLING DIMENSION: MILLIMETER
  3. DATUM PLAN -H- IS LOCATED AT BOTTOM OF LEAD AND IS COINCIDENT WITH THE LEAD WHERE THE LEAD EXITS THE PLASTIC BODY AT THE BOTTOM OF THE PARTING LINE.
  4. DATUMS -A-, -B-, AND -D- TO BE DETERMINED AT DATUM PLANE -H-.
  5. DIMENSIONS S AND V TO BE DETERMINED AT SEATING PLANE -C-.
  6. DIMENSIONS A AND B DO NOT INCLUDE MOLD PROTRUSION. ALLOWABLE PROTRUSION IS 0.25 (0.010) PER SIDE. DIMENSIONS A AND B DO INCLUDE MOLD MISMATCH AND ARE DETERMINED AT DATUM PLANE -H-.
  7. DIMENSION D DOES NOT INCLUDE DAMBAR PROTRUSION. ALLOWABLE DAMBAR PROTRUSION SHALL BE 0.08 (0.003) TOTAL IN EXCESS OF THE D DIMENSION AT MAXIMUM MATERIAL CONDITION. DAMBAR CANNOT BE LOCATED ON THE LOWER RADIUS OR THE FOOT.

DIM	MILLIMETERS		INCHES	
	MIN	MAX	MIN	MAX
A	27.90	28.10	1.098	1.106
B	27.90	28.10	1.098	1.106
C	3.35	3.85	0.132	1.106
D	0.22	0.38	0.009	0.015
E	3.20	3.50	0.126	0.138
F	0.22	0.33	0.009	0.013
G	0.65 BSC		0.026 REF	
H	0.25	0.35	0.010	0.014
J	0.11	0.23	0.004	0.009
K	0.70	0.90	0.028	0.035
L	25.35 BSC		0.998 REF	
M	5°	16°	5°	16°
N	0.11	0.19	0.004	0.007
P	0.325 BSC		0.013 REF	
Q	0°	7°	0°	7°
R	0.13	0.30	0.005	0.012
S	31.00	31.40	1.220	1.236
T	0.13	—	0.005	—
U	0	—	0	—
V	31.00	31.40	1.220	1.236
W	0.4	—	0.016	—
X	1.60 REF		0.063 REF	
Y	1.33 REF		0.052 REF	
Z	1.33 REF		0.052 REF	

Case 864A-03

Figure 9. 160 QFP Package Dimensions

## 5.5 Ordering Information

Table 25. Orderable Part Numbers

Freescale Part Number	Description	Speed	Temperature
MCF5232CAB80	MCF5232 RISC Microprocessor, 160 QFP	80MHz	-40° to +85° C
MCF5232CVM100	MCF5232 RISC Microprocessor, 196 MAPBGA	100MHz	-40° to +85° C
MCF5232CVM150	MCF5232 RISC Microprocessor, 196 MAPBGA	150MHz	-40° to +85° C
MCF5233CVM100	MCF5233 RISC Microprocessor, 256 MAPBGA	100MHz	-40° to +85° C
MCF5233CVM150	MCF5233 RISC Microprocessor, 256 MAPBGA	150MHz	-40° to +85° C
MCF5234CVM100	MCF5234 RISC Microprocessor, 256 MAPBGA	100MHz	-40° to +85° C
MCF5234CVM150	MCF5234 RISC Microprocessor, 256 MAPBGA	150MHz	-40° to +85° C
MCF5235CVM100	MCF5235 RISC Microprocessor, 256 MAPBGA	100MHz	-40° to +85° C
MCF5235CVM150	MCF5235 RISC Microprocessor, 256 MAPBGA	150MHz	-40° to +85° C

## 6 Preliminary Electrical Characteristics

This chapter contains electrical specification tables and reference timing diagrams for the MCF5235 microcontroller unit. This section contains detailed information on power considerations, DC/AC electrical characteristics, and AC timing specifications of MCF5235.

The electrical specifications are preliminary and are from previous designs or design simulations. These specifications may not be fully tested or guaranteed at this early stage of the product life cycle, however for production silicon these specifications will be met. Finalized specifications will be published after complete characterization and device qualifications have been completed.

### NOTE

The parameters specified in this processor document supersede any values found in the module specifications.

### 6.1 Maximum Ratings

Table 26. Absolute Maximum Ratings<sup>1, 2</sup>

Rating	Symbol	Value	Unit
Core Supply Voltage	$V_{DD}$	- 0.5 to +2.0	V
Pad Supply Voltage	$OV_{DD}$	- 0.3 to +4.0	V
Clock Synthesizer Supply Voltage	$V_{DDPLL}$	- 0.3 to +4.0	V
Digital Input Voltage <sup>3</sup>	$V_{IN}$	- 0.3 to + 4.0	V

**Table 26. Absolute Maximum Ratings<sup>1, 2</sup>**

Rating	Symbol	Value	Unit
Instantaneous Maximum Current Single pin limit (applies to all pins) <sup>3,4,5</sup>	$I_D$	25	mA
Operating Temperature Range (Packaged)	$T_A$ ( $T_L - T_H$ )	- 40 to 85	°C
Storage Temperature Range	$T_{stg}$	- 65 to 150	°C

## NOTES:

- <sup>1</sup> Functional operating conditions are given in DC Electrical Specifications. Absolute Maximum Ratings are stress ratings only, and functional operation at the maxima is not guaranteed. Continued operation at these levels may affect device reliability or cause permanent damage to the device.
- <sup>2</sup> This device contains circuitry protecting against damage due to high static voltage or electrical fields; however, it is advised that normal precautions be taken to avoid application of any voltages higher than maximum-rated voltages to this high-impedance circuit. Reliability of operation is enhanced if unused inputs are tied to an appropriate logic voltage level (e.g., either  $V_{SS}$  or  $OV_{DD}$ ).
- <sup>3</sup> Input must be current limited to the value specified. To determine the value of the required current-limiting resistor, calculate resistance values for positive and negative clamp voltages, then use the larger of the two values.
- <sup>4</sup> All functional non-supply pins are internally clamped to  $V_{SS}$  and  $OV_{DD}$ .
- <sup>5</sup> Power supply must maintain regulation within operating  $OV_{DD}$  range during instantaneous and operating maximum current conditions. If positive injection current ( $V_{in} > OV_{DD}$ ) is greater than  $I_{DD}$ , the injection current may flow out of  $OV_{DD}$  and could result in external power supply going out of regulation. Insure external  $OV_{DD}$  load will shunt current greater than maximum injection current. This will be the greatest risk when the processor is not consuming power (ex; no clock). Power supply must maintain regulation within operating  $OV_{DD}$  range during instantaneous and operating maximum current conditions.

## 6.2 Thermal Characteristics

Table 27 lists thermal resistance values

**Table 27. Thermal Characteristics**

Characteristic		Symbol	256 MAPBGA	196 MAPBGA	160QFP	Unit
Junction to ambient, natural convection	Four layer board (2s2p)	$\theta_{JMA}$	26 <sup>1,2</sup>	32 <sup>3,4</sup>	40 <sup>5,6</sup>	°C/W
Junction to ambient (@200 ft/min)	Four layer board (2s2p)	$\theta_{JMA}$	23 <sup>5,6</sup>	29 <sup>5,6</sup>	36 <sup>5,6</sup>	°C/W
Junction to board		$\theta_{JB}$	15 <sup>7</sup>	20 <sup>8</sup>	25 <sup>9</sup>	°C/W
Junction to case		$\theta_{JC}$	10 <sup>10</sup>	10 <sup>11</sup>	10 <sup>12</sup>	°C/W
Junction to top of package		$\Psi_{jt}$	2 <sup>5,13</sup>	2 <sup>5,14</sup>	2 <sup>5,15</sup>	°C/W
Maximum operating junction temperature		$T_j$	TBD	TBD	TBD	°C

NOTES:

- <sup>1</sup>  $\theta_{JMA}$  and  $\Psi_{jt}$  parameters are simulated in conformance with EIA/JESD Standard 51-2 for natural convection. Freescale recommends the use of  $\theta_{JMA}$  and power dissipation specifications in the system design to prevent device junction temperatures from exceeding the rated specification. System designers should be aware that device junction temperatures can be significantly influenced by board layout and surrounding devices. Conformance to the device junction temperature specification can be verified by physical measurement in the customer's system using the  $\Psi_{jt}$  parameter, the device power dissipation, and the method described in EIA/JESD Standard 51-2.
- <sup>2</sup> Per JEDEC JESD51-6 with the board horizontal.
- <sup>3</sup>  $\theta_{JMA}$  and  $\Psi_{jt}$  parameters are simulated in conformance with EIA/JESD Standard 51-2 for natural convection. Freescale recommends the use of  $\theta_{JMA}$  and power dissipation specifications in the system design to prevent device junction temperatures from exceeding the rated specification. System designers should be aware that device junction temperatures can be significantly influenced by board layout and surrounding devices. Conformance to the device junction temperature specification can be verified by physical measurement in the customer's system using the  $\Psi_{jt}$  parameter, the device power dissipation, and the method described in EIA/JESD Standard 51-2.
- <sup>4</sup> Per JEDEC JESD51-6 with the board horizontal.
- <sup>5</sup>  $\theta_{JMA}$  and  $\Psi_{jt}$  parameters are simulated in conformance with EIA/JESD Standard 51-2 for natural convection. Freescale recommends the use of  $\theta_{JMA}$  and power dissipation specifications in the system design to prevent device junction temperatures from exceeding the rated specification. System designers should be aware that device junction temperatures can be significantly influenced by board layout and surrounding devices. Conformance to the device junction temperature specification can be verified by physical measurement in the customer's system using the  $\Psi_{jt}$  parameter, the device power dissipation, and the method described in EIA/JESD Standard 51-2.
- <sup>6</sup> Per JEDEC JESD51-6 with the board horizontal.
- <sup>7</sup> Thermal resistance between the die and the printed circuit board in conformance with JEDEC JESD51-8. Board temperature is measured on the top surface of the board near the package.
- <sup>8</sup> Thermal resistance between the die and the printed circuit board in conformance with JEDEC JESD51-8. Board temperature is measured on the top surface of the board near the package.
- <sup>9</sup> Thermal resistance between the die and the printed circuit board in conformance with JEDEC JESD51-8. Board temperature is measured on the top surface of the board near the package.
- <sup>10</sup> Thermal resistance between the die and the case top surface as measured by the cold plate method (MIL SPEC-883 Method 1012.1).
- <sup>11</sup> Thermal resistance between the die and the case top surface as measured by the cold plate method (MIL SPEC-883 Method 1012.1).
- <sup>12</sup> Thermal resistance between the die and the case top surface as measured by the cold plate method (MIL SPEC-883 Method 1012.1).
- <sup>13</sup> Thermal characterization parameter indicating the temperature difference between package top and the junction temperature per JEDEC JESD51-2. When Greek letters are not available, the thermal characterization parameter is written in conformance with Psi-JT.
- <sup>14</sup> Thermal characterization parameter indicating the temperature difference between package top and the junction temperature per JEDEC JESD51-2. When Greek letters are not available, the thermal characterization parameter is written in conformance with Psi-JT.
- <sup>15</sup> Thermal characterization parameter indicating the temperature difference between package top and the junction temperature per JEDEC JESD51-2. When Greek letters are not available, the thermal characterization parameter is written in conformance with Psi-JT.

The average chip-junction temperature ( $T_J$ ) in °C can be obtained from:

$$T_J = T_A + (P_D \times \theta_{JMA}) \quad (1)$$

Where:

$T_A$  = Ambient Temperature, °C

$\theta_{JMA}$  = Package Thermal Resistance, Junction-to-Ambient, °C/W

$P_D = P_{INT} + P_{I/O}$

$P_{INT} = I_{DD} \times V_{DD}$ , Watts - Chip Internal Power

$P_{I/O}$  = Power Dissipation on Input and Output Pins — User Determined

For most applications  $P_{I/O} < P_{INT}$  and can be ignored. An approximate relationship between  $P_D$  and  $T_J$  (if  $P_{I/O}$  is neglected) is:

$$P_D = K \div (T_J + 273^\circ C) \quad (2)$$

Solving equations 1 and 2 for K gives:

$$K = P_D \times (T_A + 273^\circ C) + \Theta_{JMA} \times P_D^2 \quad (3)$$

where K is a constant pertaining to the particular part. K can be determined from equation (3) by measuring  $P_D$  (at equilibrium) for a known  $T_A$ . Using this value of K, the values of  $P_D$  and  $T_J$  can be obtained by solving equations (1) and (2) iteratively for any value of  $T_A$ .

## 6.3 DC Electrical Specifications

Table 28. DC Electrical Specifications<sup>1</sup>

Characteristic	Symbol	Min	Max	Unit
Core Supply Voltage	$V_{DD}$	1.35	1.65	V
Pad Supply Voltage	$OV_{DD}$	3	3.6	V
Input High Voltage	$V_{IH}$	$0.7 \times OV_{DD}$	3.65	V
Input Low Voltage	$V_{IL}$	$V_{SS} - 0.3$	$0.35 \times OV_{DD}$	V
Input Hysteresis	$V_{HYS}$	$0.06 \times OV_{DD}$	—	mV
Input Leakage Current $V_{in} = V_{DD}$ or $V_{SS}$ , Input-only pins	$I_{in}$	-1.0	1.0	$\mu A$
High Impedance (Off-State) Leakage Current $V_{in} = V_{DD}$ or $V_{SS}$ , All input/output and output pins	$I_{OZ}$	-1.0	1.0	$\mu A$
Output High Voltage (All input/output and all output pins) $I_{OH} = -5.0$ mA	$V_{OH}$	$OV_{DD} - 0.5$	—	V
Output Low Voltage (All input/output and all output pins) $I_{OL} = 5.0$ mA	$V_{OL}$	—	0.5	V
Weak Internal Pull Up Device Current, tested at $V_{IL}$ Max. <sup>2</sup>	$I_{APU}$	-10	-130	$\mu A$
Input Capacitance <sup>3</sup> All input-only pins All input/output (three-state) pins	$C_{in}$	— —	7 7	pF

**Table 28. DC Electrical Specifications<sup>1</sup>**

Characteristic	Symbol	Min	Max	Unit
Load Capacitance <sup>4</sup> Low drive strength High drive strength	$C_L$		25 50	pF
Core Operating Supply Current <sup>5</sup> Master Mode	$I_{DD}$	—	TBD	mA
Pad Operating Supply Current Master Mode Low Power Modes	$O_{DD}$	— —	TBD TBD	mA $\mu$ A
DC Injection Current <sup>3, 6, 7, 8</sup> $V_{NEGCLAMP} = V_{SS} - 0.3$ V, $V_{POSCLAMP} = V_{DD} + 0.3$ Single Pin Limit Total processor Limit, Includes sum of all stressed pins	$I_{IC}$	-1.0 -10	1.0 10	mA

NOTES:

- <sup>1</sup> Refer to Table 29 for additional PLL specifications.
- <sup>2</sup> Refer to the MCF5235 signals section for pins having weak internal pull-up devices.
- <sup>3</sup> This parameter is characterized before qualification rather than 100% tested.
- <sup>4</sup> pF load ratings are based on DC loading and are provided as an indication of driver strength. High speed interfaces require transmission line analysis to determine proper drive strength and termination. See [High Speed Signal Propagation: Advanced Black Magic](#) by Howard W. Johnson for design guidelines.
- <sup>5</sup> Current measured at maximum system clock frequency, all modules active, and default drive strength with matching load.
- <sup>6</sup> All functional non-supply pins are internally clamped to  $V_{SS}$  and their respective  $V_{DD}$ .
- <sup>7</sup> Input must be current limited to the value specified. To determine the value of the required current-limiting resistor, calculate resistance values for positive and negative clamp voltages, then use the larger of the two values.
- <sup>8</sup> Power supply must maintain regulation within operating  $V_{DD}$  range during instantaneous and operating maximum current conditions. If positive injection current ( $V_{in} > V_{DD}$ ) is greater than  $I_{DD}$ , the injection current may flow out of  $V_{DD}$  and could result in external power supply going out of regulation. Insure external  $V_{DD}$  load will shunt current greater than maximum injection current. This will be the greatest risk when the processor is not consuming power. Examples are: if no system clock is present, or if clock rate is very low which would reduce overall power consumption. Also, at power-up, system clock is not present during the power-up sequence until the PLL has attained lock.

## 6.4 Oscillator and PLLMRFM Electrical Characteristics

**Table 29. HiP7 PLLMRFM Electrical Specifications<sup>1</sup>**

Num	Characteristic	Symbol	Min. Value	Max. Value	Unit
1	PLL Reference Frequency Range Crystal reference External reference 1:1 mode (NOTE: $f_{sys/2} = 2 \times f_{ref\_1:1}$ )	$f_{ref\_crystal}$ $f_{ref\_ext}$ $f_{ref\_1:1}$	8 8 24	25 25 75	MHz
2	Core frequency CLKOUT Frequency <sup>2</sup> External reference On-Chip PLL Frequency	$f_{sys}$ $f_{sys/2}$	0 $f_{ref} \div 32$	150 75 75	MHz MHz MHz
3	Loss of Reference Frequency <sup>3, 5</sup>	$f_{LOR}$	100	1000	kHz
4	Self Clocked Mode Frequency <sup>4, 5</sup>	$f_{SCM}$	TBD	TBD	MHz

Table 29. HiP7 PLLMRFM Electrical Specifications<sup>1</sup>

Num	Characteristic	Symbol	Min. Value	Max. Value	Unit
5	Crystal Start-up Time <sup>5, 6</sup>	$t_{cst}$	—	10	ms
6	EXTAL Input High Voltage Crystal Mode <sup>7</sup> All other modes (Dual Controller (1:1), Bypass, External)	$V_{IHEXT}$ $V_{IHEXT}$	TBD TBD	TBD TBD	V V
7	EXTAL Input Low Voltage Crystal Mode <sup>7</sup> All other modes (Dual Controller (1:1), Bypass, External)	$V_{ILEXT}$ $V_{ILEXT}$	TBD TBD	TBD TBD	V V
8	XTAL Output High Voltage $I_{OH} = 1.0$ mA	$V_{OH}$	TBD	—	V
9	XTAL Output Low Voltage $I_{OL} = 1.0$ mA	$V_{OL}$	—	TBD	V
10	XTAL Load Capacitance <sup>5</sup>		5	30	pF
11	PLL Lock Time <sup>5, 8, 14</sup>	$t_{pll}$	—	750	$\mu$ s
12	Power-up To Lock Time <sup>5, 6, 9</sup> With Crystal Reference (includes 5 time) Without Crystal Reference <sup>10</sup>	$t_{plk}$	— —	11 750	ms $\mu$ s
13	1:1 Mode Clock Skew (between CLKOUT and EXTAL) <sup>11</sup>	$t_{skew}$	–1	1	ns
14	Duty Cycle of reference <sup>5</sup>	$t_{dc}$	40	60	%
15	Frequency un-LOCK Range	$f_{UL}$	–3.8	4.1	% $f_{sys/2}$
16	Frequency LOCK Range	$f_{LCK}$	–1.7	2.0	% $f_{sys/2}$
17	CLKOUT Period Jitter, <sup>5, 6, 9, 12, 13</sup> Measured at $f_{sys/2}$ Max Peak-to-peak Jitter (Clock edge to clock edge) Long Term Jitter (Averaged over 2 ms interval)	$C_{jitter}$	— —	5.0 .01	% $f_{sys/2}$
18	Frequency Modulation Range Limit <sup>14, 15</sup> ( $f_{sys/2}$ Max must not be exceeded)	$C_{mod}$	0.8	2.2	% $f_{sys/2}$
19	ICO Frequency. $f_{ico} = f_{ref} * 2 * (MFD+2)$ <sup>16</sup>	$f_{ico}$	48	75	MHz

## NOTES:

- <sup>1</sup> All values given are initial design targets and subject to change.
- <sup>2</sup> All internal registers retain data at 0 Hz.
- <sup>3</sup> “Loss of Reference Frequency” is the reference frequency detected internally, which transitions the PLL into self clocked mode.
- <sup>4</sup> Self clocked mode frequency is the frequency that the PLL operates at when the reference frequency falls below  $f_{LOR}$  with default MFD/RFD settings.
- <sup>5</sup> This parameter is guaranteed by characterization before qualification rather than 100% tested.
- <sup>6</sup> Proper PC board layout procedures must be followed to achieve specifications.
- <sup>7</sup> This parameter is guaranteed by design rather than 100% tested.

## Preliminary Electrical Characteristics

- <sup>8</sup> This specification applies to the period required for the PLL to relock after changing the MFD frequency control bits in the synthesizer control register (SYNCR).
- <sup>9</sup> Assuming a reference is available at power up, lock time is measured from the time  $V_{DD}$  and  $V_{DDSYN}$  are valid to  $\overline{RSTOUT}$  negating. If the crystal oscillator is being used as the reference for the PLL, then the crystal start up time must be added to the PLL lock time to determine the total start-up time.
- <sup>10</sup>  $t_{ipll} = (64 \cdot 4 \cdot 5 + 5 \times \tau) \times T_{ref}$ , where  $T_{ref} = 1/F_{ref\_crystal} = 1/F_{ref\_ext} = 1/F_{ref\_1:1}$ , and  $\tau = 1.57 \times 10^{-6} \times 2(MFD + 2)$ .
- <sup>11</sup> PLL is operating in 1:1 PLL mode.
- <sup>12</sup> Jitter is the average deviation from the programmed frequency measured over the specified interval at maximum  $f_{sys/2}$ . Measurements are made with the device powered by filtered supplies and clocked by a stable external clock signal. Noise injected into the PLL circuitry via  $V_{DDSYN}$  and  $V_{SSSYN}$  and variation in crystal oscillator frequency increase the Cjitter percentage for a given interval.
- <sup>13</sup> Values are with frequency modulation disabled. If frequency modulation is enabled, jitter is the sum of Cjitter+Cmod.
- <sup>14</sup> Modulation percentage applies over an interval of 10 $\mu$ s, or equivalently the modulation rate is 100KHz.
- <sup>15</sup> Modulation rate selected must not result in  $f_{sys/2}$  value greater than the  $f_{sys/2}$  maximum specified value. Modulation range determined by hardware design.
- <sup>16</sup>  $f_{sys/2} = f_{ico} / (2 \cdot 2^{RFD})$

## 6.5 External Interface Timing Characteristics

Table 30 lists processor bus input timings.

### NOTE

All processor bus timings are synchronous; that is, input setup/hold and output delay with respect to the rising edge of a reference clock. The reference clock is the CLKOUT output.

All other timing relationships can be derived from these values.

**Table 30. Processor Bus Input Timing Specifications**

Name	Characteristic <sup>1</sup>	Symbol	Min	Max	Unit
freq	System bus frequency	$f_{sys/2}$	50	50	MHz
B0	CLKOUT period	$t_{cyc}$		1/50	ns
Control Inputs					
B1a	Control input valid to CLKOUT high <sup>2</sup>	$t_{CVCH}$	9	—	ns
B1b	$\overline{BKPT}$ valid to CLKOUT high <sup>3</sup>	$t_{BKVCH}$	9	—	ns
B2a	CLKOUT high to control inputs invalid <sup>2</sup>	$t_{CHCII}$	0	—	ns
B2b	CLKOUT high to asynchronous control input $\overline{BKPT}$ invalid <sup>3</sup>	$t_{BKNCH}$	0	—	ns
Data Inputs					
B4	Data input (D[31:0]) valid to CLKOUT high	$t_{DIVCH}$	4	—	ns
B5	CLKOUT high to data input (D[31:0]) invalid	$t_{CHDII}$	0	—	ns

#### NOTES:

<sup>1</sup> Timing specifications are tested using full drive strength pad configurations in a 50ohm transmission line environment..

<sup>2</sup>  $\overline{TEA}$  and  $\overline{TA}$  pins are being referred to as control inputs.

<sup>3</sup> Refer to figure A-19.



Timings listed in Table 30 are shown in Figure 10 & Figure A-3.

\* The timings are also valid for inputs sampled on the negative clock edge.

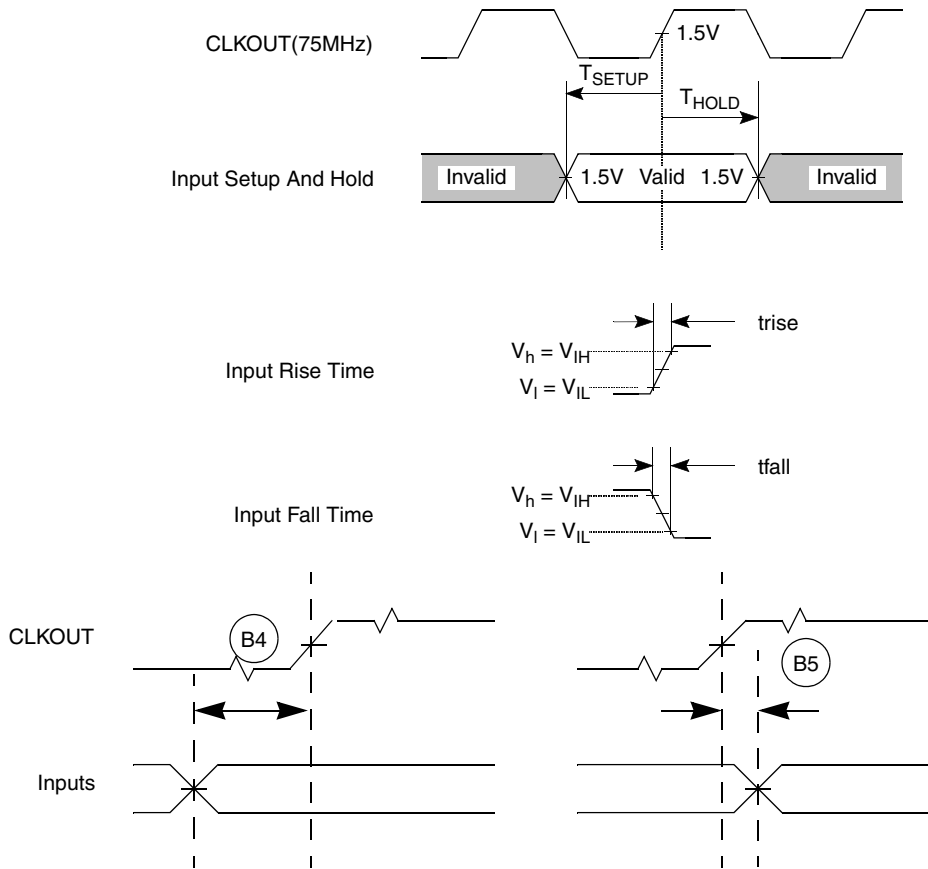

Figure 10. General Input Timing Requirements

## 6.6 Processor Bus Output Timing Specifications

Table 31 lists processor bus output timings.

Table 31. External Bus Output Timing Specifications

Name	Characteristic	Symbol	Min	Max	Unit
Control Outputs					
B6a	CLKOUT high to chip selects valid <sup>1</sup>	$t_{CHCV}$	—	$0.5t_{CYC} + 5$	ns
B6b	CLKOUT high to byte enables ( $\overline{BS}[3:0]$ ) valid <sup>2</sup>	$t_{CHBV}$	—	$0.5t_{CYC} + 5$	ns
B6c	CLKOUT high to output enable ( $\overline{OE}$ ) valid <sup>3</sup>	$t_{CHOV}$	—	$0.5t_{CYC} + 5$	ns
B7	CLKOUT high to control output ( $\overline{BS}[3:0]$ , $\overline{OE}$ ) invalid	$t_{CHCOI}$	$0.5t_{CYC} + 1.5$	—	ns
B7a	CLKOUT high to chip selects invalid	$t_{CHCI}$	$0.5t_{CYC} + 1.5$	—	ns

Table 31. External Bus Output Timing Specifications (continued)

Name	Characteristic	Symbol	Min	Max	Unit
Address and Attribute Outputs					
B8	CLKOUT high to address (A[23:0]) and control ( $\overline{TS}$ , $\overline{TSIZ}[1:0]$ , $\overline{TIP}$ , R/ $\overline{W}$ ) valid	$t_{CHAV}$	—	9	ns
B9	CLKOUT high to address (A[23:0]) and control ( $\overline{TS}$ , $\overline{TSIZ}[1:0]$ , $\overline{TIP}$ , R/ $\overline{W}$ ) invalid	$t_{CHAI}$	1.5	—	ns
Data Outputs					
B11	CLKOUT high to data output (D[31:0]) valid	$t_{CHDOV}$	—	9	ns
B12	CLKOUT high to data output (D[31:0]) invalid	$t_{CHDOI}$	1.5	—	ns
B13	CLKOUT high to data output (D[31:0]) high impedance	$t_{CHDOZ}$	—	9	ns

## NOTES:

- <sup>1</sup>  $\overline{CS}$  transitions after the falling edge of CLKOUT.
- <sup>2</sup>  $\overline{BS}$  transitions after the falling edge of CLKOUT.
- <sup>3</sup>  $\overline{OE}$  transitions after the falling edge of CLKOUT.

Read/write bus timings listed in Table 31 are shown in Figure 11, Figure 12, and Figure 13.

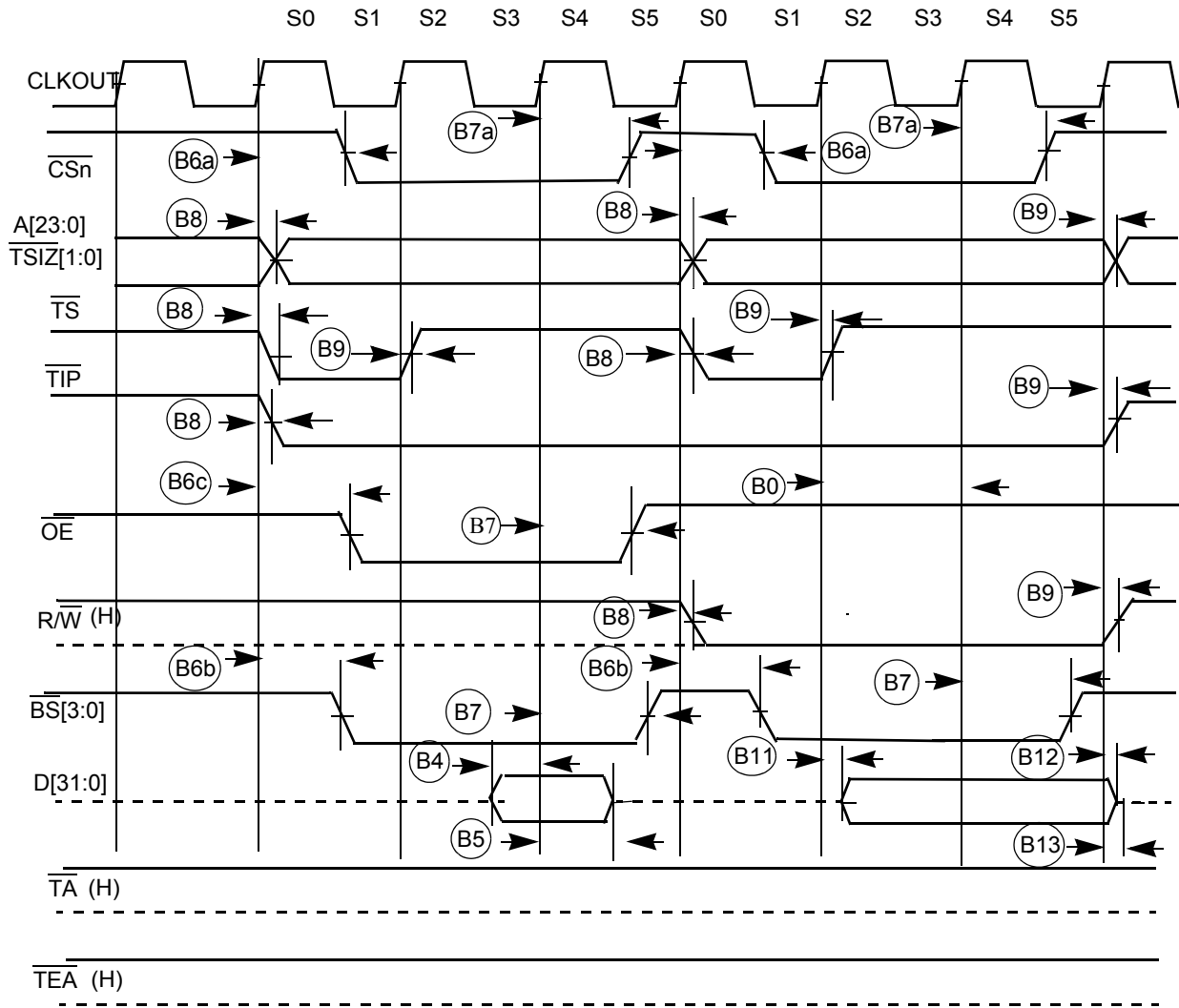

Figure 11. Read/Write (Internally Terminated) SRAM Bus Timing

Figure 12 shows a bus cycle terminated by  $\overline{TA}$  showing timings listed in Table 31.

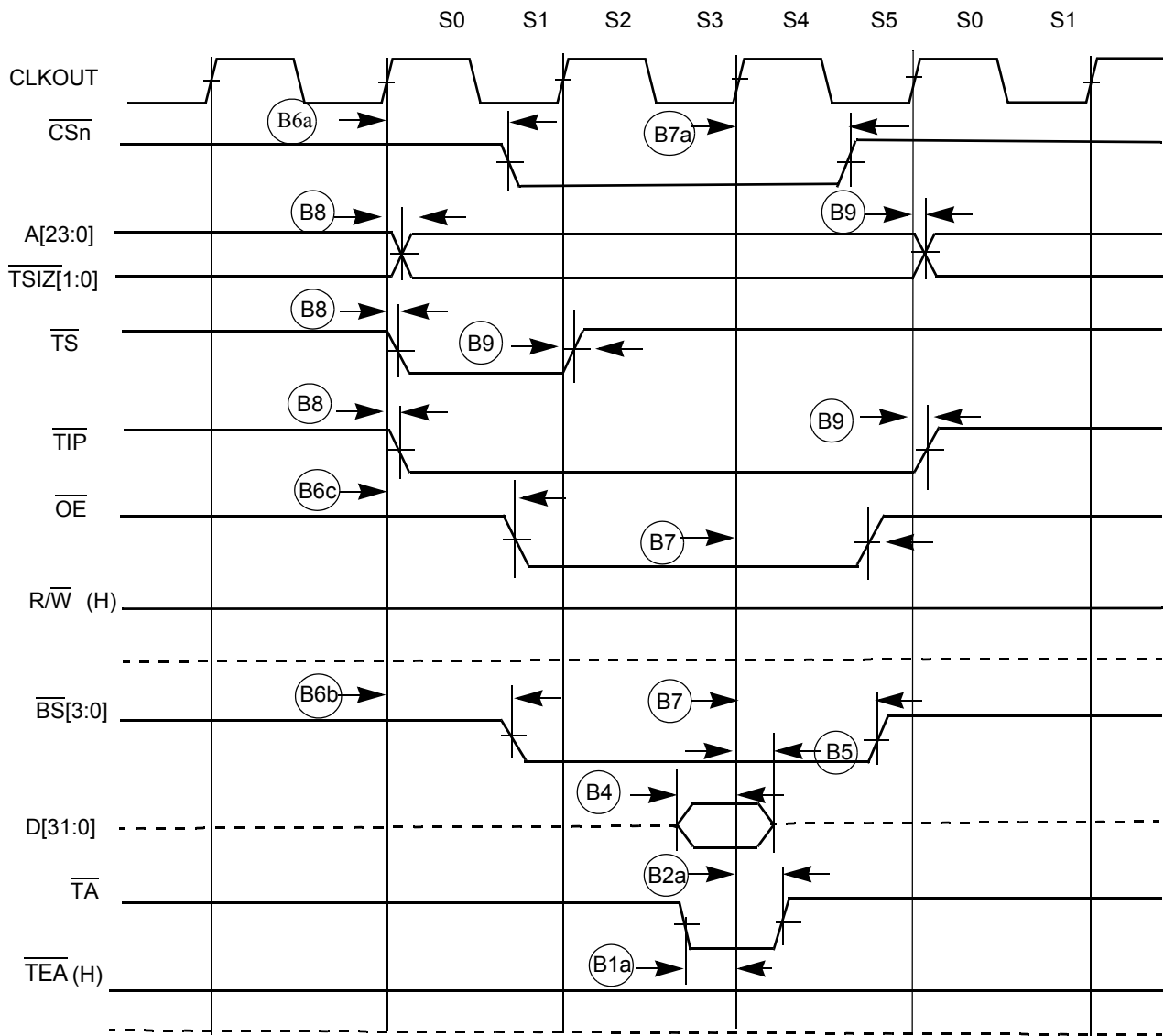

Figure 12. SRAM Read Bus Cycle Terminated by  $\overline{TA}$

Figure 13 shows an SRAM bus cycle terminated by  $\overline{TEA}$  showing timings listed in Table 31.

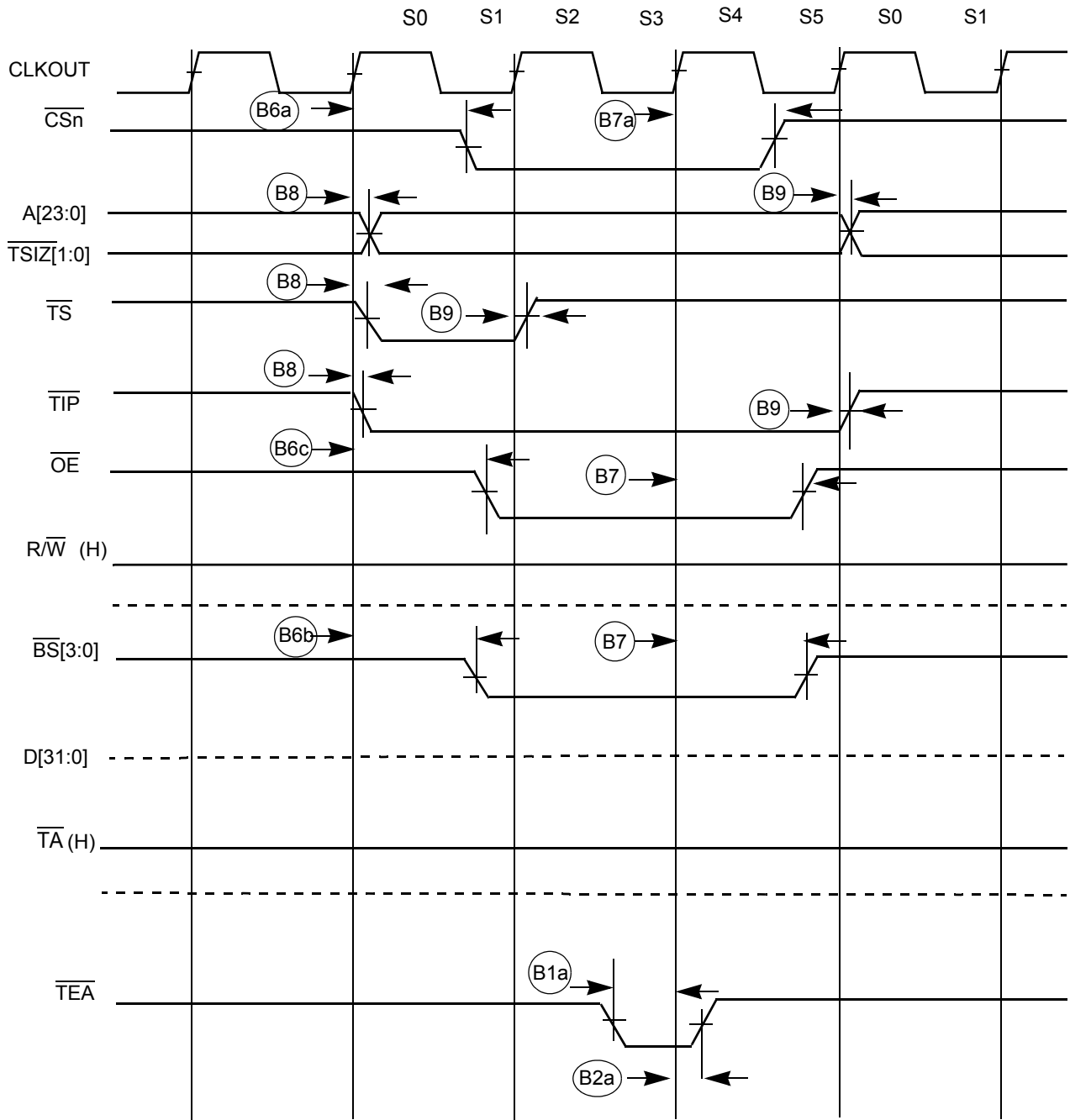

Figure 13. SRAM Read Bus Cycle Terminated by  $\overline{TEA}$

Figure 14 shows an SDRAM read cycle.

Preliminary Electrical Characteristics

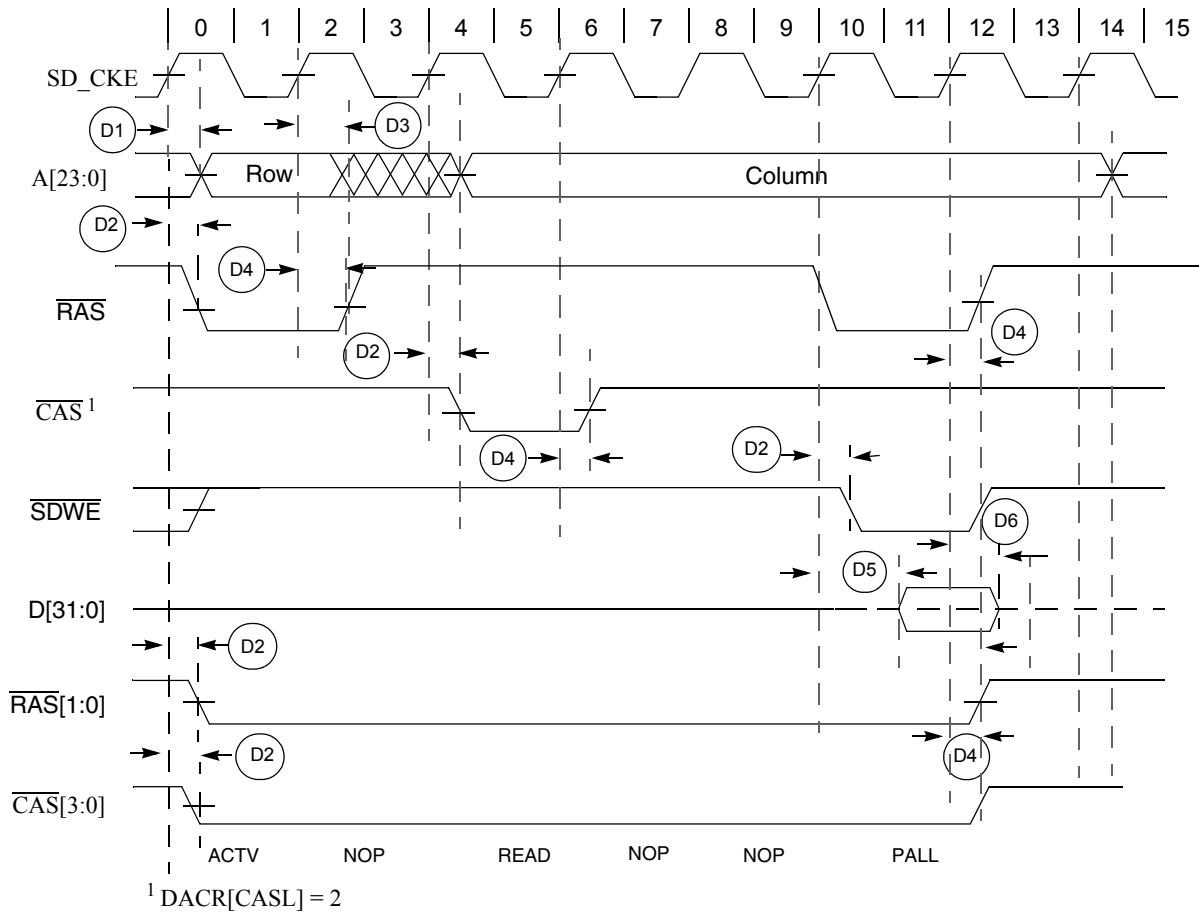

Figure 14. SDRAM Read Cycle

Table 32. SDRAM Timing

NUM	Characteristic	Symbol	Min	Max	Unit
D1	CLKOUT high to SDRAM address valid	$t_{CHDAV}$	—	9	ns
D2	CLKOUT high to SDRAM control valid	$t_{CHDCV}$	—	9	ns
D3	CLKOUT high to SDRAM address invalid	$t_{CHDAI}$	1.5	—	ns
D4	CLKOUT high to SDRAM control invalid	$t_{CHDCI}$	1.5	—	ns
D5	SDRAM data valid to CLKOUT high	$t_{DDVCH}$	4	—	ns
D6	CLKOUT high to SDRAM data invalid	$t_{CHDDI}$	1.5	—	ns
D7 <sup>1</sup>	CLKOUT high to SDRAM data valid	$t_{CHDDVW}$	—	9	ns
D8 <sup>2</sup>	CLKOUT high to SDRAM data invalid	$t_{CHDDIW}$	1.5	—	ns

NOTES:

<sup>1</sup> D7 and D8 are for write cycles only.

Figure 15 shows an SDRAM write cycle.

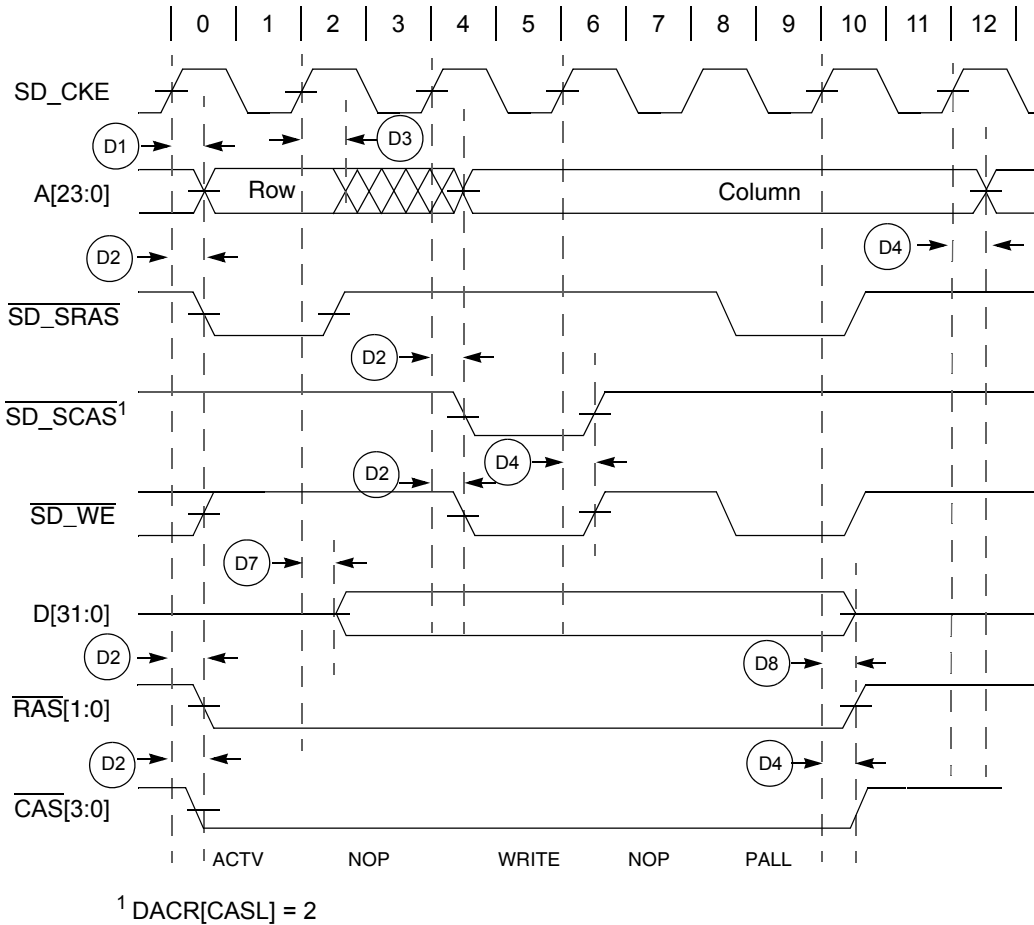

Figure 15. SDRAM Write Cycle

## 6.7 General Purpose I/O Timing

Table 33. GPIO Timing<sup>1</sup>

NUM	Characteristic	Symbol	Min	Max	Unit
G1 G2	CLKOUT High to GPIO Output Valid	t <sub>CHPOV</sub>	—	10	ns
	CLKOUT High to GPIO Output Invalid	t <sub>CHPOI</sub>	1.5	—	ns
G3 G4	GPIO Input Valid to CLKOUT High	t <sub>PVCH</sub>	9	—	ns
	CLKOUT High to GPIO Input Invalid	t <sub>CHPI</sub>	1.5	—	ns

NOTES:

<sup>1</sup> GPIO pins include: INT, ETPU, UART, FlexCAN and Timer pins.

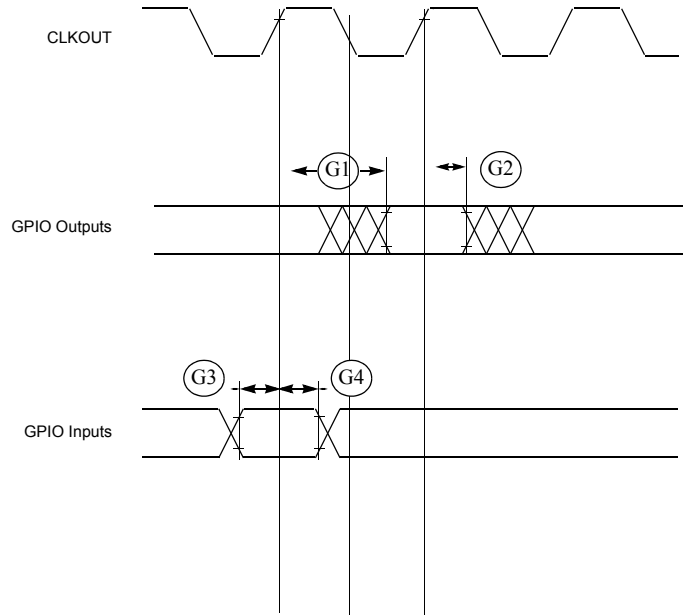

Figure 16. GPIO Timing

## 6.8 Reset and Configuration Override Timing

Table 34. Reset and Configuration Override Timing

( $V_{DD} = 2.7$  to  $3.6$  V,  $V_{SS} = 0$  V,  $T_A = T_L$  to  $T_H$ )<sup>1</sup>

NUM	Characteristic	Symbol	Min	Max	Unit
R1	$\overline{\text{RESET}}$ Input valid to CLKOUT High	$t_{RVCH}$	9	—	ns
R2	CLKOUT High to $\overline{\text{RESET}}$ Input invalid	$t_{CHRI}$	1.5	—	ns
R3	$\overline{\text{RESET}}$ Input valid Time <sup>2</sup>	$t_{RIVT}$	5	—	$t_{CYC}$
R4	CLKOUT High to $\overline{\text{RSTOUT}}$ Valid	$t_{CHROV}$	—	10	ns
R5	$\overline{\text{RSTOUT}}$ valid to Config. Overrides valid	$t_{ROVCV}$	0	—	ns
R6	Configuration Override Setup Time to $\overline{\text{RSTOUT}}$ invalid	$t_{COS}$	20	—	$t_{CYC}$
R7	Configuration Override Hold Time after $\overline{\text{RSTOUT}}$ invalid	$t_{COH}$	0	—	ns
R8	$\overline{\text{RSTOUT}}$ invalid to Configuration Override High Impedance	$t_{ROICZ}$	—	1	$t_{CYC}$

NOTES:

<sup>1</sup> All AC timing is shown with respect to 50%  $V_{DD}$  levels unless otherwise noted.

<sup>2</sup> During low power STOP, the synchronizers for the  $\overline{\text{RESET}}$  input are bypassed and  $\overline{\text{RESET}}$  is asserted asynchronously to the system. Thus,  $\overline{\text{RESET}}$  must be held a minimum of 100 ns.



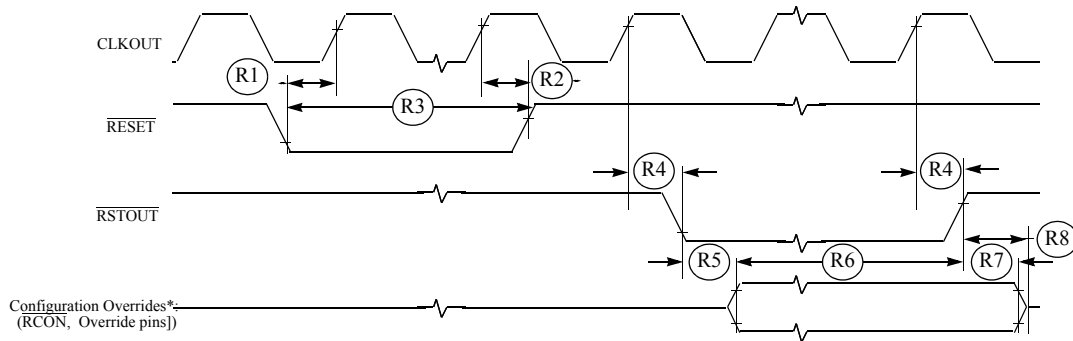

Figure 17.  $\overline{\text{RESET}}$  and Configuration Override Timing

\* Refer to the Coldfire Integration Module (CIM) section for more information.

## 6.9 I<sup>2</sup>C Input/Output Timing Specifications

Table 35 lists specifications for the I<sup>2</sup>C input timing parameters shown in Figure 18.

Table 35. I<sup>2</sup>C Input Timing Specifications between I2C\_SCL and I2C\_SDA

Num	Characteristic	Min	Max	Units
I1	Start condition hold time	2	—	t <sub>cyc</sub>
I2	Clock low period	8	—	t <sub>cyc</sub>
I3	I2C_SCL/I2C_SDA rise time (V <sub>IL</sub> = 0.5 V to V <sub>IH</sub> = 2.4 V)	—	1	ms
I4	Data hold time	0	—	ns
I5	I2C_SCL/I2C_SDA fall time (V <sub>IH</sub> = 2.4 V to V <sub>IL</sub> = 0.5 V)	—	1	ms
I6	Clock high time	4	—	t <sub>cyc</sub>
I7	Data setup time	0	—	ns
I8	Start condition setup time (for repeated start condition only)	2	—	t <sub>cyc</sub>
I9	Stop condition setup time	2	—	t <sub>cyc</sub>

Table 36 lists specifications for the I<sup>2</sup>C output timing parameters shown in Figure 18.

Table 36. I<sup>2</sup>C Output Timing Specifications between I2C\_SCL and I2C\_SDA

Num	Characteristic	Min	Max	Units
I1 <sup>1</sup>	Start condition hold time	6	—	t <sub>cyc</sub>
I2 <sup>1</sup>	Clock low period	10	—	t <sub>cyc</sub>
I3 <sup>2</sup>	I2C_SCL/I2C_SDA rise time (V <sub>IL</sub> = 0.5 V to V <sub>IH</sub> = 2.4 V)	—	—	μs
I4 <sup>1</sup>	Data hold time	7	—	t <sub>cyc</sub>
I5 <sup>3</sup>	I2C_SCL/I2C_SDA fall time (V <sub>IH</sub> = 2.4 V to V <sub>IL</sub> = 0.5 V)	—	3	ns
I6 <sup>1</sup>	Clock high time	10	—	t <sub>cyc</sub>

**Table 36. I<sup>2</sup>C Output Timing Specifications between I2C\_SCL and I2C\_SDA**

Num	Characteristic	Min	Max	Units
17 <sup>1</sup>	Data setup time	2	—	t <sub>cyc</sub>
18 <sup>1</sup>	Start condition setup time (for repeated start condition only)	20	—	t <sub>cyc</sub>
19 <sup>1</sup>	Stop condition setup time	10	—	t <sub>cyc</sub>

NOTES:

- <sup>1</sup> Note: Output numbers depend on the value programmed into the IFDR; an IFDR programmed with the maximum frequency (IFDR = 0x20) results in minimum output timings as shown in Table 36. The I<sup>2</sup>C interface is designed to scale the actual data transition time to move it to the middle of the I2C\_SCL low period. The actual position is affected by the prescale and division values programmed into the IFDR; however, the numbers given in Table 36 are minimum values.
- <sup>2</sup> Because I2C\_SCL and I2C\_SDA are open-collector-type outputs, which the processor can only actively drive low, the time I2C\_SCL or I2C\_SDA take to reach a high level depends on external signal capacitance and pull-up resistor values.
- <sup>3</sup> Specified at a nominal 50-pF load.

Figure 18 shows timing for the values in Table 35 and Table 36.

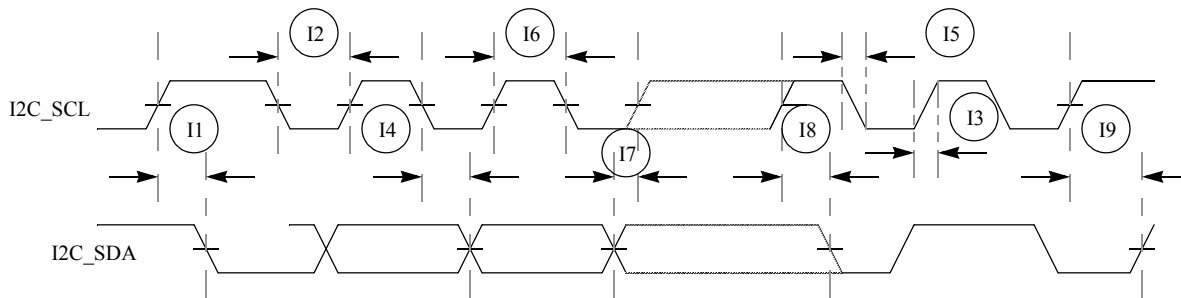

**Figure 18. I<sup>2</sup>C Input/Output Timings**

## 6.10 Fast Ethernet AC Timing Specifications

MII signals use TTL signal levels compatible with devices operating at either 5.0 V or 3.3 V.

### 6.10.1 MII Receive Signal Timing (ERXD[3:0], ERXDV, ERXER, and ERXCLK)

The receiver functions correctly up to a ERXCLK maximum frequency of 25 MHz +1%. There is no minimum frequency requirement. In addition, the processor clock frequency must exceed twice the ERXCLK frequency.

Table 37 lists MII receive channel timings.

**Table 37. MII Receive Signal Timing**

Num	Characteristic	Min	Max	Unit
M1	ERXD[3:0], ERXDV, ERXER to ERXCLK setup	5	—	ns
M2	ERXCLK to ERXD[3:0], ERXDV, ERXER hold	5	—	ns
M3	ERXCLK pulse width high	35%	65%	ERXCLK period
M4	ERXCLK pulse width low	35%	65%	ERXCLK period

Figure 19 shows MII receive signal timings listed in Table 37.

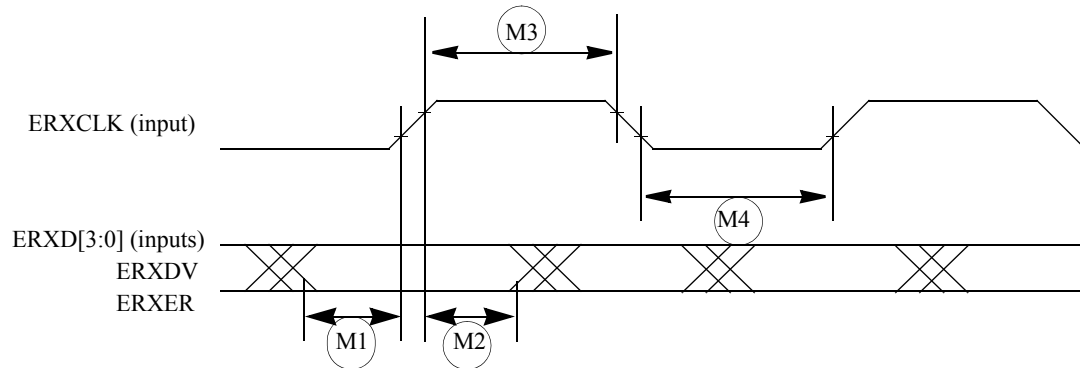

**Figure 19. MII Receive Signal Timing Diagram**

### 6.10.2 MII Transmit Signal Timing (ETXD[3:0], ETXEN, ETXER, ETXCLK)

Table 38 lists MII transmit channel timings.

The transmitter functions correctly up to a ETXCLK maximum frequency of 25 MHz +1%. There is no minimum frequency requirement. In addition, the processor clock frequency must exceed twice the ETXCLK frequency.

The transmit outputs (ETXD[3:0], ETXEN, ETXER) can be programmed to transition from either the rising or falling edge of ETXCLK, and the timing is the same in either case. This options allows the use of non-compliant MII PHYs.

Refer to the Ethernet chapter for details of this option and how to enable it.

**Table 38. MII Transmit Signal Timing**

Num	Characteristic	Min	Max	Unit
M5	ETXCLK to ETXD[3:0], ETXEN, ETXER invalid	5	—	ns
M6	ETXCLK to ETXD[3:0], ETXEN, ETXER valid	—	25	ns
M7	ETXCLK pulse width high	35%	65%	ETXCLK period
M8	ETXCLK pulse width low	35%	65%	ETXCLK period

Figure 20 shows MII transmit signal timings listed in Table 38.

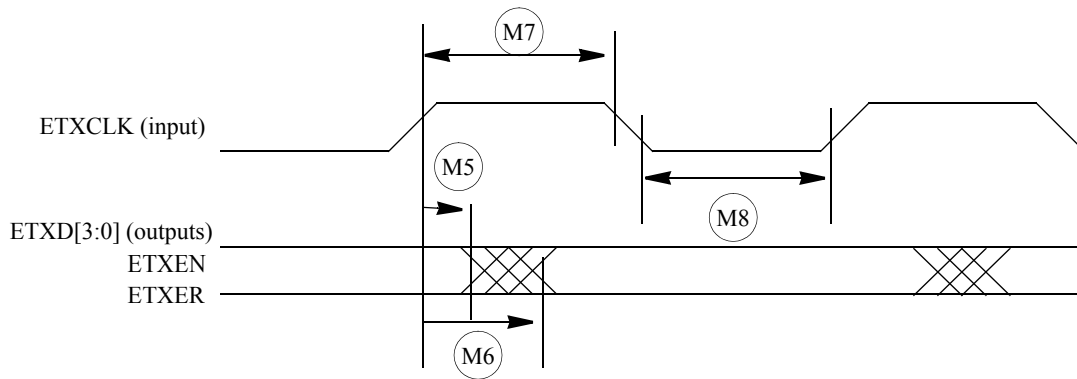

Figure 20. MII Transmit Signal Timing Diagram

### 6.10.3 MII Async Inputs Signal Timing (ECSR and ECOL)

Table 39 lists MII asynchronous inputs signal timing.

Table 39. MII Async Inputs Signal Timing

Num	Characteristic	Min	Max	Unit
M9	ECSR, ECOL minimum pulse width	1.5	—	ETXCLK period

Figure 21 shows MII asynchronous input timings listed in Table 39.

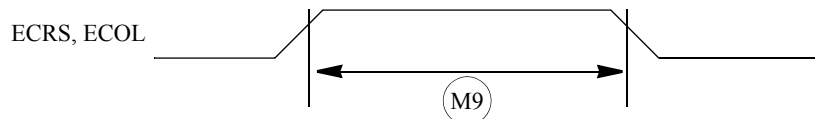

Figure 21. MII Async Inputs Timing Diagram

### 6.10.4 MII Serial Management Channel Timing (EMDIO and EMDC)

Table 40 lists MII serial management channel timings. The FEC functions correctly with a maximum MDC frequency of 2.5 MHz.

Table 40. MII Serial Management Channel Timing

Num	Characteristic	Min	Max	Unit
M10	EMDC falling edge to EMDIO output invalid (minimum propagation delay)	0	—	ns
M11	EMDC falling edge to EMDIO output valid (max prop delay)	—	25	ns
M12	EMDIO (input) to EMDC rising edge setup	10	—	ns
M13	EMDIO (input) to EMDC rising edge hold	0	—	ns
M14	EMDC pulse width high	40%	60%	MDC period
M15	EMDC pulse width low	40%	60%	MDC period

Figure 22 shows MII serial management channel timings listed in Table 40.

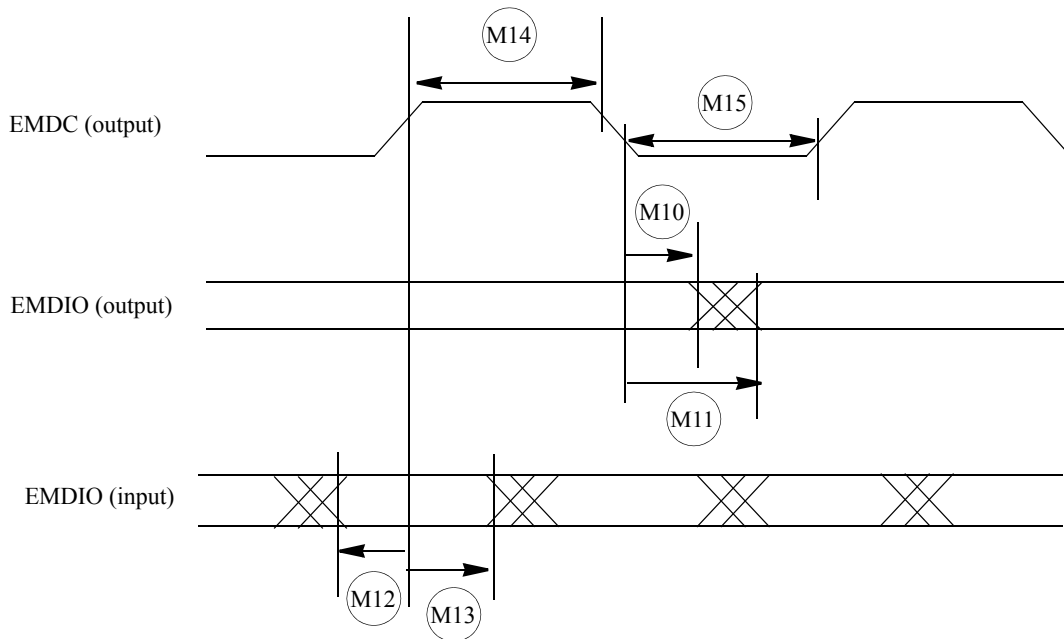

Figure 22. MII Serial Management Channel Timing Diagram

## 6.11 32-Bit Timer Module AC Timing Specifications

Table 41 lists timer module AC timings.

Table 41. Timer Module AC Timing Specifications

Name	Characteristic	0–66 MHz		Unit
		Min	Max	
T1	DT0IN / DT1IN / DT2IN / DT3IN cycle time	3	—	t <sub>CYC</sub>
T2	DT0IN / DT1IN / DT2IN / DT3IN pulse width	1	—	t <sub>CYC</sub>

## 6.12 QSPI Electrical Specifications

Table 42 lists QSPI timings.

Table 42. QSPI Modules AC Timing Specifications

Name	Characteristic	Min	Max	Unit
QS1	QSPI_CS[1:0] to QSPI_CLK	1	510	tcyc
QS2	QSPI_CLK high to QSPI_DOUT valid.	—	10	ns
QS3	QSPI_CLK high to QSPI_DOUT invalid. (Output hold)	2	—	ns
QS4	QSPI_DIN to QSPI_CLK (Input setup)	9	—	ns
QS5	QSPI_DIN to QSPI_CLK (Input hold)	9	—	ns

The values in Table 42 correspond to Figure 23.

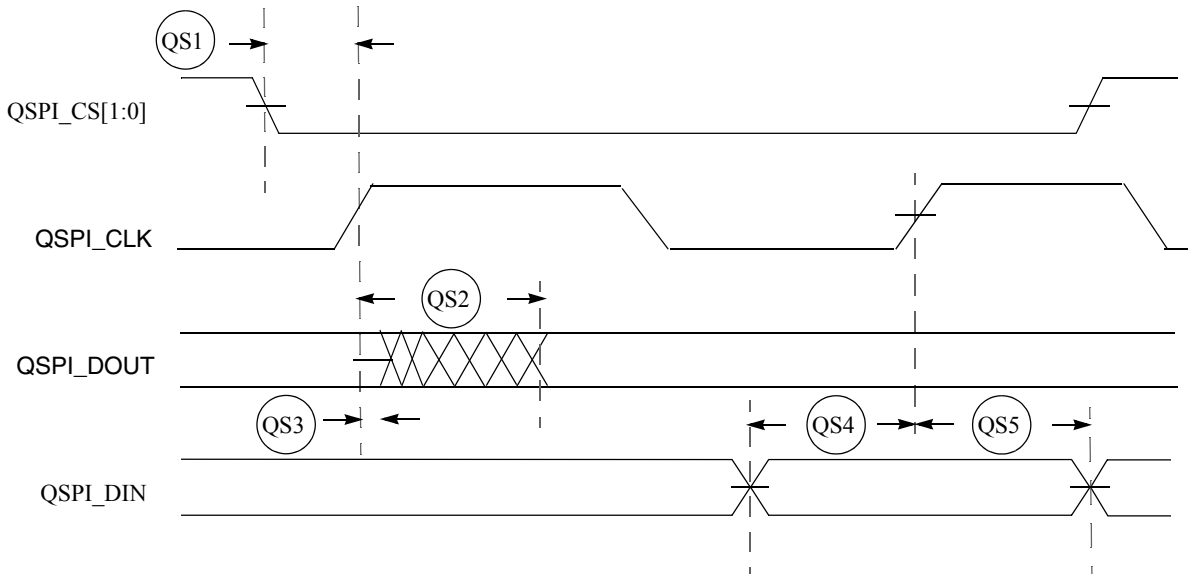

Figure 23. QSPI Timing

## 6.13 JTAG and Boundary Scan Timing

Table 43. JTAG and Boundary Scan Timing

Num	Characteristics <sup>1</sup>	Symbol	Min	Max	Unit
J1	TCLK Frequency of Operation	$f_{JCYC}$	DC	1/4	$f_{sys/2}$
J2	TCLK Cycle Period	$t_{JCYC}$	4	-	$t_{CYC}$
J3	TCLK Clock Pulse Width	$t_{JCW}$	26	-	ns
J4	TCLK Rise and Fall Times	$t_{JCRF}$	0	3	ns
J5	Boundary Scan Input Data Setup Time to TCLK Rise	$t_{BSDST}$	4	-	ns
J6	Boundary Scan Input Data Hold Time after TCLK Rise	$t_{BSDHT}$	26	-	ns
J7	TCLK Low to Boundary Scan Output Data Valid	$t_{BSDV}$	0	33	ns
J8	TCLK Low to Boundary Scan Output High Z	$t_{BSDZ}$	0	33	ns
J9	TMS, TDI Input Data Setup Time to TCLK Rise	$t_{TAPBST}$	4	-	ns
J10	TMS, TDI Input Data Hold Time after TCLK Rise	$t_{TAPBHT}$	10	-	ns
J11	TCLK Low to TDO Data Valid	$t_{TDODV}$	0	26	ns
J12	TCLK Low to TDO High Z	$t_{TDODZ}$	0	8	ns
J13	$\overline{TRST}$ Assert Time	$t_{TRSTAT}$	100	-	ns
J14	$\overline{TRST}$ Setup Time (Negation) to TCLK High	$t_{TRSTST}$	10	-	ns

NOTES:

<sup>1</sup> JTAG\_EN is expected to be a static signal. Hence, specific timing is not associated with it.

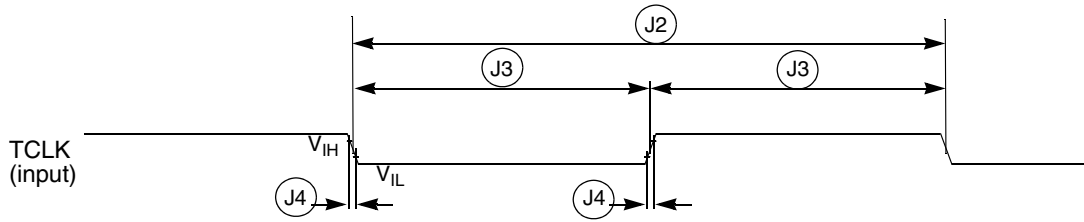

Figure 24. Test Clock Input Timing

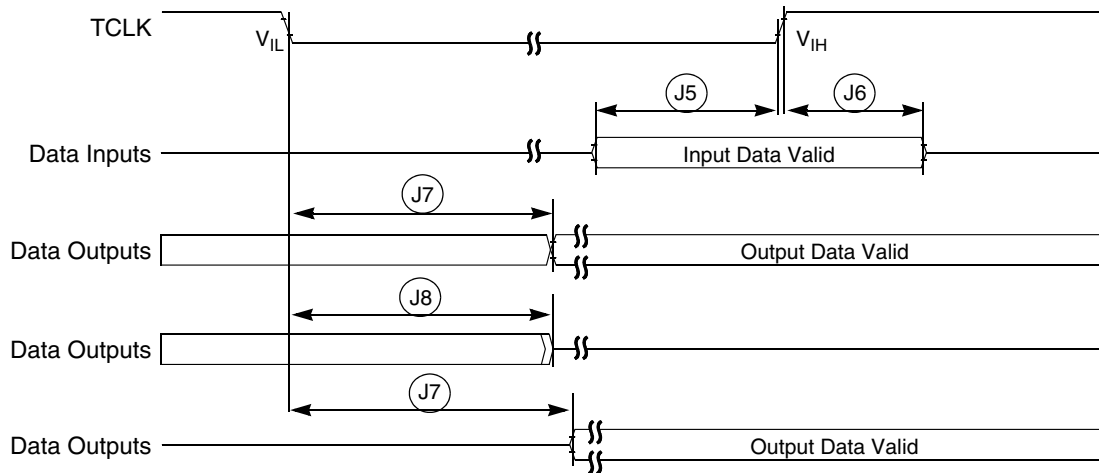

Figure 25. Boundary Scan (JTAG) Timing

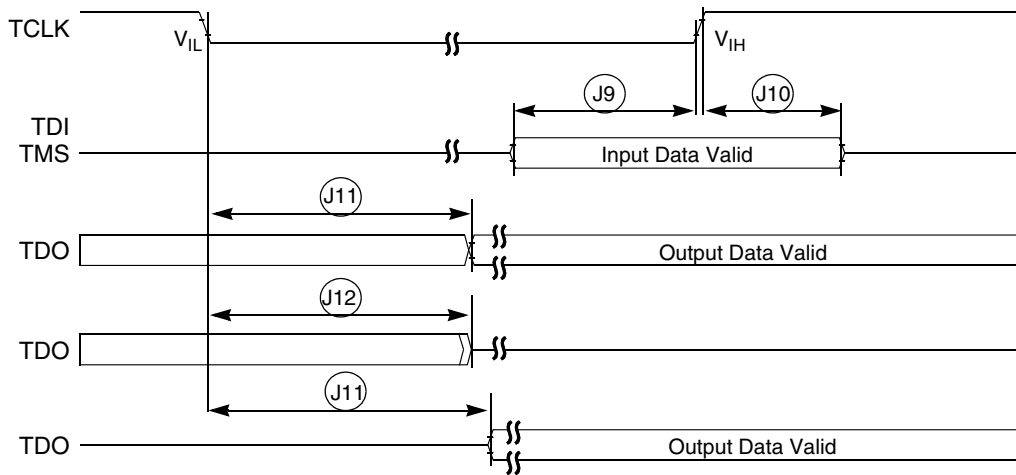

Figure 26. Test Access Port Timing

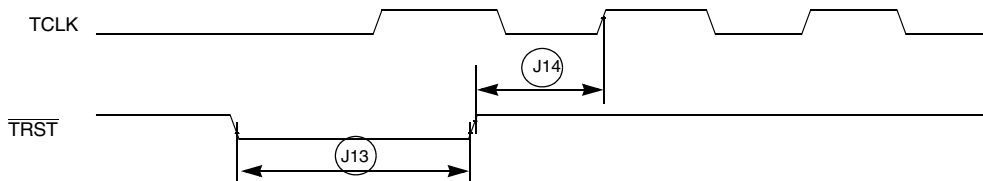

Figure 27. TRST Timing

## 6.14 Debug AC Timing Specifications

Table 44 lists specifications for the debug AC timing parameters shown in Figure 29.

Table 44. Debug AC Timing Specification

Num	Characteristic	150 MHz		Units
		Min	Max	
DE0	PSTCLK cycle time		0.5	$t_{cyc}$
DE1	PST valid to PSTCLK high	4		ns
DE2	PSTCLK high to PST invalid	1.5		ns
DE3	DSCLK cycle time	5		$t_{cyc}$
DE4	DSI valid to DSCLK high	1		$t_{cyc}$



**Table 44. Debug AC Timing Specification**

Num	Characteristic	150 MHz		Units
		Min	Max	
DE5 <sup>1</sup>	DSCLK high to DSO invalid	4		t <sub>cyc</sub>
DE6	$\overline{\text{BKPT}}$ input data setup time to CLKOUT Rise	4		ns
DE7	CLKOUT high to $\overline{\text{BKPT}}$ high Z	0	10	ns

NOTES:

<sup>1</sup> DSCLK and DSI are synchronized internally. D4 is measured from the synchronized DSCLK input relative to the rising edge of CLKOUT.

Figure 28 shows real-time trace timing for the values in Table 44.

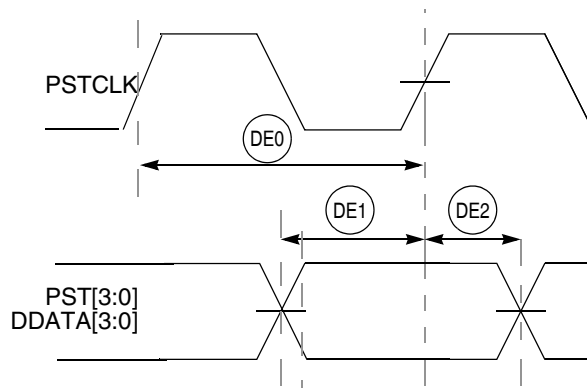

**Figure 28. Real-Time Trace AC Timing**

Figure 29 shows BDM serial port AC timing for the values in Table 44.

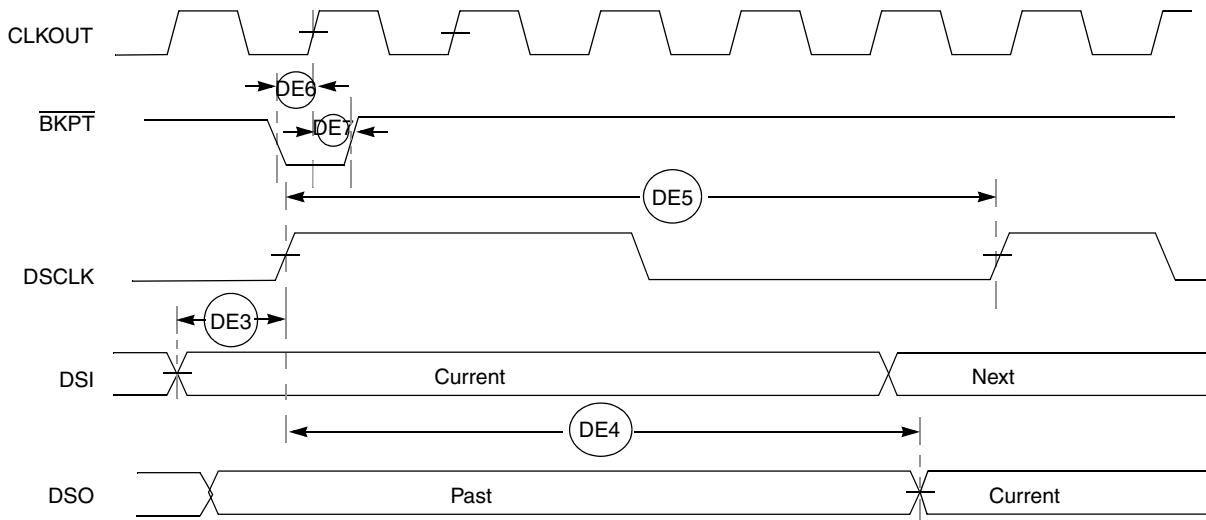

**Figure 29. BDM Serial Port AC Timing**

## 7 Documentation

Table 46 lists the documents that provide a complete description of the MCF523x and their development support tools. Documentation is available from a local Freescale distributor, a Freescale semiconductor sales office, the Freescale Literature Distribution Center, or through the Freescale world-wide web address at <http://www.freescale.com>.

**Table 45. MCF523x Documentation**

Freescale Document Number	Title	Revision	Status
MCF5235EC	MCF5235 RISC Microprocessor Hardware Specifications	Rev. 1.3	This document
MCF5235RM	MCF523x Reference Manual	1	Available
MCF5235PB	MCF523x Product Brief	0	Available
MCF523xFS	MCF523x Fact Sheet	—	In Process
eTPURM/D	eTPU User Manual	0	Available
CFPRODFACT/D	The ColdFire Family of 32-Bit Microprocessors Family Overview and Technology Roadmap	0	Available under NDA
MCF5xxxWP	MCF5xxxWP WHITE PAPER: Motorola ColdFire VL RISC Processors	0	Available under NDA
MAPBGAPP	MAPBGA 4-Layer Example	0	Available
CFPRM/D	ColdFire Family Programmer's Reference Manual	2	Available

### 7.1 Document Revision History

Table 46 provides a revision history for this document.

**Table 46. Document Revision History**

Rev. No.	Substantive Change(s)
0	Preliminary release.
1	-Updated Signal List table
1.1	-Removed duplicate information in the module description sections. The information is all in the Signals Description Table.
1.2	-Corrected Figure 8 pin 81. VDD instead of VSS -Changed instances of Motorola to Freescale
1.3	-Removed detailed signal description section. This information can be found in the MCF5235RM Chapter 2. -Removed detailed feature list. This information can be found in the MCF5235RM Chapter 1. -Corrected Figure 2 pin F10. VSS instead of VDD. Change made in Table 2 as well. -Corrected Figure 8 pin 81. OVDD instead of VDD. Change made in Table 2 as well. -Cleaned up many inconsistencies within the pinout figure signal names -Corrected document IDs in Table 45

**THIS PAGE INTENTIONALLY LEFT BLANK**

## **HOW TO REACH US:**

### **USA/Europe/Locations not listed:**

Freescale Semiconductor Literature Distribution  
P.O. Box 5405, Denver, Colorado 80217  
1-800-521-6274 or 480-768-2130

### **Japan:**

Freescale Semiconductor Japan Ltd.  
Technical Information Center  
3-20-1, Minami-Azabu, Minato-ku  
Tokyo 106-8573, Japan  
81-3-3440-3569

### **Asia/Pacific:**

Freescale Semiconductor H.K. Ltd.  
2 Dai King Street  
Tai Po Industrial Estate  
Tai Po, N.T. Hong Kong  
852-26668334

### *Learn More:*

For more information about Freescale Semiconductor products, please visit <http://www.freescale.com>

Information in this document is provided solely to enable system and software implementers to use Freescale Semiconductor products. There are no express or implied copyright licenses granted hereunder to design or fabricate any integrated circuits or integrated circuits based on the information in this document.

Freescale Semiconductor reserves the right to make changes without further notice to any products herein. Freescale Semiconductor makes no warranty, representation or guarantee regarding the suitability of its products for any particular purpose, nor does Freescale Semiconductor assume any liability arising out of the application or use of any product or circuit, and specifically disclaims any and all liability, including without limitation consequential or incidental damages. "Typical" parameters which may be provided in Freescale Semiconductor data sheets and/or specifications can and do vary in different applications and actual performance may vary over time. All operating parameters, including "Typicals" must be validated for each customer application by customer's technical experts. Freescale Semiconductor does not convey any license under its patent rights nor the rights of others. Freescale Semiconductor products are not designed, intended, or authorized for use as components in systems intended for surgical implant into the body, or other applications intended to support or sustain life, or for any other application in which the failure of the Freescale Semiconductor product could create a situation where personal injury or death may occur. Should Buyer purchase or use Freescale Semiconductor products for any such unintended or unauthorized application, Buyer shall indemnify and hold Freescale Semiconductor and its officers, employees, subsidiaries, affiliates, and distributors harmless against all claims, costs, damages, and expenses, and reasonable attorney fees arising out of, directly or indirectly, any claim of personal injury or death associated with such unintended or unauthorized use, even if such claim alleges that Freescale Semiconductor was negligent regarding the design or manufacture of the part.

Freescale™ and the Freescale logo are trademarks of Freescale Semiconductor, Inc. All other product or service names are the property of their respective owners.  
© Freescale Semiconductor, Inc. 2004.