



# M93C86, M93C76, M93C66 M93C56, M93C46

16Kbit, 8Kbit, 4Kbit, 2Kbit and 1Kbit (8-bit or 16-bit wide)  
MICROWIRE® Serial Access EEPROM

## FEATURES SUMMARY

- Industry Standard MICROWIRE Bus
- Single Supply Voltage:
  - 4.5 to 5.5V for M93Cx6
  - 2.5 to 5.5V for M93Cx6-W
  - 1.8 to 5.5V for M93Cx6-R
- Dual Organization: by Word (x16) or Byte (x8)
- Programming Instructions that work on: Byte, Word or Entire Memory
- Self-timed Programming Cycle with Auto-Erase
- Ready/Busy Signal During Programming
- Speed:
  - 1MHz Clock Rate, 10ms Write Time (Current product, identified by process identification letter F or M)
  - 2MHz Clock Rate, 5ms Write Time (New Product, identified by process identification letter W or G or S)
- Sequential Read Operation
- Enhanced ESD/Latch-Up Behaviour
- More than 1 Million Erase/Write Cycles
- More than 40 Year Data Retention

Table 1. Product List

Reference	Part Number	Reference	Part Number
M93C86	M93C86	M93C56	M93C56
	M93C86-W		M93C56-W
	M93C86-R		M93C56-R
M93C76	M93C76	M93C46	M93C46
	M93C76-W		M93C46-W
	M93C76-R		M93C46-R
M93C66	M93C66		
	M93C66-W		
	M93C66-R		

Figure 1. Packages

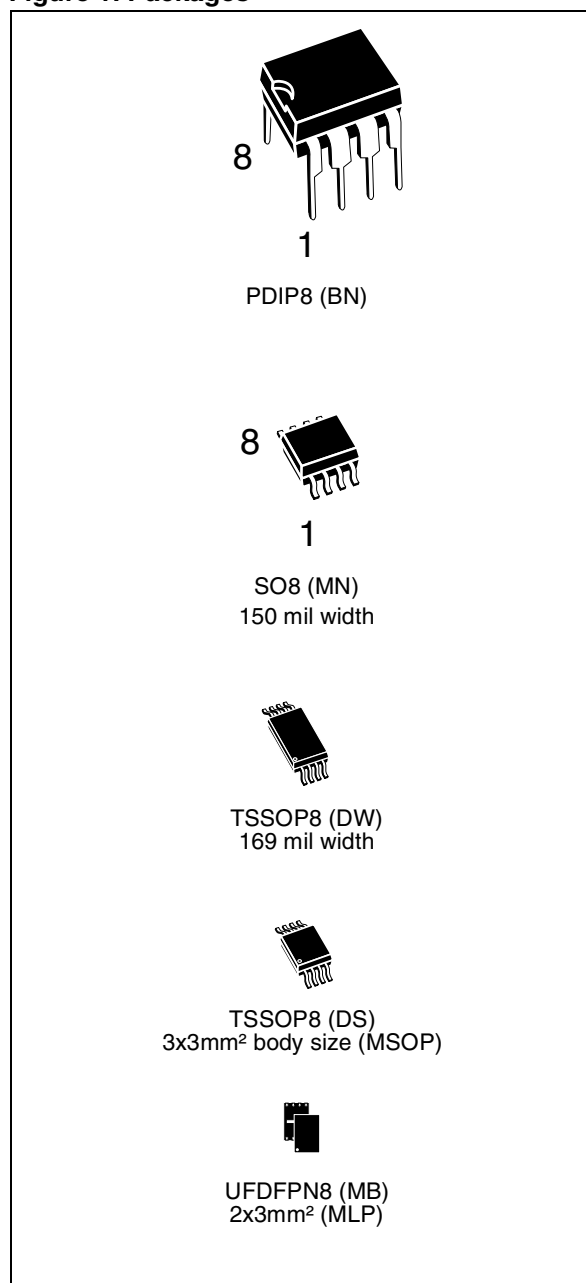

## TABLE OF CONTENTS

<b>FEATURES SUMMARY</b> .....	<b>1</b>
Table 1. Product List .....	1
Figure 1. Packages .....	1
Figure 2. Logic Diagram .....	4
Table 2. Signal Names .....	4
Table 3. Memory Size versus Organization .....	4
Table 4. Instruction Set for the M93Cx6 .....	4
Figure 3. DIP, SO, TSSOP and MLP Connections (Top View) .....	5
<b>MEMORY ORGANIZATION</b> .....	<b>5</b>
<b>POWER-ON DATA PROTECTION</b> .....	<b>5</b>
<b>INSTRUCTIONS</b> .....	<b>6</b>
Table 5. Instruction Set for the M93C46 .....	6
Table 6. Instruction Set for the M93C56 and M93C66 .....	7
Table 7. Instruction Set for the M93C76 and M93C86 .....	7
<b>Read</b> .....	<b>8</b>
<b>Erase/Write Enable and Disable</b> .....	<b>8</b>
Figure 4. READ, WRITE, EWEN, EWDS Sequences .....	8
<b>Erase</b> .....	<b>9</b>
<b>Write</b> .....	<b>9</b>
Figure 5. ERASE, ERAL Sequences .....	9
<b>Erase All</b> .....	<b>10</b>
<b>Write All</b> .....	<b>10</b>
Figure 6. WRAL Sequence .....	10
<b>READY/BUSY STATUS</b> .....	<b>11</b>
<b>COMMON I/O OPERATION</b> .....	<b>11</b>
<b>CLOCK PULSE COUNTER</b> .....	<b>11</b>
Figure 7. Write Sequence with One Clock Glitch .....	11
<b>MAXIMUM RATING</b> .....	<b>12</b>
Table 8. Absolute Maximum Ratings .....	12
<b>DC AND AC PARAMETERS</b> .....	<b>13</b>
Table 9. Operating Conditions (M93Cx6) .....	13
Table 10. Operating Conditions (M93Cx6-W) .....	13
Table 11. Operating Conditions (M93Cx6-R) .....	13
Table 12. AC Measurement Conditions (M93Cx6) .....	14
Table 13. AC Measurement Conditions (M93Cx6-W and M93Cx6-R) .....	14
Figure 8. AC Testing Input Output Waveforms .....	14

Table 14. Capacitance . . . . .	14
Table 15. DC Characteristics (M93Cx6, Device Grade 6) . . . . .	15
Table 16. DC Characteristics (M93Cx6, Device Grade 7 or 3) . . . . .	15
Table 17. DC Characteristics (M93Cx6-W, Device Grade 6) . . . . .	16
Table 18. DC Characteristics (M93Cx6-W, Device Grade 7 or 3) . . . . .	17
Table 19. DC Characteristics (M93Cx6-R) . . . . .	17
Table 20. AC Characteristics (M93Cx6, Device Grade 6, 7 or 3) . . . . .	18
Table 21. AC Characteristics (M93Cx6-W, Device Grade 6) . . . . .	19
Table 22. AC Characteristics (M93Cx6-W, Device Grade 7 or 3) . . . . .	20
Table 23. AC Characteristics (M93Cx6-R) . . . . .	21
Figure 9. Synchronous Timing (Start and Op-Code Input) . . . . .	22
Figure 10. Synchronous Timing (Read or Write) . . . . .	22
Figure 11. Synchronous Timing (Read or Write) . . . . .	22
<b>PACKAGE MECHANICAL . . . . .</b>	<b>23</b>
Figure 12. PDIP8 – 8 pin Plastic DIP, 0.25mm lead frame, Package Outline . . . . .	23
Table 24. PDIP8 – 8 pin Plastic DIP, 0.25mm lead frame, Package Mechanical Data . . . . .	23
Figure 13. SO8 narrow – 8 lead Plastic Small Outline, 150 mils body width, Package Outline . . . . .	24
Table 25. SO8 narrow – 8 lead Plastic Small Outline, 150 mils body width, Package Mechanical Data . . . . .	24
Figure 14. UDFPN8 (MLP8) 8-lead Ultra thin Fine pitch Dual Flat Package No lead 2x3mm <sup>2</sup> , Outline . . . . .	25
Table 26. UDFPN8 (MLP8) 8-lead Ultra thin Fine pitch Dual Flat Package No lead 2x3mm <sup>2</sup> , Data . . . . .	25
Figure 15. TSSOP8 3x3mm <sup>2</sup> – 8 lead Thin Shrink Small Outline, 3x3mm <sup>2</sup> body size, Package Outline . . . . .	26
Table 27. TSSOP8 3x3mm <sup>2</sup> – 8 lead Thin Shrink Small Outline, 3x3mm <sup>2</sup> body size, Mechanical Data . . . . .	26
Figure 16. TSSOP8 – 8 lead Thin Shrink Small Outline, Package Outline . . . . .	27
Table 28. TSSOP8 – 8 lead Thin Shrink Small Outline, Package Mechanical Data . . . . .	27
<b>PART NUMBERING . . . . .</b>	<b>28</b>
Table 29. Ordering Information Scheme . . . . .	28
Table 30. How to Identify Current and New Products by the Process Identification Letter . . . . .	29
<b>REVISION HISTORY . . . . .</b>	<b>30</b>
Table 31. Document Revision History . . . . .	30

## SUMMARY DESCRIPTION

These electrically erasable programmable memory (EEPROM) devices are accessed through a Serial Data Input (D) and Serial Data Output (Q) using the MICROWIRE bus protocol.

Figure 2. Logic Diagram

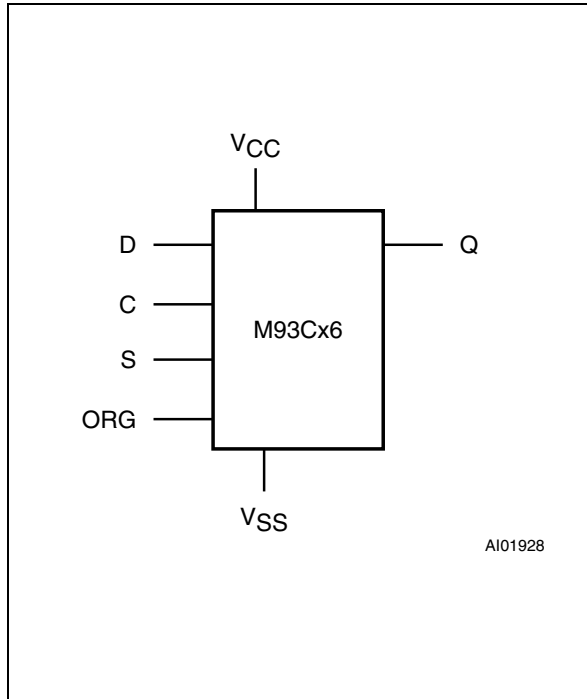

Table 2. Signal Names

S	Chip Select Input
D	Serial Data Input
Q	Serial Data Output
C	Serial Clock
ORG	Organisation Select
V <sub>CC</sub>	Supply Voltage
V <sub>SS</sub>	Ground

The memory array organization may be divided into either bytes (x8) or words (x16) which may be selected by a signal applied on Organization Select (ORG). The bit, byte and word sizes of the memories are as shown in [Table 3.](#)

Table 3. Memory Size versus Organization

Device	Number of Bits	Number of 8-bit Bytes	Number of 16-bit Words
M93C86	16384	2048	1024
M93C76	8192	1024	512
M93C66	4096	512	256
M93C56	2048	256	128
M93C46	1024	128	64

The M93Cx6 is accessed by a set of instructions, as summarized in [Table 4.](#), and in more detail in [Table 5.](#) to [Table 7.](#)

Table 4. Instruction Set for the M93Cx6

Instruction	Description	Data
READ	Read Data from Memory	Byte or Word
WRITE	Write Data to Memory	Byte or Word
EWEN	Erase/Write Enable	
EWDS	Erase/Write Disable	
ERASE	Erase Byte or Word	Byte or Word
ERAL	Erase All Memory	
WRAL	Write All Memory with same Data	

A Read Data from Memory (READ) instruction loads the address of the first byte or word to be read in an internal address register. The data at this address is then clocked out serially. The address register is automatically incremented after the data is output and, if Chip Select Input (S) is held High, the M93Cx6 can output a sequential stream of data bytes or words. In this way, the memory can be read as a data stream from eight to 16384 bits long (in the case of the M93C86), or continuously (the address counter automatically rolls over to 00h when the highest address is reached).

Programming is internally self-timed (the external clock signal on Serial Clock (C) may be stopped or left running after the start of a Write cycle) and does not require an Erase cycle prior to the Write instruction. The Write instruction writes 8 or 16 bits at a time into one of the byte or word locations of the M93Cx6. After the start of the programming cycle, a Busy/Ready signal is available on Serial Data Output (Q) when Chip Select Input (S) is driven High.

An internal Power-on Data Protection mechanism in the M93Cx6 inhibits the device when the supply is too low.

**Figure 3. DIP, SO, TSSOP and MLP Connections (Top View)**

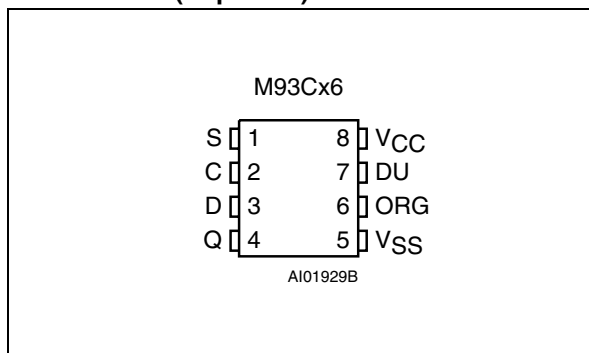

Note: 1. See [PACKAGE MECHANICAL](#) section for package dimensions, and how to identify pin-1.  
2. DU = Don't Use.

The DU (Don't Use) pin does not contribute to the normal operation of the device. It is reserved for use by STMicroelectronics during test sequences. The pin may be left unconnected or may be connected to V<sub>CC</sub> or V<sub>SS</sub>. Direct connection of DU to V<sub>SS</sub> is recommended for the lowest stand-by power consumption.

## MEMORY ORGANIZATION

The M93Cx6 memory is organized either as bytes (x8) or as words (x16). If Organization Select (ORG) is left unconnected (or connected to V<sub>CC</sub>) the x16 organization is selected; when Organization Select (ORG) is connected to Ground (V<sub>SS</sub>) the x8 organization is selected. When the M93Cx6 is in stand-by mode, Organization Select (ORG) should be set either to V<sub>SS</sub> or V<sub>CC</sub> for minimum power consumption. Any voltage between V<sub>SS</sub> and V<sub>CC</sub> applied to Organization Select (ORG) may increase the stand-by current.

## POWER-ON DATA PROTECTION

To prevent data corruption and inadvertent write operations during power-up, a Power-On Reset (POR) circuit resets all internal programming circuitry, and sets the device in the Write Disable mode.

- At Power-up and Power-down, the device must *not* be selected (that is, Chip Select Input (S) must be driven Low) until the supply voltage reaches the operating value V<sub>CC</sub> specified in [Table 9](#). to [Table 11](#).
- When V<sub>CC</sub> reaches its valid level, the device is properly reset (in the Write Disable mode) and is ready to decode and execute incoming instructions.

For the M93Cx6 devices (5V range) the POR threshold voltage is around 3V. For the M93Cx6-W (3V range) and M93Cx6-R (2V range) the POR threshold voltage is around 1.5V.

## INSTRUCTIONS

The instruction set of the M93Cx6 devices contains seven instructions, as summarized in [Table 5.](#) to [Table 7.](#) Each instruction consists of the following parts, as shown in [Figure 4.](#):

- Each instruction is preceded by a rising edge on Chip Select Input (S) with Serial Clock (C) being held Low.
- A start bit, which is the first '1' read on Serial Data Input (D) during the rising edge of Serial Clock (C).
- Two op-code bits, read on Serial Data Input (D) during the rising edge of Serial Clock (C). (Some instructions also use the first two bits of the address to define the op-code).

- The address bits of the byte or word that is to be accessed. For the M93C46, the address is made up of 6 bits for the x16 organization or 7 bits for the x8 organization (see [Table 5.](#)). For the M93C56 and M93C66, the address is made up of 8 bits for the x16 organization or 9 bits for the x8 organization (see [Table 6.](#)). For the M93C76 and M93C86, the address is made up of 10 bits for the x16 organization or 11 bits for the x8 organization (see [Table 7.](#)).

The M93Cx6 devices are fabricated in CMOS technology and are therefore able to run as slow as 0 Hz (static input signals) or as fast as the maximum ratings specified in [Table 20.](#) to [Table 23.](#)

**Table 5. Instruction Set for the M93C46**

Instruc tion	Description	Start bit	Op- Code	x8 Origination (ORG = 0)			x16 Origination (ORG = 1)		
				Address <sup>1</sup>	Data	Required Clock Cycles	Address <sup>1</sup>	Data	Required Clock Cycles
READ	Read Data from Memory	1	10	A6-A0	Q7-Q0		A5-A0	Q15-Q0	
WRITE	Write Data to Memory	1	01	A6-A0	D7-D0	18	A5-A0	D15-D0	25
EWEN	Erase/Write Enable	1	00	11X XXXX		10	11 XXXX		9
EWDS	Erase/Write Disable	1	00	00X XXXX		10	00 XXXX		9
ERASE	Erase Byte or Word	1	11	A6-A0		10	A5-A0		9
ERAL	Erase All Memory	1	00	10X XXXX		10	10 XXXX		9
WRAL	Write All Memory with same Data	1	00	01X XXXX	D7-D0	18	01 XXXX	D15-D0	25

Note: 1. X = Don't Care bit.

Table 6. Instruction Set for the M93C56 and M93C66

Instruction	Description	Start bit	Op-Code	x8 Origination (ORG = 0)			x16 Origination (ORG = 1)		
				Address <sup>1,2</sup>	Data	Required Clock Cycles	Address <sup>1,3</sup>	Data	Required Clock Cycles
READ	Read Data from Memory	1	10	A8-A0	Q7-Q0		A7-A0	Q15-Q0	
WRITE	Write Data to Memory	1	01	A8-A0	D7-D0	20	A7-A0	D15-D0	27
EWEN	Erase/Write Enable	1	00	1 1XXX XXXX		12	11XX XXXX		11
EWDS	Erase/Write Disable	1	00	0 0XXX XXXX		12	00XX XXXX		11
ERASE	Erase Byte or Word	1	11	A8-A0		12	A7-A0		11
ERAL	Erase All Memory	1	00	1 0XXX XXXX		12	10XX XXXX		11
WRAL	Write All Memory with same Data	1	00	0 1XXX XXXX	D7-D0	20	01XX XXXX	D15-D0	27

Note: 1. X = Don't Care bit.

2. Address bit A8 is not decoded by the M93C56.

3. Address bit A7 is not decoded by the M93C56.

Table 7. Instruction Set for the M93C76 and M93C86

Instruction	Description	Start bit	Op-Code	x8 Origination (ORG = 0)			x16 Origination (ORG = 1)		
				Address <sup>1,2</sup>	Data	Required Clock Cycles	Address <sup>1,3</sup>	Data	Required Clock Cycles
READ	Read Data from Memory	1	10	A10-A0	Q7-Q0		A9-A0	Q15-Q0	
WRITE	Write Data to Memory	1	01	A10-A0	D7-D0	22	A9-A0	D15-D0	29
EWEN	Erase/Write Enable	1	00	11X XXXX XXXX		14	11 XXXX XXXX		13
EWDS	Erase/Write Disable	1	00	00X XXXX XXXX		14	00 XXXX XXXX		13
ERASE	Erase Byte or Word	1	11	A10-A0		14	A9-A0		13
ERAL	Erase All Memory	1	00	10X XXXX XXXX		14	10 XXXX XXXX		13
WRAL	Write All Memory with same Data	1	00	01X XXXX XXXX	D7-D0	22	01 XXXX XXXX	D15-D0	29

Note: 1. X = Don't Care bit.

2. Address bit A10 is not decoded by the M93C76.

3. Address bit A9 is not decoded by the M93C76.

**Read**

The Read Data from Memory (READ) instruction outputs data on Serial Data Output (Q). When the instruction is received, the op-code and address are decoded, and the data from the memory is transferred to an output shift register. A dummy 0 bit is output first, followed by the 8-bit byte or 16-bit word, with the most significant bit first. Output data changes are triggered by the rising edge of Serial Clock (C). The M93Cx6 automatically increments the internal address register and clocks out the next byte (or word) as long as the Chip Select Input (S) is held High. In this case, the dummy 0 bit is *not* output between bytes (or words) and a continuous stream of data can be read.

**Erase/Write Enable and Disable**

The Erase/Write Enable (EWEN) instruction enables the future execution of erase or write instructions, and the Erase/Write Disable (EWDS) instruction disables it. When power is first applied, the M93Cx6 initializes itself so that erase and write instructions are disabled. After an Erase/Write Enable (EWEN) instruction has been executed, erasing and writing remains enabled until an Erase/Write Disable (EWDS) instruction is executed, or until V<sub>CC</sub> falls below the power-on reset threshold voltage. To protect the memory contents from accidental corruption, it is advisable to issue the Erase/Write Disable (EWDS) instruction after every write cycle. The Read Data from Memory (READ) instruction is not affected by the Erase/Write Enable (EWEN) or Erase/Write Disable (EWDS) instructions.

**Figure 4. READ, WRITE, EWEN, EWDS Sequences**

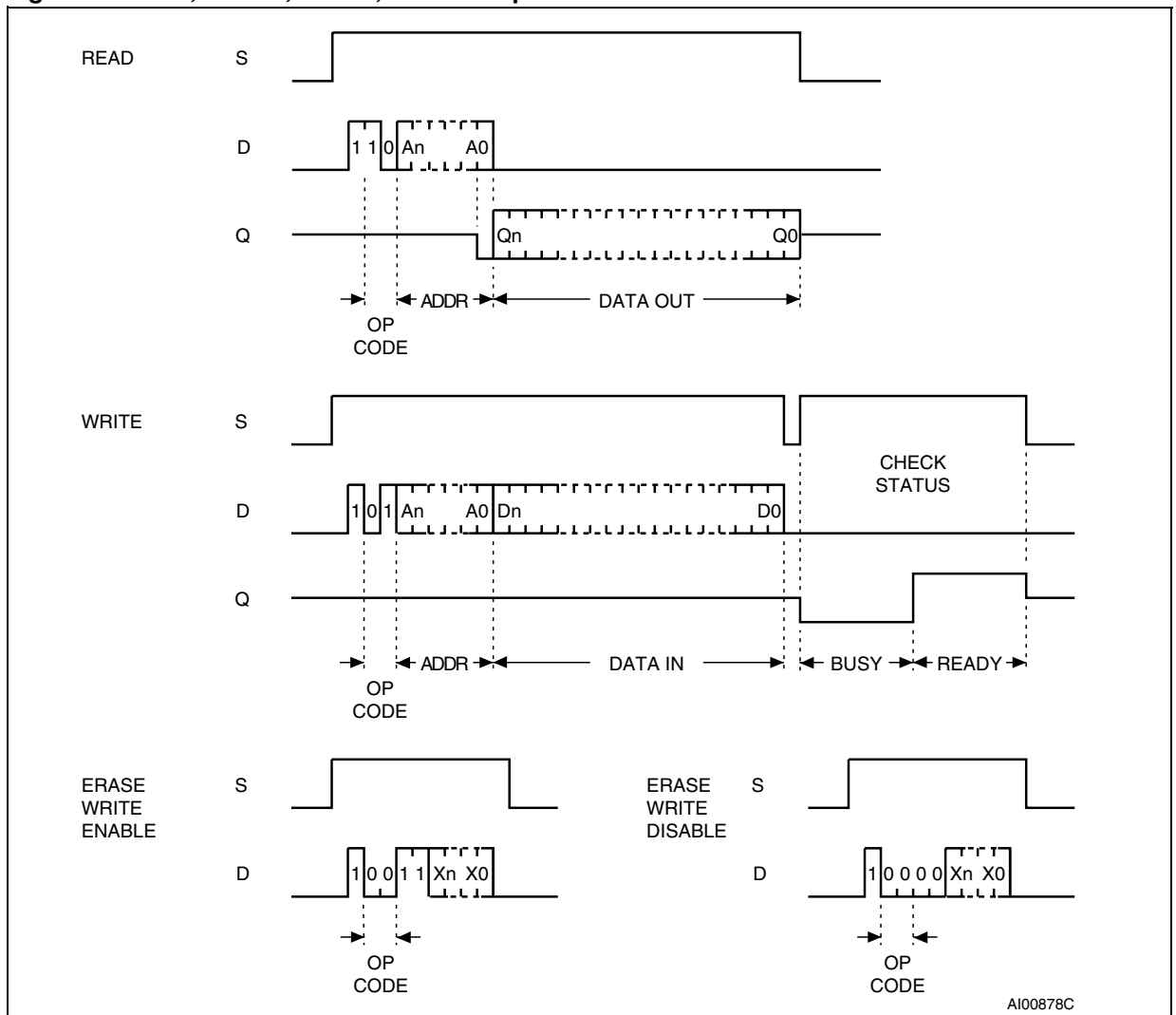

Note: For the meanings of An, Xn, Qn and Dn, see Table 5., Table 6. and Table 7..



## Erase

The Erase Byte or Word (ERASE) instruction sets the bits of the addressed memory byte (or word) to 1. Once the address has been correctly decoded, the falling edge of the Chip Select Input (S) starts the self-timed Erase cycle. The completion of the cycle can be detected by monitoring the Ready/Busy line, as described in the [READY/BUSY STATUS](#) section.

## Write

For the Write Data to Memory (WRITE) instruction, 8 or 16 data bits follow the op-code and address bits. These form the byte or word that is to be written. As with the other bits, Serial Data Input (D) is sampled on the rising edge of Serial Clock (C).

After the last data bit has been sampled, the *Chip Select Input (S) must be taken Low before the next rising edge of Serial Clock (C)*. If Chip Select Input (S) is brought Low before or after this specific time frame, the self-timed programming cycle will not be started, and the addressed location will not be programmed. The completion of the cycle can be detected by monitoring the Ready/Busy line, as described later in this document.

Once the Write cycle has been started, it is internally self-timed (the external clock signal on Serial Clock (C) may be stopped or left running after the start of a Write cycle). The cycle is automatically preceded by an Erase cycle, so it is unnecessary to execute an explicit erase instruction before a Write Data to Memory (WRITE) instruction.

**Figure 5. ERASE, ERAL Sequences**

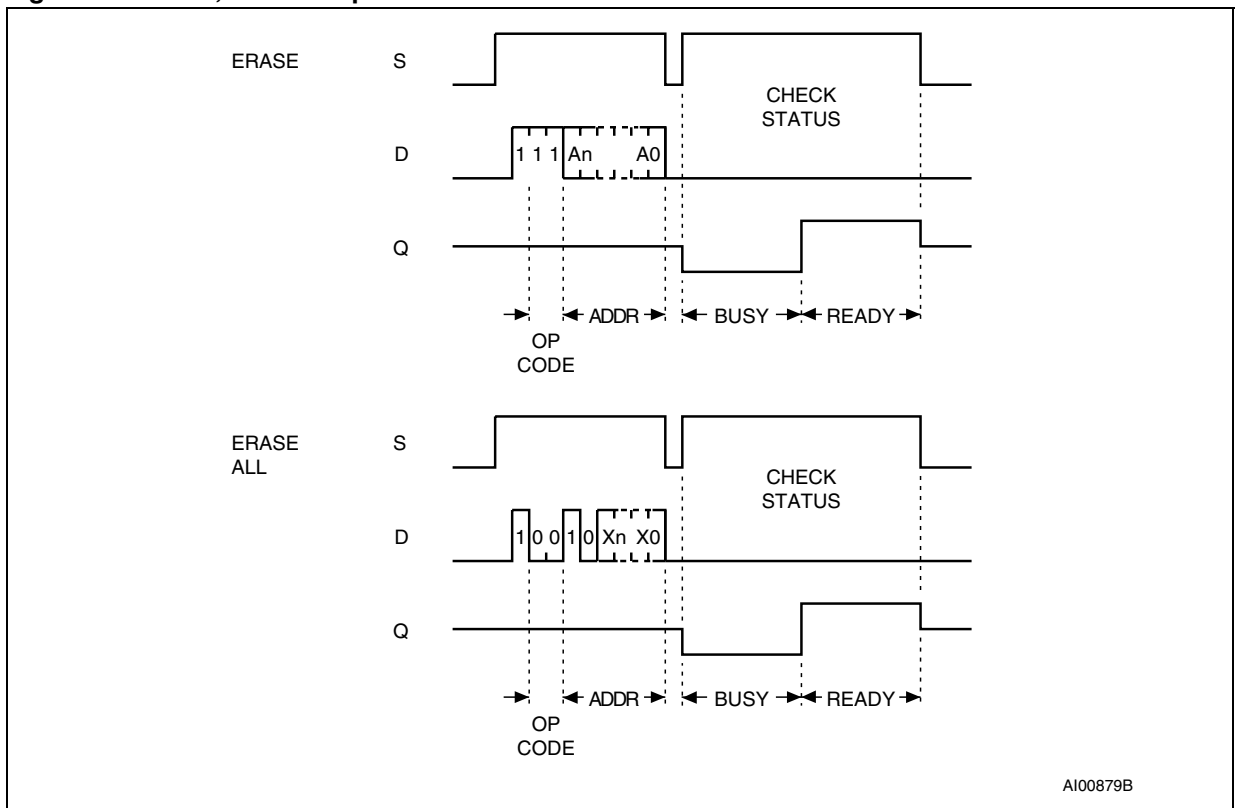

Note: For the meanings of An and Xn, please see [Table 5.](#), [Table 6.](#) and [Table 7.](#)

**Erase All**

The Erase All Memory (ERAL) instruction erases the whole memory (all memory bits are set to 1). The format of the instruction requires that a dummy address be provided. The Erase cycle is conducted in the same way as the Erase instruction (ERASE). The completion of the cycle can be detected by monitoring the Ready/Busy line, as described in the [READY/BUSY STATUS](#) section.

**Write All**

As with the Erase All Memory (ERAL) instruction, the format of the Write All Memory with same Data (WRAL) instruction requires that a dummy address be provided. As with the Write Data to Memory (WRITE) instruction, the format of the Write All Memory with same Data (WRAL) instruction requires that an 8-bit data byte, or 16-bit data word, be provided. This value is written to all the addresses of the memory device. The completion of the cycle can be detected by monitoring the Ready/Busy line, as described next.

**Figure 6. WRAL Sequence**

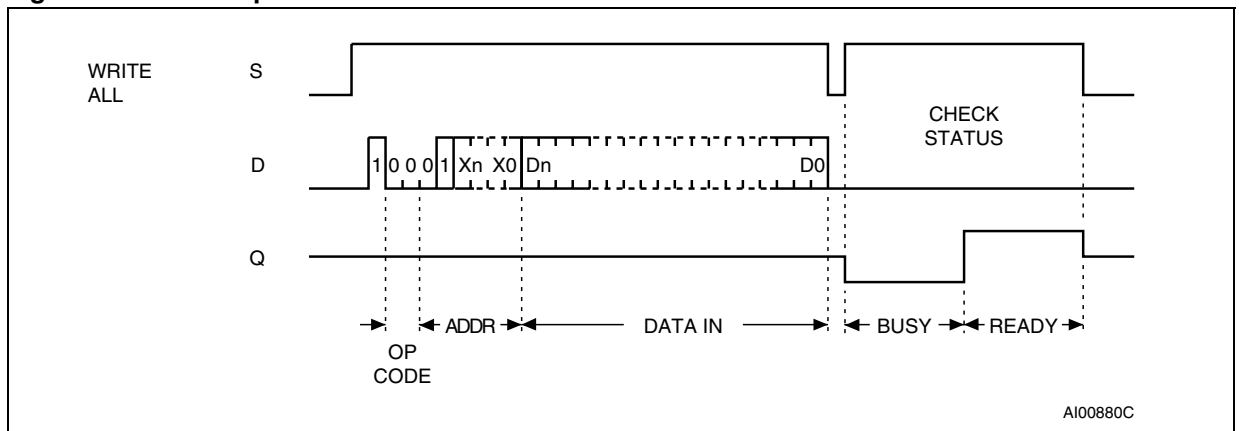

Note: For the meanings of Xn and Dn, please see [Table 5.](#), [Table 6.](#) and [Table 7.](#)

## READY/BUSY STATUS

While the Write or Erase cycle is underway, for a WRITE, ERASE, WRAL or ERAL instruction, the Busy signal ( $Q=0$ ) is returned whenever Chip Select Input (S) is driven High. (Please note, though, that there is an initial delay, of  $t_{SLSH}$ , before this status information becomes available). In this state, the M93Cx6 ignores any data on the bus. When the Write cycle is completed, and Chip Select Input (S) is driven High, the Ready signal ( $Q=1$ ) indicates that the M93Cx6 is ready to receive the next instruction. Serial Data Output (Q) remains set to 1 until the Chip Select Input (S) is brought Low or until a new start bit is decoded.

## COMMON I/O OPERATION

Serial Data Output (Q) and Serial Data Input (D) can be connected together, through a current limiting resistor, to form a common, single-wire data bus. Some precautions must be taken when operating the memory in this way, mostly to prevent a short circuit current from flowing when the last address bit (A0) clashes with the first data bit on Serial Data Output (Q). Please see the application note AN394 for details.

## CLOCK PULSE COUNTER

In a noisy environment, the number of pulses received on Serial Clock (C) may be greater than the number delivered by the master (the microcontroller). This can lead to a misalignment of the instruction of one or more bits (as shown in Figure 7.) and may lead to the writing of erroneous data at an erroneous address.

To combat this problem, the M93Cx6 has an on-chip counter that counts the clock pulses from the start bit until the falling edge of the Chip Select Input (S). If the number of clock pulses received is not the number expected, the WRITE, ERASE, ERAL or WRAL instruction is aborted, and the contents of the memory are not modified.

The number of clock cycles expected for each instruction, and for each member of the M93Cx6 family, are summarized in Table 5. to Table 7.. For example, a Write Data to Memory (WRITE) instruction on the M93C56 (or M93C66) expects 20 clock cycles (for the x8 organization) from the start bit to the falling edge of Chip Select Input (S). That is:

- 1 Start bit
- + 2 Op-code bits
- + 9 Address bits
- + 8 Data bits

Figure 7. Write Sequence with One Clock Glitch

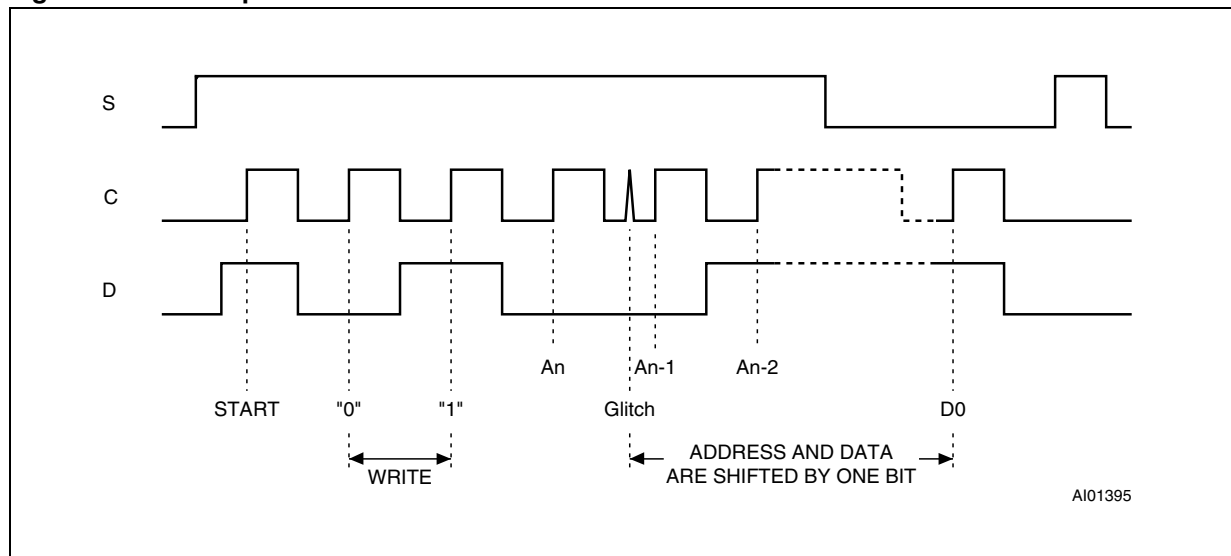

## MAXIMUM RATING

Stressing the device above the rating listed in the "Absolute Maximum Ratings" table may cause permanent damage to the device. These are stress ratings only and operation of the device at these or any other conditions above those indicated in the Operating sections of this specification is not im-

plied. Exposure to Absolute Maximum Rating conditions for extended periods may affect device reliability. Refer also to the STMicroelectronics SURE Program and other relevant quality documents.

**Table 8. Absolute Maximum Ratings**

Symbol	Parameter	Min.	Max.	Unit
T <sub>STG</sub>	Storage Temperature	-65	150	°C
T <sub>LEAD</sub>	Lead Temperature during Soldering	See note <sup>1</sup>		°C
V <sub>OUT</sub>	Output range (Q = V <sub>OH</sub> or Hi-Z)	-0.50	V <sub>CC</sub> +0.5	V
V <sub>IN</sub>	Input range	-0.50	V <sub>CC</sub> +1	V
V <sub>CC</sub>	Supply Voltage	-0.50	6.5	V
V <sub>ESD</sub>	Electrostatic Discharge Voltage (Human Body model) <sup>2</sup>	-4000	4000	V

Note: 1. Compliant with JEDEC Std J-STD-020B (for small body, Sn-Pb or Pb assembly), the ST ECOPACK® 7191395 specification, and the European directive on Restrictions on Hazardous Substances (RoHS) 2002/95/EU

2. JEDEC Std JESD22-A114A (C1=100 pF, R1=1500 Ω, R2=500 Ω)

## DC AND AC PARAMETERS

This section summarizes the operating and measurement conditions, and the DC and AC characteristics of the device. The parameters in the DC and AC Characteristic tables that follow are derived from tests performed under the Measure-

ment Conditions summarized in the relevant tables. Designers should check that the operating conditions in their circuit match the measurement conditions when relying on the quoted parameters.

**Table 9. Operating Conditions (M93Cx6)**

Symbol	Parameter	Min.	Max.	Unit
V <sub>CC</sub>	Supply Voltage	4.5	5.5	V
T <sub>A</sub>	Ambient Operating Temperature (Device Grade 6)	-40	85	°C
	Ambient Operating Temperature (Device Grade 7)	-40	105	°C
	Ambient Operating Temperature (Device Grade 3)	-40	125	°C

**Table 10. Operating Conditions (M93Cx6-W)**

Symbol	Parameter	Min.	Max.	Unit
V <sub>CC</sub>	Supply Voltage	2.5	5.5	V
T <sub>A</sub>	Ambient Operating Temperature (Device Grade 6)	-40	85	°C
	Ambient Operating Temperature (Device Grade 7)	-40	105	°C
	Ambient Operating Temperature (Device Grade 3)	-40	125	°C

**Table 11. Operating Conditions (M93Cx6-R)**

Symbol	Parameter	Min.	Max.	Unit
V <sub>CC</sub>	Supply Voltage	1.8	5.5	V
T <sub>A</sub>	Ambient Operating Temperature (Device Grade 6)	-40	85	°C

**Table 12. AC Measurement Conditions (M93Cx6)**

Symbol	Parameter	Min.	Max.	Unit
$C_L$	Load Capacitance	100		pF
	Input Rise and Fall Times		50	ns
	Input Pulse Voltages	0.4 V to 2.4 V		V
	Input Timing Reference Voltages	1.0 V and 2.0 V		V
	Output Timing Reference Voltages	0.8 V and 2.0 V		V

Note: 1. Output Hi-Z is defined as the point where data out is no longer driven.

**Table 13. AC Measurement Conditions (M93Cx6-W and M93Cx6-R)**

Symbol	Parameter	Min.	Max.	Unit
$C_L$	Load Capacitance	100		pF
	Input Rise and Fall Times		50	ns
	Input Pulse Voltages	0.2V <sub>CC</sub> to 0.8V <sub>CC</sub>		V
	Input Timing Reference Voltages	0.3V <sub>CC</sub> to 0.7V <sub>CC</sub>		V
	Output Timing Reference Voltages	0.3V <sub>CC</sub> to 0.7V <sub>CC</sub>		V

Note: 1. Output Hi-Z is defined as the point where data out is no longer driven.

**Figure 8. AC Testing Input Output Waveforms**

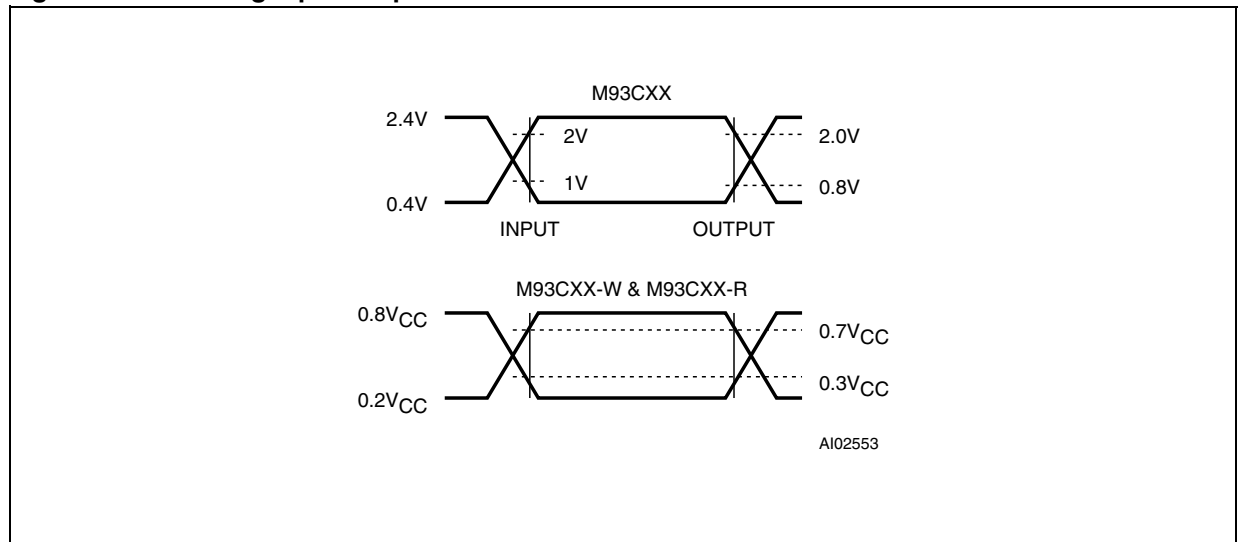

**Table 14. Capacitance**

Symbol	Parameter	Test Condition	Min	Max	Unit
$C_{OUT}$	Output Capacitance	$V_{OUT} = 0V$		5	pF
$C_{IN}$	Input Capacitance	$V_{IN} = 0V$		5	pF

Note: Sampled only, not 100% tested, at  $T_A=25^\circ C$  and a frequency of 1MHz.

Table 15. DC Characteristics (M93Cx6, Device Grade 6)

Symbol	Parameter	Test Condition	Min.	Max.	Unit
$I_{LI}$	Input Leakage Current	$0V \leq V_{IN} \leq V_{CC}$		$\pm 2.5$	$\mu A$
$I_{LO}$	Output Leakage Current	$0V \leq V_{OUT} \leq V_{CC}$ , Q in Hi-Z		$\pm 2.5$	$\mu A$
$I_{CC}$	Supply Current	$V_{CC} = 5V$ , $S = V_{IH}$ , $f = 1$ MHz, Current Product <sup>1</sup>		1.5	mA
		$V_{CC} = 5V$ , $S = V_{IH}$ , $f = 2$ MHz, New Product <sup>2</sup>		2	mA
$I_{CC1}$	Supply Current (Stand-by)	$V_{CC} = 5V$ , $S = V_{SS}$ , $C = V_{SS}$ , ORG = $V_{SS}$ or $V_{CC}$ , Current Product <sup>1</sup>		50	$\mu A$
		$V_{CC} = 5V$ , $S = V_{SS}$ , $C = V_{SS}$ , ORG = $V_{SS}$ or $V_{CC}$ , New Product <sup>2</sup>		15	$\mu A$
$V_{IL}$	Input Low Voltage	$V_{CC} = 5V \pm 10\%$	-0.45	0.8	V
$V_{IH}$	Input High Voltage	$V_{CC} = 5V \pm 10\%$	2	$V_{CC} + 1$	V
$V_{OL}$	Output Low Voltage	$V_{CC} = 5V$ , $I_{OL} = 2.1$ mA		0.4	V
$V_{OH}$	Output High Voltage	$V_{CC} = 5V$ , $I_{OH} = -400\mu A$	2.4		V

Note: 1. Current product: identified by Process Identification letter F or M.

2. New product: identified by Process Identification letter W or G or S.

Table 16. DC Characteristics (M93Cx6, Device Grade 7 or 3)

Symbol	Parameter	Test Condition	Min.	Max.	Unit
$I_{LI}$	Input Leakage Current	$0V \leq V_{IN} \leq V_{CC}$		$\pm 2.5$	$\mu A$
$I_{LO}$	Output Leakage Current	$0V \leq V_{OUT} \leq V_{CC}$ , Q in Hi-Z		$\pm 2.5$	$\mu A$
$I_{CC}$	Supply Current	$V_{CC} = 5V$ , $S = V_{IH}$ , $f = 1$ MHz, Current Product <sup>1</sup>		1.5	mA
		$V_{CC} = 5V$ , $S = V_{IH}$ , $f = 2$ MHz, New Product <sup>2</sup>		2	mA
$I_{CC1}$	Supply Current (Stand-by)	$V_{CC} = 5V$ , $S = V_{SS}$ , $C = V_{SS}$ , ORG = $V_{SS}$ or $V_{CC}$ , Current Product <sup>1</sup>		50	$\mu A$
		$V_{CC} = 5V$ , $S = V_{SS}$ , $C = V_{SS}$ , ORG = $V_{SS}$ or $V_{CC}$ , New Product <sup>2</sup>		15	$\mu A$
$V_{IL}$	Input Low Voltage	$V_{CC} = 5V \pm 10\%$	-0.45	0.8	V
$V_{IH}$	Input High Voltage	$V_{CC} = 5V \pm 10\%$	2	$V_{CC} + 1$	V
$V_{OL}$	Output Low Voltage	$V_{CC} = 5V$ , $I_{OL} = 2.1$ mA		0.4	V
$V_{OH}$	Output High Voltage	$V_{CC} = 5V$ , $I_{OH} = -400\mu A$	2.4		V

Note: 1. Current product: identified by Process Identification letter F or M.

2. New product: identified by Process Identification letter W or G or S.

**Table 17. DC Characteristics (M93Cx6-W, Device Grade 6)**

Symbol	Parameter	Test Condition	Min.	Max.	Unit
$I_{LI}$	Input Leakage Current	$0V \leq V_{IN} \leq V_{CC}$		$\pm 2.5$	$\mu A$
$I_{LO}$	Output Leakage Current	$0V \leq V_{OUT} \leq V_{CC}$ , Q in Hi-Z		$\pm 2.5$	$\mu A$
$I_{CC}$	Supply Current (CMOS Inputs)	$V_{CC} = 5V$ , $S = V_{IH}$ , $f = 1$ MHz, Current Product <sup>1</sup>		1.5	mA
		$V_{CC} = 2.5V$ , $S = V_{IH}$ , $f = 1$ MHz, Current Product <sup>1</sup>		1	mA
		$V_{CC} = 5V$ , $S = V_{IH}$ , $f = 2$ MHz, New Product <sup>2</sup>		2	mA
		$V_{CC} = 2.5V$ , $S = V_{IH}$ , $f = 2$ MHz, New Product <sup>2</sup>		1	mA
$I_{CC1}$	Supply Current (Stand-by)	$V_{CC} = 2.5V$ , $S = V_{SS}$ , $C = V_{SS}$ , ORG = $V_{SS}$ or $V_{CC}$ , Current Product <sup>1</sup>		10	$\mu A$
		$V_{CC} = 2.5V$ , $S = V_{SS}$ , $C = V_{SS}$ , ORG = $V_{SS}$ or $V_{CC}$ , New Product <sup>2</sup>		5	$\mu A$
$V_{IL}$	Input Low Voltage (D, C, S)		-0.45	$0.2 V_{CC}$	V
$V_{IH}$	Input High Voltage (D, C, S)		$0.7 V_{CC}$	$V_{CC} + 1$	V
$V_{OL}$	Output Low Voltage (Q)	$V_{CC} = 5V$ , $I_{OL} = 2.1$ mA		0.4	V
		$V_{CC} = 2.5V$ , $I_{OL} = 100$ $\mu A$		0.2	V
$V_{OH}$	Output High Voltage (Q)	$V_{CC} = 5V$ , $I_{OH} = -400$ $\mu A$	2.4		V
		$V_{CC} = 2.5V$ , $I_{OH} = -100$ $\mu A$	$V_{CC} - 0.2$		V

Note: 1. Current product: identified by Process Identification letter F or M.  
 2. New product: identified by Process Identification letter W or G or S.



**Table 18. DC Characteristics (M93Cx6-W, Device Grade 7 or 3)**

Symbol	Parameter	Test Condition	Min. <sup>1</sup>	Max. <sup>1</sup>	Unit
I <sub>LI</sub>	Input Leakage Current	$0V \leq V_{IN} \leq V_{CC}$		±2.5	μA
I <sub>LO</sub>	Output Leakage Current	$0V \leq V_{OUT} \leq V_{CC}$ , Q in Hi-Z		±2.5	μA
I <sub>CC</sub>	Supply Current (CMOS Inputs)	$V_{CC} = 5V$ , S = V <sub>IH</sub> , f = 2 MHz		2	mA
		$V_{CC} = 2.5V$ , S = V <sub>IH</sub> , f = 2 MHz		1	mA
I <sub>CC1</sub>	Supply Current (Stand-by)	$V_{CC} = 2.5V$ , S = V <sub>SS</sub> , C = V <sub>SS</sub> , ORG = V <sub>SS</sub> or V <sub>CC</sub>		5	μA
V <sub>IL</sub>	Input Low Voltage (D, C, S)		-0.45	0.2 V <sub>CC</sub>	V
V <sub>IH</sub>	Input High Voltage (D, C, S)		0.7 V <sub>CC</sub>	V <sub>CC</sub> + 1	V
V <sub>OL</sub>	Output Low Voltage (Q)	$V_{CC} = 5V$ , I <sub>OL</sub> = 2.1 mA		0.4	V
		$V_{CC} = 2.5V$ , I <sub>OL</sub> = 100 μA		0.2	V
V <sub>OH</sub>	Output High Voltage (Q)	$V_{CC} = 5V$ , I <sub>OH</sub> = -400 μA	2.4		V
		$V_{CC} = 2.5V$ , I <sub>OH</sub> = -100 μA	V <sub>CC</sub> -0.2		V

Note: 1. New product: identified by Process Identification letter W or G or S.

**Table 19. DC Characteristics (M93Cx6-R)**

Symbol	Parameter	Test Condition	Min. <sup>1</sup>	Max. <sup>1</sup>	Unit
I <sub>LI</sub>	Input Leakage Current	$0V \leq V_{IN} \leq V_{CC}$		±2.5	μA
I <sub>LO</sub>	Output Leakage Current	$0V \leq V_{OUT} \leq V_{CC}$ , Q in Hi-Z		±2.5	μA
I <sub>CC</sub>	Supply Current (CMOS Inputs)	$V_{CC} = 5V$ , S = V <sub>IH</sub> , f = 2 MHz		2	mA
		$V_{CC} = 1.8V$ , S = V <sub>IH</sub> , f = 1 MHz		1	mA
I <sub>CC1</sub>	Supply Current (Stand-by)	$V_{CC} = 1.8V$ , S = V <sub>SS</sub> , C = V <sub>SS</sub> , ORG = V <sub>SS</sub> or V <sub>CC</sub>		2	μA
V <sub>IL</sub>	Input Low Voltage (D, C, S)		-0.45	0.2 V <sub>CC</sub>	V
V <sub>IH</sub>	Input High Voltage (D, C, S)		0.8 V <sub>CC</sub>	V <sub>CC</sub> + 1	V
V <sub>OL</sub>	Output Low Voltage (Q)	$V_{CC} = 1.8V$ , I <sub>OL</sub> = 100 μA		0.2	V
V <sub>OH</sub>	Output High Voltage (Q)	$V_{CC} = 1.8V$ , I <sub>OH</sub> = -100 μA	V <sub>CC</sub> -0.2		V

Note: 1. This product is under development. For more information, please contact your nearest ST sales office.

**Table 20. AC Characteristics (M93Cx6, Device Grade 6, 7 or 3)**

Test conditions specified in <a href="#">Table 12.</a> and <a href="#">Table 9.</a>							
Symbol	Alt.	Parameter	Min. <sup>3</sup>	Max. <sup>3</sup>	Min. <sup>4</sup>	Max. <sup>4</sup>	Unit
f <sub>C</sub>	f <sub>SK</sub>	Clock Frequency	D.C.	1	D.C.	2	MHz
t <sub>SLCH</sub>		Chip Select Low to Clock High	250		50		ns
t <sub>SHCH</sub>	t <sub>CSS</sub>	Chip Select Set-up Time M93C46, M93C56, M93C66	50		50		ns
		Chip Select Set-up time M93C76, M93C86	100		50		ns
t <sub>SLSH</sub> <sup>2</sup>	t <sub>CS</sub>	Chip Select Low to Chip Select High	250		200		ns
t <sub>CHCL</sub> <sup>1</sup>	t <sub>SKH</sub>	Clock High Time	250		200		ns
t <sub>CLCH</sub> <sup>1</sup>	t <sub>SKL</sub>	Clock Low Time	250		200		ns
t <sub>DVCH</sub>	t <sub>DIS</sub>	Data In Set-up Time	100		50		ns
t <sub>CHDX</sub>	t <sub>DIH</sub>	Data In Hold Time	100		50		ns
t <sub>CLSH</sub>	t <sub>SKS</sub>	Clock Set-up Time (relative to S)	100		50		ns
t <sub>CLSL</sub>	t <sub>CSH</sub>	Chip Select Hold Time	0		0		ns
t <sub>SHQV</sub>	t <sub>SV</sub>	Chip Select to Ready/Busy Status		400		200	ns
t <sub>SLQZ</sub>	t <sub>DF</sub>	Chip Select Low to Output Hi-Z		200		100	ns
t <sub>CHQL</sub>	t <sub>PD0</sub>	Delay to Output Low		400		200	ns
t <sub>CHQV</sub>	t <sub>PD1</sub>	Delay to Output Valid		400		200	ns
t <sub>W</sub>	t <sub>WP</sub>	Erase/Write Cycle time		10		5	ms

Note: 1.  $t_{CHCL} + t_{CLCH} \geq 1 / f_C$ .  
 2. Chip Select Input (S) must be brought Low for a minimum of t<sub>SLSH</sub> between consecutive instruction cycles.  
 3. Current product: identified by Process Identification letter F or M.  
 4. New product: identified by Process Identification letter W or G or S.

Table 21. AC Characteristics (M93Cx6-W, Device Grade 6)

Test conditions specified in Table 13. and Table 10.							
Symbol	Alt.	Parameter	Min. <sup>3</sup>	Max. <sup>3</sup>	Min. <sup>4</sup>	Max. <sup>4</sup>	Unit
f <sub>C</sub>	f <sub>SK</sub>	Clock Frequency	D.C.	1	D.C.	2	MHz
t <sub>SLCH</sub>		Chip Select Low to Clock High	250		50		ns
t <sub>SHCH</sub>	t <sub>CSS</sub>	Chip Select Set-up Time	100		50		ns
t <sub>SLSH</sub> <sup>2</sup>	t <sub>CS</sub>	Chip Select Low to Chip Select High	1000		200		ns
t <sub>CHCL</sub> <sup>1</sup>	t <sub>SKH</sub>	Clock High Time	350		200		ns
t <sub>CLCH</sub> <sup>1</sup>	t <sub>SKL</sub>	Clock Low Time	250		200		ns
t <sub>DVCH</sub>	t <sub>DIS</sub>	Data In Set-up Time	100		50		ns
t <sub>CHDX</sub>	t <sub>DIH</sub>	Data In Hold Time	100		50		ns
t <sub>CLSH</sub>	t <sub>SKS</sub>	Clock Set-up Time (relative to S)	100		50		ns
t <sub>CLSL</sub>	t <sub>CSH</sub>	Chip Select Hold Time	0		0		ns
t <sub>SHQV</sub>	t <sub>SV</sub>	Chip Select to Ready/Busy Status		400		200	ns
t <sub>SLQZ</sub>	t <sub>DF</sub>	Chip Select Low to Output Hi-Z		200		100	ns
t <sub>CHQL</sub>	t <sub>PD0</sub>	Delay to Output Low		400		200	ns
t <sub>CHQV</sub>	t <sub>PD1</sub>	Delay to Output Valid		400		200	ns
t <sub>W</sub>	t <sub>WP</sub>	Erase/Write Cycle time		10		5	ms

Note: 1.  $t_{CHCL} + t_{CLCH} \geq 1 / f_C$ .

2. Chip Select Input (S) must be brought Low for a minimum of t<sub>SLSH</sub> between consecutive instruction cycles.

3. Current product: identified by Process Identification letter F or M.

4. New product: identified by Process Identification letter W or G or S.

Table 22. AC Characteristics (M93Cx6-W, Device Grade 7 or 3)

Test conditions specified in Table 13. and Table 10.					
Symbol	Alt.	Parameter	Min. <sup>3</sup>	Max. <sup>3</sup>	Unit
f <sub>C</sub>	f <sub>SK</sub>	Clock Frequency	D.C.	2	MHz
t <sub>SLCH</sub>		Chip Select Low to Clock High	50		ns
t <sub>SHCH</sub>	t <sub>CSS</sub>	Chip Select Set-up Time	50		ns
t <sub>SLSH</sub> <sup>2</sup>	t <sub>CS</sub>	Chip Select Low to Chip Select High	200		ns
t <sub>CHCL</sub> <sup>1</sup>	t <sub>SKH</sub>	Clock High Time	200		ns
t <sub>CLCH</sub> <sup>1</sup>	t <sub>SKL</sub>	Clock Low Time	200		ns
t <sub>DVCH</sub>	t <sub>DIS</sub>	Data In Set-up Time	50		ns
t <sub>CHDX</sub>	t <sub>DIH</sub>	Data In Hold Time	50		ns
t <sub>CLSH</sub>	t <sub>SKS</sub>	Clock Set-up Time (relative to S)	50		ns
t <sub>CLSL</sub>	t <sub>CSH</sub>	Chip Select Hold Time	0		ns
t <sub>SHQV</sub>	t <sub>SV</sub>	Chip Select to Ready/Busy Status		200	ns
t <sub>SLQZ</sub>	t <sub>DF</sub>	Chip Select Low to Output Hi-Z		100	ns
t <sub>CHQL</sub>	t <sub>PD0</sub>	Delay to Output Low		200	ns
t <sub>CHQV</sub>	t <sub>PD1</sub>	Delay to Output Valid		200	ns
t <sub>W</sub>	t <sub>WP</sub>	Erase/Write Cycle time		5	ms

Note: 1.  $t_{CHCL} + t_{CLCH} \geq 1 / f_C$ .

2. Chip Select Input (S) must be brought Low for a minimum of t<sub>SLSH</sub> between consecutive instruction cycles.

3. New product: identified by Process Identification letter W or G or S.

Table 23. AC Characteristics (M93Cx6-R)

Test conditions specified in Table 13. and Table 11.					
Symbol	Alt.	Parameter	Min. <sup>3</sup>	Max. <sup>3</sup>	Unit
f <sub>C</sub>	f <sub>SK</sub>	Clock Frequency	D.C.	1	MHz
t <sub>SLCH</sub>		Chip Select Low to Clock High	250		ns
t <sub>SHCH</sub>	t <sub>CSS</sub>	Chip Select Set-up Time	50		ns
t <sub>SLSH</sub> <sup>2</sup>	t <sub>CS</sub>	Chip Select Low to Chip Select High	250		ns
t <sub>CHCL</sub> <sup>1</sup>	t <sub>SKH</sub>	Clock High Time	250		ns
t <sub>CLCH</sub> <sup>1</sup>	t <sub>SKL</sub>	Clock Low Time	250		ns
t <sub>DVCH</sub>	t <sub>DIS</sub>	Data In Set-up Time	100		ns
t <sub>CHDX</sub>	t <sub>DIH</sub>	Data In Hold Time	100		ns
t <sub>CLSH</sub>	t <sub>SKS</sub>	Clock Set-up Time (relative to S)	100		ns
t <sub>CLSL</sub>	t <sub>CSH</sub>	Chip Select Hold Time	0		ns
t <sub>SHQV</sub>	t <sub>SV</sub>	Chip Select to Ready/Busy Status		400	ns
t <sub>SLQZ</sub>	t <sub>DF</sub>	Chip Select Low to Output Hi-Z		200	ns
t <sub>CHQL</sub>	t <sub>PD0</sub>	Delay to Output Low		400	ns
t <sub>CHQV</sub>	t <sub>PD1</sub>	Delay to Output Valid		400	ns
t <sub>W</sub>	t <sub>WP</sub>	Erase/Write Cycle time		10	ms

Note: 1.  $t_{CHCL} + t_{CLCH} \geq 1 / f_C$ .

2. Chip Select Input (S) must be brought Low for a minimum of t<sub>SLSH</sub> between consecutive instruction cycles.

3. This product is under development. For more information, please contact your nearest ST sales office.

Figure 9. Synchronous Timing (Start and Op-Code Input)

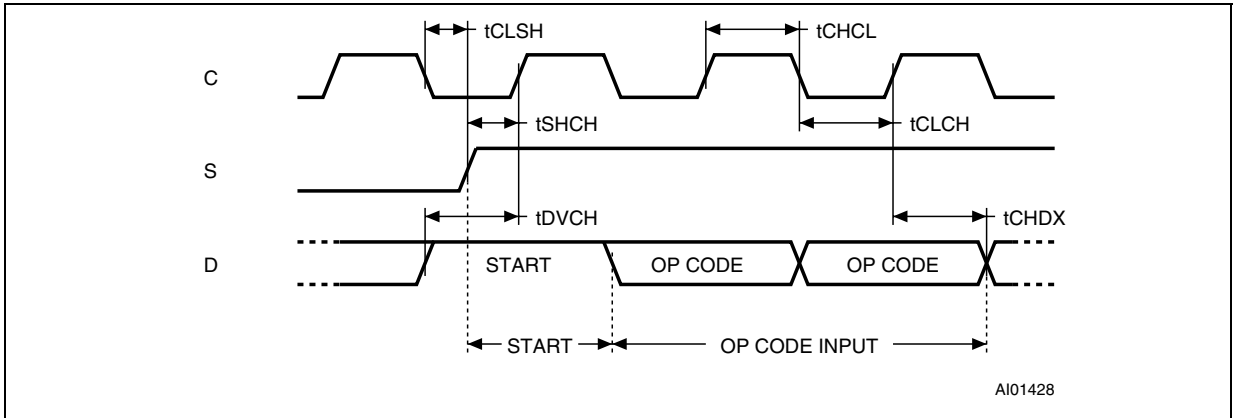

Figure 10. Synchronous Timing (Read or Write)

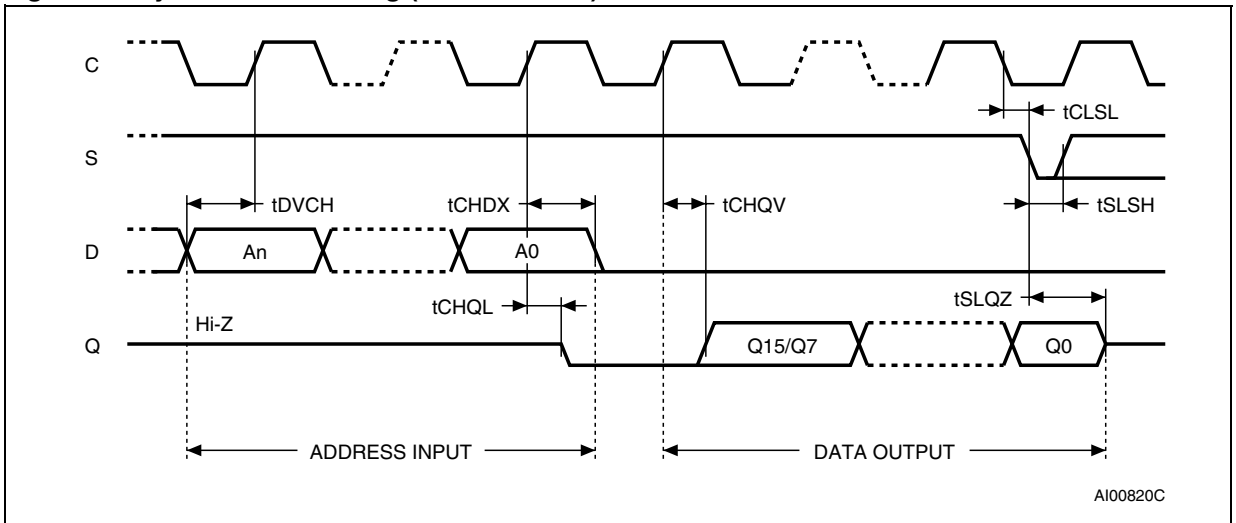
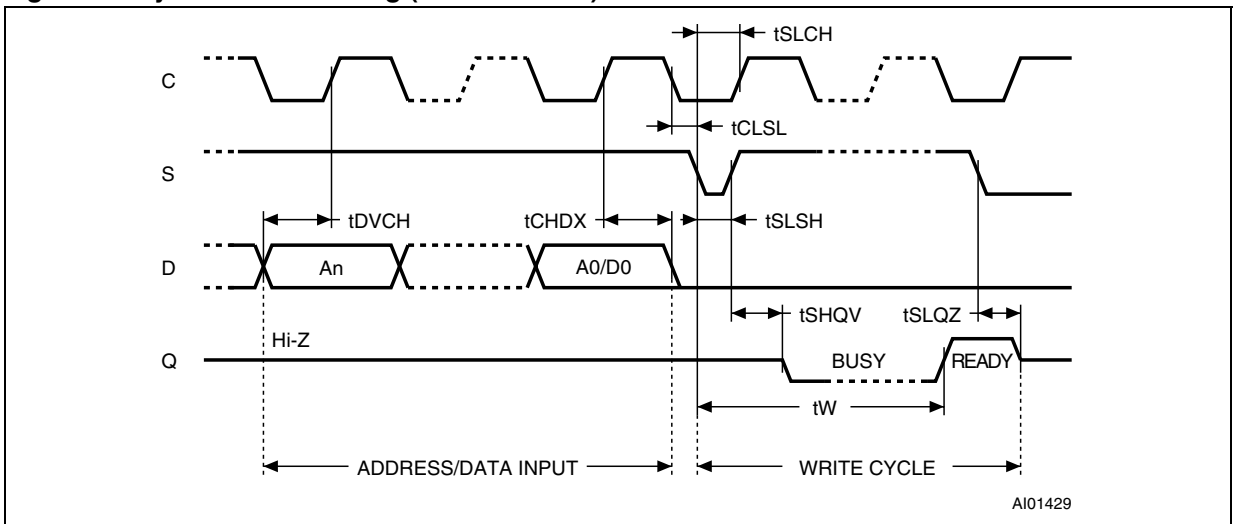
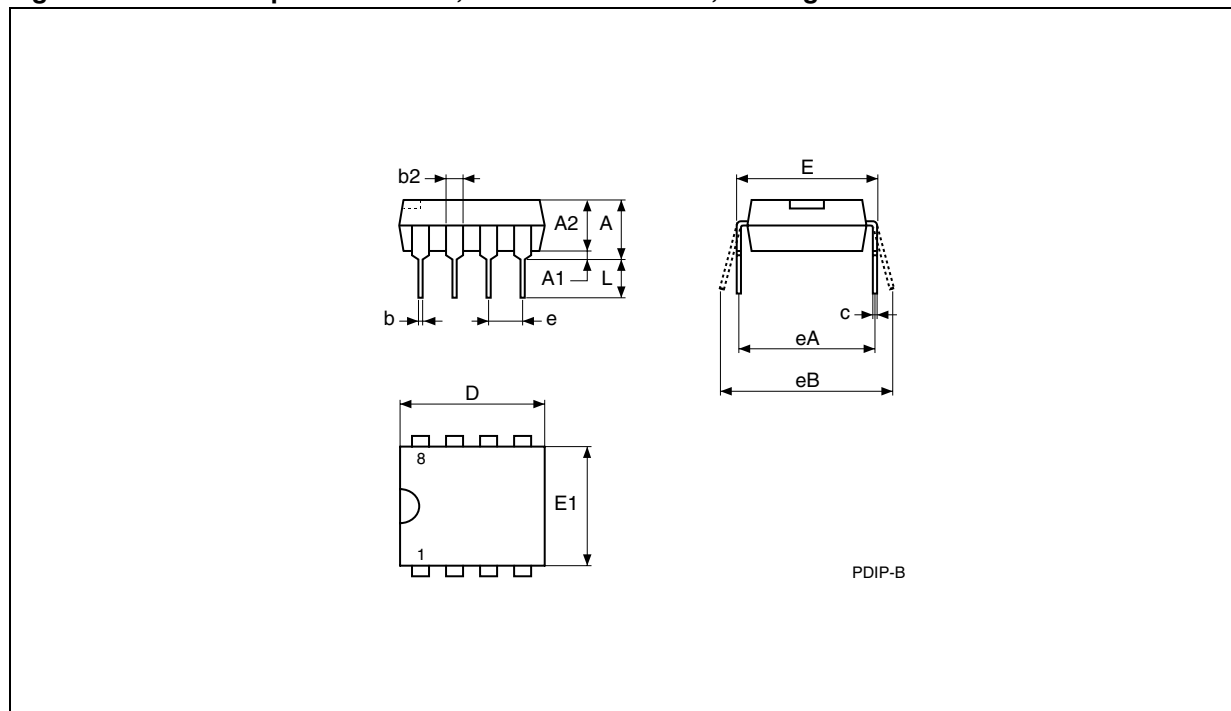

Figure 11. Synchronous Timing (Read or Write)



## PACKAGE MECHANICAL

Figure 12. PDIP8 – 8 pin Plastic DIP, 0.25mm lead frame, Package Outline



Note: Drawing is not to scale.

Table 24. PDIP8 – 8 pin Plastic DIP, 0.25mm lead frame, Package Mechanical Data

Symb.	mm			inches		
	Typ.	Min.	Max.	Typ.	Min.	Max.
A			5.33			0.210
A1		0.38			0.015	
A2	3.30	2.92	4.95	0.130	0.115	0.195
b	0.46	0.36	0.56	0.018	0.014	0.022
b2	1.52	1.14	1.78	0.060	0.045	0.070
c	0.25	0.20	0.36	0.010	0.008	0.014
D	9.27	9.02	10.16	0.365	0.355	0.400
E	7.87	7.62	8.26	0.310	0.300	0.325
E1	6.35	6.10	7.11	0.250	0.240	0.280
e	2.54	–	–	0.100	–	–
eA	7.62	–	–	0.300	–	–
eB			10.92			0.430
L	3.30	2.92	3.81	0.130	0.115	0.150

Figure 13. SO8 narrow – 8 lead Plastic Small Outline, 150 mils body width, Package Outline

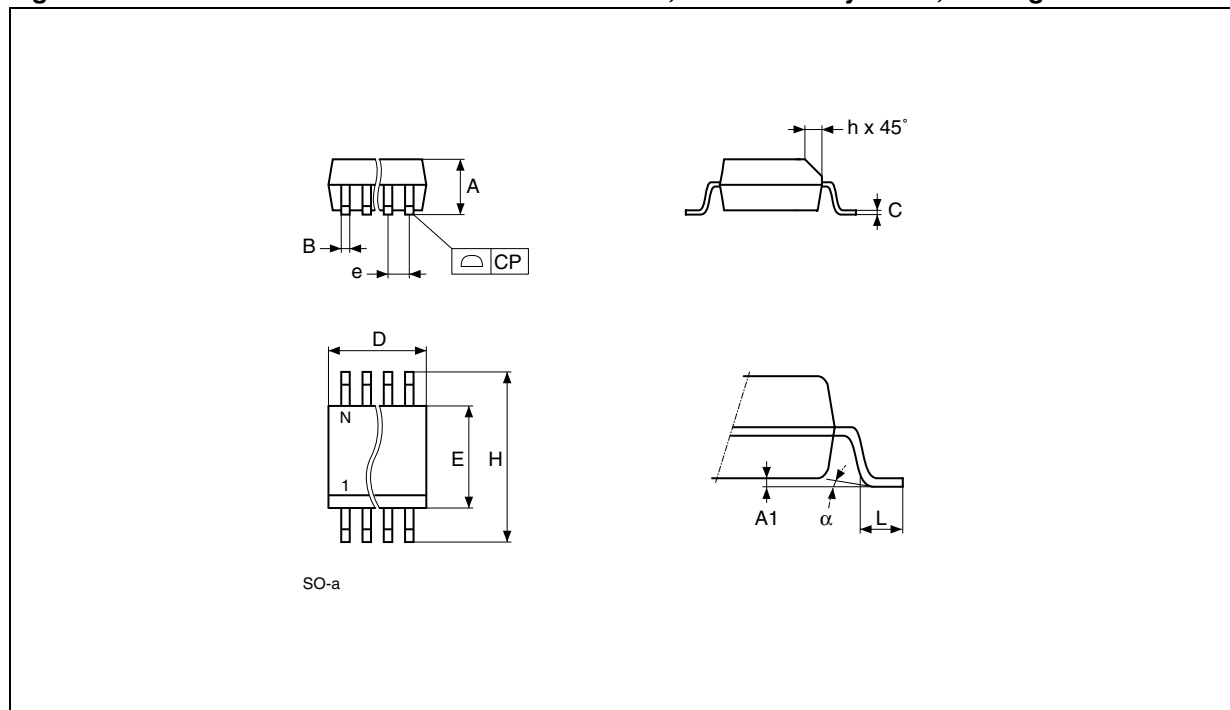

Note: Drawing is not to scale.

Table 25. SO8 narrow – 8 lead Plastic Small Outline, 150 mils body width, Package Mechanical Data

Symb.	mm			inches		
	Typ.	Min.	Max.	Typ.	Min.	Max.
A		1.35	1.75		0.053	0.069
A1		0.10	0.25		0.004	0.010
B		0.33	0.51		0.013	0.020
C		0.19	0.25		0.007	0.010
D		4.80	5.00		0.189	0.197
E		3.80	4.00		0.150	0.157
e	1.27	–	–	0.050	–	–
H		5.80	6.20		0.228	0.244
h		0.25	0.50		0.010	0.020
L		0.40	0.90		0.016	0.035
α		0°	8°		0°	8°
N		8			8	
CP			0.10			0.004

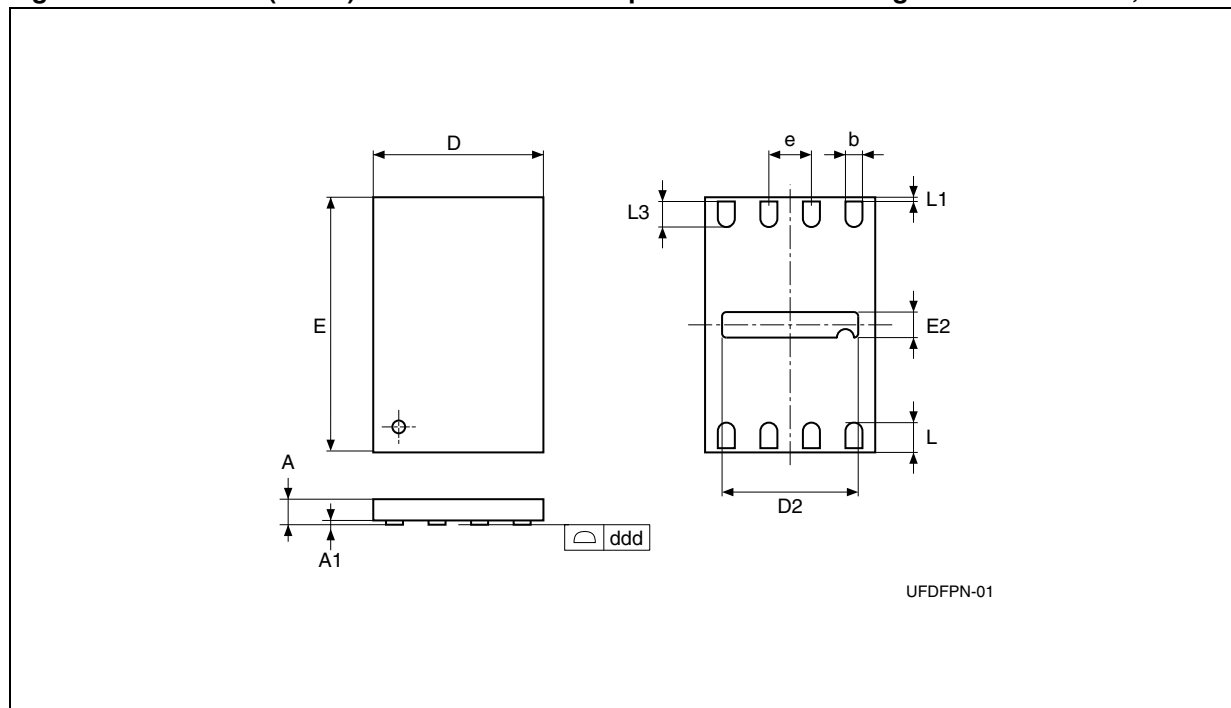

Figure 14. UFDFPN8 (MLP8) 8-lead Ultra thin Fine pitch Dual Flat Package No lead 2x3mm<sup>2</sup>, Outline

Note: 1. Drawing is not to scale.

2. The central pad (the area E2 by D2 in the above illustration) is pulled, internally, to  $V_{SS}$ . It must not be allowed to be connected to any other voltage or signal line on the PCB, for example during the soldering process.

Table 26. UFDFPN8 (MLP8) 8-lead Ultra thin Fine pitch Dual Flat Package No lead 2x3mm<sup>2</sup>, Data

Symbol	mm			inches		
	Typ.	Min.	Max.	Typ.	Min.	Max.
A	0.55	0.50	0.60	0.022	0.020	0.024
A1		0.00	0.05		0.000	0.002
b	0.25	0.20	0.30	0.010	0.008	0.012
D	2.00			0.079		
D2		1.55	1.65		0.061	0.065
ddd			0.05			0.002
E	3.00			0.118		
E2		0.15	0.25		0.006	0.010
e	0.50	–	–	0.020	–	–
L	0.45	0.40	0.50	0.018	0.016	0.020
L1			0.15			0.006
L3		0.30			0.012	
N	8			8		

Figure 15. TSSOP8 3x3mm<sup>2</sup> – 8 lead Thin Shrink Small Outline, 3x3mm<sup>2</sup> body size, Package Outline

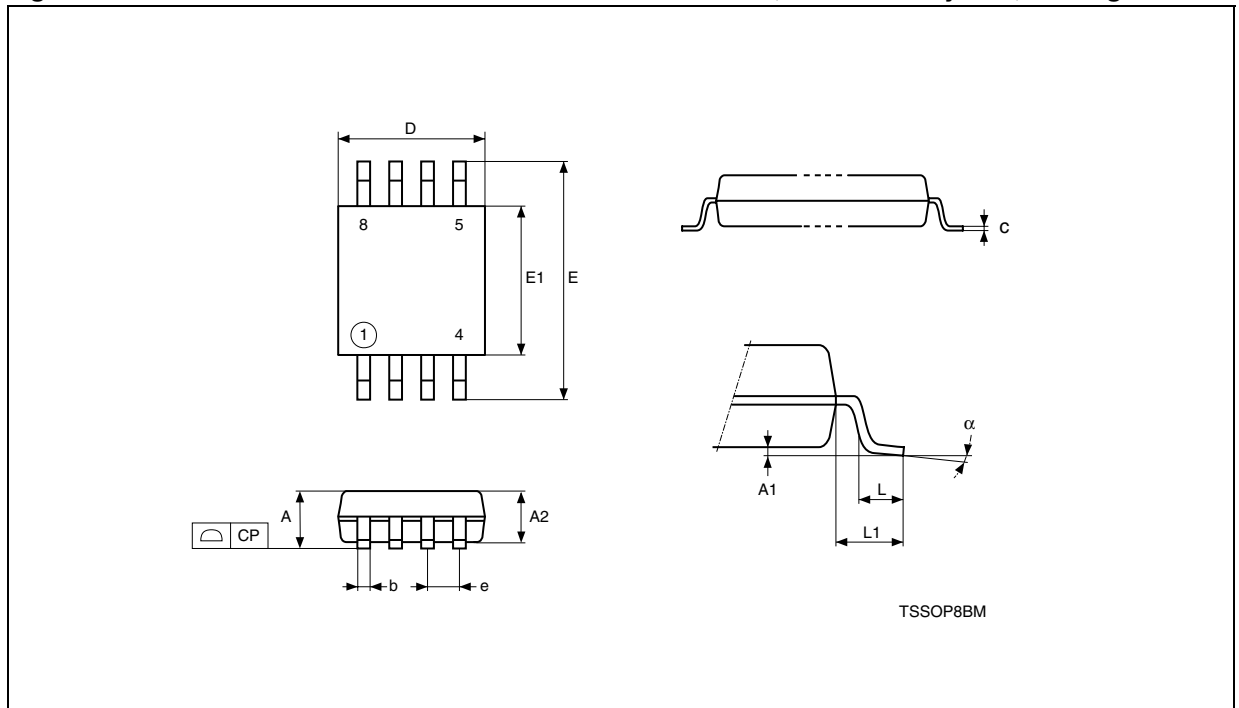

Note: Drawing is not to scale.

Table 27. TSSOP8 3x3mm<sup>2</sup> – 8 lead Thin Shrink Small Outline, 3x3mm<sup>2</sup> body size, Mechanical Data

Symbol	mm			inches		
	Typ.	Min.	Max.	Typ.	Min.	Max.
A			1.100			0.0433
A1		0.050	0.150		0.0020	0.0059
A2	0.850	0.750	0.950	0.0335	0.0295	0.0374
b		0.250	0.400		0.0098	0.0157
c		0.130	0.230		0.0051	0.0091
D	3.000	2.900	3.100	0.1181	0.1142	0.1220
E	4.900	4.650	5.150	0.1929	0.1831	0.2028
E1	3.000	2.900	3.100	0.1181	0.1142	0.1220
e	0.650	–	–	0.0256	–	–
CP			0.100			0.0039
L	0.550	0.400	0.700	0.0217	0.0157	0.0276
L1	0.950			0.0374		
$\alpha$		0°	6°		0°	6°

Figure 16. TSSOP8 – 8 lead Thin Shrink Small Outline, Package Outline

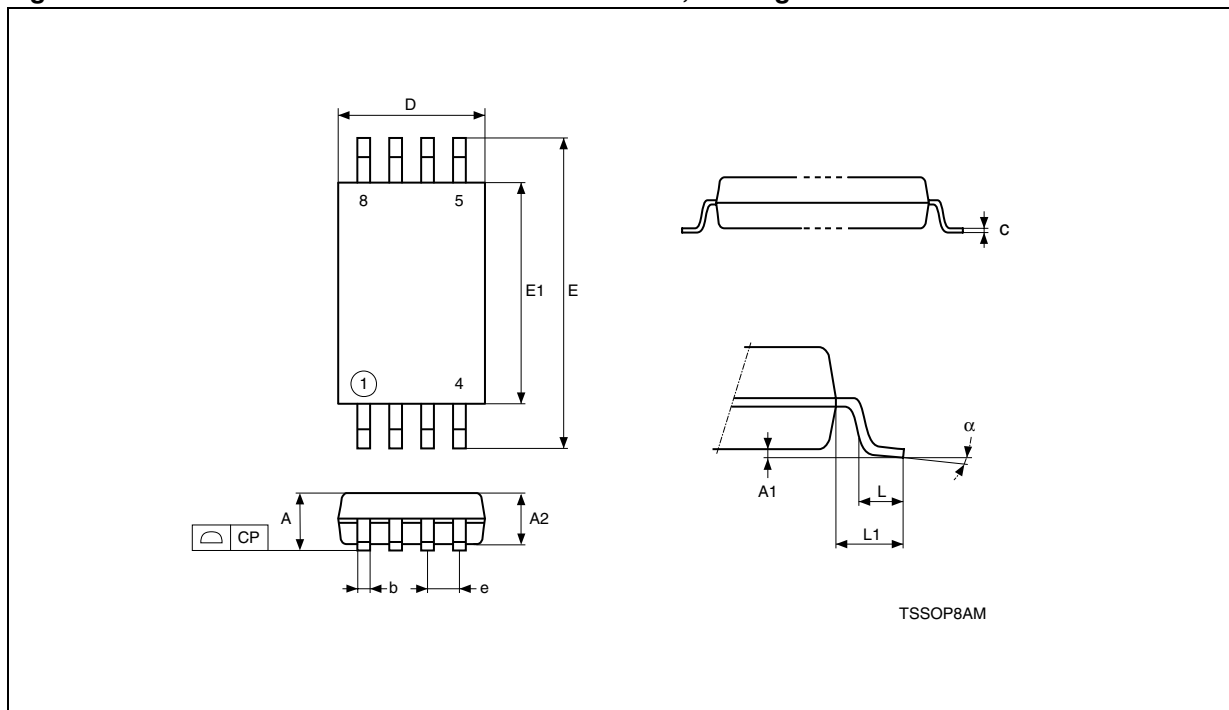

Note: Drawing is not to scale.

Table 28. TSSOP8 – 8 lead Thin Shrink Small Outline, Package Mechanical Data

Symbol	mm			inches		
	Typ.	Min.	Max.	Typ.	Min.	Max.
A			1.200			0.0472
A1		0.050	0.150		0.0020	0.0059
A2	1.000	0.800	1.050	0.0394	0.0315	0.0413
b		0.190	0.300		0.0075	0.0118
c		0.090	0.200		0.0035	0.0079
CP			0.100			0.0039
D	3.000	2.900	3.100	0.1181	0.1142	0.1220
e	0.650	–	–	0.0256	–	–
E	6.400	6.200	6.600	0.2520	0.2441	0.2598
E1	4.400	4.300	4.500	0.1732	0.1693	0.1772
L	0.600	0.450	0.750	0.0236	0.0177	0.0295
L1	1.000			0.0394		
$\alpha$		0°	8°		0°	8°

## PART NUMBERING

**Table 29. Ordering Information Scheme**

Example:	M93C86	-	W	MN	6	T	P
<b>Device Type</b> M93 = MICROWIRE serial access EEPROM							
<b>Device Function</b> 86 = 16 Kbit (2048 x 8) 76 = 8 Kbit (1024 x 8) 66 = 4 Kbit (512 x 8) 56 = 2 Kbit (256 x 8) 46 = 1 Kbit (128 x 8)							
<b>Operating Voltage</b> blank = V <sub>CC</sub> = 4.5 to 5.5V W = V <sub>CC</sub> = 2.5 to 5.5V R = V <sub>CC</sub> = 1.8 to 5.5V							
<b>Package</b> BN = PDIP8 MN = SO8 (150 mil width) MB = UDFDFPN8 (MLP8) DW = TSSOP8 (169 mil width) DS <sup>2</sup> = TSSOP8 (3x3mm body size)							
<b>Device Grade</b> 6 = Industrial temperature range, -40 to 85 °C. Device tested with standard test flow 7 = Device tested with High Reliability Certified Flow <sup>1</sup> . Automotive temperature range (-40 to 105 °C) 3 = Device tested with High Reliability Certified Flow <sup>1</sup> . Automotive temperature range (-40 to 125 °C)							
<b>Packing</b> blank = Standard Packing T = Tape and Reel Packing							
<b>Plating Technology</b> blank = Standard SnPb plating P = Lead-Free and RoHS compliant G = Lead-Free, RoHS compliant, Sb <sub>2</sub> O <sub>3</sub> -free and TBBA-free							

Note: 1. ST strongly recommends the use of the Automotive Grade devices for use in an automotive environment. The High Reliability Certified Flow (HRCF) is described in the quality note QNEE9801. Please ask your nearest ST sales office for a copy.  
2. Available only on new products: identified by the Process Identification letter W or G or S.

Devices are shipped from the factory with the memory content set at all 1s (FFFFh for x16, FFh for x8).

For a list of available options (speed, package, etc.) or for further information on any aspect of this device, please contact your nearest ST Sales Office.

**Table 30. How to Identify Current and New Products by the Process Identification Letter**

<b>Markings on Current Products<sup>1</sup></b>	<b>Markings on New Products<sup>1</sup></b>
M93C46W6 AYWWF (or AYWWM)	M93C46W6 AYWWW (or AYWWG or AYWWS)

Note: 1. This example comes from the S08 package. Other packages have similar information. For further information, please ask your ST Sales Office for Process Change Notice PCN MPG/EE/0059 (PCEE0059).

## REVISION HISTORY

**Table 31. Document Revision History**

Date	Rev.	Description of Revision
04-Feb-2003	2.0	Document reformatted, and reworded, using the new template. Temperature range 1 removed. TSSOP8 (3x3mm) package added. New products, identified by the process letter W, added, with $f_c(\max)$ increased to 1MHz for -R voltage range, and to 2MHz for all other ranges (and corresponding parameters adjusted)
26-Mar-2003	2.1	Value of standby current (max) corrected in DC characteristics tables for -W and -R ranges $V_{OUT}$ and $V_{IN}$ separated from $V_{IO}$ in the Absolute Maximum Ratings table
04-Apr-2003	2.2	Values corrected in AC characteristics tables for -W range (tSLSH, tDVCH, tCLSL) for devices with Process Identification Letter W
23-May-2003	2.3	Standby current corrected for -R range
27-May-2003	2.4	Turned-die option re-instated in Ordering Information Scheme
25-Nov-2003	3.0	Table of contents, and Pb-free options added. Temperature range 7 added. $V_{IL}(\min)$ improved to $-0.45V$ .
30-Mar-2004	4.0	MLP package added. Absolute Maximum Ratings for $V_{IO}(\min)$ and $V_{CC}(\min)$ changed. Soldering temperature information clarified for RoHS compliant devices. Device grade information clarified. Process identification letter "G" information added
16-Aug-2004	5.0	M93C06 removed. Device grade information further clarified. Process identification letter "S" information added. Turned-die package option removed. Product list summary added.

Information furnished is believed to be accurate and reliable. However, STMicroelectronics assumes no responsibility for the consequences of use of such information nor for any infringement of patents or other rights of third parties which may result from its use. No license is granted by implication or otherwise under any patent or patent rights of STMicroelectronics. Specifications mentioned in this publication are subject to change without notice. This publication supersedes and replaces all information previously supplied. STMicroelectronics products are not authorized for use as critical components in life support devices or systems without express written approval of STMicroelectronics.

The ST logo is a registered trademark of STMicroelectronics.

All other names are the property of their respective owners

© 2004 STMicroelectronics - All rights reserved

STMicroelectronics group of companies

Australia - Belgium - Brazil - Canada - China - Czech Republic - Finland - France - Germany - Hong Kong - India - Israel - Italy - Japan - Malaysia - Malta - Morocco - Singapore - Spain - Sweden - Switzerland - United Kingdom - United States of America

[www.st.com](http://www.st.com)