

PowerBLOC

Solid State Switches

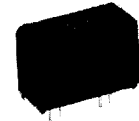
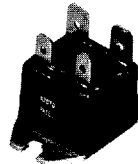

Engineering Specifications	JT(*) 1205-(X)	JT(*) 2405-(X)	JT(*) 1210-(X)	JT(*) 2410-(X)	JT(*) 2415-(X)	MX1	MX100	MX200
Output Characteristics								
Peak Blocking (V)	400	500	400	500	500	40	400	500
Output Rating (A/V_{RMS})	5/120	5/240	10/120	10/240	15/240	1.5/24	1.5/120	1.5/240
Max Off-State Leakage Current at Full Rated Load Voltage (mA)	1.0	1.0	1.0	1.0	1.0	1.0	1.0	1.0
Max On-State Voltage Drop (V_{RMS})	1.5	1.5	1.5	1.5	1.5	1.5	1.5	1.5
Critical Rate of Rise Voltage dv/dt (V/μsec @ 60°C tab temperature)								
Minimum	75	75	75	75	75	75	75	75
Max Holding Current (mA)	1.0	1.0	1.0	1.0	1.0	1.0	1.0	1.0
Typical Response Time (msec @ 60Hz)	32	32	32	32	32	32	32	32
Applied Load Voltage Before Turn-on (VAC)								
MX1	5	5	5	5	5	5	5	5
Other than MX1	25	25	25	25	25	25	25	25
Operating Frequency (Hz)								
Minimum	20	20	20	20	20	20	20	20
Maximum	500	500	500	500	500	500	500	500
Input Characteristics								
Control Voltage (DC)								
Minimum (JTA)	4	4	4	4	4	2 ⁽¹⁾	2 ⁽¹⁾	2 ⁽¹⁾
(JTB)	9	9	9	9	9			
(JTC)	20	20	20	20	20			
Typical (JTA)	5	5	5	5	5	—	—	—
(JTB)	12	12	12	12	12			
(JTC)	24	24	24	24	24			
Maximum (JTA)	8	8	8	8	8	48 ⁽¹⁾	48 ⁽¹⁾	48 ⁽¹⁾
(JTB)	16	16	16	16	16			
(JTC)	28	28	28	28	28			
Max Control Current to Operate (mA)	15	15	15	15	15	15	15	15
Min Dropout Voltage (VDC)	0.8	0.8	0.8	0.8	0.8	0.8	0.8	0.8

¹External limiting resistor required to maintain control current between 15 mA (min) and 50 mA (max).

(*) "A" designates 4-8VDC Control
 "B" designates 9-16VDC Control
 "C" designates 20-26VDC Control

(X) "1" specifies 0.3" pins
 "2" specifies Quick Connect
 "3" specifies 0.175" pins

High Voltage Option Available (H Suffix)

Features:

- Random turn-on
- Ratings to 600V, 10A
- UL recognized
- CSA approved
- DC control, AC output
- Optically isolated
- TTL and CMOS compatible

Surge and Overload Current Maximum

Duration	Load Current
1 Second	3 Times Continuous Rating
16 Milliseconds	10 Times Continuous Rating
1 Millisecond	20 Times Continuous Rating

Absolute Maximum Ratings

Parameter	Min	Max	Units
Isolation Voltage:			
Input-to-Output	2500	—	V _{RMS}
Terminals-to-Tab/Case	2500	—	V _{RMS}
Thermal Resistance:			
Junction-to-Ambient	—	41.0	°C/Watt ¹
Junction-to-Tab	—	5.9	°C/Watt ²
Input to Output Capacitance	—	4	pF
Continuous Control Current	—	100	mA
Peak Control Current (100 μsec)	—	1	A
Reverse Control Voltage	—	5	VDC
Operating Temperature	-25	75	°C
Storage Temperature	-25	75	°C
Soldering Temperature (10 seconds on leads)	—	260	°C

¹MX Series T_A = 40°C

²JT Series T_{TAB} = 65°C

All characteristics at 25°C

¹For a complete listing of CP Clare Solid State Products ask for our SSP15 catalog.

PowerBLOC

Operating Specifications

Mechanical Dimensions

All dimensions are measured in millimeters (inches).

Push-on Connectors for JT Series (18-22 AWG wire)

JT Series, Fast-on Terminals

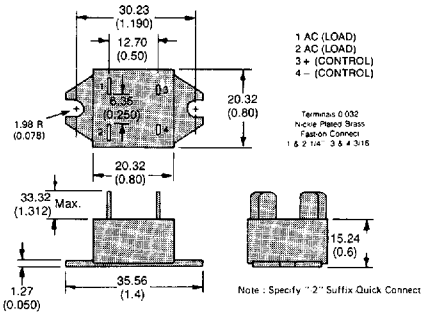

For Fast-on Terminals: 1/4" Amp #42599-20
3/16" Amp #60972-20

JT Series, Pin Terminals

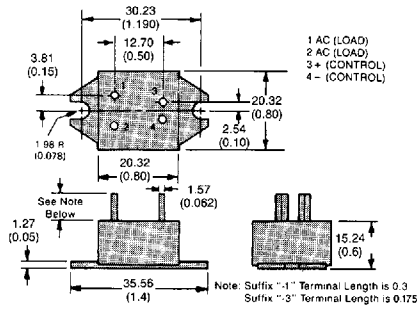

For Pin Terminals: 0.062 Molex #02-06-1103

Mx Series

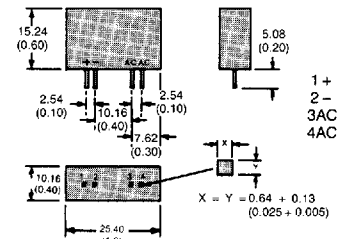

Equivalent Circuit

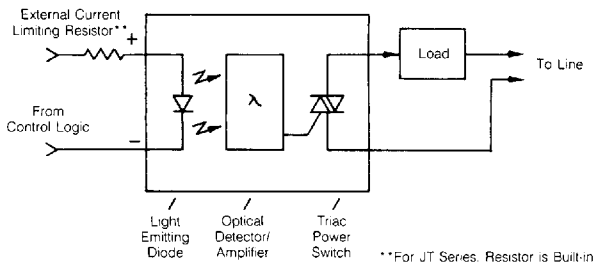

Load Current vs. Temperature (Freestanding)

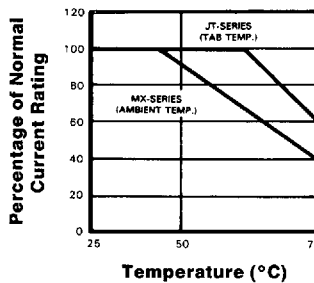

Load Current vs. Temperature (JT Series with Heat-Sink)

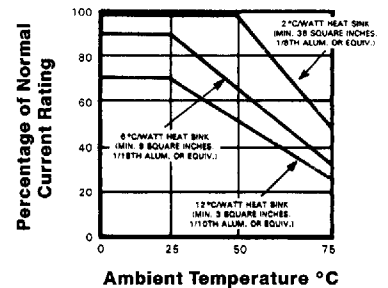

Typical Application

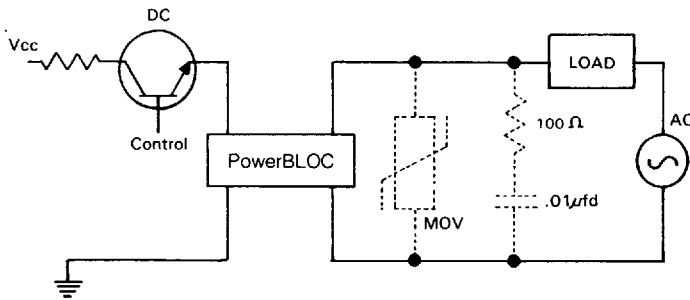

Under certain low power factor load conditions, it may be advisable to connect an RC snubber network across the SSR output. With low power factor loads, phase shifts occur which alter the circuit synchronization and prevent SSR turn-on. A snubber capacitor as small as .01 μfd compensates for the phase shift and returns the SSR to proper input signal response.

A snubber is also useful in the event of severe high voltage line spikes. While these do not generally cause damage to the SSR, they may induce false 1/2 cycle turn-on.

6 Pin Through Hole (Standard)

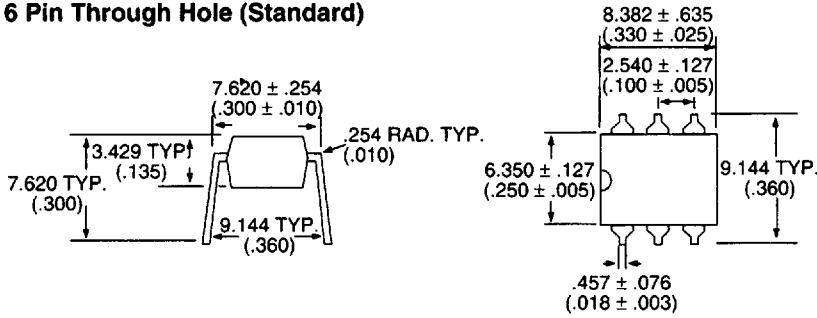

6 Pin PC Board Pattern (Bottom View)

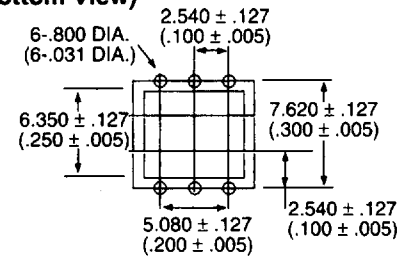

6 Pin Surface Mount ("S" Suffix)

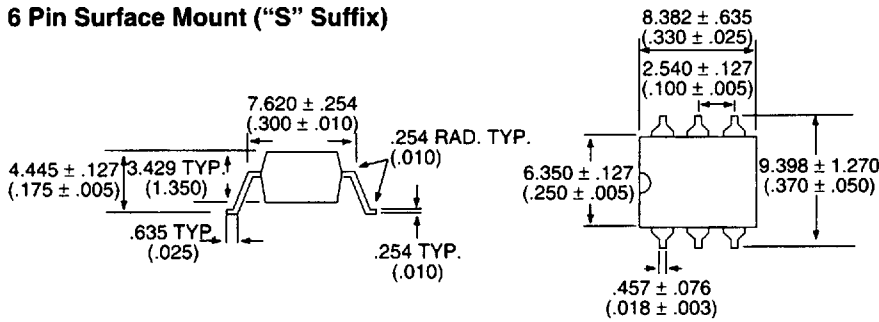

6 Pin Mounting Pad (Top View)

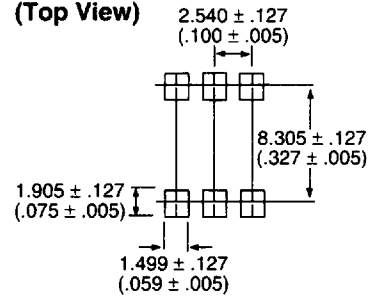

8 Pin Through Hole (Standard)

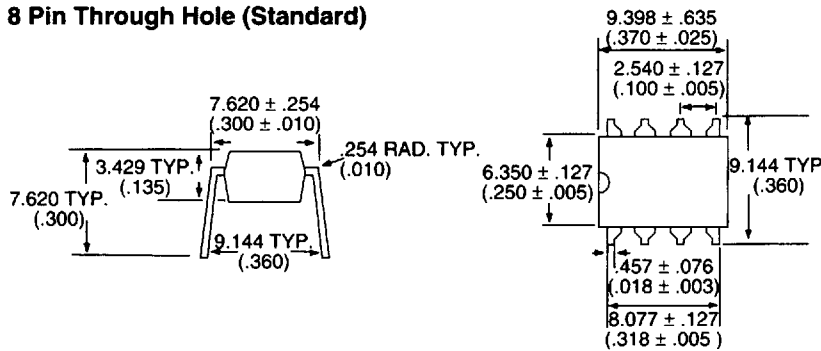

8 Pin PC Board Pattern (Bottom View)

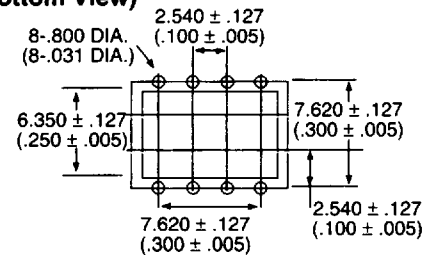

8 Pin Surface Mount ("S" Suffix)

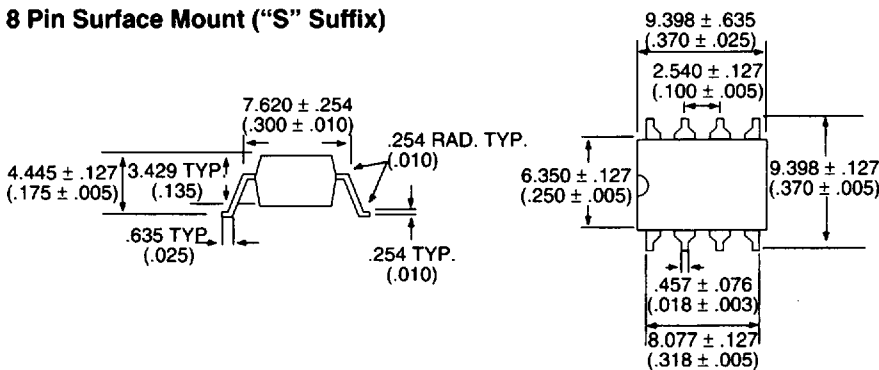

8 Pin Mounting Pad (Top View)

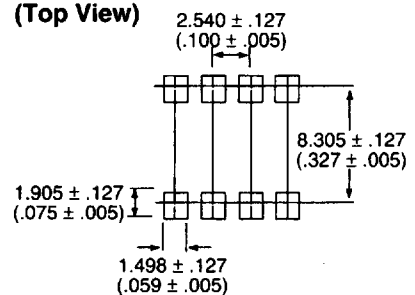

DIMENSIONS
mm
(Inches)

8 Pin Flatpack ("P" Suffix)

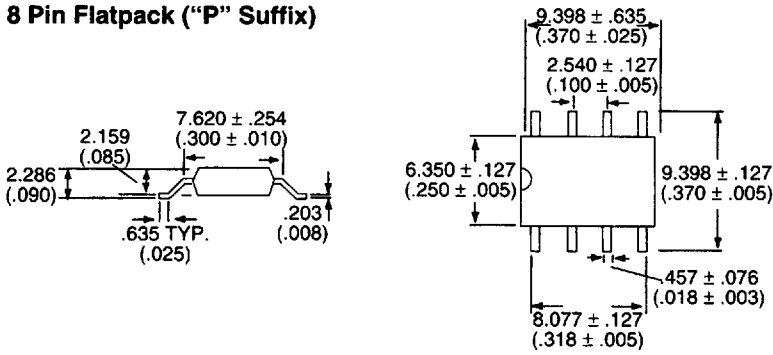

8 Pin Flatpack Mounting Pad (Top View)

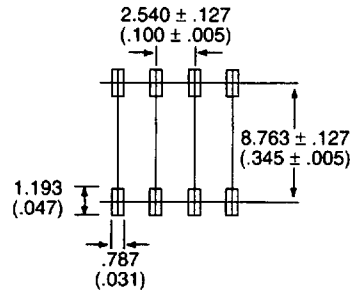

16 Pin SOIC ("P" Suffix)

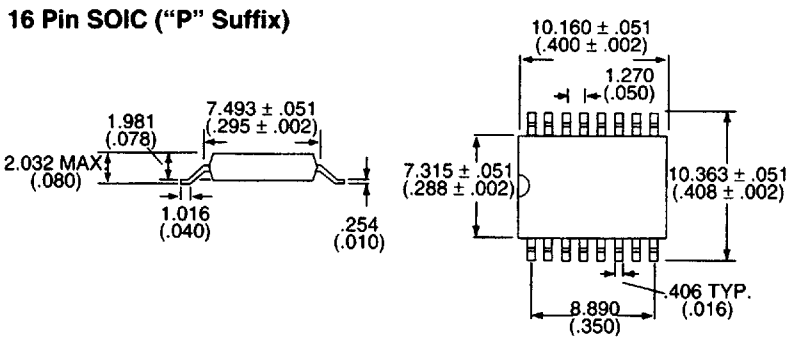

16 Pin SOIC Mounting Pad (Top View)

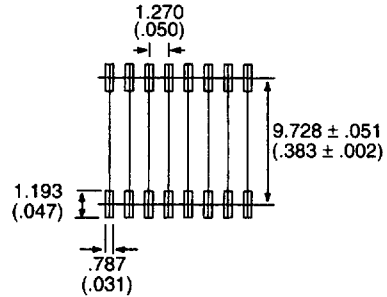

16 Pin Through Hole (Standard)

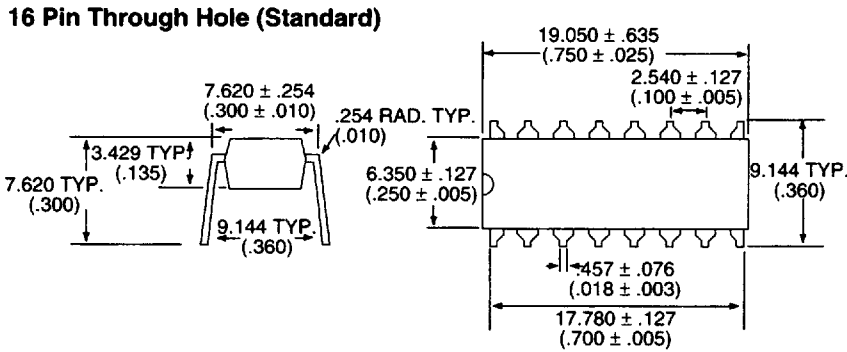

16 Pin PC Board Pattern (Bottom View)

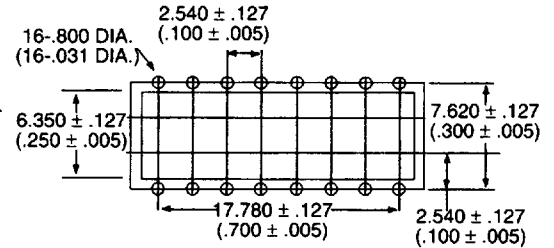

8 Pin SIP

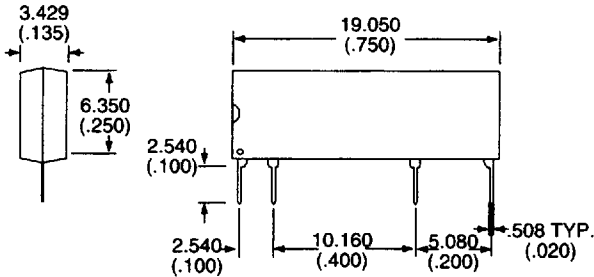

DIMENSIONS
mm
(Inches)

16 Pin DIP

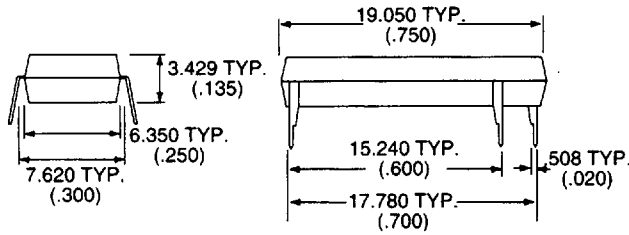

Thermal Clip

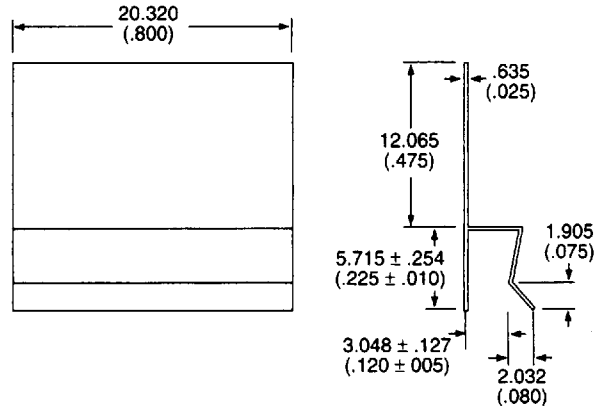

OptoFILM® 10A Series, Pins

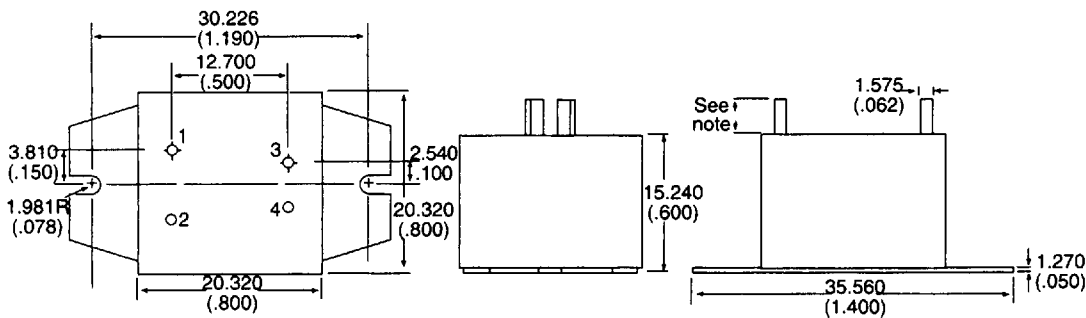

Note: Specify "-1" (0.300" pins)
 Specify "-3" (0.175" pins)

OptoFILM® 10A Series, Quick Connect

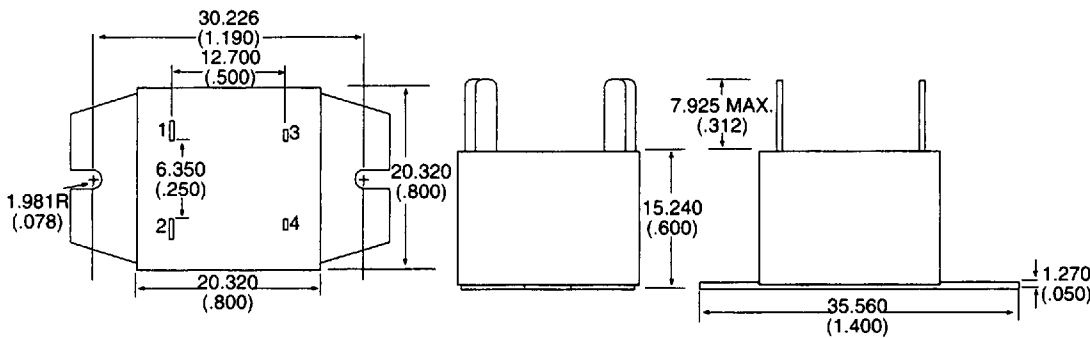

Tape and Reel Packaging for 6 Pin Surface Mount Package

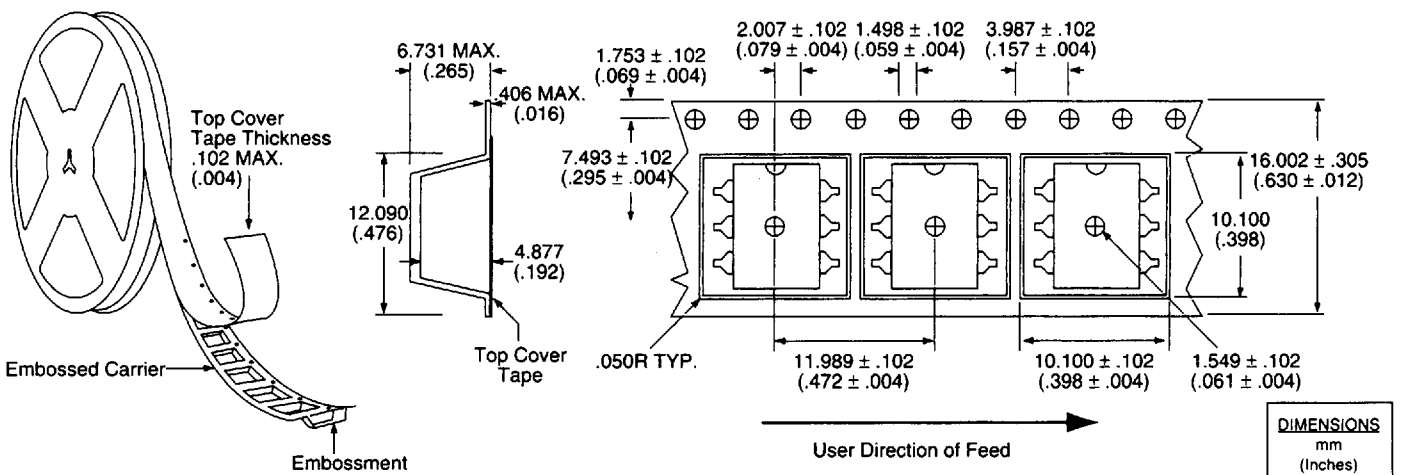

Tape and Reel Packaging for 8 Pin Surface Mount Package

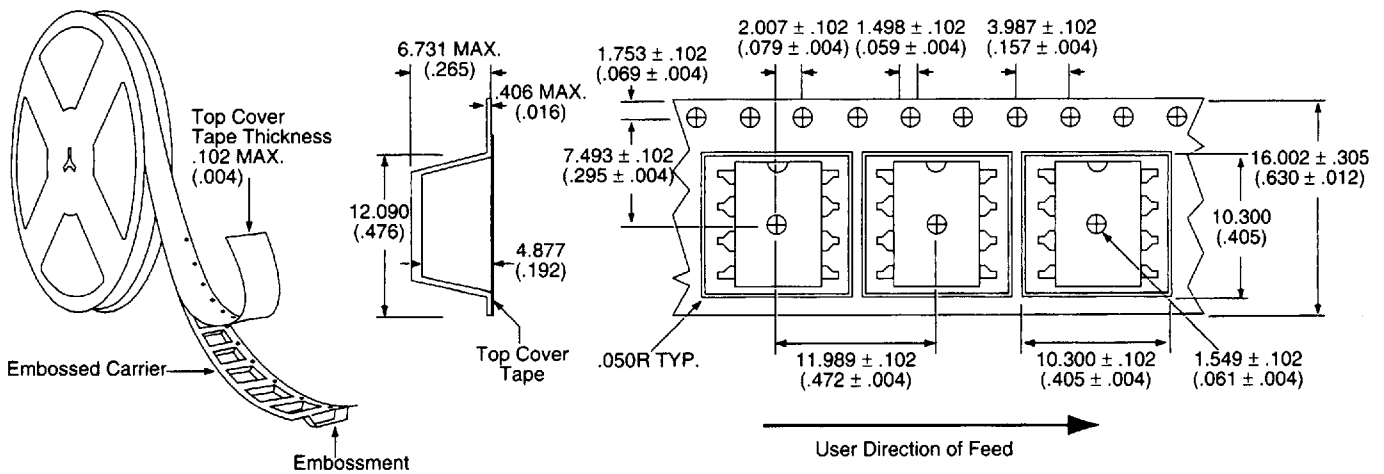

Tape and Reel Packaging for 8 Pin Flatpack Package

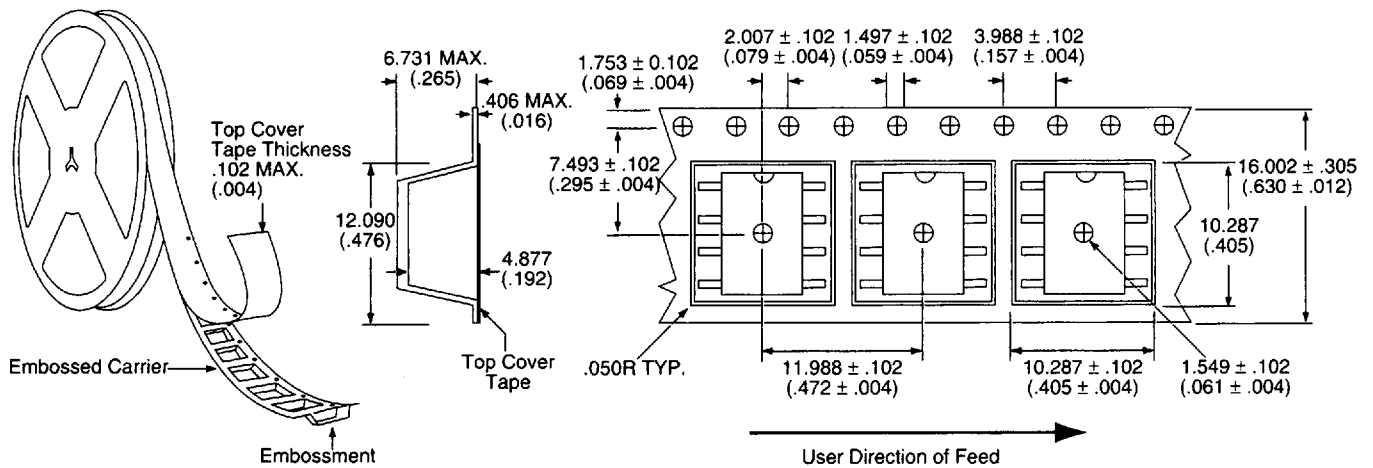

Tape and Reel Packaging for 16 Pin SOIC Package

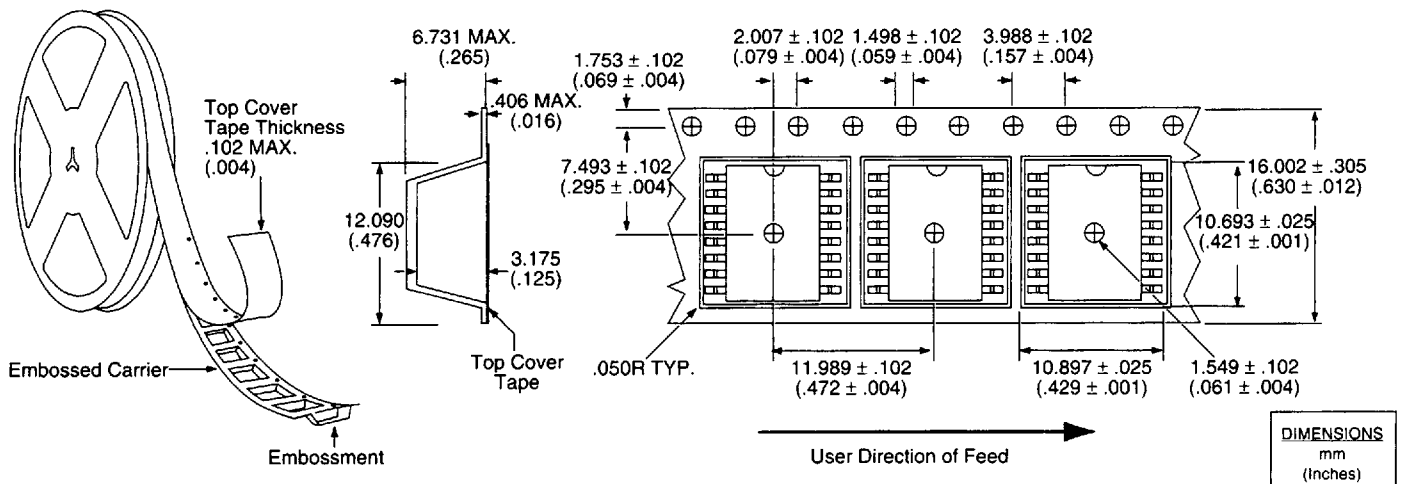

DIMENSIONS
mm
(Inches)