

"Perfecting Video with a
No-Compromise Approach
for Reproducing
the Ultimate Film Experience"

Yves Faroudja



The Faroudja
VP251 Video Processor
With Picture Plus™ Technology

**Installation & Operation
Instructions**

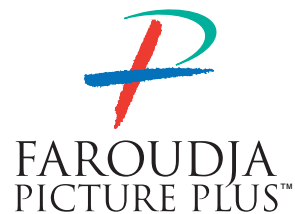

TABLE OF CONTENTS

History 2

Licensees and Awards 3

System Description 4

Inventory List 5

Caution Notes 5

Technical Highlights 6-7

Installation Instructions. 8

Operating Instructions. 9-10

Troubleshooting 11

Appendix A: RS232 Programming Instructions. 12-13

Remote Control Operation 13

Cable Specifications. 14

Specifications 15

Copyright©1998 by Faroudja Laboratories, Inc.

No part of this document may be copied, photocopied, reproduced, translated, or reproduced by any electronic medium or machine readable form without prior consent, in writing, from Faroudja Laboratories, Inc.

The Faroudja Laboratories VP251 Line Doubler is covered by the following United States patents: 4,030,121, 4,179,705, 4,240,105, 4,262,304, 4,847, 681, 4,864,389, 4,876,596, 4,893,176, 4,916,526, 4,967,271, 4,982,280, 4,989,090, 5,014,119, 5,025,312, 5,159,451, 5,237,414.

All Rights Reserved.

Some Video History and the Faroudja Approach

Faroudja Laboratories, located in northern California's Silicon Valley, was founded in 1971 by Yves and Isabell Faroudja to develop state-of-the-art video processing technology. Over the last 26 years, Faroudja Laboratories has developed hundreds of advanced electronic processes to improve video enhancement, noise reduction and NTSC encoding/ decoding technologies. Many of these processes are used under license by the world's leading electronics companies in a wide range of high performance video products. Faroudja professional video equipment is also currently hard at work in hundreds of television studios. Thus Faroudja technology is utilized and enjoyed in millions of American homes every day.

Yves Faroudja has devoted his career and his company to the goal of enabling home video systems to achieve the image quality of 35mm

motion pictures. In pursuit of this goal, Faroudja Laboratories has made use of techniques from Faroudja professional video equipment and incorporated these in the VP251/VP201/VP201U/ line doublers, VP301 line multiplier and the 401/VP401U line quadruplers. Faroudja's unique approach focuses on critical problem areas in the NTSC and PAL broadcast format. With patented engineering and design work, Yves and Faroudja Laboratories have created an exceptional product that brings new levels of visual reality to the enjoyment of discerning video enthusiasts around the world.

This booklet will provide the reader with a hands-on look at the VP251, its operation and benefits.

Also supplied is an overview of the proprietary technologies utilized in this extraordinary device and an explanation of the visual improvements it provides in home video and corporate playback systems.

This manual is for use with the VP251 which handles both NTSC and PAL sources. For simplicity the documentation references NTSC. All instructions for installation and operation are the same for PAL sources

LICENSEES AND AWARDS



On June 24, 1998 Yves Faroudja was awarded the prestigious Charles F. Jenkins Lifetime Achievement Award from the Academy of Television Arts & Sciences for his video processing technology. Faroudja's first Emmy was awarded in 1991. Some of this

Licensees Around the World

Faroudja's inventive approach to improving the quality of video imaging has caught the eye of some of the world's greatest high technology companies. The following list represents those that have recognized the value of Faroudja's solutions to imaging problems and pay for the opportunity to incorporate this technology in their advanced video products (as of January 1998):

Canon	Microtime
Conrac	Mitsubishi
General Instrument	NAC
Grass Valley	NEC
Hitachi	Sanyo
Ikegami	Sharp
JVC	Sony
Matsushita (Panasonic)	S3
	Toshiba

Awards and Achievements

Yves Faroudja and Faroudja Laboratories have garnered worldwide recognition and a number of industry awards. These honors are notable for several reasons. They are in response to the significant impact that Faroudja's technology has made on the serious improvement of video quality. They are also a reflection of his long term dedication to continually improving and optimizing the performance of the NTSC and PAL video formats.

1987: SMPTE
DAVID SARNOFF GOLD MEDAL AWARD
for
"Contributing to Optimizing NTSC Performances"

1988: MONITOR AWARD
for
"Excellence in Engineering
NTSC Encoders and Decoders"

1989: BM/E AWARD
for
"Excellence in Engineering"

1991: Technology Executive of the Year
from Cable TV Business

1991: EMMY
from The National Academy
of Television Arts and Sciences
for
"Techniques for Minimization of NTSC Artifacts
Through Advanced Encoding Techniques"

1992: VIDEO GRAND PRIX AWARD
Audio/Video International
LD100 Line Doubler "Advanced Technology Award"

1993: VIDEO MAGAZINE
Video Visionary

1995: BROADCAST ENGINEERING AWARD

1997: VISUAL GRAND PRIX AWARD
Audio Video Review Magazine (Japan)
LD200

1997/1998: RECOMMENDED COMPONENTS
Stereophile Guide to Home Theater Magazine
AAA Rating: VP250, VP400A

1998: PLATINUM AWARD
AV Video Multimedia Producer Magazine
Outstanding Achievement: VP250

SYSTEM DESCRIPTION



The Faroudja VP251 Line Doubler/Video Processor is a precision video instrument used to convert NTSC interlaced signals into 480 visible, progressively scanned lines (640X480 resolution). Using Picture Plus™ technology, the VP251 removes typical video processing artifacts while also increasing color purity and image detail, closely matching 35mm film.

The VP251 is designed as an ideal match for Data-Grade 7" CRT projectors requiring high resolution images while also increasing the projector's light output. It is also an ideal match for DLP, LCD projectors, Plasma displays and computer monitors that require high quality, progressively scanned signals.

Front panel features include Power, Input Select, Brightness, Contrast, Color, Tint, and Detail. All of the settings are automatically stored when the unit is turned off. Also, up to 32 custom presets can be set. All front panel features can be adjusted by infrared and RS232 remote control.

Inputs include: Composite Video, S-Video Component (Y,Cr,Cb/RGB) and Computer/HDTV. The Video input may be connected by either a BNC connection or a video RCA type connection. These inputs are looped internally so that other devices may use the signal.. The S-Video input uses a standard 4-pin connector.

The VP251 requires a standard P15 to RGB breakout cable when using the component input. If the looped inputs are used, these cables should be kept short (under 6' in length) or a video distribution amplifier should be used. This allows the VP251 to keep the highest signal bandwidth possible without having the high frequencies being attenuated in a long cable.

Output from the VP251 is provided by six BNC connectors as well as one 15 pin 'D' connector. The BNC outputs provided are Red, Green, Blue, Horizontal Sync, Vertical Sync and Composite Sync. Interface to monitors/projectors can be a 4 or 5 wire connection. The VP251 is capable of driving a monitor/projector using the BNC outputs as well as a 15 pin 'D' connector, at the same time. The monitor and projector must be compatible with a 31.5KHz Horizontal scan rate.

SYSTEM DESCRIPTION

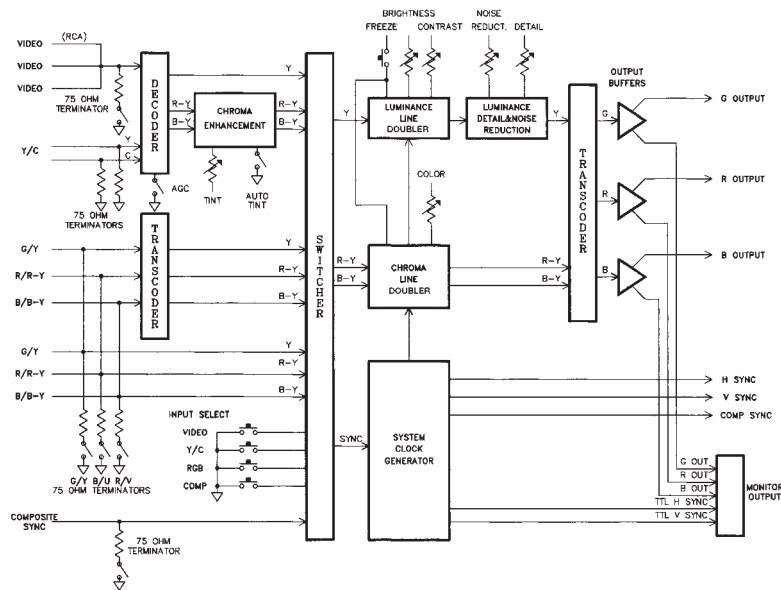

Circuit Description

Figure 1 is a block diagram of the VP251 showing signal flow and the location of front panel controls and switches. Composite Video and S-Video inputs are connected to the decoder with AGC control and converted to Y, R-Y and B-Y signals. The Y, (Luminance) output from the decoder enters the input switcher while the R-Y and B-Y signal enter the Chroma Enhancement block where the Tint phase can be adjusted when selected in the manual mode. The RGB input signals are transcoded to Y, R-Y, and B-Y signals and fed to the input switcher. Component signals are fed directly to the input switcher.

The input switcher then selects the correct function and outputs the Y signal to the Luminance Line Doubler block. The Luminance Line Doubler block contains the Brightness, Contrast and Freeze controls while the R-Y and B-Y signals enter the Chroma block where the color level can be controlled along with the Freeze controls. The Line Doubler Luminance signal now enters the Luminance Detail and Noise Reduction block where the functions of Noise Reduction and Detail Level are controlled.

The Luminance signal from the Luminance Detail and Noise Reduction block along with the R-Y and B-Y signals from the Chroma Line Doubler block feed the output transcoder and are converted to RGB signals. These RGB signals are buffered and then sent to both the BNC and monitor output connectors.

When using the RGB or Component inputs, Sync is derived from the G or Y input signals unless sync is provided to the Composite Sync input. The Composite Sync input will override the sync from the G or Y inputs. The sync signal then feeds the VP251 clock generator and is used as a reference to generate Horizontal Sync, Vertical Sync and Composite Sync.

Inventory List

- 1 VP251 Digital Video Processor
- 1 Installation/Operation Manual
- 1 Warranty Card
- 1 Power Cord

Caution Notes

Do not connect the VP251 to a Monitor/Projector not capable of the correct scan rates. (31.5KHz)

High Voltages are present inside. Opening the unit will void all warranties.

No user serviceable parts inside.

TECHNICAL HIGHLIGHTS

Picture Plus™ Technology – The VP251 is called a Line Doubler. However, just increasing the number of lines can make the image worse. This is where Picture Plus™ technology becomes critical. Picture Plus represents a complex, multi-stage process that takes advantage of all the patented Faroudja circuitry for color, motion and detail processing. How these circuits improve the picture are outlined below.

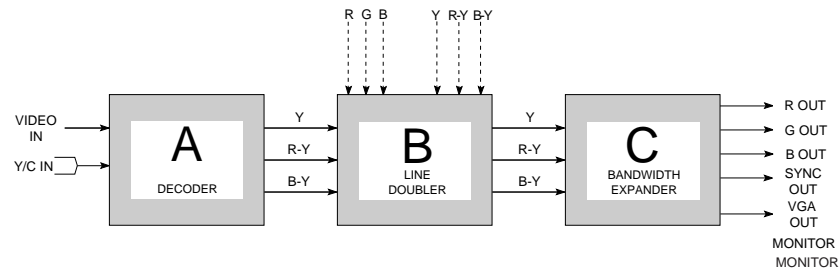

VP251 BLOCK DIAGRAM

STAGE A COLOR PROCESSING: Chroma Bandwidth Expansion + Adaptive Comb Filter + Cross-Color Suppression

COLOR BLURRING – The engineers of the 1940's (and the 1950's, before and during the development of color broadcasting), had no idea that video images would one day be blown up as large as they are today. They therefore designed the color section of the NTSC standard with severe bandwidth restrictions. This causes colors in various video images to "blur" and "smear". These effects are further aggravated by storage media such as VHS tapes, that further degrade the chroma or color signal. e.g. – note how deep reds smear on VHS tape images.

The Faroudja VP251 utilizes proprietary circuitry to recreate and further correct color details. Technically, this is accomplished by making use of the sharper black and white transitions to develop a correction signal that is then used to sharpen the color transitions. The result is colors that are restored with sharp details and video images that retain their original crisp look.

RAINBOW PATTERNS – When you notice the fine detail of a striped referees shirt rippling with colored rainbows as the camera pans by, you've seen video cross-color interference.

This annoying artifact is caused by imperfect separation of the color (chroma) and black and white (luminance) signals, by the color decoder circuitry. Simple techniques used commonly to separate the two signals can be effective most of the time but occasionally are fooled by finer pitch detail areas like the referee's shirt. The VP251 has patented cross color suppression that eliminates decoding errors of this type and enables the reproduction of sharper, cleaner color images.

DOT CRAWL and HANGING DOTS – This phenomenon is easily seen with large, highly colored, stationary graphics like titles and credits. Dot crawl is a rapid upwards movement of colored dots on sharp vertical transitions. Hanging dots lie underneath all the colored horizontal transitions. Both of these color aberrations are artifacts that appear due to an imperfect color decoding process. The VP251 has an adaptive comb filter that eliminates both of these distortions. The impact is color transitions that are clear, sharp and natural.

STAGE B LINE PROCESSING: Film/Video Motion Tracking

THE VP251 Patented Line Multiplier: eliminates VISIBLE SCAN LINES – The secret of the VP251's uncanny ability to increase the lines of information without adding digital artifacts is in its unique ability to detect motion and interpolate correctly. The Faroudja VP251 does this thanks to its proprietary, patented circuitry. It can detect the difference between a film image that has been transferred to video or video image that emanated from a video camera. After detecting the image type, the VP251 adjusts its algorithm to compensate accordingly.

This is critical because today's home theaters are primarily used to show films that were transferred to video whether on tape, laserdisc or off the air (virtually all prime time programs are film transferred to video). The VP251 offers sharper, uniquely clean, artifact-free film-like images without visible scanning lines.

Again, historically speaking, electrical engineers in the 1940's knew the resolution of a picture tube was dependent on two different mechanisms. Horizontal resolution is a function of bandwidth (frequency response) of the

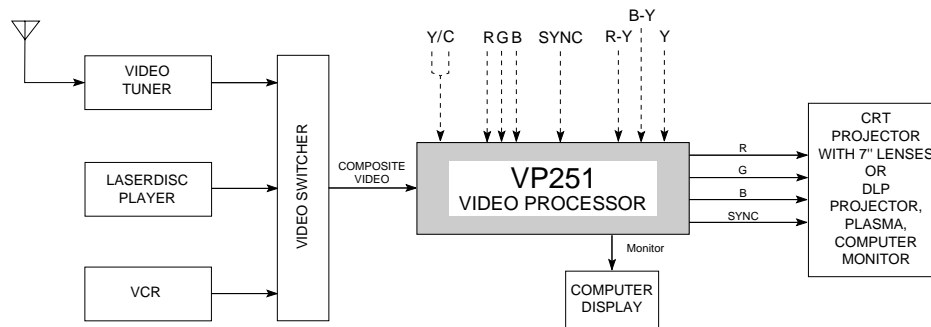

TYPICAL VP251 SYSTEM UTILIZATION

circuitry, while vertical resolution is a function of the scanning frequency (the number of scan lines in each picture). Given these mechanisms and with an average size picture tube of 8-10", they designed the 525 line broadcast standard so that viewers would not see the scan lines when watching TV. They had no idea that someday people would be projecting home theater video images with diagonal screen sizes of 10' and more.

Based on those NTSC parameters, using a 10 ft. diagonal screen would require the viewer to be located more than 45 ft. from the screen to see the picture as it was intended without scan lines! Unfortunately, today's large screen installations have scan lines that are quite visible, especially with some of the latest high resolution monitors and projection televisions. The VP251 eliminates this problem by scan doubling the 525 interlaced lines (only 480 lines are actually visible) to become 480 progressively scanned lines. The result is the elimination of visible scan lines and increased brightness and detail. The image produced by the VP251 is virtually film-like in detail, motion and color.

STAGE C DETAIL PROCESSING: Luminance Bandwidth Expansion

There is a major limitation with most contemporary program sources — lack of frequency response. The best video sources such as satellite dish reception and laserdiscs can provide acceptable resolution (400 plus lines of horizontal resolution). Other more common sources however, such as VHS tapes (230 lines), are

clearly deficient. The problem is compounded when the scan lines are doubled along with other signal processing. The lack of high frequency detail becomes very obvious when the more common sources are used.

The resultant picture is free of scan lines but dull, with a serious loss of definition. The solution is to expand the high frequencies without producing annoying and picture degrading artifacts.

The bandwidth expansion circuitry in the VP251 is exceptionally sophisticated, using Faroudja's double differentiation techniques to sharpen the edges of both horizontal and vertical details. The result is a sharply detailed image that appears crisp and three dimensional with no visible negative side-effects. This process can effectively double the perceived bandwidth and therefore the resolution of the incoming signal.

FAROUDJA VP251 APPLICATIONS – While the technical accomplishments of the VP251 represent years of intense research and development, its use is straightforward and direct. The block diagram (above) illustrates a typical home theater system configuration and shows how the VP251 would be inserted in the signal path. Many entertainment sources benefit greatly by the VP251's unique attributes; laserdisc, VHS video, S-VHS, DVD, cable TV, broadcast TV, etc. The VP251 has proven to be an invaluable tool in other presentation disciplines where image quality is important; computer data displays, professional installations in boardrooms and media rooms, military installations, government agencies and academic uses in schools and colleges. From the quality of its individual parts to its state-of-the-art patented circuitry, the VP251 is truly in a class by itself. There is simply no finer video processor available.

INSTALLATION INSTRUCTIONS

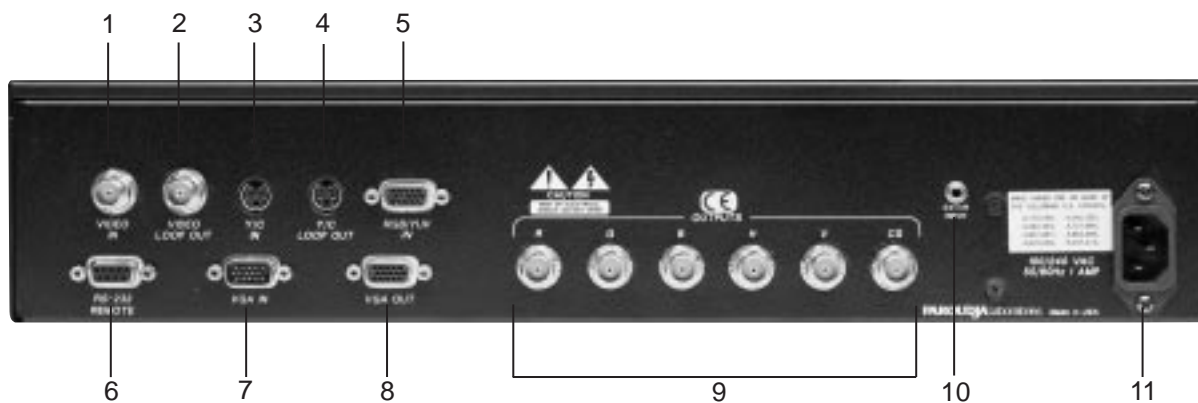

Figure 2

Unpacking

Remove the VP251 from the shipping container and examine it for any signs of shipping damage or missing items, (check inventory list on page 5).

All shipping materials should be saved if the unit is to be moved or should need to be returned for service or repair.

Installation

The VP251 is designed to be placed on a table or rack mounted. If the rack mounting installation kit is to be used, the rack mount ears are installed by removing the 4 ears using the 4 screws. Remove the four feet from the unit. When installing in a rack, it will be necessary to support the unit by using rack support rails supplied by the rack manufacturer.

Do not support the unit by the rack mount ears alone!

Contact Faroudja to order rack kits.

Ventilation

The VP251 will require that air flows freely through both the bottom and top vent holes. Blocking these holes will greatly reduce the reliability of the unit and lead to the possibility of overheating.

When the unit is rack mounted, a minimum of 1.25" (1 rack unit height) of free space is to be provided for both the top and bottom of the unit to allow for proper cooling. It is also recommended that the rack be forced air cooled.

Figure 2

Rear Panel I/O

1. Composite Video Input
2. Composite Video loop-through (Auto-terminating)
3. S-Video Input
4. S-Video Loop-through (Auto-Terminating)
5. YUV/RGB input (requires D15 to RGB breakout cable)
6. D9 connection for RS232
7. Computer/HDTV input
8. D15 monitor connection
9. BNC Video output connectors
10. External infrared sensor plug 1/8" stereo jack
11. Power Input

VIDEO PROCESSOR OPERATING INSTRUCTIONS

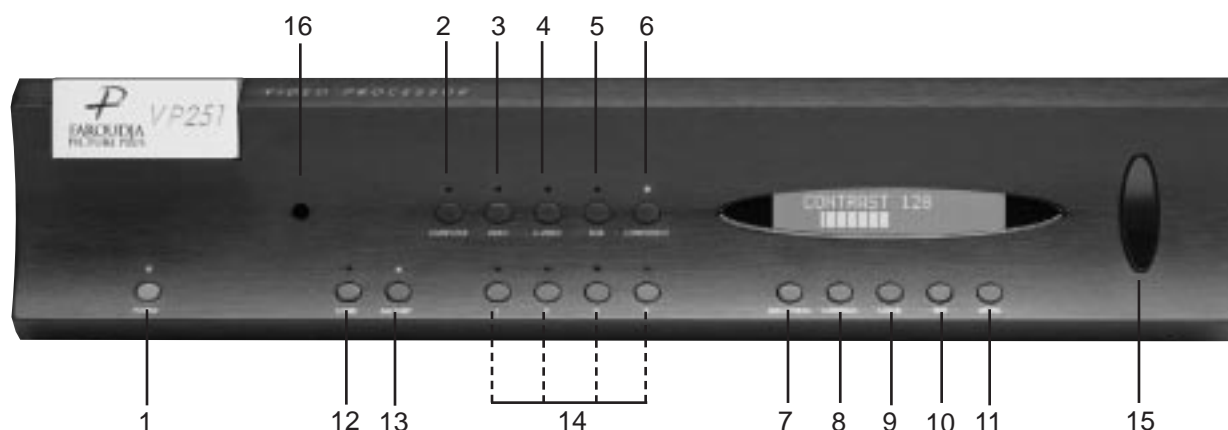

The VP251 Control panel

On-Screen-Display On-Off

Simultaneously press the Factory and Preset 1 buttons

Selecting a push button control lights the adjacent LED to indicate activation or selection of that particular function.

- 1) **Power ON/OFF** – Press the button and the LED lights green to indicate POWER ON. When the VP251 powers up it is automatically set to operate just as it was when it was last turned off.

Power ON/OFF – Another push on the switch and the power is cut off extinguishing the green LED. The Freeze Circuit is automatically disengaged, if in use, upon turn off.

INPUT SELECTION SWITCHES

Press to Select

- 2) **Computer/HDTV** – This control refers to any high resolution source such as HDTV or computer signals connected to the D15 input. Signal is “passed through” to the D15 and BNC outputs. The signal is not processed by Faroudja circuitry.
- 3) **Video** – refers to any composite NTSC video signal - (e.g. VCR's, laserdisc players, cable boxes, etc.)
- 4) **S Video** – refers to any source that outputs S-Video signals (DVD, S-VHS, satellite receivers, etc.). Using the input allows one to realize all the benefits of maintaining the separation of the luminance (picture) and chrominance (color) signal through the video signal processing chain, thus avoiding rainbow patterns and dot crawl.
- 5) **RGB** – refers to the incoming video signal broken down to the individual red, green and blue format more typically found in the professional and broadcast area.
- 6) **Component Input** – refers to the video signal in its component form (Y, R-Y, B-Y or Y, Cr, Cb for DVD) carried in a 3-wire cable.
- 7) **Brightness** – The Brightness control adjusts the black levels in the image. The level should be adjusted so that the color black is achieved (not gray) yet faint details should still be observable in the shadows. It is best to use a test pattern known as a PLUGE to set the levels.
- 8) **Contrast** – This control adjusts the level of white in the image. Using a well-lit image, adjust the contrast for the brightest image but not so bright that white areas start to turn green or cause blooming. Blooming is seen as bright areas of the picture smearing off to the right. It is best to use a test pattern known as PLUGE to set the levels.
- 9) **Color** – This control adjusts the amount of color in the image. Adjust to individual taste. The VP251 has an AGC (Automatic Gain Control) that adjusts the color level automatically to maintain optimum color settings, using the customer's adjusted setting as a reference. It is best to use a test pattern known as SMPTE color bars with a blue filter to properly set the levels.
- 10) **Tint** – This control adjusts the color phase seen as the range from green to magenta. The VP251 has an APC (Automatic Phase Control) that maintains proper phase. This setting is best left in the preset position. It is best to use a test pattern known as SMPTE color bars with a blue filter, to properly set the levels.

VIDEO PROCESSOR OPERATING INSTRUCTIONS

Figure 4

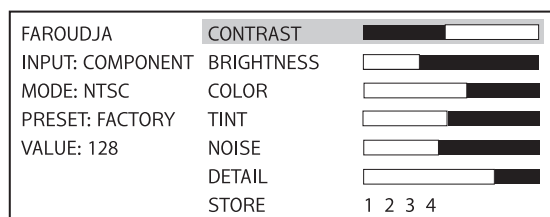

The adjustment levels can also be seen on the projection screen for easy adjustment.

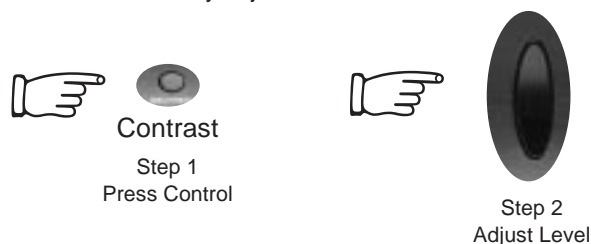

- 11) **Detail** – This control adjusts the amount of large and small edge details. The level should be set where there is the maximum amount of edge detail without excessive “ringing” and harshness. For most sources, this should be left in the preset setting.
- 12) **Store** – Press this button to activate the store function. The next preset pressed will store the current settings.
- 13) **Factory** – The Factory Presets are set to broadcast industry standards. And can be used as a reference or to reset levels if they get misaligned.
- 14) **Presets** – This control stores all picture adjustments in a nonvolatile memory. There is a separate bank of four presets for each input, that are automatically recalled when the input is selected.
- 15) **Value Adjust** – This rocker switch adjusts the value of each function. Pressing the top portion increases the level, pressing the bottom portion reduces the level.
- 16) **IR Window** – Receives the information from the remote control. Do not block this sensor.

DETAIL CONTROLS

The VP251 offers an advanced Detail circuit. The control works provides optimum picture detail without introducing “ringing” artifacts for both horizontal and vertical edges. This is very helpful with low quality sources such as VHS tapes. Also, even high quality sources such as DVDs and Laserdiscs can have excessive detail enhancement recorded in the movie this can be seen as white halos along dark edges. The detail controls can be reduced, to limit the visibility of the halos.

However, for the most part, the settings should be left in the preset setting. If the detail level must be turned way up to see details, there is a good chance there are other factors involved, such as the projector becoming out of focus

PICTURE CONTROLS

The front panel offers complete controls of key picture adjustment parameters; Brightness, Contrast, Tint, Color and Detail.

To adjust the different controls simply press the button associated with the parameter to be adjusted and toggle the value key up or down (see Figure 4). The LCD readout on the front panel provides a status report with both numbers and a bar graph for setting levels.

Presets – Once the levels have been adjusted for the best image they can be stored as one of four presets. There are four present for each input source, i.e. four for Video, four for S-Video, etc.

To store, first adjust the image then press the Store button. The next preset button pushed, will store those settings. The preset will automatically be recalled the next time that input is selected.

The Factory Preset button recalls all settings to SMPTE reference standards. When aligning the projector for the first time, the VP251 should be in the factory preset. Using an external test pattern from a DVD, laserdisc or pattern generator, adjust the brightness and contrast using the projector’s controls. Then adjust Color, Tint, and Detail using the controls on the VP251. Once completed, store the settings in one of the presets.

To store presets using the On-Screen-Display (OSD) with the infrared remote, first adjust the setting for the best image possible, then use the Function key to scroll down to the Store function. Use the Value key to select which preset to store the information. The information will be stored either when the Function button is touched again or when the OSD times off (after approx. 10 seconds).

Select the different presets by pressing the Preset button on the remote.

OSD Off – The OSD can be turned on and off by pressing the Factory button and the Preset 1 button at the same time.

TROUBLESHOOTING

Many of the new generation of projectors and computer monitors require TTL sync levels to operate correctly. The D15 output on the Faroudja processors output TTL sync. The best approach in these circumstances is to use a standard D15 to RGB breakout cable and connect it to the D15 connection on the Faroudja processor. Use the H & V sync from the breakout cable and the R, G, B from the BNC connectors on the rear panel for the best image.

Problem	Solution
No power light	Unit not turned on Unit not plugged in Fuse blown No power at plug
No picture	Video source not selected No video source connected or operating Projector/Monitor not turned on Projector/Monitor not connected correctly Bad video cable Unit in freeze mode Check brightness and contrast levels
Colors bleeding	Check termination Check projector/monitor termination Contrast set too high Color set too high
Picture not stable	Check interface cables Sync cables are swapped or not connected Input source not selected correctly Check input terminations Projector Fast/Slow Horizontal time constant. Should be set to fast.
Incorrect colors	Tint in manual mode Defective output cable RGB cables are swapped Check projector/monitor termination Input source not selected correctly No burst on input RGB or Y,R-Y, B-Y Inputs not terminated.
Picture washed out	Composite input not terminated

NOTE: To make sure that an input source is not the cause of a problem for a composite source, turn the termination switch off and connect a composite monitor to the composite input Loop input.

To make sure that a projector is not the cause of a problem, connect a 31.5KHz multisync monitor to the 15pin output connector and check the display to see if it is correct or if the monitor display shows the same problem as the projector display, then the VP251 has a problem and you should contact our Technical Support Department.

APPENDIX A

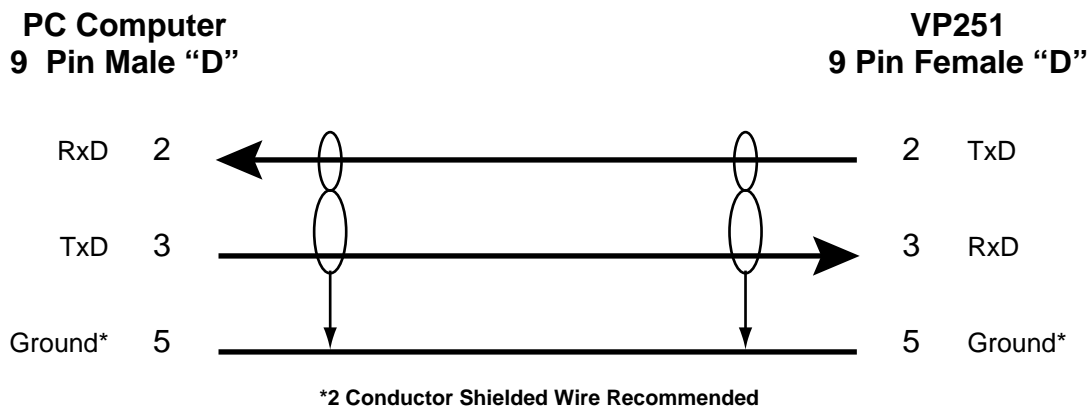
**VP251 RS-232 Cable****RS-232 PROGRAMMING INSTRUCTIONS**

The VP251 can communicate with other controllers that provide an RS-232 interface. Adjustable baud rates are 19,200, 9,600, 4,800, 2,400 and 1,200 with 9,600 as factory default. (Contact factory for details if baud rate needs to be changed.)

Communication settings are 8 bits, N parity and 1 stop bit. A terminal emulator program, like the one found in Windows, can be used to control the VP251.

All RS-232 commands require the header of 'VP251' to be used at the beginning of each new command string, followed by any of the commands listed below. Commands may be of either upper or lower case characters. All commands are terminated by a carriage return (13H).

RS-232 Commands :

The following commands can be listed a a multiple command separated by a comma:

B = Brightness (0 to 255)

C = Contrast (0 to 255)

K = Color (0 to 255)

T = Tint (0 to 255)

D = Detail (0 to 15)

Example: VP251,B100,C75 (ENTER)

The following commands must be entered individually:

HELP = Displays a help menu

P0 = Factory Preset (not user changeable)

P1 = User Preset 1

P2 = User Preset 2

P3 = User Preset 3

P4 = User Preset 4

L1 = Store User Preset 1

L2 = Store User Preset 2

L3 = Store User Preset 3

L4 = Store User Preset 4

ON = Turn On the VP251

OFF = Turn Off the VP251

ST = Return current settings status to controller

V = Select Video Input Mode

Y = Select Y/C Input Mode

X = Select YUV Input Mode

R = Select RGB Input Mode

G = Select VGA Input (Computer/HDTV pass-through)

E0 = Echo Off

E1 = Echo On (default)

The On-Screen-Display (OSD) location on the monitor can be changed using RS232 commands. The OSD can also be disabled by RS232.

OSD ON = Enable the OSD

OSD OFF = Disable the OSD

OSD xxx,xxx = (Where xxx = 0 to 152) Select placement of OSD (factory default: 0,35)

OSD can also be changed by moving a jumper located inside the unit. Contact factory for details.

ST or st This command will return a string showing the current settings of the VP251. Example:

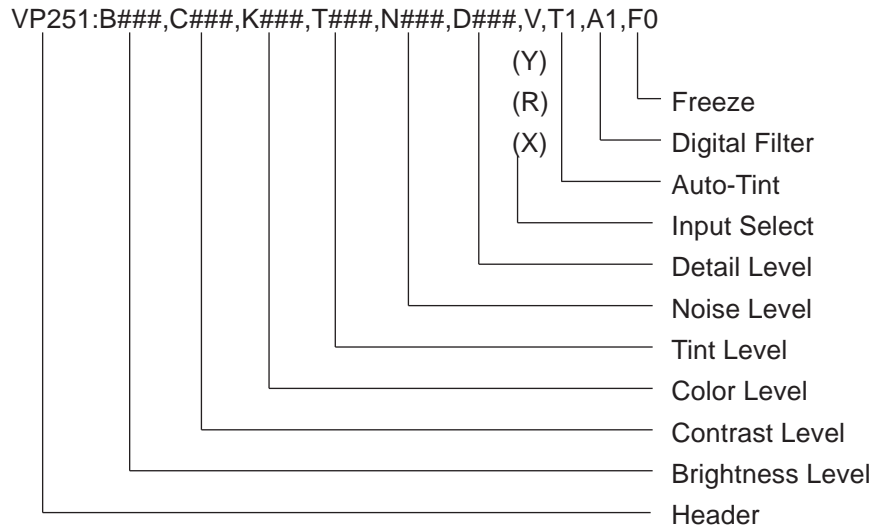

HELP or help This command will return a list of commands used for the VP251Line Multiplier.

VP251 Local / Remote Operation

The unit stores all of it's settings in a non-volatile ram and will return to the last known settings when the unit is power up. The only exception is the Freeze function. The Freeze function will be set off during the power up cycle.

When a command is received via the RS-232, only those functions are placed in the remote mode. If a function is set via the remote, it can be returned back to local mode by adjusting that function on the front panel. This is accomplished by creating a window around that function when in remote mode. If that function is turned beyond the window setpoint, that function is returned to local mode and becomes active again.

Command String Examples:

Commands can be as simple as:

VP251,B150(CR)

to complex as

VP251,D240,N20,C150,B102,V,T0,A1,F0(CR)

Note (CR) = Carriage Return (0x0d) or ASCII 13

APPENDIX A

VGA Connector and Component Video
connector Pinout

Pin	Function
1	Red Video
2	Green Video
3	Blue Video
4	Not Used
5	Ground
6	Red Return (Ground)
7	Green Return (Ground)
8	Blue Return (Ground)
9	Composite Sync
10	Composite Sync Return (Ground)
11	Not Used
12	Not Used
13	Horizontal Sync
14	Vertical Sync
15	Not Used

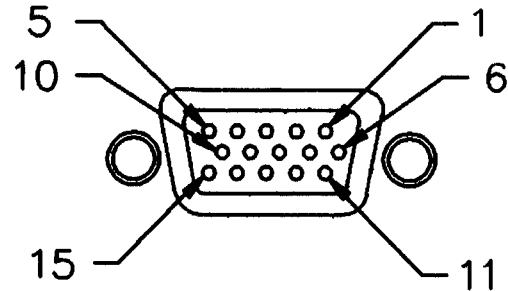

15 PIN 'D' VGA CONNECTOR
FRONT VIEW

Cable Lengths and Distribution Amplifiers

To achieve the best results from your installation, we suggest the following minimum standards for cable runs when a VP251 is used.

To preserve the video quality of the VP251, the signal path should be no more than -3db down at 25 MHz through a 75 ohm cable. Any distribution amplifier should have a bandwidth no less than -3db down at 25 MHz.

The following cable lengths are the maximum recommended continuous lengths of 75 ohm coax cable and 15 pin VGA cable (when using the VGA output).

Cable Type	Maximum Length
Mini BNC cables, 75 ohm 1.15nS/Foot propagation	100 Feet
RG-59/U type cable, 75 ohm	150 Feet
75 ohm precision video cable Belden 8281	200 Feet
15 pin, high resolution VGA cables utilizing individual high resolution mini-coax cables for each signal from VP251 to monitor.	25 Feet

SPECIFICATIONS

INPUT SIGNALS (NTSC)	525 Line 2:1 Interlace
Video	1Vp-p, Negative Sync, 714mV Luminance
S-Video	Y/C (3.58) Non-Composite, 700mVp-p Y, 286mVp-p C (Burst)
RGB	700mVp-p Non-Composite, 1Vp-p Composite
YUV	Y(1V w/Sync), R-Y(714mV), B-Y(714mV)
INPUT SIGNALS (PAL)	15 pin 'D' Connector, Computer or HDTV
	625 Line 2:1 Interlace
Video	1Vp-p, Negative Sync, 700mV Luminance
Y/C	Y/C (4.43) Non-Composite, 700mVp-p Y, 286mVp-p C (Burst)
RGB	700mVp-p Non-Composite, 1Vp-p Composite
YUV	Y(1V w/Sync), U(700mV), V(700mV)
OUTPUT SIGNALS (NTSC)	525 Line Progressive Scan/1050 Line per Frame
R, G, B	Non-composite, Positive, 714mVp-p
Vertical Sync	59.94Hz, Negative, 4Vp-p, 75 Ohm
Horizontal Sync	31.5KHz, Negative, 4Vp-p, 75 Ohm
Composite Sync	31.5KHz/59.94Hz, Negative, 4Vp-p, 75 Ohm
Output: VGA: (Line Doubler Mode)	RGB 0.700mV Pk-Pk @ 75 Ohms Horizontal Sync, BNC, 31.4 Khz, TTL @ 2K Ohms Vertical Sync, BNC, 59.94Hz, TTL @ 2K Ohms Composite Sync, BNC, 31.4 Khz H, 59.94Hz V, TTL @ 2K Ohms
D-15	VGA Standard Note: The scan frequencies are not modified when using the D-15 input loop.
OUTPUT SIGNALS (PAL)	625 Line Progressive Scan/1250 Line per Frame
R, G, B	Non-composite, Positive, 700mVp-p
Vertical Sync	50Hz, Negative, 4Vp-p, 75 Ohm
Horizontal Sync	31.25KHz, Negative, 4Vp-p, 75 Ohm
Composite Sync	31.2KHz/50Hz, Negative, 4Vp-p, 75 Ohm
POWER INPUT:	100-240 VAC, 50/60Hz, 35 Watts (Auto ranging)
DIMENSIONS:	3.5" H x 17.00" W x 16.50" D 66.675mm H x 431.8mm W x 419.1mm D
WEIGHT:	17 LBS, 6.34 Kg

Design and specifications are subject to change without notice.

WARRANTY INFORMATION

All FAROUDJA Laboratories products are warranted to the original purchase against defective materials and workmanship under normal use and service for a period of one (1) year from the date of shipment. This warranty shall be of no force and effects if modifications have been made by the purchaser or its agents or employees or if damage results from connecting the product to incompatible equipment or power. This warranty will also be void if the product is not returned to FAROUDJA Laboratories in the original shipping container.

The purchaser's sole remedy with respect to the breach of this warranty is for the selling distributor to repair or replace, at its option, those products which the selling distributor determines to have breached this warranty within the specified period.

Any claims under this warranty should be made by telephone or in writing to the selling distributor or FAROUDJA Laboratories. No products should be returned to the selling distributor or to FAROUDJA Laboratories without its prior consent, and then, only with freight prepaid. FAROUDJA Laboratories will prepay the return shipment.

Specifications and price change privileges are reserved.

THIS WARRANTY IS IN LIEU OF ALL OTHER WARRANTIES EXPRESSED OR IMPLIED INCLUDING, WITHOUT LIMITATIONS, ANY IMPLIED WARRANTY FOR MERCHANTABILITY OR FITNESS FOR A PARTICULAR PURPOSE.

FAROUDJA Laboratories
750 Palomar Ave., Sunnyvale, California 94086
Tel: 408-735-1492 Fax: 408-735-8571