

# OvationONS™ II Wireless Laser Navigation System-on-Chip

## Features

- Programmable blocks
  - Highly integrated wireless mouse-on-a-chip with programmable PSoC® microcontroller unit (MCU)
  - 16 KB flash memory
  - 2 KB static RAM (SRAM)
  - Internal 24-, 12-, or 6-MHz main oscillator (IMO)
  - Internal 32-kHz low speed oscillator (ILO)
  - 16-bit data report enables simultaneous high speed and high resolution tracking
- Tracking performance
  - Selectable resolution of 400, 800, or 1600 counts per inch (CPI), independent of speed
  - High speed with high accuracy tracking
  - Speed up to 30 inches per second (in/s)
  - Acceleration up to 20 g
- Peripheral Interface
  - SPI master interface to radio for wireless applications
  - Fast or standard mode I<sup>2</sup>C
- 28 general purpose input/output (GPIO) pins
  - Port 0 – 8 bits
  - Port 1 – 8 bits with high current capability, regulated output voltage, and 5 V input tolerance
  - Port 2 – 8 bits
  - Port 3 – 4 bits
- Power
  - Internal power system enables operation from battery or external 2.7 to 3.6 V supply
  - Battery input voltage of 0.8 V to 3.6 V enables operation from single or dual series cells
  - Self adjusting power saving modes
- On-chip laser
  - Vertical cavity surface emitting laser (VCSEL) integrated within the sensor package
  - No calibration or alignment needed
  - Electrostatic discharge (ESD) immunity: 2000 V human body model (HBM)
  - Wavelength: 840 to 870 nm
  - IEC 60825-1 Class 1 safety: built-in eye-safe fault tolerant laser drive circuitry
- Snap-on lens
  - Molded optic: Self-aligning snap-on molded lens
  - 6 mm distance between the printed circuit board (PCB) and tracking surface

## Description

The CYONS2001 is a member of Cypress Semiconductor's second generation laser navigation system-on-chip (SoC) family of products. Powered by the high speed and high precision OptiCheck™ technology, along with the world leading PSoC technology, this family integrates the sensor, boost power regulator, and MCU functions into one chip. Bundled with the VCSEL into one package, the combination forms the market's first true mouse-on-a-chip solution.

The CYONS2001 is the version that is designed for general purpose wireless mouse applications. Enabled by the Cypress 0.13-micron mixed signal process technology, the device integrates the OptiCheck sensor with MCU into a single silicon chip that enables seamless communication between sensor and a wireless radio integrated circuit (IC). The sensor provides the best translation of precise hand motion into cursor motion on the PC.

This highly integrated solution is programmable. It provides mouse suppliers the ease-of-use to design a single PCB system and customize their product. With the VCSEL integrated in the same package, designers do not need to calibrate the laser power during the manufacturing process. This greatly increases production throughput and reduces manufacturing costs.

The innovative technology of OvationONS™ II provides high precision, high speed motion tracking, and low power consumption. Designers can select from a family of integration options, ranging from low power to high performance, to target different types of wired and wireless design applications.

The CYONS2001 solutions have a small form factor. Along with the lens, each package forms a complete and compact laser tracking system. This datasheet describes the detailed technology capabilities of the CYONS2001.

**Figure 1. CYONS2001/CYONSLENS2000 (2-Piece System)**

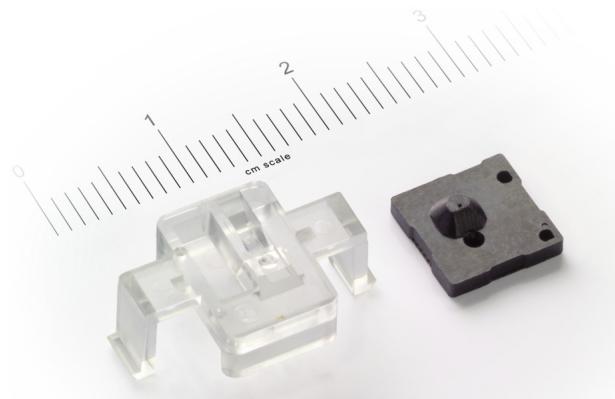

## Contents

<b>OvationONS II Family Performance Table</b> .....	<b>3</b>	DC Low Power Comparator Specifications .....	17
<b>OvationONS II Family Applications</b> .....	<b>3</b>	DC POR and LVD Specifications .....	17
<b>OvationONS II Family Functional Description</b> .....	<b>3</b>	DC Programming Specifications .....	18
<b>Pin Description</b> .....	<b>5</b>	AC Chip Level Specifications .....	19
<b>Microcontroller System</b> .....	<b>7</b>	AC General Purpose I/O Specifications .....	19
<b>Features</b> .....	<b>7</b>	AC External Clock Specifications .....	20
<b>PSoC Functional Overview</b> .....	<b>8</b>	AC Analog Mux Bus Specifications .....	20
The PSoC Core .....	8	AC Programming Specifications.....	20
The Analog Multiplexer System.....	8	AC SPI Specifications .....	21
Additional System Resources .....	8	AC Comparator Specifications .....	24
<b>Getting Started</b> .....	<b>8</b>	AC I2C Specifications.....	24
Application Notes .....	8	PCB Land Pads and Keepout Zones .....	25
Development Kits .....	8	Orientation of Axes.....	26
Training .....	8	PCB Mounting Height and Thickness.....	26
CYPros Consultants .....	8	Thermal Impedances .....	27
Solutions Library.....	8	Solder Reflow Peak Temperature .....	27
Technical Support .....	8	<b>Laser Safety Considerations</b> .....	<b>28</b>
<b>Development Tools</b> .....	<b>9</b>	Laser Output Power .....	28
PSoC Designer Software Subsystems.....	9	Laser Output Power Test Procedure.....	28
<b>Designing with PSoC Designer</b> .....	<b>10</b>	Registration Assistance.....	28
Select User Modules .....	10	<b>Development Tool Selection</b> .....	<b>29</b>
Configure User Modules.....	10	Software .....	29
Organize and Connect .....	10	Mouse Design Kits .....	29
Generate, Verify, and Debug.....	10	Development Kits .....	29
<b>Power Supply Connections</b> .....	<b>11</b>	Evaluation Tools.....	29
Overview .....	11	Device Programmers.....	30
Understanding DVDD.....	11	Third Party Tools .....	30
AVDD, VREGA, and VREGD .....	11	<b>Package Diagrams</b> .....	<b>31</b>
Using Battery Power.....	11	<b>Ordering Information</b> .....	<b>32</b>
Using External Power.....	11	Ordering Code Definition.....	32
Filtering and Grounding.....	11	<b>Document Conventions</b> .....	<b>33</b>
<b>Wireless Mouse Application Example</b> .....	<b>12</b>	Acronyms Used .....	33
<b>Electrical Specifications</b> .....	<b>13</b>	Units of Measure .....	33
Absolute Maximum Ratings.....	13	Numeric Naming.....	33
Operating Conditions.....	13	<b>Document History Page</b> .....	<b>34</b>
Power Consumption Specifications.....	14	<b>Sales, Solutions, and Legal Information</b> .....	<b>34</b>
Power Specifications .....	15	Worldwide Sales and Design Support.....	34
DC General Purpose I/O Specifications .....	16	Products .....	34
DC Analog Mux Bus Specifications.....	17	PSoC Solutions .....	34

## OvationONS II Family Performance Table

Parameter	CYONS2000	CYONS2001	CYONS2100	CYONS2101	CYONS2110	Unit
Variable resolution	400, 800, 1600	400, 800, 1600	400–3200	400–3200	400–3200	CPI
Maximum speed	30	30	75	75	75	in/s
Maximum acceleration	20	20	30	30	30	g
Integrated MCU	Yes	Yes	Yes	Yes	Yes	–
CapSense®	No	No	No	No	26 inputs	–
Flash	16	16	32	32	32	KB
SRAM	2	2	2	2	2	KB
Interfaces	Full-speed USB 4-wire SPI up to 28 GPIOs	4-wire SPI up to 28 GPIOs	Full-speed USB 4-wire SPI up to 28 GPIO	4-wire SPI up to 28 GPIOs	Full-speed USB 4-wire SPI up to 28 GPIOs	–
Battery supply voltage	NA	0.8 to 3.6	NA	0.8 to 3.6	0.8 to 3.6	V
USB supply voltage	4.25 to 5.25	NA	4.25 to 5.25	NA	4.25 to 5.25	V
External supply voltage	2.7 to 3.6	2.7 to 3.6	2.7 to 3.6	2.7 to 3.6	2.7 to 3.6	V
Zero motion	1	1	1	1	1	Count

## OvationONS II Family Applications

- Wired and wireless laser mice
  - Gaming, graphic design, desktop, and mobile mice
- Optical trackballs
- Battery powered devices
- Motion sensing applications

## OvationONS II Family Functional Description

The OvationONS II family is a two-piece laser navigation SoC kit containing the integrated IC package and the molded lens.

The 2-kV ESD-rated IC package integrates the VCSEL and laser sensor SoC. Depending on the product selected, the SoC includes an MCU, flash, SRAM, two internal oscillators, CapSense system, battery boost regulator, power regulator, and full-speed USB.

The molded lens collimates the VCSEL beam and images the light scattered from the tracking surface onto the sensor portion of the laser detector. The lens has features for registration to the package and easily snaps on to the PC board.

At the heart of the system is the OptiCheck laser navigation engine. It supports all functions required for tracking, including laser power control, resolution control, and self-adjusting power reduction, which reduces power consumption when motion stops. The laser output power is pre-calibrated to meet the eye safety requirements of IEC 60825 Class 1.

The navigation engine is accessed and controlled by an integrated PSoC-based MCU. The interface between the two blocks is through a system bus and a collection of navigation engine interrupts. Full details are available in the [OvationONS II Laser Navigation System-on-Chip TRM \(Technical Reference Manual\)](#) or in the PSoC Designer integrated development environment (IDE) software.

In addition to controlling the navigation engine, the PSoC MCU also serves as the main application processor. Based on Cypress's M8C architecture, the PSoC supports a rich instruction set, multiple processor speeds, and flexible GPIOs. Its IMO requires no external crystal. On-chip flash and RAM allow entire navigation systems to be implemented with the single SoC.

The OvationONS II family supports a wide range of powering options. Internal regulators minimize the need for external circuitry. Depending on the product selected, the device can be powered from a USB 5-V supply, from a single battery, from dual batteries, or from an external supply. The configuration and use of the power blocks are controlled with the integrated PSoC.

Wired sensors include integrated full-speed USB. As with the navigation engine and power system, the USB block is controlled by the integrated PSoC.

All sensors support a 4-wire SPI interface. A typical use of the SPI interface is to provide access to a radio for wireless applications. An I<sup>2</sup>C interface is also included with all devices.

The CYONS2110 device also supports CapSense functions, allowing additional features and differentiation in end products.

All features of the OvationONS II family are configured using Cypress's PSoC Designer™ software, allowing fast application development and time to market.

The OvationONS II family block diagram is shown on [Figure 2](#) on page 4. It shows a true SoC solution that enables design cycle reductions along with savings on manufacturing, PCB area, and component inventory management. The packaged solution delivers a fully integrated system that demonstrates tracking performance with efficient power consumption.

Figure 2. Block Diagram

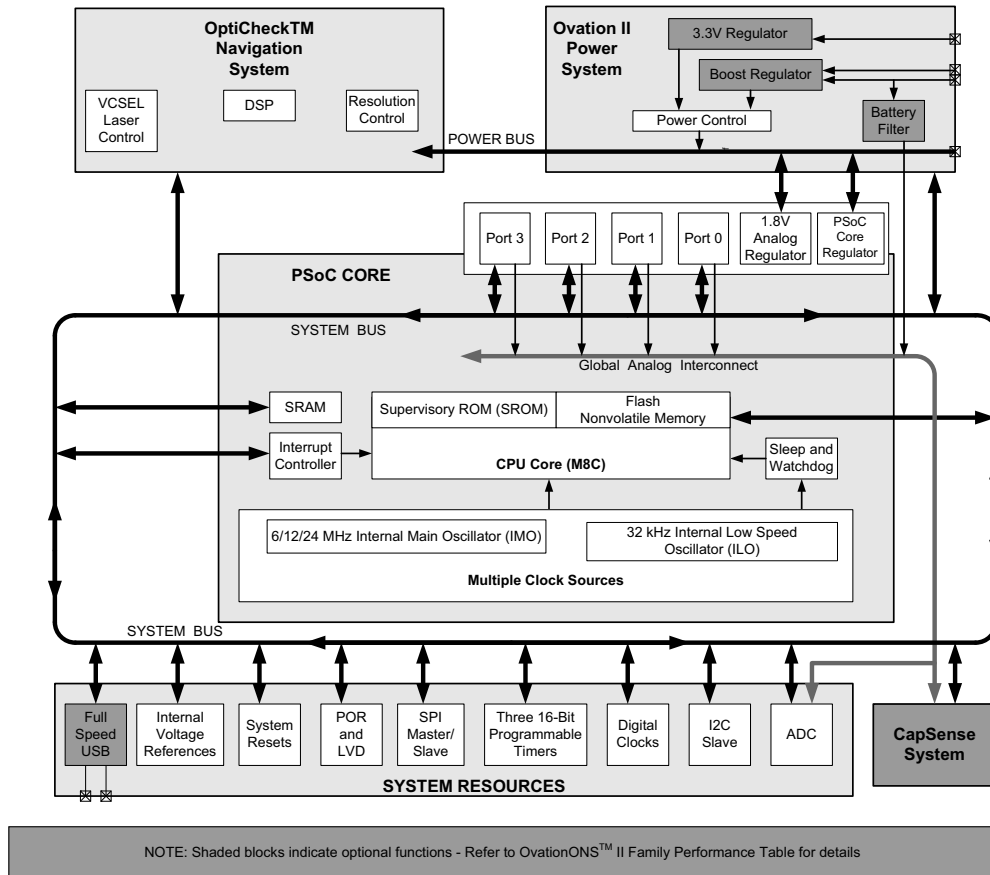

## Pin Description

This section describes, lists, and illustrates the CYONS2001 device pins and pinout configurations. The CYONS2001 is available in a 42-pin quad flat no-leads (QFN) package.

**Table 1. CYONS2001 Pin Description**

Pin	Name	Digital	Analog	Notes
1	XRES	I		Active high external reset with internal pull down
2	BOOST_GND	Power	Power	Boost regulator ground
3	BOOST_IND	Power	Power	Boost regulator inductor
4	VBATT	Power	Power	Boost regulator input
5	DVDD	Power	Power	Digital supply voltage and regulated output (see <a href="#">Power Supply Connections</a> on page 11)
6	VREGD	Power	Power	Digital VREG
7	AVDD	Power	Power	Analog supply voltage
8	VREGA	Power	Power	Analog VREG
9	P2[7]	I/O	I	GPIO port 2 pin 7
10	P1[5]	IOHR	I	SPI MISO, I2C_SDA, GPIO port 1 pin 5
11	P1[3]	IOHR	I	SPI CLK, GPIO port 1 pin 3
12	P2[3]	I/O	I	GPIO port 2 pin 3
13	P2[5]	I/O	I	GPIO port 2 pin 5
14	P1[7]	IOHR	I	SPI SS, I2C_SCL, GPIO port 1 pin 7
15	P1[1]	IOHR	I	SPI MOSI, ISSP CLK <sup>[1]</sup> , I2C_SCL, GPIO port 1 pin 1
16	P3[3]	IOHR	I	HCLK (OCD high speed clock output), GPIO port 3 pin 3
17	P1[0]	I/O	I	ISSP DATA <sup>[1]</sup> , I2C_SDA, GPIO port 1 pin 0
18	P3[5]	I/O	I	CCLK (OCD CPU clock output), GPIO port 3 pin 5
19	P1[6]	IOHR	I	GPIO port 1 pin 6
20	P1[2]	IOHR	I	GPIO port 1 pin 2
21	P2[2]	I/O	I	GPIO port 2 pin 2
22	P3[7]	I/O	I	OCDOE (OCD mode direction pin), GPIO port 3 pin 7
23	P3[1]	I/O	I	OCDO (OCD odd data output), GPIO port 3 pin 1
24	OCDE	OCD	OCD	OCDE (OCD even data output)
25	AVSS	Power	Power	Analog ground
26	P2[1]	I/O	I	GPIO port 2 pin 1
27	P2[0]	I/O	I	GPIO port 2 pin 0
28	P1[4]	IOHR	I	EXT CLK, GPIO port 1 pin 4
29	P2[4]	I/O	I	GPIO port 2 pin 4
30	DVSS	Power	Power	Digital ground
31	P2[6]	I/O	I	GPIO port 2 pin 6
32	P0[0]	I/O	I	GPIO port 0 pin 0
33	P0[2]	I/O	I	GPIO port 0 pin 2
34	P0[4]	I/O	I	GPIO port 0 pin 4
35	P0[6]	I/O	I	GPIO port 0 pin 6
36	P0[1]	I/O	I	GPIO port 0 pin 1

**Table 1. CYONS2001 Pin Description (continued)**

Pin	Name	Digital	Analog	Notes
37	P0[3]	I/O	I	GPIO port 0 pin 3
38	P0[5]	I/O	I	GPIO port 0 pin 5
39	P0[7]	I/O	I	GPIO port 0 pin 7
40	DNU			Do not use
41	DNU			Do not use
42	VPROG	Power		Power for ISSP
CP	DVSS	Power		Center pad (CP) must be connected to digital ground

Legend: I=Input; O=Output; H=5 mA High Output Drive, R=Regulated Output, OCD=On-Chip Debug

**Note**

- These are the in-system serial programming (ISSP) pins. Unlike other GPIOs, they are not high-impedance at power-on reset (POR). See the [Technical Reference Manual \(TRM\)](#) at [www.cypress.com](http://www.cypress.com) or in the PSoC Designer development software for more details.

Figure 3. Pin Diagram

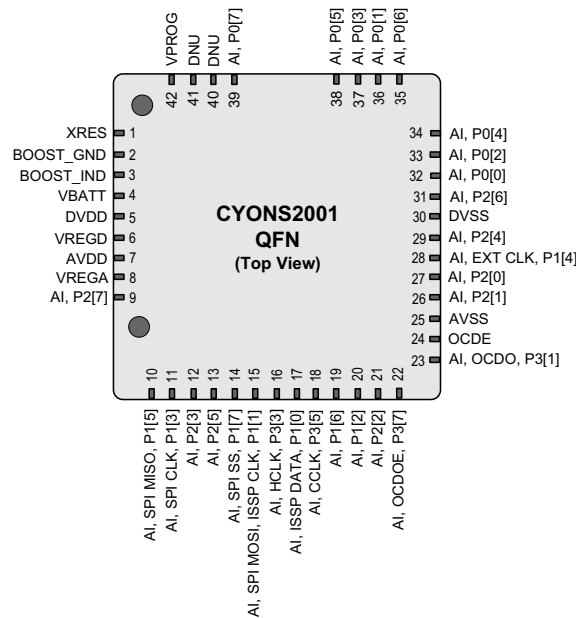

## Microcontroller System

### Features

- Powerful Harvard-architecture processor
  - M8C processor speed up to 24 MHz
  - Low power at high speed
  - Interrupt controller
  - Operating temperature range: +5 °C to +45 °C
- Flexible on-chip memory
  - 16 k flash program storage  
50,000 erase and write cycles
  - 2 KB SRAM data storage
  - Partial flash updates
  - Flexible protection modes
  - In-system serial programming (ISSP)
- Complete development tools
  - Free development tool (PSoC Designer™)
  - Full featured in-circuit emulator (ICE) and programmer
  - Full speed emulation
  - Complex breakpoint structure
  - 128 K trace memory
- Precision programmable clocking
  - Internal ±5.0% 6/12/24-MHz main oscillator
  - Internal 32-kHz low speed oscillator
  - Support for optional external 32-kHz crystal
- Programmable pin configurations
  - 25-mA sink current on all GPIOs
  - Pull-up, high-Z, open drain, or strong drive modes on all GPIOs
  - Up to 28 analog inputs on GPIO
  - Configurable inputs on all GPIOs
  - Selectable, regulated digital I/O on port 1
    - 3.3-, 2.5-, or 1.8-V output
  - 3.0 V, 20 mA total port 1 source current
  - 5-mA source current mode on ports 0 and 1
  - Hot swap capable
- Versatile analog mux
  - Common internal analog bus
  - Simultaneous connection of I/O combinations
  - High power supply rejection ratio (PSRR) comparator
  - Low dropout voltage regulator for the analog array
- Additional system resources
  - SPI master and SPI slave
    - Clock speed up to 12 MHz
  - Three 16-bit timers
  - Watchdog and sleep timers
  - Internal voltage reference
  - Integrated supervisory circuit
  - Analog-to-digital converter (ADC)
  - I<sup>2</sup>C slave

## PSoC Functional Overview

Cypress's programmable system-on-chip (PSoC) on-chip controllers combine dynamic, configurable analog and digital blocks and an 8-bit MCU on a single chip, replacing multiple discrete components while delivering advanced flexibility and functionality. A PSoC device includes configurable analog and digital blocks, and programmable interconnect. This architecture can create customized peripheral configurations to match the requirements of each individual application. Additionally, a fast CPU, flash program memory, SRAM data memory, and configurable I/O are included in a range of convenient pinouts.

The architecture for this device family, as illustrated in [Figure 2](#) on page 4, contains: the core, the navigation sensor, the power system, and the system resources. A common, versatile bus enables connection between I/O and the analog system. GPIO, which provides access to the MCU and analog mux, is also included.

### The PSoC Core

The PSoC core is a powerful engine that supports a rich instruction set. The PSoC core encompasses SRAM for data storage, an interrupt controller, sleep and watchdog timers, an IMO, and an Internal Low Speed Oscillator ILO. The CPU core, called the M8C, is a powerful processor with speeds up to 24 MHz. The M8C is a 4 million instructions per second (MIPS) 8-bit Harvard architecture microprocessor.

System resources provide additional capability, such as configurable USB and SPI master-slave communication interface, three 16-bit programmable timers, and various system resets supported by the M8C.

### The Analog Multiplexer System

The analog mux bus connects to every GPIO pin. Pins are connected to the bus individually or in any combination. Analog signals may be routed to an internal ADC.

Other multiplexer applications include:

- Chip-wide mux that enables analog input from any I/O pin
- Crosspoint connection between any I/O pin combinations

### Additional System Resources

System resources, some previously listed, provide additional capability useful to complete systems. Additional resources include low voltage detection and power on reset. The following statements describe the merits of each system resource:

- The SPI master/slave module
  - Provides communication over three or four wires
  - Runs at speeds of 46.9 kHz to 3 MHz (lower for a slower system clock).
- An I<sup>2</sup>C slave module
- Low voltage detection (LVD) interrupts can signal the application of falling voltage levels, while the advanced POR circuit eliminates the need for a system supervisor.
- An internal reference provides an absolute reference for capacitive sensing.

## Getting Started

For in depth information, along with detailed programming details, see the *PSoC<sup>®</sup> Technical Reference Manual*.

For up-to-date ordering, packaging, and electrical specification information, see the latest [PSoC device datasheets](#) on the web.

### Application Notes

[Cypress application notes](#) are an excellent introduction to the wide variety of possible PSoC designs.

### Development Kits

[PSoC Development Kits](#) are available online from and through a growing number of regional and global distributors, which include Arrow, Avnet, Digi-Key, Farnell, Future Electronics, and Newark.

### Training

[Free PSoC technical training](#) (on demand, webinars, and workshops), which is available online via [www.cypress.com](http://www.cypress.com), covers a wide variety of topics and skill levels to assist you in your designs.

### CYPros Consultants

Certified PSoC Consultants offer everything from technical assistance to completed PSoC designs. To contact or become a PSoC Consultant go to the [CYPros Consultants](#) web site.

### Solutions Library

Visit our growing [library of solution focused designs](#). Here you can find various application designs that include firmware and hardware design files that enable you to complete your designs quickly.

### Technical Support

[Technical support](#) – including a searchable Knowledge Base articles and technical forums – is also available online. If you cannot find an answer to your question, call our Technical Support hotline at 1-800-541-4736.



## Development Tools

PSoC Designer™ is the revolutionary Integrated Design Environment (IDE) that you can use to customize PSoC to meet your specific application requirements. PSoC Designer software accelerates system design and time-to-market. Develop your applications using a library of precharacterized analog and digital peripherals (called User Modules) in a drag-and-drop design environment. Then, customize your design by leveraging the dynamically generated application programming interface (API) libraries of code. Finally, debug and test your designs with the integrated debug environment including in-circuit emulation (ICE) and standard software debug features. PSoC Designer includes:

- Application Editor GUI for device and [User Module](#) configuration and dynamic reconfiguration
- Extensive [User Module](#) catalog
- Integrated source code editor (C and Assembly)
- Free C compiler with no size restrictions or time limits
- Built in debugger
- Integrated Circuit Emulation (ICE)
- Built-in Support for Communication Interfaces:
  - Hardware and software I<sup>2</sup>C slaves and masters
  - Full-speed USB 2.0
  - Up to 4 full-duplex UARTs, SPI master and slave, and Wireless

PSoC Designer supports the entire library of PSoC 1 devices and runs on Windows XP, Windows Vista, and Windows 7.

### PSoC Designer Software Subsystems

#### *Design Entry*

In the chip-level view you choose a base device to work with and then select different onboard analog and digital components called user modules that use the PSoC blocks. Examples of user modules are ADCs, DACs, amplifiers, and filters. You configure the user modules for your chosen application and connect them to each other and to the proper pins. Then you generate your project. This prepopulates your project with APIs and libraries that you can use to program your application.

The tool also supports easy development of multiple configurations and dynamic reconfiguration. Dynamic reconfiguration allows for changing configurations at run time. In essence, this allows you to use more than 100% of PSoC's resources for a given application.

#### *Code Generation Tools*

The code generation tools work seamlessly within the PSoC Designer interface and have been tested with a full

range of debugging tools. You can develop your design in C, assembly, or a combination of the two - the choice is yours.

**Assemblers.** The assemblers allow you to merge assembly code seamlessly with C code. Link libraries automatically use absolute addressing or are compiled in relative mode, and linked with other software modules to get absolute addressing.

**C Language Compilers.** C language compilers are available that support the PSoC family of devices. The products allow you to create complete C programs for the PSoC family devices. The optimizing C compilers provide all the features of C tailored to the PSoC architecture. They come complete with embedded libraries providing port and bus operations, standard keypad and display support, and extended math functionality.

#### *Debugger*

PSoC Designer has a debug environment that provides hardware in-circuit emulation (ICE), allowing you to test the program in a physical system while providing an internal view of the PSoC device. Debugger commands allow a designer to read and program and read and write data memory, read and write I/O registers, read and write CPU registers, set and clear break-points, and provide program run, halt, and step control. The debugger also allows the designer to create a trace buffer of registers and memory locations of interest.

#### *Online Help System*

The online help system displays online, context-sensitive help. Designed for procedural and quick reference, each functional subsystem has its own context-sensitive help. This system also provides tutorials and links to FAQs and an Online Support Forum to aid the designer.

#### *In-Circuit Emulator*

A low cost, high functionality In-Circuit Emulator (ICE) is available for development support. This hardware has the capability to program single devices.

The emulator consists of a base unit that connects to the PC using a USB port. The base unit is universal and operates with all PSoC devices. Emulation pods for each device family are available separately. The emulation pod takes the place of the PSoC device in the target board and performs full speed (24 MHz) operation.

## Designing with PSoC Designer

The development process for the PSoC® device differs from that of a traditional fixed function microprocessor. The configurable analog and digital hardware blocks give the PSoC architecture a unique flexibility that pays dividends in managing specification change during development and by lowering inventory costs. These configurable resources, called PSoC Blocks, have the ability to implement a wide variety of user-selectable functions. The PSoC development process is summarized in four steps:

1. Select [User Modules](#).
2. Configure user modules.
3. Organize and connect.
4. Generate, verify, and debug.

### Select User Modules

PSoC Designer provides a library of prebuilt, pretested hardware peripheral components called “user modules.” User modules make selecting and implementing peripheral devices, both analog and digital, simple.

### Configure User Modules

Each user module that you select establishes the basic register settings that implement the selected function. They also provide parameters and properties that allow you to tailor their precise configuration to your particular application. For example, a pulse width modulator (PWM) User Module configures one or more digital PSoC blocks, one for each 8 bits of resolution. The user module parameters permit you to establish the pulse width and duty cycle. Configure the parameters and properties to correspond to your chosen application. Enter values directly or by selecting values from drop-down menus. All the user modules are documented in datasheets that may be viewed directly in PSoC Designer or on the Cypress website. These [user module datasheets](#) explain the internal operation of the user module and provide performance specifications. Each datasheet describes

the use of each user module parameter, and other information you may need to successfully implement your design.

### Organize and Connect

You build signal chains at the chip level by interconnecting user modules to each other and the I/O pins. You perform the selection, configuration, and routing so that you have complete control over all on-chip resources.

### Generate, Verify, and Debug

When you are ready to test the hardware configuration or move on to developing code for the project, you perform the “Generate Configuration Files” step. This causes PSoC Designer to generate source code that automatically configures the device to your specification and provides the software for the system. The generated code provides APIs with high-level functions to control and respond to hardware events at run time and interrupt service routines that you can adapt as needed.

A complete code development environment allows you to develop and customize your applications in either C, assembly language, or both.

The last step in the development process takes place inside PSoC Designer’s debugger (access by clicking the Connect icon). PSoC Designer downloads the HEX image to the ICE where it runs at full speed. PSoC Designer debugging capabilities rival those of systems costing many times more. In addition to traditional single-step, run-to-breakpoint and watch-variable features, the debug interface provides a large trace buffer and allows you to define complex breakpoint events that include monitoring address and data bus values, memory locations and external signals.

## Power Supply Connections

Figure 4. Power Connections

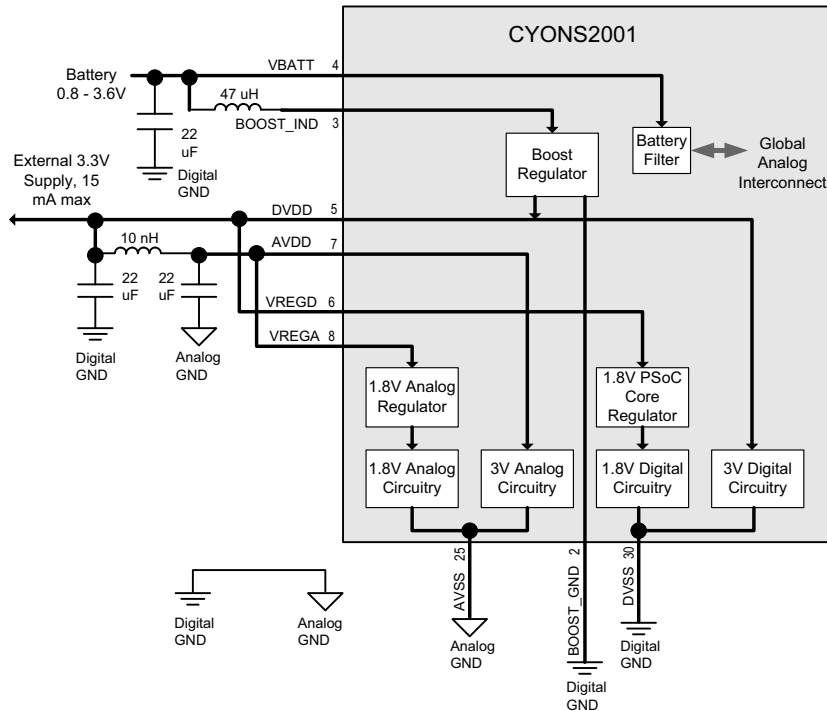

### Overview

The CYONS2001 incorporates a powerful and flexible powering system. It can be powered from one of two sources: a battery (one cell or two cells in series) or an external 3.3-V supply. Additionally, the CYONS2001's internal regulators can supply current to external devices. This section describes the capabilities and usage of the power system. Refer to Figure 4 for a block diagram of the CYONS2001's power system.

### Understanding DVDD

DVDD is a unique pin that can serve as either an input or an output. When the device is powered from a battery (using the boost regulator), DVDD acts as an output, providing a 3.3-V voltage that can be used to power AVDD, VREGD, VREGA, and external parts. When the device is powered from an external 3.3-V supply, DVDD acts as an input only.

### AVDD, VREGA, and VREGD

As with DVDD, these signals power the internal circuitry of the device. Unlike DVDD, these are always inputs. They should be connected as shown in Figure 4.

### Using Battery Power

For wireless applications, the device may be powered by the boost regulator. In this configuration, BOOST\_GND should be connected to DVSS, BOOST\_IND, and VBATT pins should be

connected as shown in Figure 4. Do not run the device without the appropriate bypass capacitors, or excessive voltage may be generated across the inductor.

VBATT connects to an internal low pass filter. The filter output can be routed through the global analog interconnect to the device's ADC, enabling the battery voltage to be monitored.

For designs using two series batteries, an option is to drive VREGA directly from the battery output. Doing so reduces the conversion loss in the boost regulator. However, care must be taken to ensure that the battery voltage does not fall below 1.71 V.

### Using External Power

The CYONS2001 can also be powered from an external source. In this case, BOOST\_GND should be connected to DVSS, VDD5V, and BOOST\_IND should be left unconnected, and the external 3.3-V source should connect to DVDD. VBATT can be connected to DVSS or left unconnected.

### Filtering and Grounding

For all designs, it is important to provide proper grounding and proper isolation between the analog and digital power supplies. The analog and digital grounds should be isolated, except for a single connection point that is placed very close to the device. On the supply side, a L-C filter should be placed between AVDD and DVDD, as shown in Figure 4.

## Wireless Mouse Application Example

Figure 5 shows an implementation of a wireless mouse.

Figure 5. Wireless Mouse

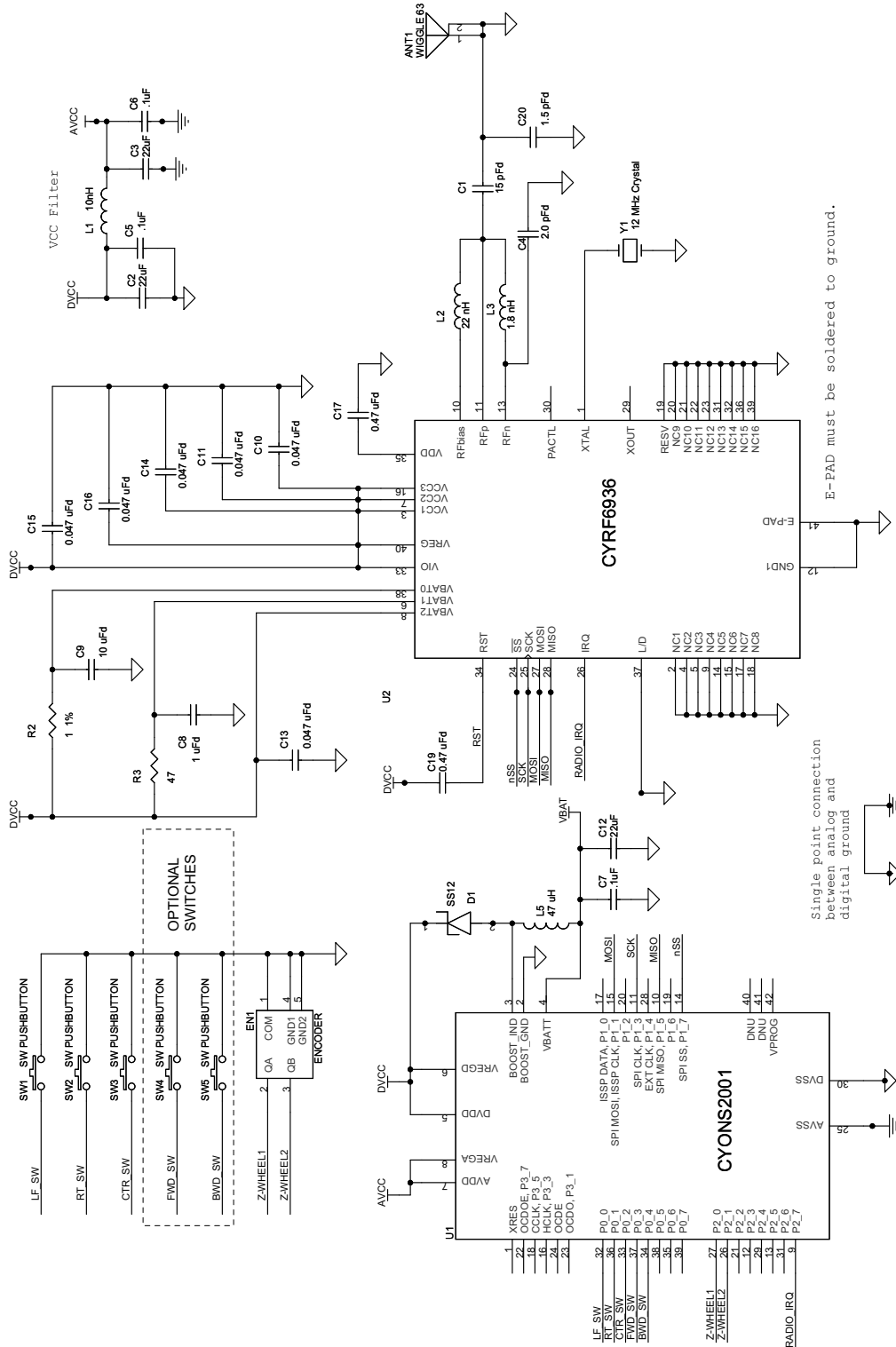

## Electrical Specifications

This section presents the DC and AC electrical specifications of the CYONS2001 device. For the most up-to-date electrical specifications, confirm that you have the most recent datasheet by visiting <http://www.cypress.com>.

### Absolute Maximum Ratings

Parameter	Min	Typ	Max	Unit	Conditions
Storage temperature <sup>[2]</sup>	-40	25	65	°C	Case temperature
Operating temperature	-15	-	55	°C	Case temperature
Lead solder temperature		-	260	°C	10 seconds
Supply voltage, DVDD, AVDD, VREGA, and VREGD relative to DVSS)	-	-	3.6	V	
Supply voltage, VBATT relative to DVSS	-	-	3.6	V	
Electrostatic discharge (ESD)	-	-	2.0	kV	All pins, HBM MIL 883 method 3015
I/O voltage relative to DVSS	-0.5		DVDD + 0.5	V	GPIO ports 0, 2, and 3
I/O voltage relative to DVSS	-	-	5.5	V	GPIO port 1
Latch up current	-	-	100	mA	
Maximum current into any GPIO pin	-25	-	+50	mA	

### Operating Conditions

Parameter	Min	Typ	Max	Unit	Conditions
Operating temperature	5	-	45	°C	
Power supply voltage DVDD, AVDD, VREGD VREGA VBATT	2.70 1.71 0.80	-	3.60 3.60 3.60	V	
Power supply rise time	100	-	-	µs	
Supply noise - AVDD (sinusoidal)	-	-	25	mV pp	10 kHz to 50 MHz
Supply noise - V <sub>DD</sub> , DVDD (sinusoidal)	-	-	100	mV pp	10 kHz to 50 MHz
Distance from PCB to tracking surface	5.80	6	6.20	mm	See <a href="#">Figure 15</a> on page 25
PCB thickness	1.54		1.79	mm	See <a href="#">Figure 15</a> on page 25

#### Note

- High storage temperature reduces flash data retention time specified in [Table 7](#) on page 18. Recommended storage temperature is 25 ± 25 °C. Extended duration above 65 °C can degrade reliability.

## Power Consumption Specifications

### Introduction

As described in [Overview](#) on page 11, the CYONS2001 has a highly advanced power system, which can be used to develop very low power applications. This section describes and specifies the power consumption performance of the device.

### Enabling Low-Power Modes

In some cases, designers may want to develop “always-on” applications, with no power-saving modes and consequently no wakeup latency in performance. In other applications, conserving power is crucial, and power-saving modes are a firm requirement. The CYONS2001 allows low power modes to be enabled or disabled in firmware, either through register writes or through the API in Cypress’s PSoC Designer development software. The remainder of this section applies to applications requiring power saving modes.

### Operating Modes

From a power consumption standpoint, consider these three operating modes:

- **Tracking mode:** In this mode, the device is actively tracking on a surface. It is the highest power mode of the device. The current consumption has a slight dependence on speed and surface. The current, however, is independent of resolution.
- **Inactive mode:** In this mode, the device is in its lowest power state. In inactive mode, the device cannot sense motion, but a timer is running. The timer can generate an interrupt that can wake the rest of the device and start tracking motion.
- **Sleep modes:** In sleep modes, the device self-transitions between tracking mode and inactive mode. The typical use of sleep modes is when the device is at rest, but might still be moved. In sleep modes, the CYONS2001 stays in inactive mode for a fixed time, then wake up and check for motion. If motion is detected, the device fully wakes up and begins tracking. If no motion is detected, the device can go back to sleep mode.

### Power Management Through Sleep Mode Control

Power management for the CYONS2001 consists of setting the parameters that define the sleep modes. The device is equipped

with four sets of sleep mode settings, enabling four levels of sleep. By controlling the parameters of these four sleep modes, the designer can tailor the solution to make appropriate tradeoffs between power consumption and wakeup latency.

The transition between sleep modes is under the control of the CYONS2001’s digital signal processor (DSP) – no firmware needs to be written to manage the transition between modes.

Each of the four available sleep modes is defined by three parameters. These parameters are defined as registers that can be controlled by firmware, either through direct register writes or by using the NAV User Module in PSoC Designer.

- **Sleep time:** This is the amount of time that the device is in its low power inactive state.
- **Motion threshold:** This is the amount of motion required to bring the device out of sleep.
- **Sleep mode time:** This is the amount of time the device stays in a particular sleep mode before transitioning to the next lowest sleep mode. Longer sleep times save power but have higher wakeup latency.

[Figure 6](#) shows the flowchart for a particular sleep mode, showing how the three parameters affect behavior.

### Calculating Power for Sleep Mode

The power consumption in sleep mode can be found by using a duty cycle calculation. The sleep mode current is determined by the tracking mode current, the inactive current, the time required to check for motion (typically 2.9 ms), and the time between check-for-motion events. The expected current consumption is given by the formula

$$I_{SLEEP} = \frac{I_{TRACK} \times 2.9 + I_{INACT} \times T_{SLEEP}}{2.9 + T_{SLEEP}}$$

where  $I_{SLEEP}$  is the sleep current,  $I_{TRACK}$  is the tracking current,  $I_{INACT}$  is the inactive current, and  $T_{SLEEP}$  is the time (in ms) in the low power state. For example, if the tracking current is 8.5 mA, the inactive current is 7.5  $\mu$ A and the sleep time is 100 ms, then the expected sleep current is 0.25 mA.

**Figure 6. Sleep Mode Flowchart**

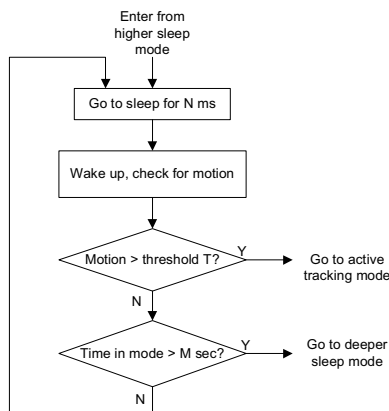

## Power Specifications

There are two ways to power the CYONS2001: external powering and battery powering. [Table 4](#) provides the current consumption values for each mode.

With external powering, a 3-V supply is connected to DVDD, AVDD, VREGD, and VREGA, and the internal regulator is turned off. In this case, the current consumption during tracking is  $I_{\text{TRACK\_EXT}}$ , and the consumption during sleep is  $I_{\text{SLEEP}}$ .

With battery powering, the device is powered by the internal boost regulator. Total tracking current must include the current consumed by the regulator itself, and is given by the sum of  $I_{\text{TRACK}}$  and  $I_{\text{REGBOOST}}$ . Similarly, sleep current is given by the

sum of  $I_{\text{SLEEP}}$  and  $I_{\text{REGBOOST}}$ . In both cases, the current drawn from the battery must be adjusted by the voltage conversion ratio and the boost regulator efficiency  $\eta_{\text{TRACK}}$  and  $\eta_{\text{INACT}}$ .

Sleep current is achieved by activating “Navigation Sleep Modes” in Cypress’s PSoC Designer development environment. Doing so enables the sleep mode progressions described in [Operating Modes](#) on page 14. If sleep modes are not activated, the device current stays at tracking levels, even when the device is not sensing motion.

$I_{\text{SB}}$  is the current in the lowest-power mode of the device. In this mode, the CPU is halted and operation can only be restarted with an external reset at the XRES pin.

**Table 2. Power Specifications**

Symbol	Description	Conditions	Min	Typ	Max	Units
$I_{\text{TRACK}}$	Tracking current into DVDD, AVDD, VREGD, VREGA	3.0 V, 25 °C, 5 in/s, 6 MHz IMO, 6 MHz CPU clock, white surface, nominal tracking height	–	6	9.5	mA
$I_{\text{INACT}}$	Inactive current into DVDD, AVDD, VREGD, VREGA	3.0 V, 25 °C, CPU in sleep state	–	7	14	μA
$I_{\text{SLEEP}}$	Sleep current into DVDD, AVDD, VREGD, VREGA	3.0 V, 25 °C	See <a href="#">Calculating Power for Sleep Mode</a> on page 14 for equation			
$I_{\text{REGBOOST}}$	Boost regulator current consumption	3.0 V at VBATT, 25 °C	–	20	–	μA
$\eta_{\text{TRACK}}$	Boost converter efficiency, tracking mode	1.2 V VBATT input, 47 μH inductor, 10 mA load, 400 kHz switching frequency	–	90	–	%
$\eta_{\text{INACT}}$	Boost converter efficiency, inactive mode	1.2 V VBATT input, 47 μH inductor	–	70	–	%
$V_{\text{BOOST\_SET}}$	Boost converter nominal output	Programmed using PSoC Designer user module calibration feature	2.7	–	3.3	V
$V_{\text{BOOST}}^{[3]}$	Boost converter accuracy	Offset from set point	–10	–	+10	%
$I_{\text{SB}}$	Shutdown current into DVDD, AVDD, VREGD, VREGA, all blocks off	3.0 V, 25 °C	–	4	11	μA

**Note**

3. Boost output specification requires use of calibrated user module in PSoC Designer version 5.0 Service Pack 6 or later.

**DC General Purpose I/O Specifications**

GPIOs are arranged into four ports. Ports 0, 1, and 2 have eight GPIO pins and Port 3 has four GPIO pins. Port 1 has an optional low drop out (LDO) regulator that adjusts the port's output voltage to 1.8, 2.5, or 3.0 V. Additionally, each GPIO pin can be independently set to one of four drive modes: strong drive, open drain, pullup, or high-Z analog.

Rise and fall times are specified for 10% and 90% voltage values.

The following tables list guaranteed maximum and minimum specifications for the voltage range of 2.7 V to 3.6 V at the DVDD pin, and over the temperature range  $5\text{ }^{\circ}\text{C} \leq T_A \leq 45\text{ }^{\circ}\text{C}$ . Typical parameters apply to 3.3 V at 25 °C and are for design guidance only.

**Table 3. 2.7 V to 3.6 V DC GPIO Specifications**

Symbol	Description	Conditions	Min	Typ	Max	Units
R <sub>PU</sub>	Pull up resistor	Pin configured for pullup mode.	4.0	5.6	8.0	kΩ
V <sub>OH1</sub>	High output voltage Port 2 or 3 pins	I <sub>OH</sub> ≤ 10 μA, maximum of 10 mA source current in all I/Os.	DVDD 0.2	–	–	V
V <sub>OH2</sub>	High output voltage Port 2 or 3 pins	I <sub>OH</sub> = 1 mA, maximum of 20 mA source current in all I/Os.	DVDD 0.9	–	–	V
V <sub>OH3</sub>	High output voltage Port 0 or 1 pins with LDO regulator disabled for Port 1	I <sub>OH</sub> < 10 μA, maximum of 10 mA source current in all I/Os.	DVDD 0.2	–	–	V
V <sub>OH4</sub>	High output voltage Port 0 or 1 Pins with LDO regulator disabled for Port 1	I <sub>OH</sub> = 5 mA, maximum of 20 mA source current in all I/Os.	DVDD 0.9	–	–	V
V <sub>OH5</sub>	High output voltage Port 1 pins with LDO regulator enabled for 3 V out	I <sub>OH</sub> < 10 μA, DVDD > 3.1 V, maximum of 4 I/Os all sourcing 5 mA.	2.85	3.00	3.30	V
V <sub>OH6</sub>	High output voltage Port 1 Pins with LDO Regulator Enabled for 3 V Out	I <sub>OH</sub> = 5 mA, DVDD > 3.1 V, maximum of 20 mA source current in all I/Os.	2.20	–	–	V
V <sub>OH7</sub>	High output voltage Port 1 pins with LDO enabled for 2.5 V out	I <sub>OH</sub> < 10 μA, DVDD > 2.7 V, maximum of 20 mA source current in all I/Os.	2.35	2.50	2.75	V
V <sub>OH8</sub>	High output voltage Port 1 pins with LDO enabled for 2.5 V out	I <sub>OH</sub> = 2 mA, DVDD > 2.7 V, maximum of 20 mA source current in all I/Os.	1.90	–	–	V
V <sub>OH9</sub>	High output voltage Port 1 pins with LDO enabled for 1.8 V out	I <sub>OH</sub> < 10 μA, DVDD > 2.7 V, maximum of 20 mA source current in all I/Os.	1.60	1.80	2.10	V
V <sub>OH10</sub>	High output voltage Port 1 pins with LDO enabled for 1.8 V out	I <sub>OH</sub> = 1 mA, DVDD > 2.7 V, maximum of 20 mA source current in all I/Os.	1.20	–	–	V
V <sub>OL</sub>	Low output voltage	I <sub>OL</sub> = 25 mA, DVDD > 3.3 V, maximum of 60 mA sink current on even port pins (for example, P0[2] and P1[4]) and 60 mA sink current on odd port pins (for example, P0[3] and P1[5]).	–	–	0.75	V
V <sub>IL</sub>	Input low voltage		–	–	0.80	V
V <sub>IH</sub>	Input high voltage		2.00	–		V
V <sub>H</sub>	Input hysteresis voltage		–	80	–	mV
I <sub>IL</sub>	Input leakage (absolute value)	Gross tested to 1 μA.	–	0.5	1.0	μA
C <sub>PIN</sub>	Pin capacitance	Temp = 25 °C.	0.5	1.7	8.0	pF



### DC Analog Mux Bus Specifications

The analog mux bus can connect signals from GPIOs to and from internal analog blocks and other GPIOs. [Table 4](#) lists guaranteed maximum and minimum specifications for the entire voltage and temperature ranges.

**Table 4. DC Analog Mux Bus Specifications**

Parameter	Description	Conditions	Min	Typ	Max	Unit
R <sub>SW</sub>	Switch resistance to common analog bus	Pin voltage < 1.8 V	–	–	800	Ω
R <sub>GND</sub>	Resistance of initialization switch to DVSS	Pin voltage < 1.8 V	–	–	800	Ω

### DC Low Power Comparator Specifications

The device includes two general purpose comparators, using internal or external signals from the analog mux bus. [Table 5](#) lists guaranteed maximum and minimum specifications for the entire voltage and temperature ranges.

**Table 5. DC Comparator Specifications**

Parameter	Description	Conditions	Min	Typ	Max	Unit
V <sub>LPC</sub>	Low power comparator (LPC) common mode	Maximum voltage limited to DVDD.	0.0	–	1.8	V
I <sub>LPC</sub>	LPC supply current		–	10	40	μA
V <sub>OSLPC</sub>	LPC voltage offset		–	2.5	30	mV

### DC POR and LVD Specifications

The device features two mechanisms for dealing with low power supply voltages. Both POR and LVD events occur when DVDD falls below a threshold. A POR completely resets the device. An LVD generates an interrupt to the MCU, allowing the application developer to better manage power supply drops.

The POR threshold is defined by bits 7 (HPOR) and 5:4 (PORLEV) and of the VLT\_CR register at address E3h in register bank 1. The LVD threshold is defined by bits 2:0 (VM) of the same register. Refer to the [technical reference manual](#) for more details.

[Table 6](#) lists guaranteed maximum and minimum specifications for the entire voltage and temperature ranges.

**Table 6. DC POR and LVD Specifications**

Parameter	Description	Conditions	Min	Typ	Max	Unit
V <sub>POR0</sub>	DVDD Value for POR trip PORLEV[1:0] = 00b, HPOR = 0	DVDD must be greater than or equal to 1.71 V during startup, reset from the XRES pin, or reset from watchdog.	1.61	1.66	1.71	V
V <sub>POR1</sub>	PORLEV[1:0] = 00b, HPOR = 1		–	2.36	2.40	V
V <sub>POR2</sub>	PORLEV[1:0] = 01b, HPOR = 1		–	2.60	2.65	V
V <sub>POR3</sub>	PORLEV[1:0] = 10b, HPOR = 1		–	2.82	2.95	V
V <sub>LVD0</sub>	DVDD Value for LVD trip VM[2:0] = 000b		2.40 <sup>[4]</sup>	2.45	2.51	V
V <sub>LVD1</sub>	VM[2:0] = 001b		2.64 <sup>[5]</sup>	2.71	2.78	V
V <sub>LVD2</sub>	VM[2:0] = 010b		2.85 <sup>[6]</sup>	2.92	2.99	V
V <sub>LVD3</sub>	VM[2:0] = 011b		2.95	3.02	3.09	V
V <sub>LVD4</sub>	VM[2:0] = 100b		3.06	3.13	3.20	V
V <sub>LVD5</sub>	VM[2:0] = 101b		1.84	1.90	1.96	V
V <sub>LVD6</sub>	VM[2:0] = 110b		1.75 <sup>[7]</sup>	1.80	1.84	V

**Notes**

4. Always greater than 50 mV above V<sub>POR1</sub> voltage for falling supply.
5. Always greater than 50 mV above V<sub>POR2</sub> voltage for falling supply.
6. Always greater than 50 mV above V<sub>POR3</sub> voltage for falling supply.
7. Always greater than 50 mV above V<sub>POR0</sub> voltage for falling supply.

## DC Programming Specifications

Table 7 lists guaranteed maximum and minimum specifications for the entire voltage and temperature ranges.

The CYONS2001 must be properly powered for flash programming, with DVDD, AVDD, VREGD, and VREGA all held within the specified range. A suitable option for power is to apply +5 V to VPROG, and to connect DVDD, AVDD, VREGD, and VREGA together. In this option, there is no need to provide external power to the DVDD/AVDD/VREGD/VREGA node. If VPROG is not used, the designer must include provisions for supplying DVDD, AVDD, VREGD, and VREGA externally.

**Table 7. DC Programming Specifications**

Parameter	Description	Conditions	Min	Typ	Max	Unit
V <sub>5VPROG</sub>	Programming power for VPROG		4.75	5.0	5.25	V
I <sub>5VPROG</sub>	VPROG current for programming		–	–	25	mA
V <sub>IW</sub>	Supply voltage for flash write operations	V <sub>IW</sub> applied to DVDD, AVDD, VREGD, and VREGA	2.7	–	3.6	V
I <sub>DDP</sub>	Supply current during programming or verify		–	5	25	mA
V <sub>ILP</sub>	Input low voltage during programming or verify	See <a href="#">DC General Purpose I/O Specifications</a> on page 16.	–	–	V <sub>IL</sub>	V
V <sub>IHP</sub>	Input high voltage during programming or verify	See <a href="#">DC General Purpose I/O Specifications</a> on page 16.	V <sub>IH</sub>	–	–	V
I <sub>ILP</sub>	Input current when applying V <sub>ILP</sub> to ISSP CLK and ISSP DATA pins during programming or verify	Driving internal pull down resistor.	–	–	0.2	mA
I <sub>IHP</sub>	Input current when applying V <sub>IHP</sub> to ISSP CLK and ISSP DATA pins during programming or verify	Driving internal pull down resistor.	–	–	1.5	mA
V <sub>OLP</sub>	Output low voltage during programming or verify		–	–	DVSS + 0.75	V
V <sub>OHP</sub>	Output high voltage during programming or verify	<a href="#">DC General Purpose I/O Specifications</a> on page 16. For DVDD > 3 V use the value with I <sub>OH</sub> = 5 mA.	V <sub>OH</sub>	–	DVDD	V
Flash <sub>ENPB</sub>	Flash write endurance	Erase/write cycles by block.	50,000	–	–	Cycles
Flash <sub>DR</sub>	Flash data retention	Following maximum flash write cycles at ambient temp of 45 °C	5	10	–	Years

## AC Chip Level Specifications

The device has two internal oscillators. The IMO controls the clock speeds for the CPU. A programmable frequency divider allows the CPU to run at lower speeds than the IMO. The ILO is typically active in sleep modes, clocking sleep and or watchdog timers. Other internal timers can be clocked by either the CPU clock or the ILO.

Table 8 lists guaranteed maximum and minimum specifications for the entire voltage and temperature ranges.

**Table 8. AC Chip Level Specifications**

Parameter	Description	Min	Typ	Max	Unit
F <sub>IMO24</sub>	IMO frequency for 24-MHz setting	22.8	24	25.2	MHz
F <sub>IMO12</sub>	IMO frequency for 12-MHz setting	11.4	12	12.6	MHz
F <sub>IMO6</sub>	IMO frequency for 6-MHz setting	5.7	6.0	6.3	MHz
DC <sub>IMO</sub>	IMO output duty cycle at 6 and 12 MHz setting <sup>[8]</sup>	40	50	60	%
F <sub>CPU</sub>	CPU frequency <sup>[9]</sup>	F <sub>IMO</sub> / 256	–	F <sub>IMO</sub>	MHz
F <sub>32K1</sub>	ILO frequency <sup>[10]</sup>	19	32	50	kHz
T <sub>RAMP</sub>	Supply ramp time	20	–	–	μs
TXRST	External reset pulse width at power-up	1	–	–	ms
TXRST2	External reset pulse width after power-up	10	–	–	μs
TMOT	Motion delay from reset to valid tracking data <sup>[11]</sup>	–	–	30	ms

## AC General Purpose I/O Specifications

GPIOs are arranged into four ports. Ports 0, 1, and 2 have eight GPIO pins and Port 3 has four GPIO pins. Port 1 has an optional LDO regulator that adjusts the port's output voltage to 1.8, 2.5, or 3.0 V. Additionally, each GPIO pin can be independently set to one of four drive modes: strong drive, open drain, pull-up, or high-Z analog.

Rise and fall times are specified for 10% and 90% voltage values.

Specifications are for the entire operating temperature range.

**Table 9. AC GPIO Specs**

Parameter	Description	Conditions	Min	Typ	Max	Units
F <sub>GPIO</sub>	GPIO operating frequency	Strong drive	0	–	12	MHz
T <sub>RISE_01</sub>	Rise time, ports 0 -1	Strong drive, C <sub>LOAD</sub> = 50 pF, DVDD = 3.0 - 3.6	–	–	50	ns
T <sub>RISE_01_L</sub>	Rise time, ports 0 -1, low supply	Strong drive, C <sub>LOAD</sub> = 50 pF, DVDD = 2.7 - 3.0	–	–	70	ns
T <sub>RISE_LDO_3</sub>	Rise time, port 1, 3 V LDO enabled	Strong drive, C <sub>LOAD</sub> = 50 pF, DVDD > 3.1 V	–	–	50	ns
T <sub>RISE_LDO_2.5</sub>	Rise time, port 1, 2.5 LDO enabled	Strong drive, C <sub>LOAD</sub> = 50 pF, DVDD > 2.7 V	–	–	70	ns
T <sub>RISE_LDO_1.8</sub>	Rise time, port 1, 1.8 LDO enabled	Strong drive, C <sub>LOAD</sub> = 50 pF, DVDD > 2.7 V	–	–	100	ns
T <sub>RISE_23</sub>	Rise time, ports 2 - 3	Strong drive, C <sub>LOAD</sub> = 50 pF, DVDD = 2.7 - 3.6	–	–	80	ns
T <sub>FALL</sub>	Fall time, all ports	Strong drive, C <sub>LOAD</sub> = 50 pF, DVDD = 3.0 - 3.6	–	–	50	ns
T <sub>FALL_L</sub>	Fall time, all ports, low supply	Strong drive, C <sub>LOAD</sub> = 50 pF, DVDD = 2.7 - 3.0	–	–	70	ns
T <sub>FALL_LDO_3</sub>	Fall time, port 1, 3 V LDO enabled	Strong drive, C <sub>LOAD</sub> = 50 pF, DVDD > 3.1 V	–	–	50	ns
T <sub>FALL_LDO_2.5</sub>	Fall time, port 1, 2.5 LDO enabled	Strong drive, C <sub>LOAD</sub> = 50 pF, DVDD > 2.7 V	–	–	70	ns
T <sub>FALL_LDO_1.8</sub>	Fall time, port 1, 1.8 LDO enabled	Strong drive, C <sub>LOAD</sub> = 50 pF, DVDD > 2.7 V	–	–	80	ns

### Notes

8. IMO can be output from chip by routing to GPIO. Maximum GPIO output frequency is 12 MHz, so duty cycle at 24 MHz is not defined. See Technical Reference Manual at [www.cypress.com](http://www.cypress.com) or in Cypress's PSoC Designer software for details on routing IMO to GPIO pin.

9. Available frequency divisors are 1, 2, 4, 8, 16, 32, 128, and 256.

10. 32 kHz oscillator can be locked to external crystal. See technical reference manual available at [www.cypress.com](http://www.cypress.com) or in Cypress' PSoC Designer software.

11. Value provided represents maximum startup time for typical application. Applications requiring additional startup code, processing, or delay may increase TMOT.

### AC External Clock Specifications

The IMO can be replaced with an external clock at the EXT CLK / P[1]4 pin. Refer to the [technical reference manual](#) for more details. [Table 10](#) lists guaranteed maximum and minimum specifications for the entire voltage and temperature ranges.

**Table 10. AC External Clock Specifications**

Parameter	Description	Min	Typ	Max	Unit
F <sub>OSCEXT</sub>	Frequency	0.750	–	25.2	MHz
–	High period	20.6	–	5300	ns
–	Low period	20.6	–	–	ns
–	Required time to run from IMO before switching to external clock	150	–	–	μs

### AC Analog Mux Bus Specifications

The analog mux bus can connect signals from GPIOs to and from internal analog blocks and other GPIOs. [Table 11](#) lists guaranteed maximum and minimum specifications for the entire voltage and temperature ranges.

**Table 11. AC Analog Mux Bus Specifications**

Parameter	Description	Conditions	Min	Typ	Max	Unit
F <sub>SW</sub>	Switch rate	Pin voltage < 1.8 V	–	–	6.3	MHz

### AC Programming Specifications

[Table 12](#) lists guaranteed maximum and minimum specifications for the entire voltage and temperature ranges.

**Table 12. AC Programming Specifications**

Symbol	Description	Conditions	Min	Typ	Max	Units
T <sub>RSCLK</sub>	Rise time of ISSP CLK		1	–	20	ns
T <sub>FSCLK</sub>	Fall time of ISSP CLK		1	–	20	ns
T <sub>SSCLK</sub>	Data setup time to falling edge of ISSP CLK		40	–	–	ns
T <sub>HSCLK</sub>	Data hold time from falling edge of ISSP CLK		40	–	–	ns
F <sub>SCLK</sub>	Frequency of ISSP CLK		0	–	8	MHz
T <sub>ERASEB</sub>	Flash erase time (block)		–	–	18	ms
T <sub>WRITE</sub>	Flash block write time		–	–	25	ms
T <sub>DSCLK2</sub>	Data out delay from falling edge of ISSP CLK	3.0 ≤ DVDD ≤ 3.6	–	–	85	ns

**AC SPI Specifications**

Table 13 lists guaranteed maximum and minimum specifications for the entire voltage and temperature ranges.

**Table 13. AC SPI Master Specifications**

Parameter	Description	Min	Typ	Max	Unit
f <sub>SCLK</sub>	SPI CLK frequency <sup>[12]</sup>	–	–	F <sub>IMO</sub> /2	MHz
t <sub>SETUP</sub>	SPI MISO to SPI CLK setup time	60	–	–	ns
t <sub>HOLD</sub>	SPI CLK to SPI MISO hold time	40	–	–	ns
t <sub>OUT_SU</sub>	SPI MOSI to SPI CLK setup time	40	–	–	ns
t <sub>OUT_H</sub>	SPI CLK to SPI MOSI hold time	40	–	–	ns

**Table 14. AC SPI Slave Specifications**

Parameter	Description	Min	Typ	Max	Unit
f <sub>SCLK</sub>	SPI CLK frequency <sup>[12]</sup>	–	–	12	MHz
t <sub>LOW</sub>	Minimum SPI CLK low width <sup>[13]</sup>	41.67	–	–	ns
t <sub>HIGH</sub>	Minimum SPI CLK high width <sup>[13]</sup>	41.67	–	–	ns
t <sub>SETUP</sub>	SPI MOSI to SPI CLK setup time	25	–	–	ns
t <sub>HOLD</sub>	SPI CLK to SPI MOSI hold time	25	–	–	ns
t <sub>OUT_H</sub>	SPI CLK to SPI MISO hold time	35	–	–	ns
t <sub>SS_MISO</sub>	SPI SS to SPI MISO valid	–	–	100	ns
t <sub>SCLK_MISO</sub>	SPI CLK to SPI MISO valid	–	–	140	ns
t <sub>SS_HIGH</sub>	Minimum SPI SS high width	–	–	35	ns
t <sub>SS_CLK</sub>	Time from SPI SS low to first SPI CLK	–	–	20	ns
t <sub>CLK_SS</sub>	Time from last SPI CLK to SPI SS high	–	–	25	ns

**Notes**

- 12. Clock frequency is half of clock input to SPI block.
- 13. Value corresponds to 50% duty cycle at 12 MHz.

Figure 7. SPI Master Timing Diagram, Modes 0 and 2

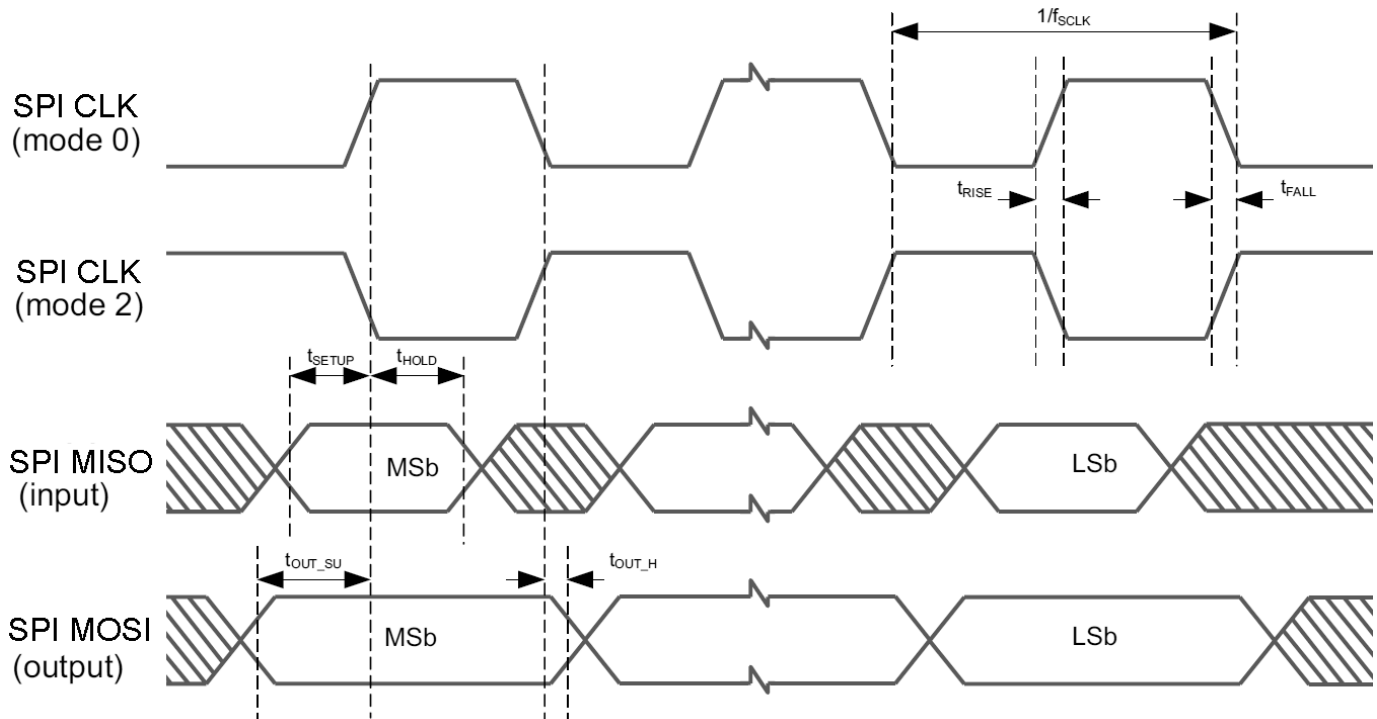

Figure 8. SPI Master Timing Diagram, Modes 1 and 3

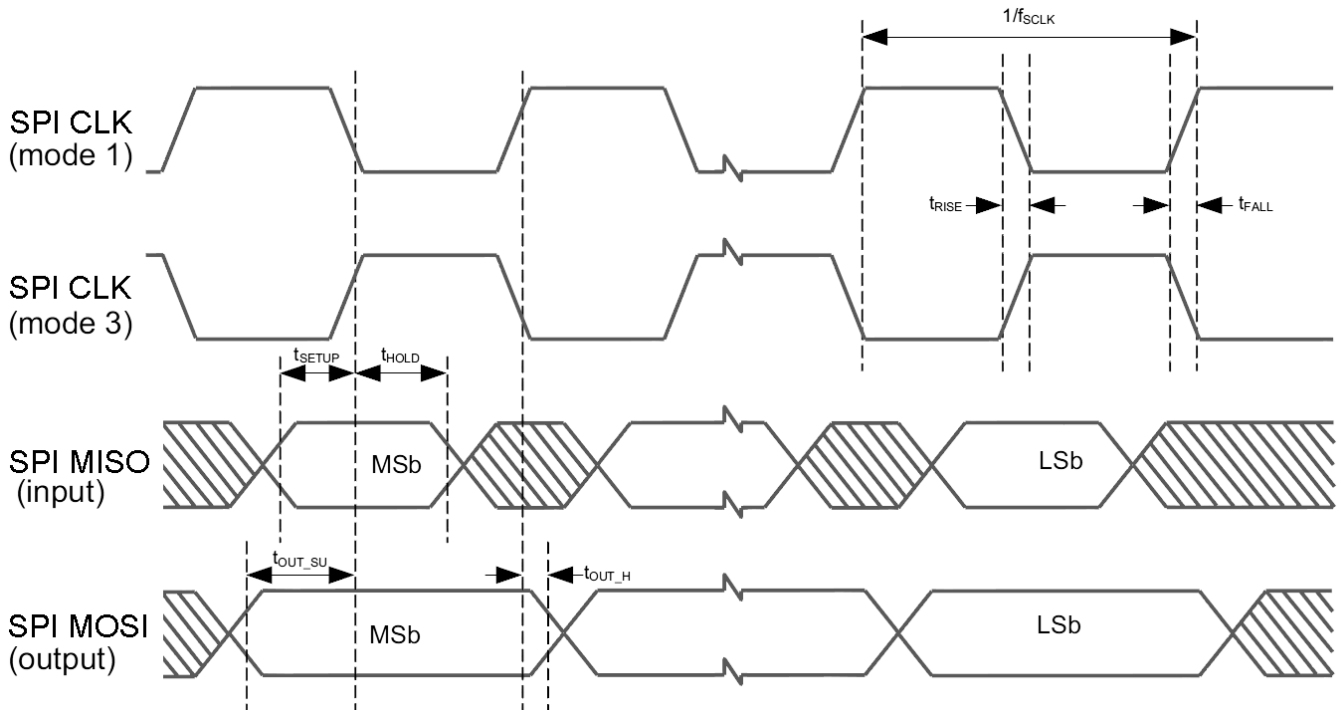

Figure 9. SPI Slave Timing Diagram, Modes 0 and 2

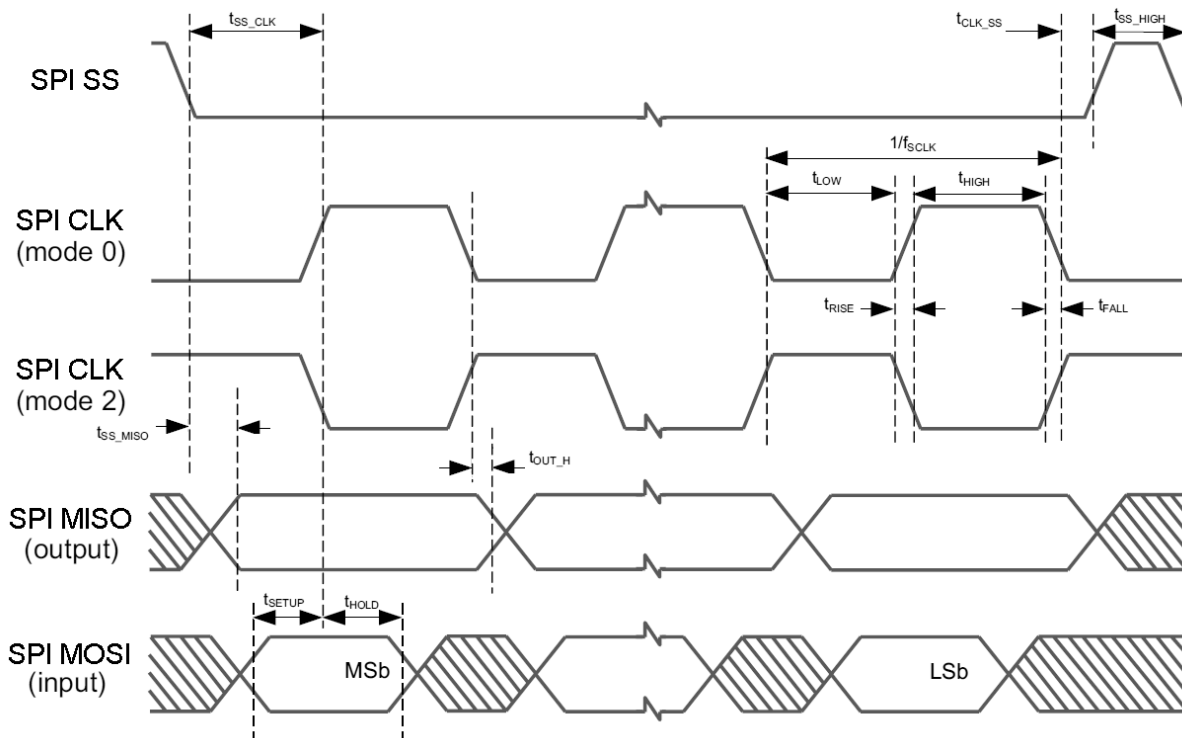
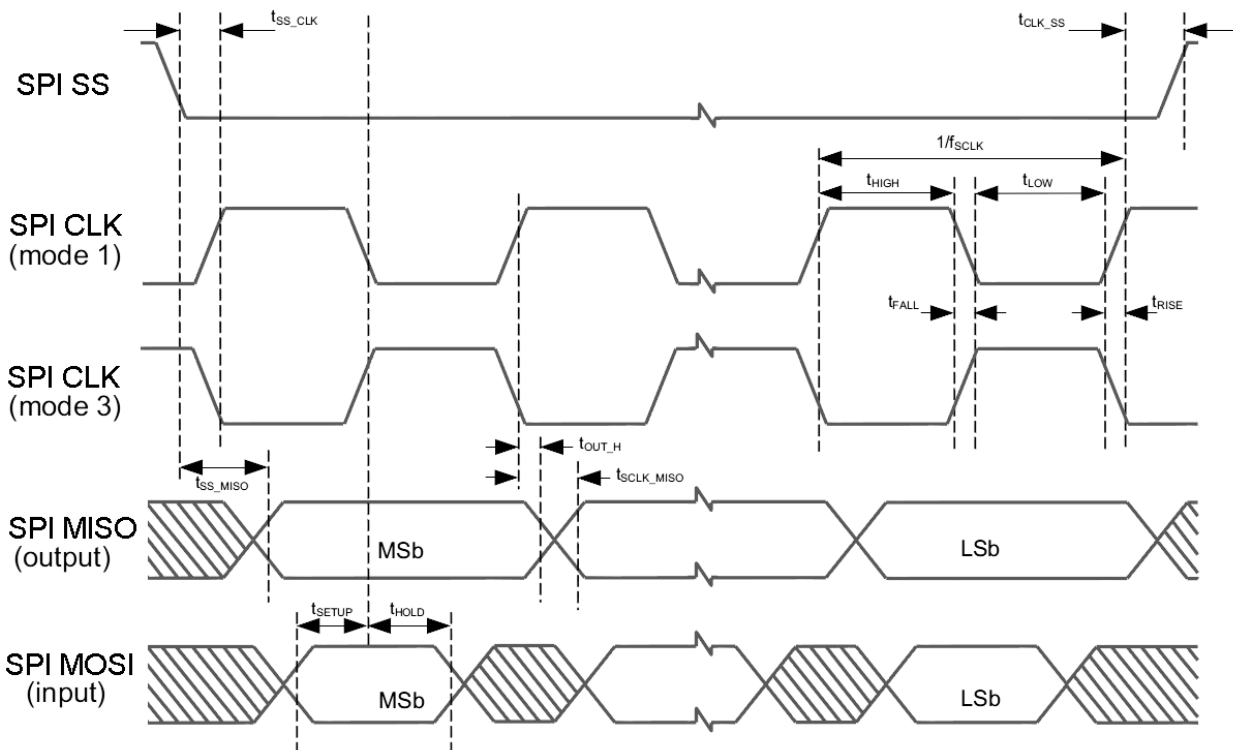

Figure 10. SPI Slave Timing Diagram, Modes 1 and 3



### AC Comparator Specifications

The device includes two general purpose comparators, using internal or external signals from the analog MUX bus. Table 15 lists guaranteed maximum and minimum specifications for the entire voltage and temperature ranges.

**Table 15. AC Low Power Comparator Specifications**

Symbol	Description	Conditions	Min	Typ	Max	Units
T <sub>LPC</sub>	Comparator response time, 50 mV overdrive	50 mV overdrive does not include offset voltage.	–	–	100	ns

### AC I<sup>2</sup>C Specifications

Table 16 lists guaranteed maximum and minimum specifications for the entire voltage and temperature ranges.

**Table 16. AC Characteristics of the I<sup>2</sup>C SDA and SCL Pins**

Symbol	Description	Standard Mode		Fast Mode		Units
		Min	Max	Min	Max	
F <sub>SCL I2C</sub>	I2C_SCL clock frequency	0	100	0	400	kHz
T <sub>HDSTA I2C</sub>	Hold time for START and Repeated START condition	4.0	–	0.6	–	μs
T <sub>LOW I2C</sub>	LOW period of the I2C_SCL clock	4.7	–	1.3	–	μs
T <sub>HIGH I2C</sub>	HIGH period of I2C_SCL clock	4.0	–	0.6	–	μs
T <sub>SUSTA I2C</sub>	Setup time for a START and Repeated START condition	4.7	–	0.6	–	μs
T <sub>HDDA I2C</sub>	Data hold time	0	–	0	–	μs
T <sub>SUDA I2C</sub>	Data setup time	250	–	100 <sup>[14]</sup>	–	ns
T <sub>SUSTO I2C</sub>	Setup time for STOP condition	4.0	–	0.6	–	μs
T <sub>BUFI2C</sub>	Bus free time between a STOP and START condition	4.7	–	1.3	–	μs
T <sub>SPI2C</sub>	Pulse width of spikes that are suppressed by the input filter	–	–	0	50	ns

**Figure 11. Timing for Fast and Standard Mode on the I<sup>2</sup>C Bus**

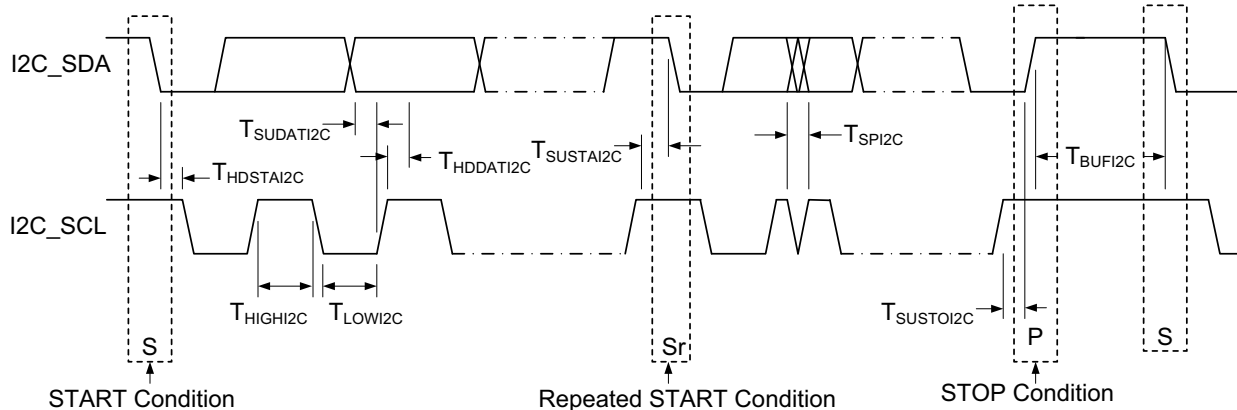

**Note**

14. A Fast-Mode I2C-bus device can be used in a Standard Mode I2C-bus system, but the requirement  $t_{SUDA I2C} \geq 250$  ns must then be met. This automatically is the case if the device does not stretch the LOW period of the SCL signal. If such device does stretch the LOW period of the SCL signal, it must output the next data bit to the SDA line  $t_{max} + t_{SUDA I2C} = 1000 + 250 = 1250$  ns (according to the Standard-Mode I2C-bus specification) before the SCL line is released.



**PCB Land Pads and Keepout Zones**

Figure 12 and Figure 13 show the recommended land pad architecture and keepout zones. The pads on the 42-pin device are a subset of the JEDEC MO-220 52-pin QFN standard. For detailed layout instructions, see application note AN48995, *Mechanical Design Considerations for the OvationONS™ II Laser Navigation System-on-Chip*.

**Figure 12. Land Pad Architecture and Spacing**

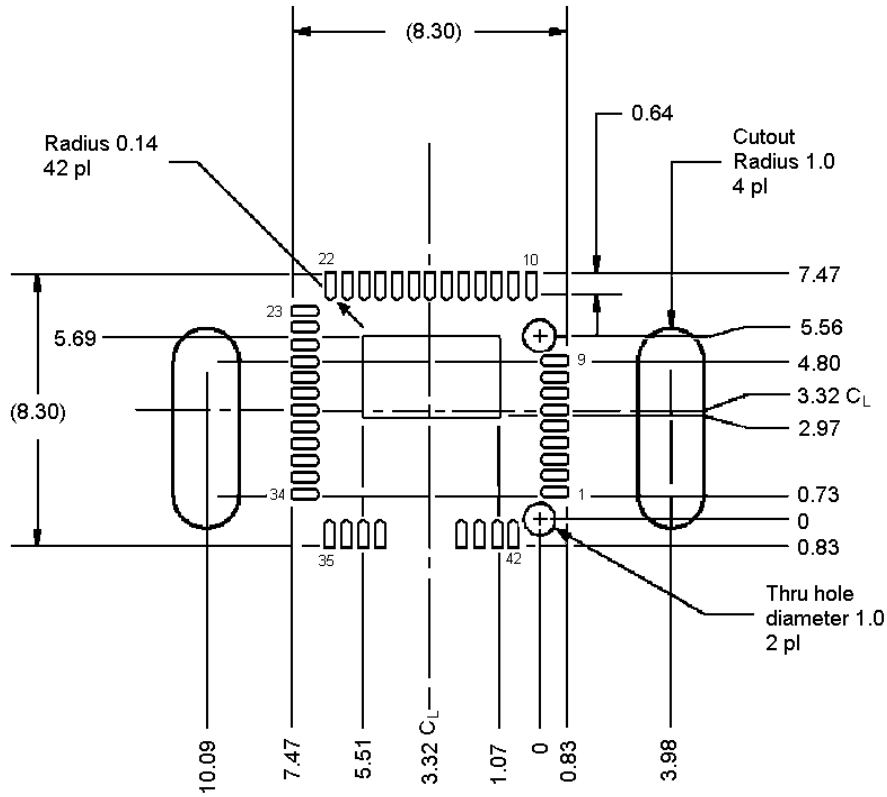

**Figure 13. PCB Keep Out Zones**

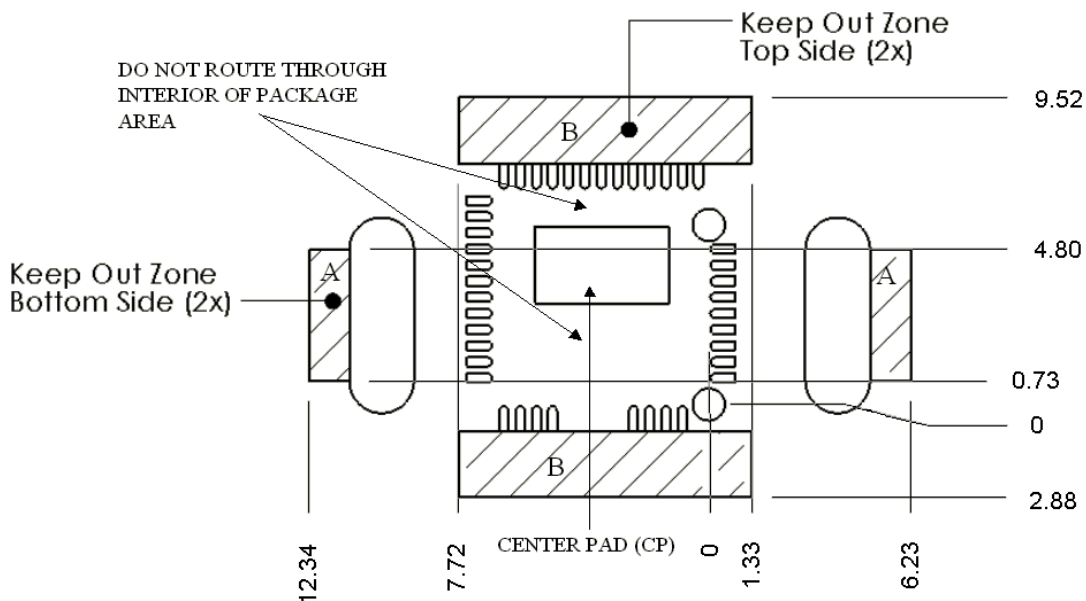

**Orientation of Axes**

Figure 14 describes the relationship between the package and the x/y axes when using the API provided by Cypress's PSoC Designer software. Note that there is a 90-degree rotation between the orientation below and the orientation described in the register section of the [Technical Reference Manual](#). If PSoC Designer is not used, the application firmware should read and invert the Y count register for X data, and read the X count register for Y data.

**Figure 14. Sensor Orientation**

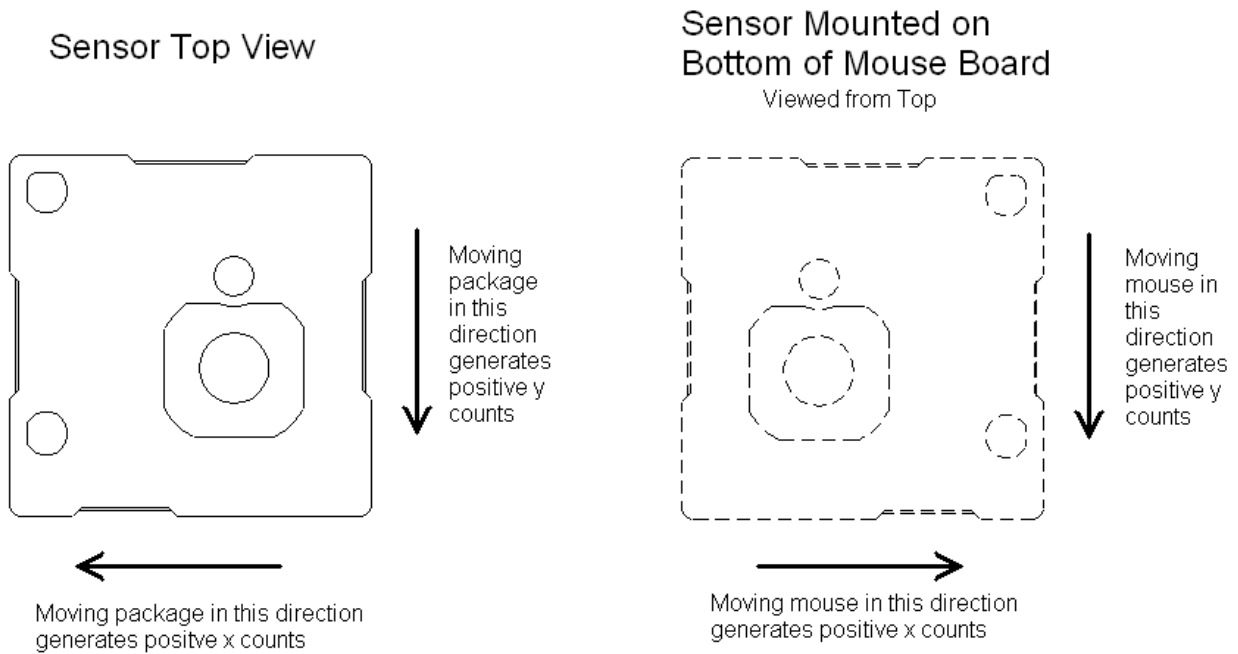

**PCB Mounting Height and Thickness**

Figure 15 shows the recommended thickness and mounting height of the PCB above the tracking surface.

**Figure 15. PCB Height and Thickness**

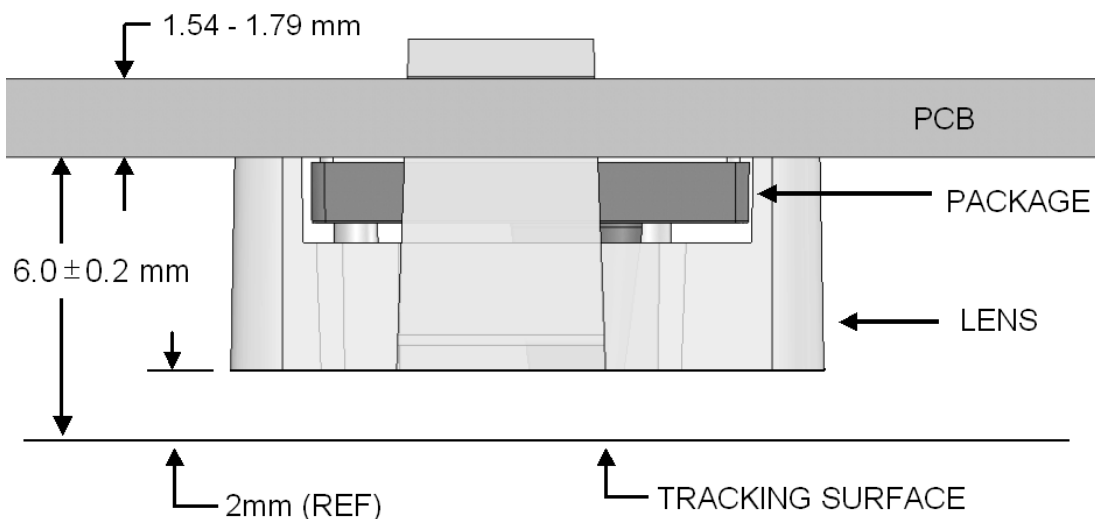

**Thermal Impedances**

**Table 17. Thermal Impedances per Package**

Package	Typical $\theta_{JA}$ <sup>[15]</sup>
42 PQFN <sup>[16]</sup>	24 °C/W

**Solder Reflow Peak Temperature**

Following is the minimum solder reflow peak temperature to achieve good solderability.

**Table 18. Solder Reflow Peak Temperature**

Package	Minimum Peak Temperature <sup>[17]</sup>	Maximum Peak Temperature
42 PQFN	240 °C	260 °C

**Notes**

15.  $T_J = T_A + \text{Power} \times \theta_{JA}$ .

16. To achieve the thermal impedance specified for the QFN package, the center thermal pad must be soldered to the PCB ground plane.

17. Higher temperatures may be required based on the solder melting point. Typical temperatures for solder are  $220 \pm 5^\circ\text{C}$  with Sn-Pb or  $245 \pm 5^\circ\text{C}$  with Sn-Ag-Cu paste. Refer to the solder manufacturer specifications. For a recommended soldering profile, refer to Application Note 49035, *Manufacturing Considerations for the Ovation-ONS™ Laser Navigation System-on-Chip*.

## Laser Safety Considerations

The CYONS2001 Laser Navigation SoC and the CYONSLENS2000 lens are designed and tested to enable manufacturers to achieve eye-safety certification with minimal effort. This section provides guidelines for complying with the Class 1 emission requirements of IEC/EN 60825-1.

When installed and operated in accordance with all requirements in this datasheet, the kit consisting of the CYONS2001 Laser Navigation SoC and CYONSLENS2000 satisfy CDRH 21 CFR 1040 per Laser Notice 50 and IEC/EN 60825-1 Class 1.

### Laser Output Power

The CYONS2001 sensor package contains an integrated VCSEL and drive circuitry. Before shipping, Cypress adjusts the laser output power to eye-safe levels, taking into account specified variations in supply voltage, temperature, lens transmission, and VCSEL polarization, and factors such as VCSEL aging and test equipment accuracy. The output remains within eye-safe limits under reasonably foreseeable single-faults, as required by the IEC standard.

From the perspective of a manufacturer, laser emission remains within the Class 1 limit, as defined in IEC 60825-1, Edition 2, 2007, provided the following requirements are met.

- The supply voltage applied to pins DVDD and AVDD of the SoC must be in the range of 2.7 to 3.6 V.
- The operating temperature must be between 5 and 45 °C.
- The laser output power must not be increased by any means, including but not limited to firmware, hardware, or mechanical modifications to the sensor or lens.
- The mechanical housing must be designed such that the CYONSLENS2000 cannot be removed by the user.
- The device firmware must initialize the VCSEL driver as described in the “VCSEL Driver” chapter of the [OvationONS II Technical Reference Manual](#) or by using the NAV or LaserNAV User Modules in Cypress’ PSoC Designer software.

It is the responsibility of the manufacturer to ensure these conditions are always met and to demonstrate end-product compliance to the appropriate regulatory standards.

### Laser Output Power Test Procedure

To verify the laser output level, follow the steps shown in the “VCSEL Power Calibration and Verification” section of the [technical reference manual](#).

### Registration Assistance

The mouse or end-product supplier is responsible for certifying the end-use product with respect to the drive voltage, manuals and labels, and operating temperature specifications. Additionally, for products sold in the US, a CDRH report must be filed for each model produced, and test and inspection of the product’s characteristics as they relate to laser safety and the CDRH requirements must be performed.

When filing a report with the CDRH, the supplier can refer to the product report filed by Cypress for the CYONS2xxx family of products. The Cypress report is based on the previously-noted limits for voltage and temperature, and describes how the sensor design includes consideration of drive circuit failures, laser output variation with temperature, drive circuit variation with temperature and voltage, polarization sensitivity of molded optics, and measurement uncertainties.

Cypress can provide assistance to customers who want to obtain registration. Supporting documentation, including a verification test procedure to demonstrate end-product compliance with IEC and CDRH requirements is available.

## Development Tool Selection

This section presents the development tools available for all current PSoC device families including the CYONS2001.

### Software

#### *PSoC Designer*

At the core of the PSoC development software suite is PSoC Designer, used to generate PSoC firmware applications. PSoC Designer is available free of charge at <http://www.cypress.com/psocdesigner> and includes a free C compiler with version Service Pack 4.5 or later.

#### *PSoC Programmer*

Flexible enough to be used on the bench in development, yet suitable for factory programming, PSoC Programmer works either as a standalone programming application or it can operate directly from PSoC Designer. PSoC Programmer software is compatible with both PSoC ICE-Cube In-Circuit Emulator and PSoC MiniProg. PSoC programmer is available free of charge at <http://www.cypress.com/psocprogrammer>.

### Mouse Design Kits

Two kits featuring the OvationONS II family of products are available. The reference design kit provides a complete hardware, firmware, and software solution, ready for production. The demonstration kit provides tested hardware and firmware that demonstrate the capabilities of the OvationONS II device.

- CY4631 Wired Mouse Reference Design Kit
- Wireless Mouse Demonstration Kit

### Development Kits

You can purchase the development kits from the Cypress Online Store.

#### *CY3215-DK Basic Development Kit*

The [CY3215-DK](#) kit enables prototyping and development with PSoC Designer. This kit supports in-circuit emulation and the software interface enables users to run, halt, and single step the processor and view the content of specific memory locations. Advance emulation features also supported through PSoC Designer. The kit includes:

- PSoC Designer software CD
- ICE-Cube In-Circuit Emulator
- ICE Flex-Pod for CY8C29x66 family
- Cat-5 adapter
- Mini-Eval programming board
- 110 ~ 240 V power supply, Euro-Plug adapter

- iMAGEcraft C compiler (registration required)
- ISSP cable
- USB 2.0 cable and Blue Cat-5 cable
- Two CY8C29466-24PXI 28-PDIP chip samples

### Evaluation Tools

You can purchase the evaluation tools from the Cypress Online Store.

#### *CY3210-MiniProg1*

The [CY3210-MiniProg1 kit](#) enables a user to program PSoC devices using the MiniProg1 programming unit. The MiniProg is a small, compact prototyping programmer that connects to the PC via a provided USB 2.0 cable. The kit includes:

- MiniProg programming unit
- MiniEval socket programming and evaluation board
- 28-pin CY8C29466-24PXI PDIP PSoC device sample
- 28-pin CY8C27443-24PXI PDIP PSoC device sample
- PSoC Designer software CD
- Getting Started guide
- USB 2.0 cable

#### *CY3210-PSoCEval1*

The [CY3210-PSoCEval1 kit](#) features an evaluation board and the MiniProg1 programming unit. The evaluation board includes an LCD module, potentiometer, LEDs, and plenty of bread-boarding space to meet all your evaluation needs. The kit includes:

- Evaluation board with LCD module
- MiniProg programming unit
- 28-pin CY8C29466-24PXI PDIP PSoC Device Sample (2)
- PSoC Designer software CD
- Getting Started guide
- USB 2.0 cable

#### *CY3214-PSoCEvalUSB*

The [CY3214-PSoCEvalUSB evaluation kit](#) features a development board for the CY8C24794-24LFXI PSoC device. Special features of the board include both USB and capacitive sensing development and debugging support.

This evaluation board also includes an LCD module, potentiometer, LEDs, an enunciator and plenty of bread boarding space to meet all your evaluation needs. The kit includes:

- PSoCEvalUSB board
- LCD module
- MiniProg programming unit
- Mini USB cable
- PSoC Designer and example projects CD
- Getting Started guide
- Wire pack

## Device Programmers

You can purchase the device programmers from the Cypress Online Store.

### *CY3216 Modular Programmer*

The [CY3216 Modular Programmer kit](#) features a modular programmer and the MiniProg1 programming unit. The modular programmer includes three programming module cards and supports multiple Cypress products. The kit includes:

- Modular programmer base
- Three programming module cards
- MiniProg programming unit
- PSoC Designer software CD
- Getting Started guide
- USB 2.0 cable

### *CY3207ISSP In-System Serial Programmer (ISSP)*

The [CY3207ISSP](#) is a production programmer. It includes protection circuitry and an industrial case that is more robust than the MiniProg in a production-programming environment.

**Note** CY3207ISSP needs special software and is not compatible with PSoC Programmer.

The kit includes:

- CY3207 programmer unit
- PSoC ISSP software CD
- 110 ~ 240 V power supply, Euro-Plug adapter
- USB 2.0 cable

## Third Party Tools

Several tools have been specially designed by third-party vendors to accompany PSoC devices during development and production. Specific details for each of these tools are found at <http://www.cypress.com>.

Package Diagrams

Figure 16. QFN Package

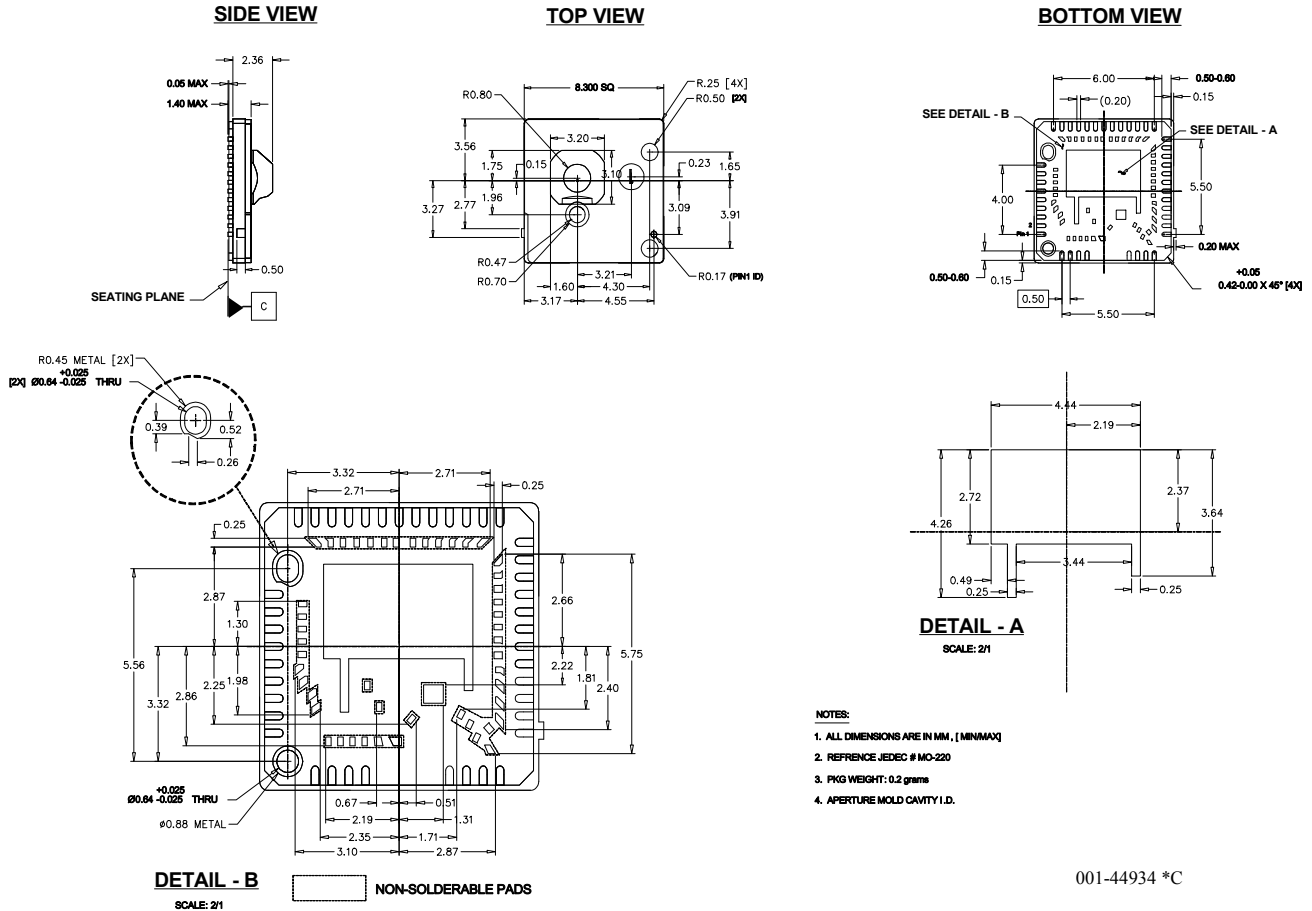

**Figure 17. Lens**

GATE FLASH: 0.30MM MAX

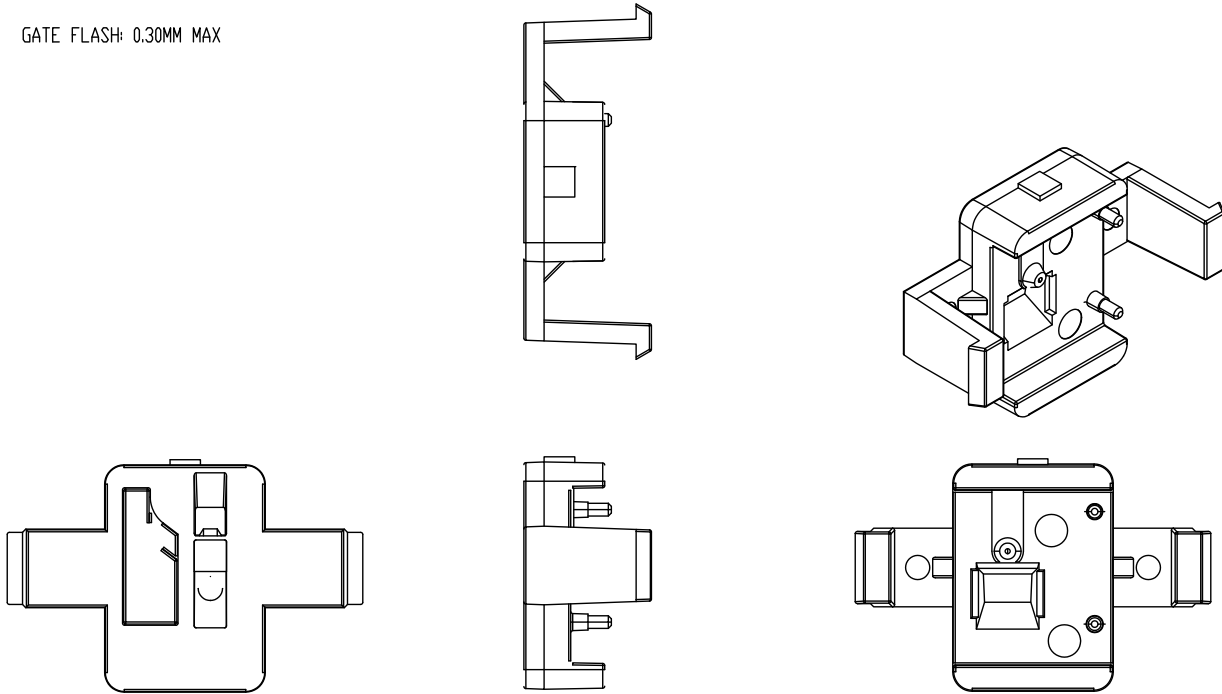

001-44677 \*B

**Ordering Information**

The CYONS2001 and CYONSLENS2000 are sold separately. When placing orders, order both part numbers

Part Number	Package	Application
CYONS2001-LBXC	42-pin PQFN	Desktop wireless
CYONSLENS2000-C	Lens - 4 mm height	Molded optic

**Ordering Code Definition**



CYONS XXXX-XXX C

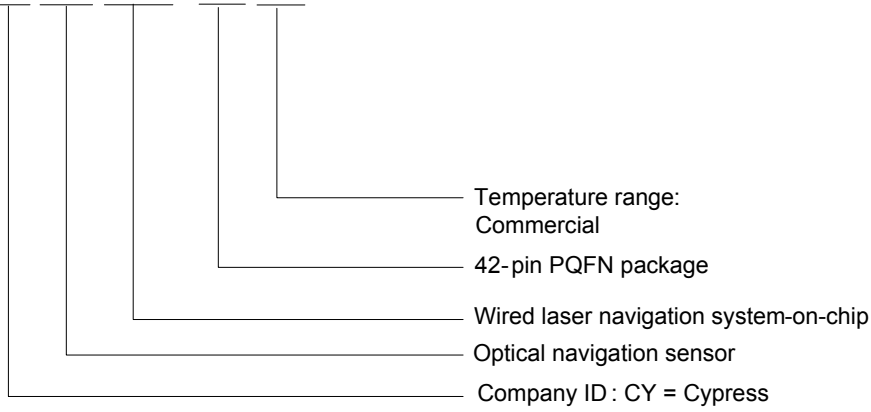

## Document Conventions

### Acronyms Used

Table 19 lists the acronyms used in this document.

### Units of Measure

The units of measure in Table 20 lists the abbreviations used to measure the devices.

### Numeric Naming

Hexadecimal numbers are represented with all letters in uppercase with an appended lowercase 'h' (for example, '14h' or '3Ah'). Hexadecimal numbers may also be represented by a '0x' prefix, the C coding convention. Binary numbers have an appended lowercase 'b' (for example, '01010100b' or '01000011b'). Numbers not indicated by an 'h', 'b', or '0x' are decimal.

Table 19. Acronyms

Acronym	Description	Acronym	Description
AC	Alternating Current	LDO	Low Drop Out (regulator)
ADC	Analog to Digital Converter	LED	Light Emitting Diode
API	Application Programming Interface	LPC	Low Power Comparator
CDRH	Center for Devices and Radiological Health	LSb	Least-significant Bit
CPI	Counts per Inch	LVD	Low Voltage Detect
CPU	Central Processing Unit	M8C	Cypress' 8-bit CPU Core
DAC	Digital to Analog Converter	MCU	Microcontroller Unit
DC	Direct Current	MIPS	Million Instructions per Second
DSP	Digital Signal Processor	MSb	Most-significant Bit
ESD	Electrostatic Discharge	MUX	Multiplexer
GND	Ground	PC, PCB	Printed Circuit, Printed Circuit Board
GPIO	General Purpose I/O	PDIP	Plastic Dual In-Line Package
HEX	Hexadecimal	PGA	Programmable Gain Amplifier
High-Z	High Impedance	POR	Power On Reset
I <sup>2</sup> C	Inter-Integrated Circuit (bus)	PQFN	Plastic Quad Flat No-Leads (package)
ICE	In-circuit Emulator	PSoC	Programmable System-on-Chip
IDAC	DAC-Controlled Current Source	PSRR	Power Supply Rejection Ratio
IDE	Integrated Development Environment	PWM	Pulse Width Modulator
IEC	International Electrotechnical Commission	QFN	Quad Flat No-Leads (package)
ILO	Internal Low Speed Oscillator	SoC	System on Chip
IMO	Internal Main Oscillator	SPI	Serial Peripheral Interface (bus)
I/O	Input/Output	SRAM	Static Random Access Memory
JEDEC	Joint Electron Devices Engineering Council	USB	Universal Serial Bus
LCD	Liquid Crystal Display	VCSEL	Vertical Cavity Surface Emitting Laser

Table 20. Units of Measure

Symbol	Unit of Measure	Symbol	Unit of Measure
°C	degree Celsius	μV	microvolts
g	acceleration of gravity	mA	milliampere
KB	1024 bytes	ms	millisecond
in/s	inches per second	mV	millivolt
kHz	kilohertz	nH	nanohenry
kΩ	kilohm	nm	nanometer
kV	kilovolt	ns	nanosecond
MHz	megahertz	Ω	ohm
μA	microampere	pF	picofarad
μF	microfarad	pp	peak-to-peak
μH	microhenry	V	volt
μs	microsecond	W	watt

## Document History Page

Document Title: CYONS2001 OvationONS™ II Wireless Laser Navigation System-on-Chip				
Document Number: 001-44045				
Revision	ECN	Orig. of Change	Submission Date	Description of Change
**	2261927	FJZ	See ECN	New Data Sheet.
*A	2580125	FJZ/PYRS	10/07/08	Extensive Updates
*B	2769396	FJZ/AESA	25/09/09	Updated Getting Started and Development Tools sections Updated thermal impedance, wireless kit info, Flash specs, storage temperature, I2C footnote, external mode powering, reference schematic, power specifications, pin table, and c compiler information.
*C	2889331	FJZ	03/09/10	Added Table of Contents. Updated package diagram and sales links.
*D	2903558	FJZ	04/20/10	Update LVD, USB, SPI Master and SPI Slave specs, numerous minor updates for improved clarity and consistency
*E	2936335	MMCY	05/24/2010	Updated content to match the new template and style guide. No technical updates.
*F	3092209	FJZ	11/22/2010	Corrected error in <a href="#">Pin Description</a> . Removed invalid reference to application note in <a href="#">Registration Assistance</a> .
*G	3126503	FJZ	01/03/2011	Updated <a href="#">Figure 17</a> . Changed posting to external web

## Sales, Solutions, and Legal Information

### Worldwide Sales and Design Support

Cypress maintains a worldwide network of offices, solution centers, manufacturer’s representatives, and distributors. To find the office closest to you, visit us at [Cypress Locations](#).

### Products

- [Automotive](#) [cypress.com/go/automotive](http://cypress.com/go/automotive)
- [Clocks & Buffers](#) [cypress.com/go/clocks](http://cypress.com/go/clocks)
- [Interface](#) [cypress.com/go/interface](http://cypress.com/go/interface)
- [Lighting & Power Control](#) [cypress.com/go/powerpsoc](http://cypress.com/go/powerpsoc)  
[cypress.com/go/plc](http://cypress.com/go/plc)
- [Memory](#) [cypress.com/go/memory](http://cypress.com/go/memory)
- [Optical & Image Sensing](#) [cypress.com/go/image](http://cypress.com/go/image)
- [PSoC](#) [cypress.com/go/psoc](http://cypress.com/go/psoc)
- [Touch Sensing](#) [cypress.com/go/touch](http://cypress.com/go/touch)
- [USB Controllers](#) [cypress.com/go/USB](http://cypress.com/go/USB)
- [Wireless/RF](#) [cypress.com/go/wireless](http://cypress.com/go/wireless)

### PSoC Solutions

- [psoc.cypress.com/solutions](http://psoc.cypress.com/solutions)
- [PSoC 1](#) | [PSoC 3](#) | [PSoC 5](#)

© Cypress Semiconductor Corporation, 2008-2011. The information contained herein is subject to change without notice. Cypress Semiconductor Corporation assumes no responsibility for the use of any circuitry other than circuitry embodied in a Cypress product. Nor does it convey or imply any license under patent or other rights. Cypress products are not warranted nor intended to be used for medical, life support, life saving, critical control or safety applications, unless pursuant to an express written agreement with Cypress. Furthermore, Cypress does not authorize its products for use as critical components in life-support systems where a malfunction or failure may reasonably be expected to result in significant injury to the user. The inclusion of Cypress products in life-support systems application implies that the manufacturer assumes all risk of such use and in doing so indemnifies Cypress against all charges.

Any Source Code (software and/or firmware) is owned by Cypress Semiconductor Corporation (Cypress) and is protected by and subject to worldwide patent protection (United States and foreign), United States copyright laws and international treaty provisions. Cypress hereby grants to licensee a personal, non-exclusive, non-transferable license to copy, use, modify, create derivative works of, and compile the Cypress Source Code and derivative works for the sole purpose of creating custom software and or firmware in support of licensee product to be used only in conjunction with a Cypress integrated circuit as specified in the applicable agreement. Any reproduction, modification, translation, compilation, or representation of this Source Code except as specified above is prohibited without the express written permission of Cypress.

Disclaimer: CYPRESS MAKES NO WARRANTY OF ANY KIND, EXPRESS OR IMPLIED, WITH REGARD TO THIS MATERIAL, INCLUDING, BUT NOT LIMITED TO, THE IMPLIED WARRANTIES OF MERCHANTABILITY AND FITNESS FOR A PARTICULAR PURPOSE. Cypress reserves the right to make changes without further notice to the materials described herein. Cypress does not assume any liability arising out of the application or use of any product or circuit described herein. Cypress does not authorize its products for use as critical components in life-support systems where a malfunction or failure may reasonably be expected to result in significant injury to the user. The inclusion of Cypress’ product in a life-support systems application implies that the manufacturer assumes all risk of such use and in doing so indemnifies Cypress against all charges.

Use may be limited by and subject to the applicable Cypress software license agreement.