



Voltage Supervisor with 2-Kb and 4-Kb SPI Serial CMOS EEPROM



FEATURES

- Precision Power Supply Voltage Monitor
 - 5V, 3.3V, 3V & 2.5V systems
 - 7 threshold voltage options
- Active High or Low Reset
 - Valid reset guaranteed at $V_{CC} = 1V$
- 10MHz SPI compatible
- 16-byte page write buffer
- Low power CMOS technology
- 1,000,000 Program/Erase cycles
- 100 year data retention
- Industrial temperature range
- RoHS-compliant 8-pin SOIC package

For Ordering Information details, see page 14.

PIN CONFIGURATION

SOIC (W)			
\bar{CS}	1	8	V_{CC}
SO	2	7	RST/ \bar{RST}
\bar{WP}	3	6	SCK
V_{SS}	4	5	SI

PIN FUNCTION

Pin Name	Function
\bar{CS}	Chip Select
SO	Serial Data Output
\bar{WP}	Write Protect
V_{SS}	Ground
SI	Serial Data Input
SCK	Serial Clock Input
RST/ \bar{RST}	Reset Output
V_{CC}	Power Supply

DESCRIPTION

The CAT15002/04 (see table below) are memory and supervisory solutions for microcontroller based systems. A CMOS serial EEPROM memory and a system power supervisor with brown-out protection are integrated together. Memory interface is via SPI bus serial interface.

The CAT15002/04 provides a precision V_{CC} sense circuit with two reset output options: CMOS active low output or CMOS active high. The RESET output is active whenever V_{CC} is below the reset threshold or falls below the reset threshold voltage.

The power supply monitor and reset circuit protect system controllers during power up/down and against brownout conditions. Seven reset threshold voltages support 5V, 3.3V, 3V and 2.5V systems. If power supply voltages are out of tolerance reset signals become active, preventing the system microcontroller, ASIC or peripherals from operating. Reset signals become inactive typically 240ms after the supply voltage exceeds the reset threshold level.

MEMORY SIZE SELECTOR

Product	Memory density
15002	2-Kbit
15004	4-Kbit

THRESHOLD SUFFIX SELECTOR

Nominal Threshold Voltage	Threshold Suffix Designation
4.63V	L
4.38V	M
4.00V	J
3.08V	T
2.93V	S
2.63V	R
2.32V	Z

BLOCK DIAGRAM

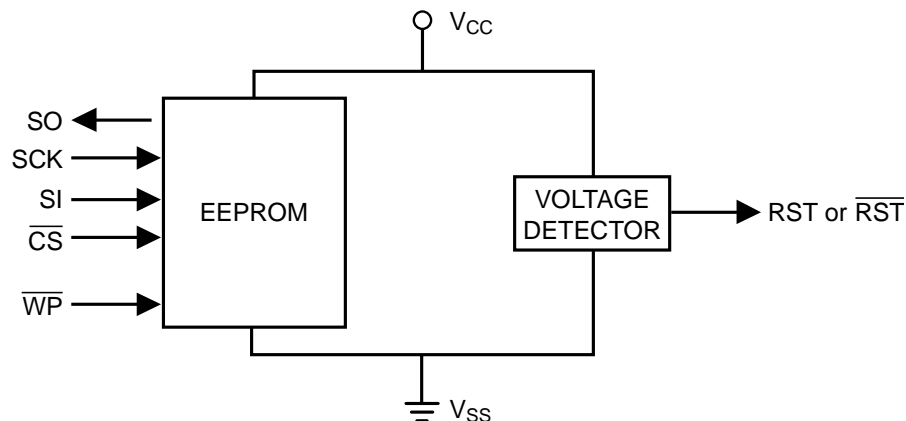

ABSOLUTE MAXIMUM RATINGS⁽¹⁾

Parameters	Ratings	Units
Storage Temperature	-65 to +150	°C
Voltage on Any Pin with Respect to Ground ⁽²⁾	-0.5 to +6.5	V

RELIABILITY CHARACTERISTICS⁽³⁾

Symbol	Parameter	Min	Units
NEND ⁽⁴⁾	Endurance	1,000,000	Program/ Erase Cycles
TDR	Data Retention	100	Years

D.C. OPERATING CHARACTERISTICS

V_{CC} = +2.5V to +5.5V unless otherwise specified.

Symbol	Parameter	Limits			Test Condition	Units
		Min.	Typ.	Max.		
I _{CC}	Supply Current			2	Read or Write at 10MHz, SO open	mA
I _{SB}	Standby Current		12	25	V _{CC} < 5.5V; V _{IN} = V _{SS} or V _{CC} , CS = V _{CC}	µA
			10	20	V _{CC} < 3.6V; V _{IN} = V _{SS} or V _{CC} , CS = V _{CC}	
I _L	I/O Pin Leakage			2	Pin at GND or V _{CC}	µA
V _{IL}	Input Low Voltage	-0.5		0.3 V _{CC}		V
V _{IH}	Input High Voltage	0.7 V _{CC}		V _{CC} + 0.5		V
V _{OL}	Output Low Voltage			0.4	V _{CC} ≥ 2.5V, I _{OL} = 3.0mA	V
V _{OH}	Output High Voltage	V _{CC} - 0.8			V _{CC} ≥ 2.5V, I _{OH} = -1.6mA	V

Notes:

- (1) Stresses above those listed under "Absolute Maximum Ratings" may cause permanent damage to the device. These are stress ratings only, and functional operation of the device at these or any other conditions outside of those listed in the operational sections of this specification is not implied. Exposure to any absolute maximum rating for extended periods may affect device performance and reliability.
- (2) The DC input voltage on any pin should not be lower than -0.5V or higher than V_{CC} + 0.5V. During transitions, the voltage on any pin may undershoot to no less than -1.5V or overshoot to no more than V_{CC} + 1.5V, for periods of less than 20ns.
- (3) These parameters are tested initially and after a design or process change that affects the parameter according to appropriate AEC-Q100 and JEDEC test methods.
- (4) Page Mode, V_{CC} = 5V, 25°C

A.C. CHARACTERISTICS (MEMORY)⁽¹⁾

$V_{CC} = 2.5V$ to $5.5V$, $T_A = -40^{\circ}C$ to $85^{\circ}C$, unless otherwise specified.

Symbol	Parameter	Min.	Max.	Units
f_{SCK}	Clock Frequency	DC	10	MHz
t_{SU}	Data Setup Time	20		ns
t_H	Data Hold Time	20		ns
t_{WH}	SCK High Time	40		ns
t_{WL}	SCK Low Time	40		ns
t_{LZ}	HOLD to Output Low Z		25	ns
$t_{RI}^{(2)}$	Input Rise Time		2	μs
$t_{FI}^{(2)}$	Input Fall Time		2	μs
t_{HD}	HOLD Setup Time	0		ns
t_{CD}	HOLD Hold Time	10		ns
t_V	Output Valid from Clock Low		40	ns
t_{HO}	Output Hold Time	0		ns
t_{DIS}	Output Disable Time		20	ns
t_{HZ}	HOLD to Output High Z		25	ns
t_{CS}	CS High Time	15		ns
t_{CSS}	CS Setup Time	15		ns
t_{CSH}	CS Hold Time	15		ns
t_{WPS}	WP Setup Time	10		ns
t_{WPH}	WP Hold Time	10		ns
$t_{WC}^{(4)}$	Write Cycle Time		5	ms
$t_{PU}^{(2)(3)}$	Power-up to Ready Mode		1	ms

Notes:

- (1) Test conditions according to "A.C. Test Conditions" table.
- (2) Tested initially and after a design or process change that affects this parameter.
- (3) t_{PU} is the delay between the time V_{CC} is stable and the device is ready to accept commands.
- (4) t_{WC} is the time from the rising edge of \overline{CS} after a valid write sequence to the end of the internal write cycle.

A.C. TEST CONDITIONS

Input Rise and Fall Times	$\leq 10ns$
Input Levels	$0.3 V_{CC}$ to $0.7 V_{CC}$
Timing Reference Levels	$0.5 V_{CC}$
Output Load	Current Source: I_{OL} max/ I_{OH} max; $C_L = 50pF$

ELECTRICAL CHARACTERISTICS (SUPERVISORY FUNCTION)

V_{CC} = Full range, T_A = -40°C to +85°C unless otherwise noted. Typical values at T_A = +25°C and V_{CC} = 5V for L/M/J versions, V_{CC} = 3.3V for T/S versions, V_{CC} = 3V for R version and V_{CC} = 2.5V for Z version.

Symbol	Parameter	Threshold	Conditions	Min	Typ	Max	Units
V _{TH}	Reset Threshold Voltage	L	T _A = +25°C	4.56	4.63	4.70	V
			T _A = -40°C to +85°C	4.50		4.75	
		M	T _A = +25°C	4.31	4.38	4.45	
			T _A = -40°C to +85°C	4.25		4.50	
		J	T _A = +25°C	3.93	4.00	4.06	
			T _A = -40°C to +85°C	3.89		4.10	
		T	T _A = +25°C	3.04	3.08	3.11	
			T _A = -40°C to +85°C	3.00		3.15	
		S	T _A = +25°C	2.89	2.93	2.96	
			T _A = -40°C to +85°C	2.85		3.00	
		R	T _A = +25°C	2.59	2.63	2.66	
			T _A = -40°C to +85°C	2.55		2.70	
		Z	T _A = +25°C	2.28	2.32	2.35	
			T _A = -40°C to +85°C	2.25		2.38	

Symbol	Parameter	Conditions	Min	Typ ⁽¹⁾	Max	Units
	Reset Threshold Tempco			30		ppm/°C
t _{RPD}	V _{CC} to Reset Delay ⁽²⁾	V _{CC} = V _{TH} to (V _{TH} -100mV)		20		µs
t _{PURST}	Reset Active Timeout Period	T _A = -40°C to +85°C	140	240	460	ms
V _{OL}	RESET Output Voltage Low (Push-pull, active LOW, CAT150xx9)	V _{CC} = V _{TH} min, I _{SINK} = 1.2mA R/S/T/Z			0.3	V
		V _{CC} = V _{TH} min, I _{SINK} = 3.2mA J/L/M			0.4	
		V _{CC} > 1.0V, I _{SINK} = 50µA			0.3	
V _{OH}	RESET Output Voltage High (Push-pull, active LOW, CAT150xx9)	V _{CC} = V _{TH} max, I _{SOURCE} = -500µA R/S/T/Z	0.8V _{CC}			V
		V _{CC} = V _{TH} max, I _{SOURCE} = -800µA J/L/M	V _{CC} - 1.5			
V _{OL}	RESET Output Voltage Low (Push-pull, active HIGH, CAT150xx1)	V _{CC} > V _{TH} max, I _{SINK} = 1.2mA R/S/T/Z			0.3	V
		V _{CC} > V _{TH} max, I _{SINK} = 3.2mA J/L/M			0.4	
V _{OH}	RESET Output Voltage High (Push-pull, active HIGH, CAT150xx1)	1.8V < V _{CC} ≤ V _{TH} min, I _{SOURCE} = -150µA	0.8V _{CC}			V

Notes:

- (1) Production testing done at T_A = +25°C; limits over temperature guaranteed by design only.
- (2) RESET output for the CAT150xx9; RESET output for the CAT150xx1.

PIN DESCRIPTION

RESET/RESET: Reset output is available in two versions: CMOS Active Low (CAT150xx9) and CMOS Active High (CAT150xx1). Both versions are push-pull outputs for high efficiency.

SI: The serial data input pin accepts op-codes, addresses and data. In SPI modes (0,0) and (1,1) input data is latched on the rising edge of the SCK clock input.

SO: The serial data output pin is used to transfer data out of the device. In SPI modes (0,0) and (1,1) data is shifted out on the falling edge of the SCK clock.

SCK: The serial clock input pin accepts the clock provided by the host and used for synchronizing communication between host and CAT15002/04.

CS: The chip select input pin is used to enable/disable the CAT15002/04. When CS is high, the SO output is tri-stated (high impedance) and the device is in Standby Mode (unless an internal write operation is in progress). Every communication session between host and CAT15002/04 must be preceded by a high to low transition and concluded with a low to high transition of the CS input.

WP: The write protect input pin will allow all write operations to the device when held high. When WP pin is tied low all write operations are inhibited.

DEVICE OPERATION

The CAT15002/04 products combine the accurate voltage monitoring capabilities of a standalone voltage supervisor with the high quality and reliability of standard EEPROMs from Catalyst Semiconductor.

RESET CONTROLLER DESCRIPTION

The reset signal is asserted LOW for the CAT150xx9 and HIGH for the CAT150xx1 when the power supply voltage falls below the threshold trip voltage and remains asserted for at least 140ms (t_{PURST}) after the power supply voltage has risen above the threshold. Reset output timing is shown in Figure 1.

The CAT15002/04 devices protect μ Ps against brown-out failure. Short duration V_{CC} transients of 4 μ sec or less and 100mV amplitude typically do not generate a Reset pulse.

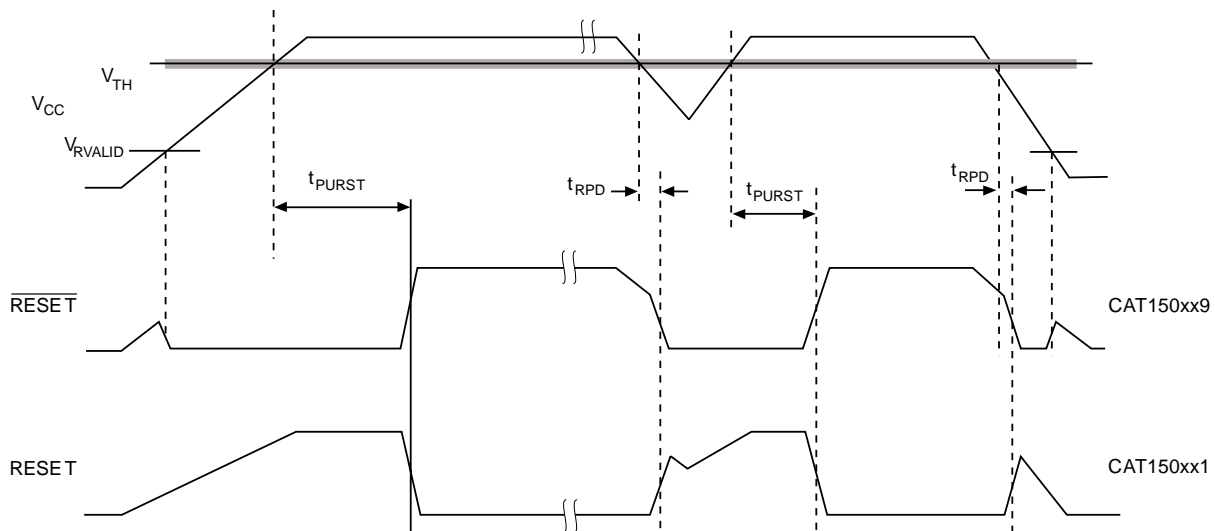

Figure 1. RESET Output Timing

Figure 2 shows the maximum pulse duration of negative-going V_{CC} transients that do not cause a reset condition. As the amplitude of the transient goes further below the threshold (increasing $V_{TH} - V_{CC}$), the maximum pulse duration decreases. In this test, the V_{CC} starts from an initial voltage of 0.5V above the threshold and drops below it by the amplitude of the overdrive voltage ($V_{TH} - V_{CC}$).

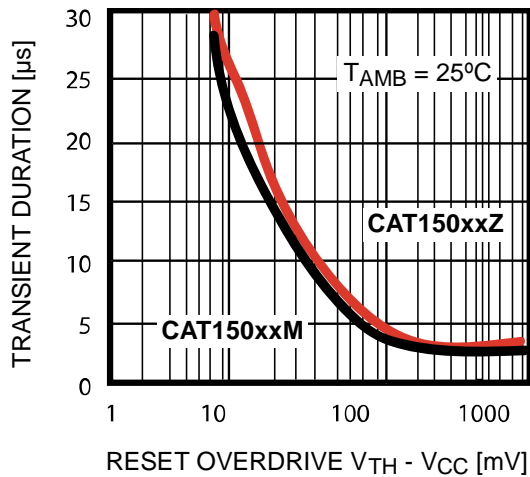

Figure 2. Maximum Transient Duration without Causing a Reset Pulse vs. Overdrive Voltage

EMBEDDED EEPROM DESCRIPTION

The CAT15002/04 devices support the Serial Peripheral Interface (SPI) bus protocol, modes (0,0) and (1,1). The device contains an 8-bit instruction register. The instruction set and associated op-codes are listed in Table 1.

Reading data stored in the CAT15002/04 is accomplished by simply providing the READ command and an address. Writing to the CAT15002/04, in addition to a WRITE command, address and data, also requires enabling the device for writing by first setting certain bits in a Status Register, as will be explained later.

After a high to low transition on the CS input pin, the CAT15002/04 will accept any one of the six instruction op-codes listed in Table 1 and will ignore all other possible 8-bit combinations. The communication protocol follows the timing from Figure 3.

Table 1: Instruction Set

Instruction	Opcode	Operation
WREN	0000 0110	Enable Write Operations
WRDI	0000 0100	Disable Write Operations
RDSR	0000 0101	Read Status Register
WRSR	0000 0001	Write Status Register
READ	0000 x011	Read Data from Memory
WRITE	0000 x010	Write Data to Memory

Note:
 x = 0 for CAT15002,
 x = A8 for CAT15004

Figure 3. Synchronous Data Timing

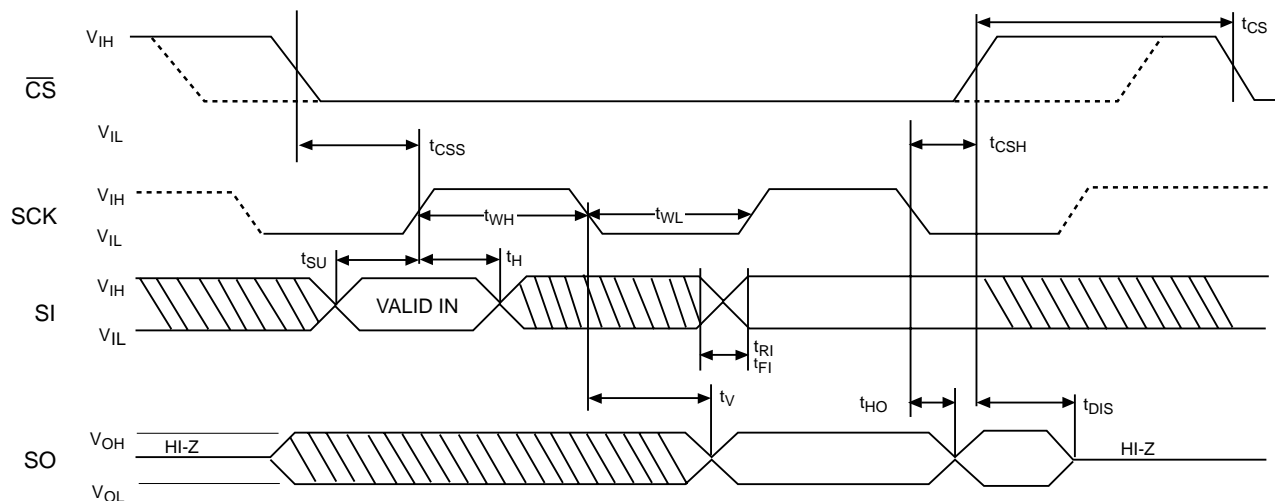

Note: Dashed Line = mode (1, 1) - - - - -

STATUS REGISTER

The Status Register, as shown in Table 2, contains a number of status and control bits.

The RDY (Ready) bit indicates whether the device is busy with a write operation. This bit is automatically set to 1 during an internal write cycle, and reset to 0 when the device is ready to accept commands. For the host, this bit is read only.

The WEL (Write Enable Latch) bit is set/reset by the WREN/WRDI commands. When set to 1, the device is

in a Write Enable state and when set to 0, the device is in a Write Disable state.

The BP0 and BP1 (Block Protect) bits determine which blocks are currently write protected. They are set by the user with the WRSR command and are non-volatile. The user is allowed to protect a quarter, one half or the entire memory, by setting these bits according to Table 3. The protected blocks then become read-only.

Table 2. Status Register

7	6	5	4	3	2	1	0
1	1	1	1	BP1	BP0	WEL	RDY

Table 3. Block Protection Bits

Status Register Bits		Array Address Protected	Protection
BP1	BP0		
0	0	None	No Protection
0	1	15002: C0-FF	Quarter Array Protection
		15004: 180-1FF	
1	0	15002: 80-FF	Half Array Protection
		15004: 100-1FF	
1	1	15002: 00-FF	Full Array Protection
		15004: 000-1FF	

WRITE OPERATIONS

The CAT15002/04 device powers up into a write disable state. The device contains a Write Enable Latch (WEL) which must be set before attempting to write to the memory array or to the status register. In addition, the address of the memory location(s) to be written must be outside the protected area, as defined by BP0 and BP1 bits from the status register.

take the CS input high after the WREN instruction, as otherwise the Write Enable Latch will not be properly set. WREN timing is illustrated in Figure 4. The WREN instruction must be sent prior any WRITE or WRSR instruction.

Write Enable and Write Disable

The internal Write Enable Latch and the corresponding Status Register WEL bit are set by sending the WREN instruction to the CAT15002/04. Care must be taken to

The internal write enable latch is reset by sending the WRDI instruction as shown in Figure 5. Disabling write operations by resetting the WEL bit, will protect the device against inadvertent writes.

Figure 4. WREN Timing

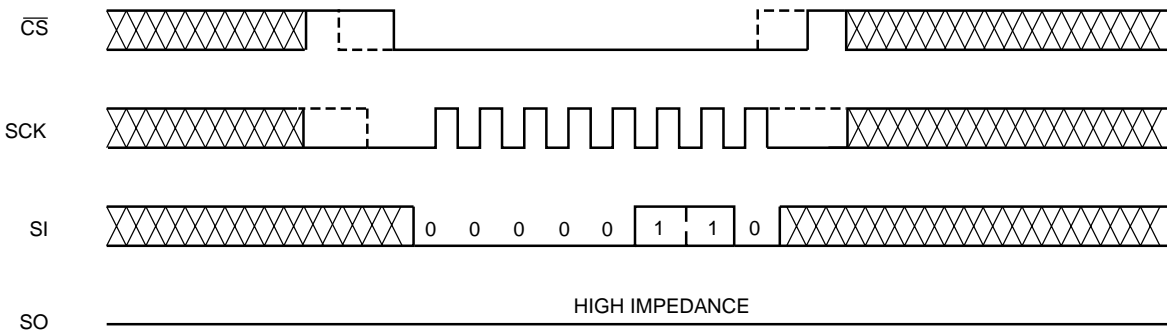

Note: Dashed Line = mode (1, 1) - - - - -

Figure 5. WRDI Timing

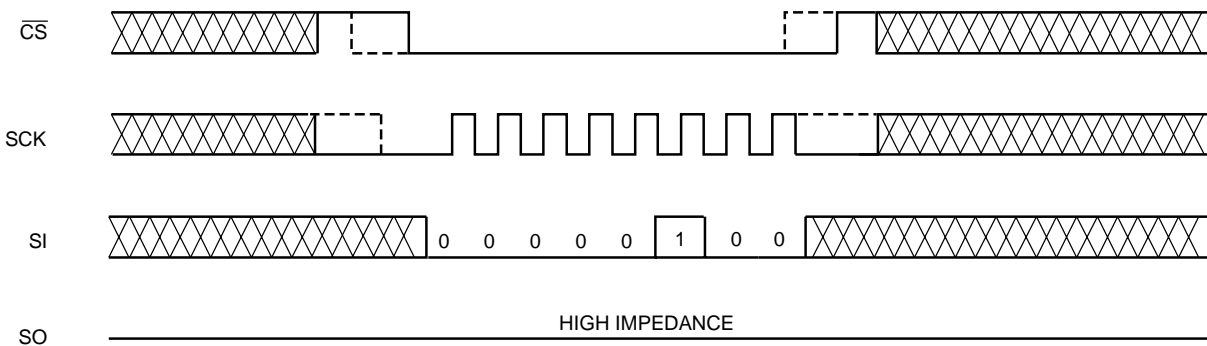

Note: Dashed Line = mode (1, 1) - - - - -

Byte Write

Once the WEL bit is set, the user may execute a write sequence, by sending a WRITE instruction, an 8-bit address and data as shown in Figure 6 (for the CAT15004, bit 3 of the Write instruction opcode contains address bit A8). Internal programming will start after the low to high CS transition. During an internal write cycle, all commands, except for RDSR (Read Status Register) will be ignored. The RDY bit will indicate if the internal write cycle is in progress (RDY high), or the the device is ready to accept commands (RDY low).

Page Write

After sending the first data byte to the CAT15002/04, the host may continue sending data, up to a total of 32 bytes, according to timing shown in Figure 7. After each data byte, the lower order address bits are automatically incremented, while the higher order address bits (page address) remain unchanged. If during this process the end of page is exceeded, then loading will “roll over” to the first byte in the page, thus possibly overwriting previously loaded data. Following completion of the write cycle, the CAT15002/04 is automatically returned to the write disable state.

Figure 6. Byte WRITE Timing

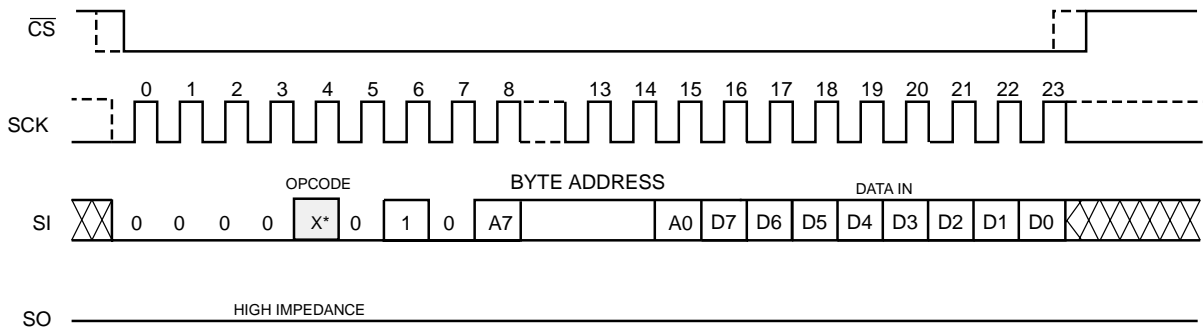

Notes:

* X = 0 for CAT15002; X = A8 for CAT15004

Dashed Line = mode (1, 1) - - - - -

Figure 7. Page WRITE Timing

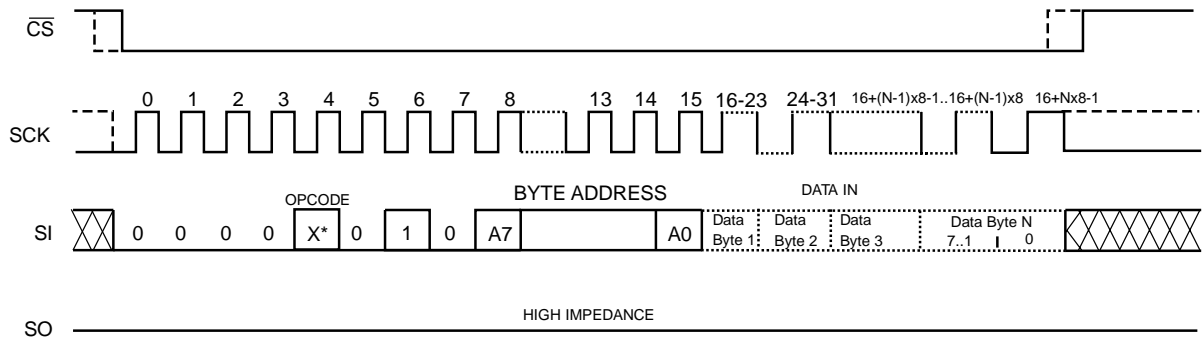

Notes:

* X = 0 for CAT15002; X = A8 for CAT15004

Dashed Line = mode (1, 1) - - - - -

Write Status Register

The Status Register is written by sending a WRSR instruction according to timing shown in Figure 8. Only bits 2 and 3 can be written using the WRSR command.

Write Protection

The Write Protect (WP) pin can be used to disable all write operations when held low. WP going low while CS is still low will interrupt a write to the CAT15002/04. If the internal write cycle has already been initiated, WP going low will have no effect on any write operation. The WP input timing is shown in Figure 9.

Figure 8. WRSR Timing

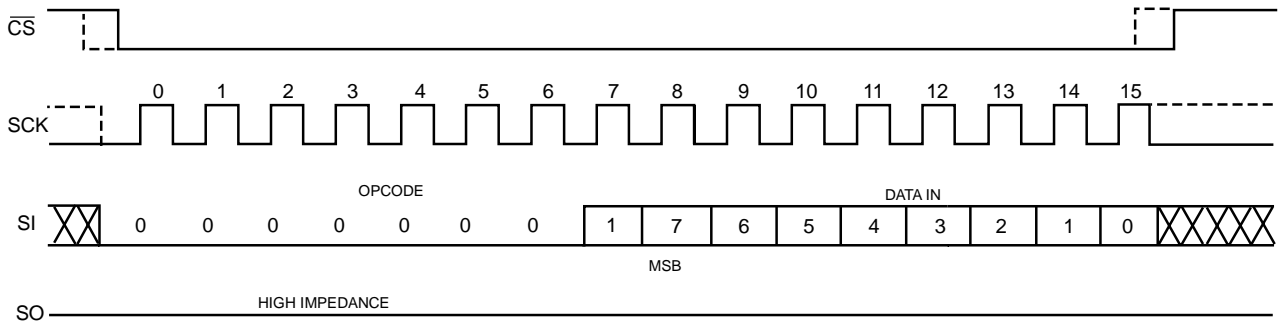

Note: Dashed Line = mode (1, 1) - - - - -

Figure 9. WP Timing

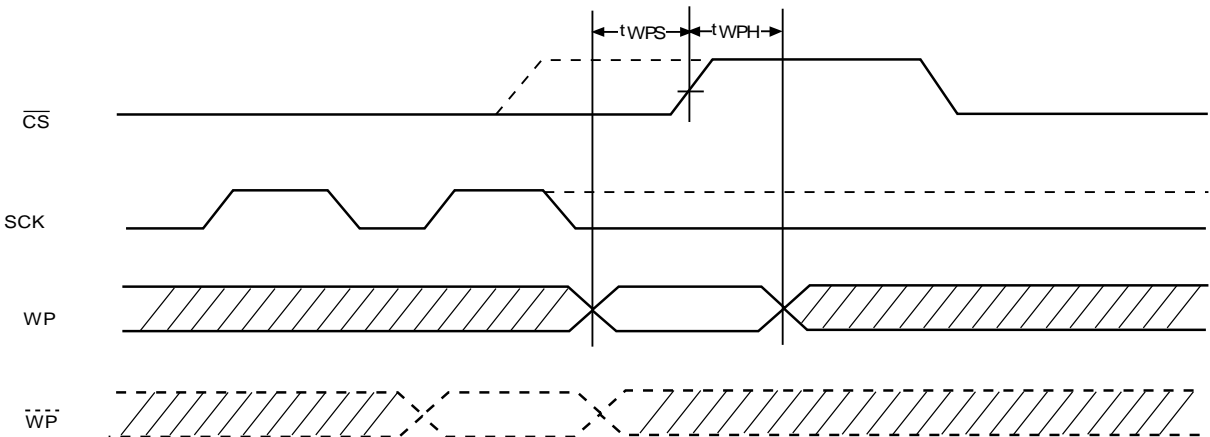

Note: Dashed Line = mode (1, 1) - - - - -

READ OPERATIONS

Read from Memory Array

To read from memory, the host sends a READ instruction followed by an 8-bit address (for the CAT15008, bit 3 of the Read instruction opcode contains address bit A8).

After receiving the last address bit, the CAT15002/04 will respond by shifting out data on the SO pin (as shown in Figure 10). Sequentially stored data can be read out by simply continuing to run the clock. The internal address pointer is automatically incremented to the next higher address as data is shifted out. After

reaching the highest memory address, the address counter “rolls over” to the lowest memory address, and the read cycle can be continued indefinitely. The read operation is terminated by taking CS high.

Read Status Register

To read the status register, the host simply sends a RDSR command. After receiving the last bit of the command, the CAT15002/04 will shift out the contents of the status register on the SO pin (Figure 11). The status register may be read at any time, including during an internal write cycle.

Figure 10. READ Timing

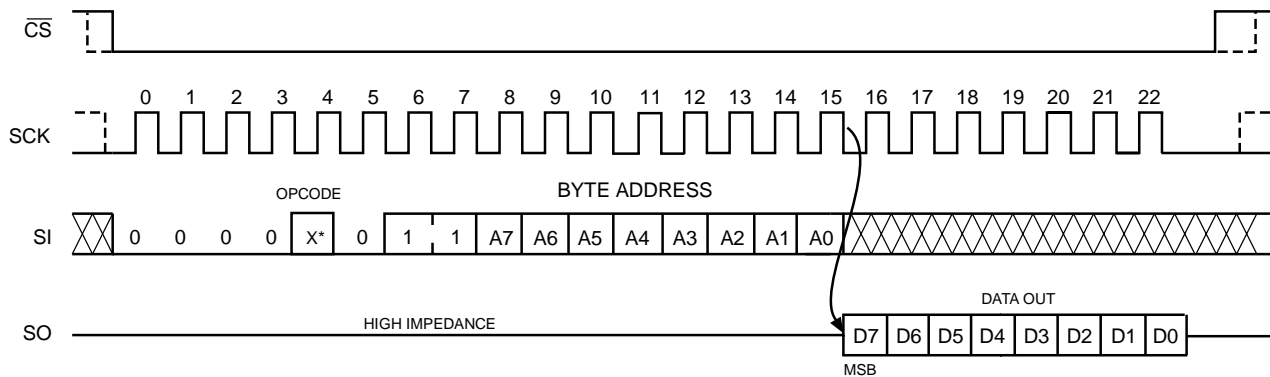

Notes:

* Please check the instruction set table for address

X = 0 for CAT15002; X=A8 for CAT15004

Dashed Line = mode (1, 1) - - - - -

Figure 11. RDSR Timing

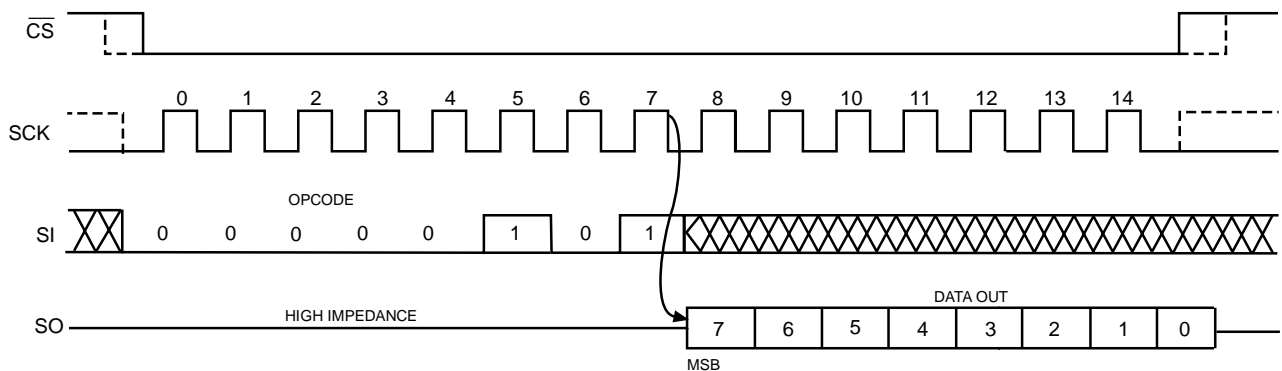

Note: Dashed Line = mode (1, 1) - - - - -

PACKAGE OUTLINE DRAWING

SOIC 8-Lead 150 mil (W)

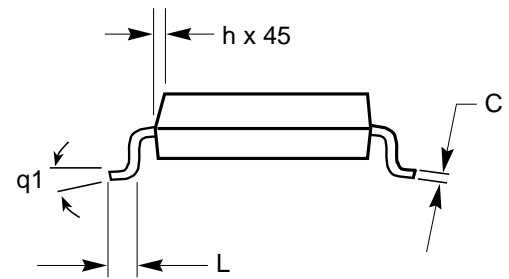
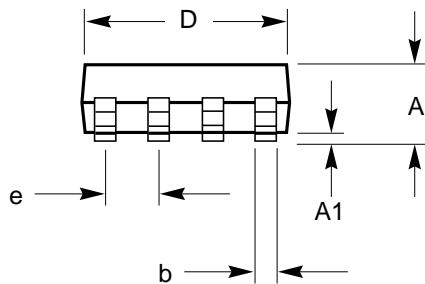
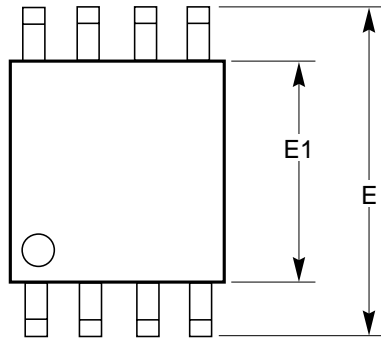

SYMBOL	MIN	NOM	MAX
A1	0.10		0.25
A	1.35		1.75
b	0.33		0.51
C	0.19		0.25
D	4.80		5.00
E	5.80		6.20
E1	3.80		4.00
e	1.27 BSC		
h	0.25		0.50
L	0.40		1.27
q1	0°		8°

Notes:

- (1) All dimensions are in millimeters.
- (2) Complies with JEDEC specification MS-012 dimensions.

PACKAGE MARKING

8-LEAD SOIC

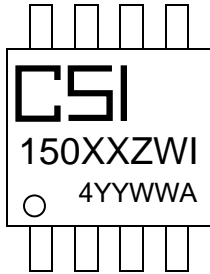

- CSI = Catalyst Semiconductor, Inc.
- XX = Device Code (see Marking Code table below)
- Z = Supervisory Output Code (see Marking Code table below)
- I = Temperature Range
- YY = Production Year
- WW = Production Week
- A = Product Revision
- 4 = Lead Finish NiPdAu

Device Marking Codes	
XX	
15002	02
15004	04

Supervisory Marking Codes	
Z	
output active low	9
output active high	1

EXAMPLE OF ORDERING INFORMATION

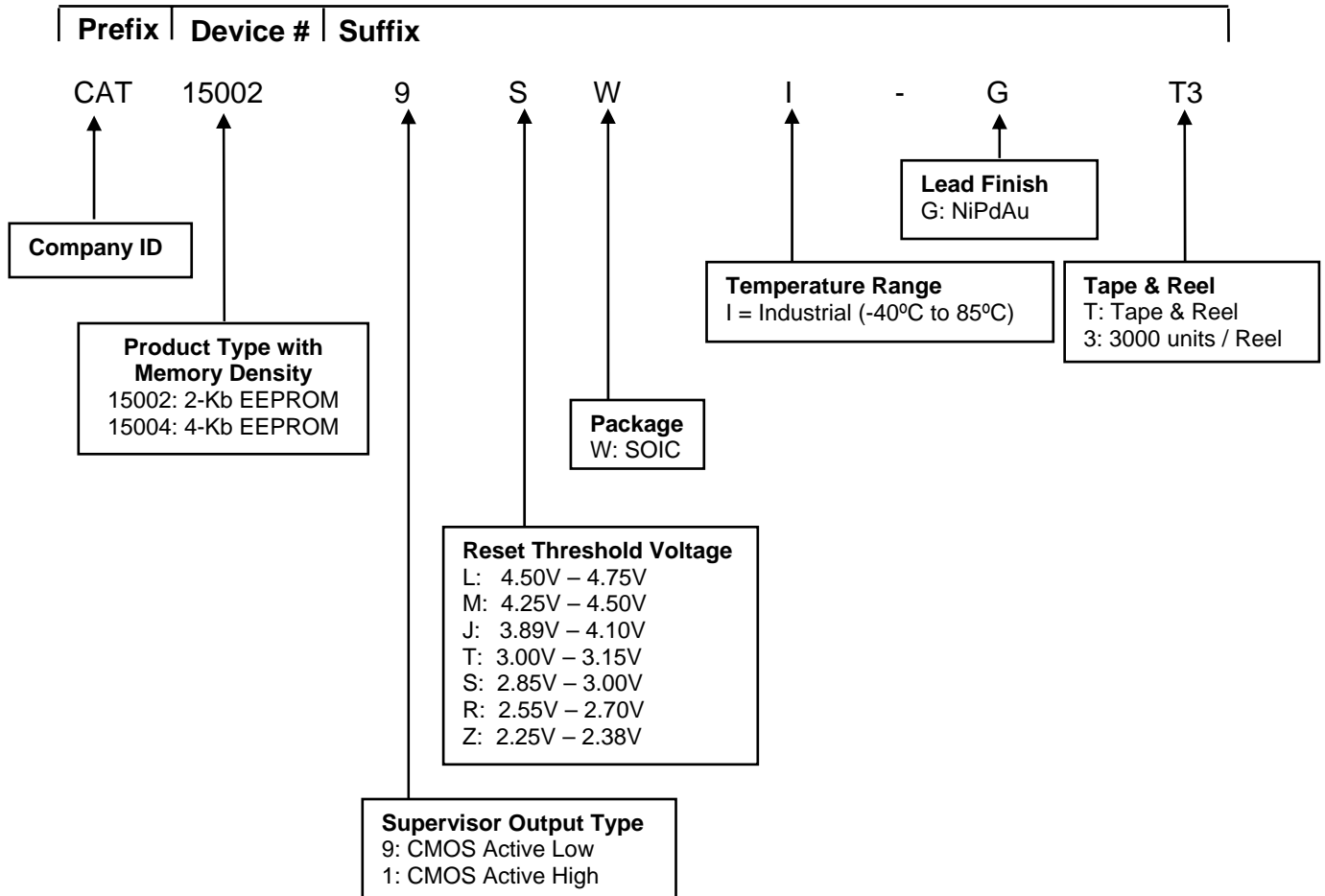

Notes:

- (1) All packages are RoHS-compliant (Lead-free, Halogen-free).
- (2) The standard lead finish is NiPdAu pre-plated (PPF) lead frames.
- (3) The device used in the above example is a CAT150029SWI-GT3 (2-Kb EEPROM, with Active Low CMOS Reset output, with a reset threshold between 2.85V - 3.00V, in SOIC package, Industrial Temperature, NiPdAu, Tape and Reel).
- (4) For additional package and temperature options, please contact your nearest ON Semiconductor Sales office.

REVISION HISTORY

Date	Rev.	Description
16-Jan-07	A	Initial Issue
10-Nov-08	B	Change logo and fine print to ON Semiconductor

ON Semiconductor and  are registered trademarks of Semiconductor Components Industries, LLC (SCILLC). SCILLC reserves the right to make changes without further notice to any products herein. SCILLC makes no warranty, representation or guarantee regarding the suitability of its products for any particular purpose, nor does SCILLC assume any liability arising out of the application or use of any product or circuit, and specifically disclaims any and all liability, including without limitation special, consequential or incidental damages. "Typical" parameters which may be provided in SCILLC data sheets and/or specifications can and do vary in different applications and actual performance may vary over time. All operating parameters, including "Typicals" must be validated for each customer application by customer's technical experts. SCILLC does not convey any license under its patent rights nor the rights of others. SCILLC products are not designed, intended, or authorized for use as components in systems intended for surgical implant into the body, or other applications intended to support or sustain life, or for any other application in which the failure of the SCILLC product could create a situation where personal injury or death may occur. Should Buyer purchase or use SCILLC products for any such unintended or unauthorized application, Buyer shall indemnify and hold SCILLC and its officers, employees, subsidiaries, affiliates, and distributors harmless against all claims, costs, damages, and expenses, and reasonable attorney fees arising out of, directly or indirectly, any claim of personal injury or death associated with such unintended or unauthorized use, even if such claim alleges that SCILLC was negligent regarding the design or manufacture of the part. SCILLC is an Equal Opportunity/Affirmative Action Employer. This literature is subject to all applicable copyright laws and is not for resale in any manner.

PUBLICATION ORDERING INFORMATION

LITERATURE FULFILLMENT:

Literature Distribution Center for ON Semiconductor
P.O. Box 5163, Denver, Colorado 80217 USA
Phone: 303-675-2175 or 800-344-3860 Toll Free USA/Canada
Fax: 303-675-2176 or 800-344-3867 Toll Free USA/Canada
Email: orderlit@onsemi.com

N. American Technical Support: 800-282-9855 Toll Free
USA/Canada
Europe, Middle East and Africa Technical Support:
Phone: 421 33 790 2910
Japan Customer Focus Center:
Phone: 81-3-5773-3850

ON Semiconductor Website: www.onsemi.com
Order Literature: <http://www.onsemi.com/orderlit>
For additional information, please contact your local Sales Representative