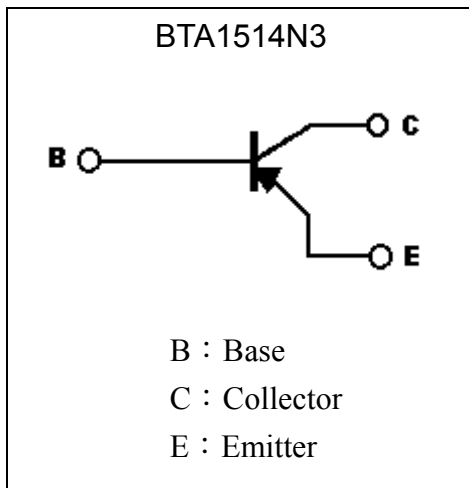
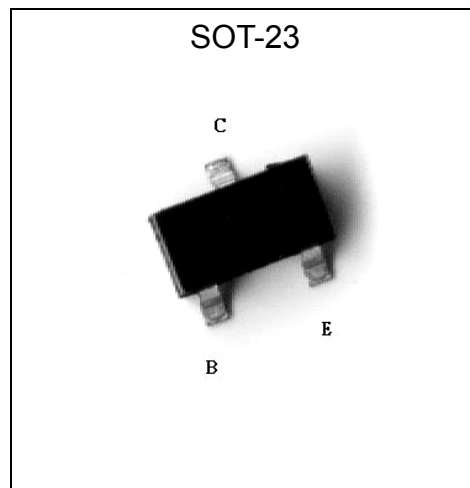

General Purpose PNP Epitaxial Planar Transistor

BTA1514N3

Description

- The BTA1514N3 is designed for general purpose application requiring high breakdown voltage.
- Large I_C , $I_{C(Max)}$ = -0.6A
- High BV_{CEO} , BV_{CEO} = -150V
- Complementary to BTC3906N3.
- Pb-free package

Symbol

Outline

Absolute Maximum Ratings ($T_a=25^\circ\text{C}$)

Parameter	Symbol	Limits	Unit
Collector-Base Voltage	V_{CBO}	-160	V
Collector-Emitter Voltage	V_{CEO}	-150	V
Emitter-Base Voltage	V_{EBO}	-5	V
Collector Current	I_C	-0.6	A
Power Dissipation	P_d	225	mW
Thermal Resistance, Junction to Ambient	$R_{\theta JA}$	556	$^\circ\text{C}/\text{W}$
Junction Temperature	T_j	150	$^\circ\text{C}$
Storage Temperature	T_{stg}	-55~+150	$^\circ\text{C}$

**Characteristics (Ta=25°C)**

Symbol	Min.	Typ.	Max.	Unit	Test Conditions
BVCBO	-160	-	-	V	IC=-50μA
BVCEO	-150	-	-	V	IC=-1mA
BVEBO	-5	-	-	V	IE=-50μA
ICBO	-	-	-50	nA	VCB=-120V
IEBO	-	-	-50	nA	VEB=-4V
*VCE(sat) 1	-	-	-0.2	V	IC=-10mA, IB=-1mA
*VCE(sat) 2	-	-	-0.5	V	IC=-50mA, IB=-5mA
*VBE(sat) 1	-	-	-1	V	IC=-10mA, IB=-1mA
*VBE(sat) 2	-	-	-1	V	IC=-50mA, IB=-5mA
hFE 1	50	-	-	-	VCE=-5V, IC=-1mA
hFE 2	60	-	-	-	VCE=-5V, IC=-10mA
hFE 3	50	-	-	-	VCE=-5V, IC=-50mA
hFE 4	120	-	390	-	VCE=-6V, IC=-2mA
fT	100	-	-	MHz	VCE=-30V, IC=-10mA, f=100MHz
Cob	-	-	6	pF	VCB=-10V, f=1MHz

*Pulse Test: Pulse Width ≤380μs, Duty Cycle≤2%

Classification Of hFE 4

Rank	Q	R
Range	120~270	180~390

Ordering Information

Device	Package	Shipping	Marking
BTA1514N3	SOT-23 (Pb-free)	3000 pcs / Tape & Reel	2L



Characteristic Curves

Current Gain vs Collector Current

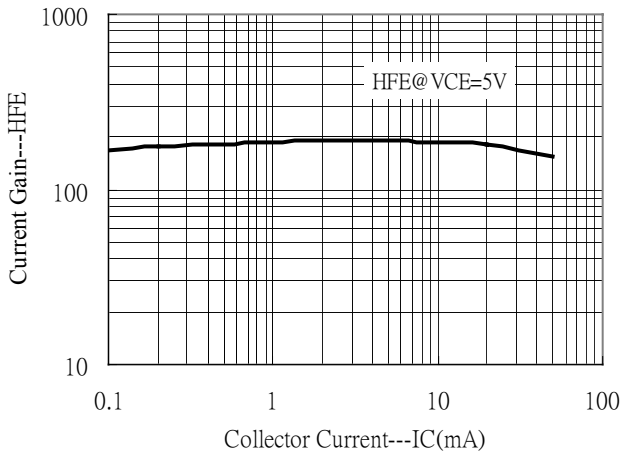

Saturation Voltage vs Collector Current

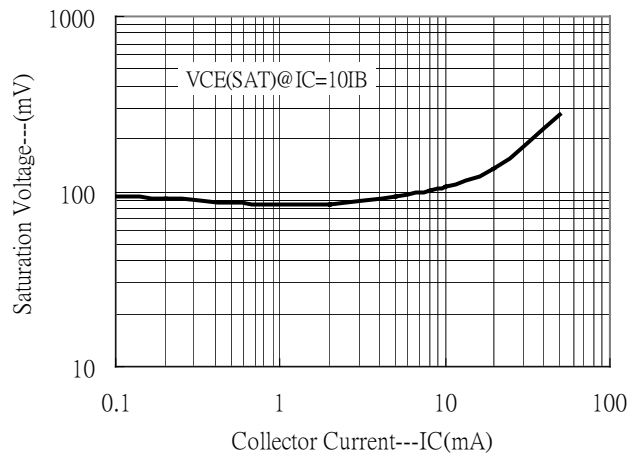

Saturation Voltage vs Collector Current

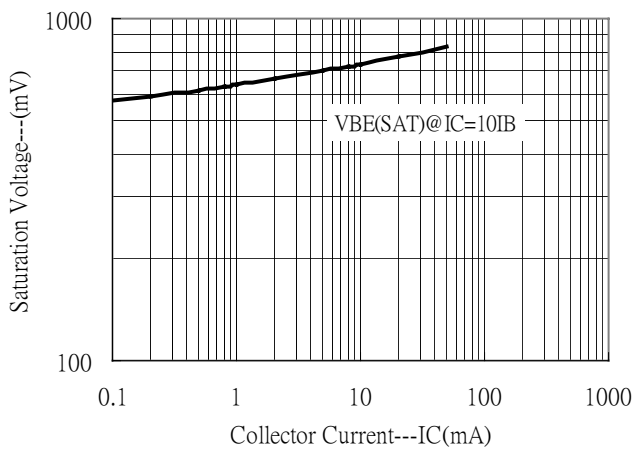

Cutoff Frequency vs Collector Current

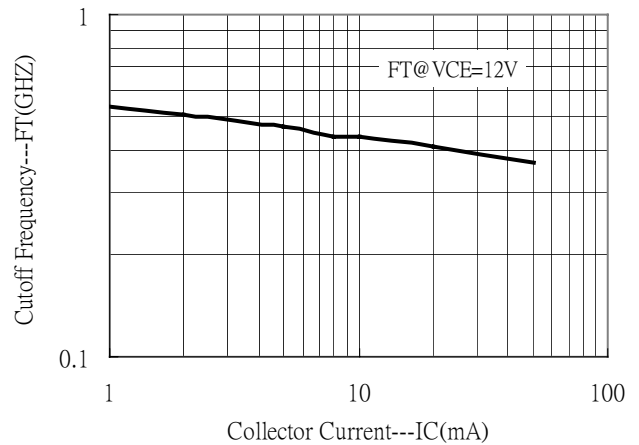

Power Derating Curve

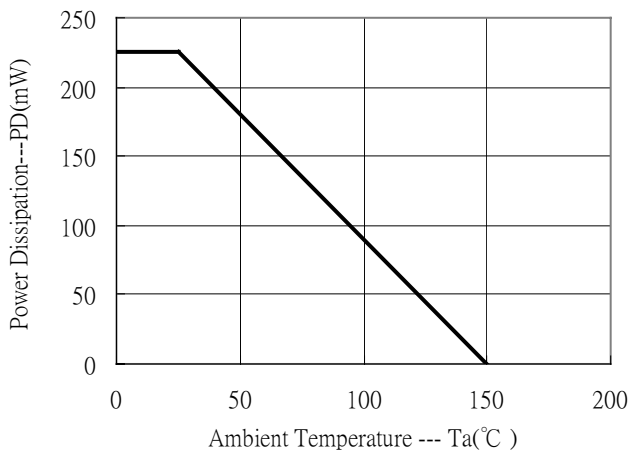

Reel Dimension

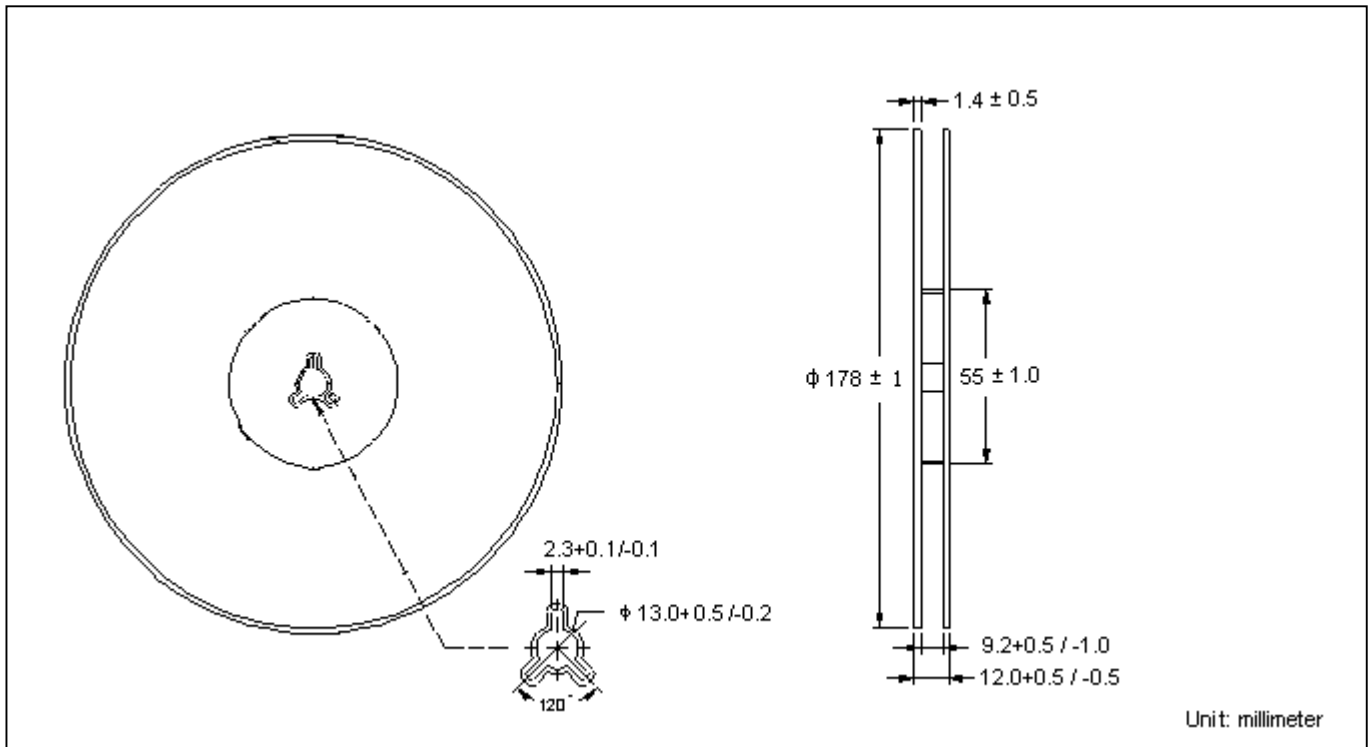

Carrier Tape Dimension

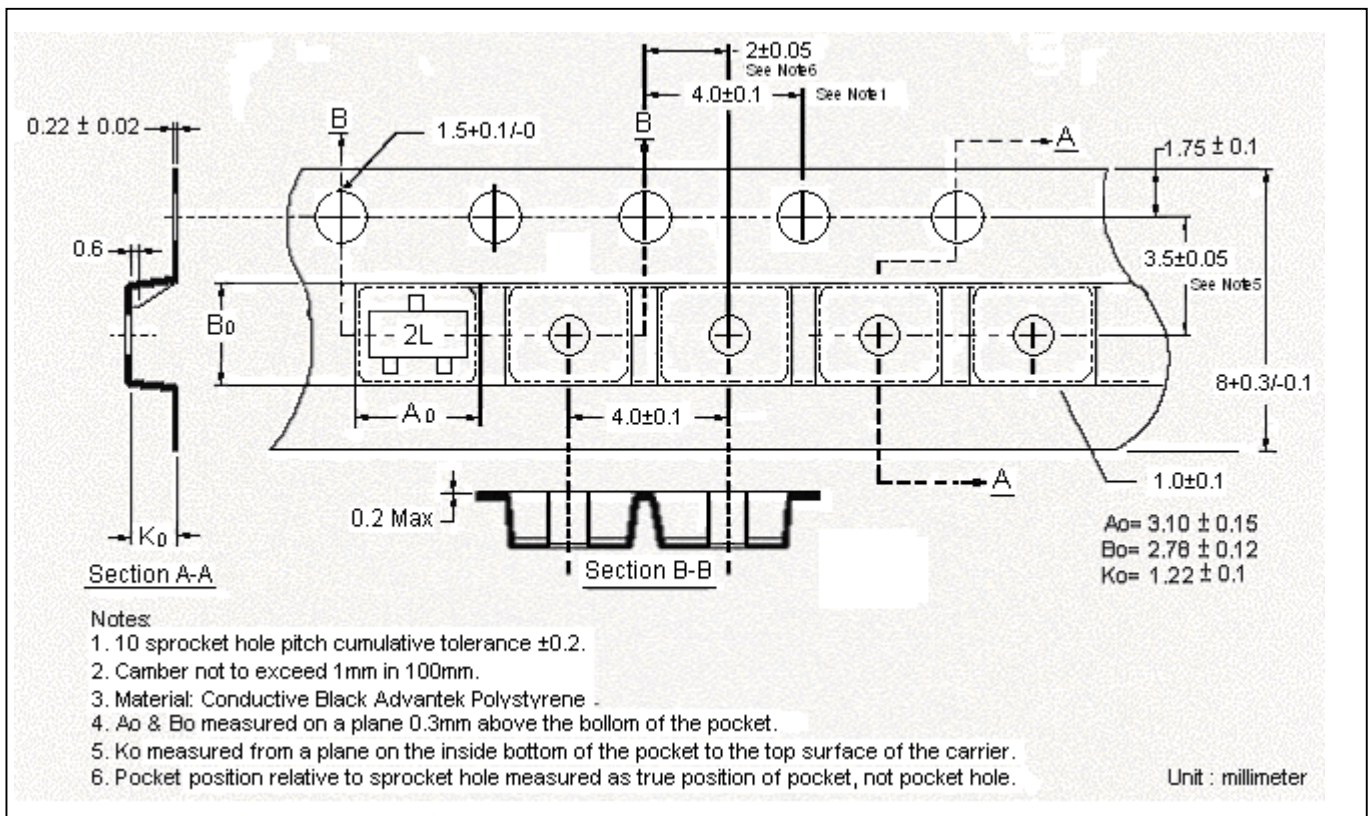

SOT-23 Dimension

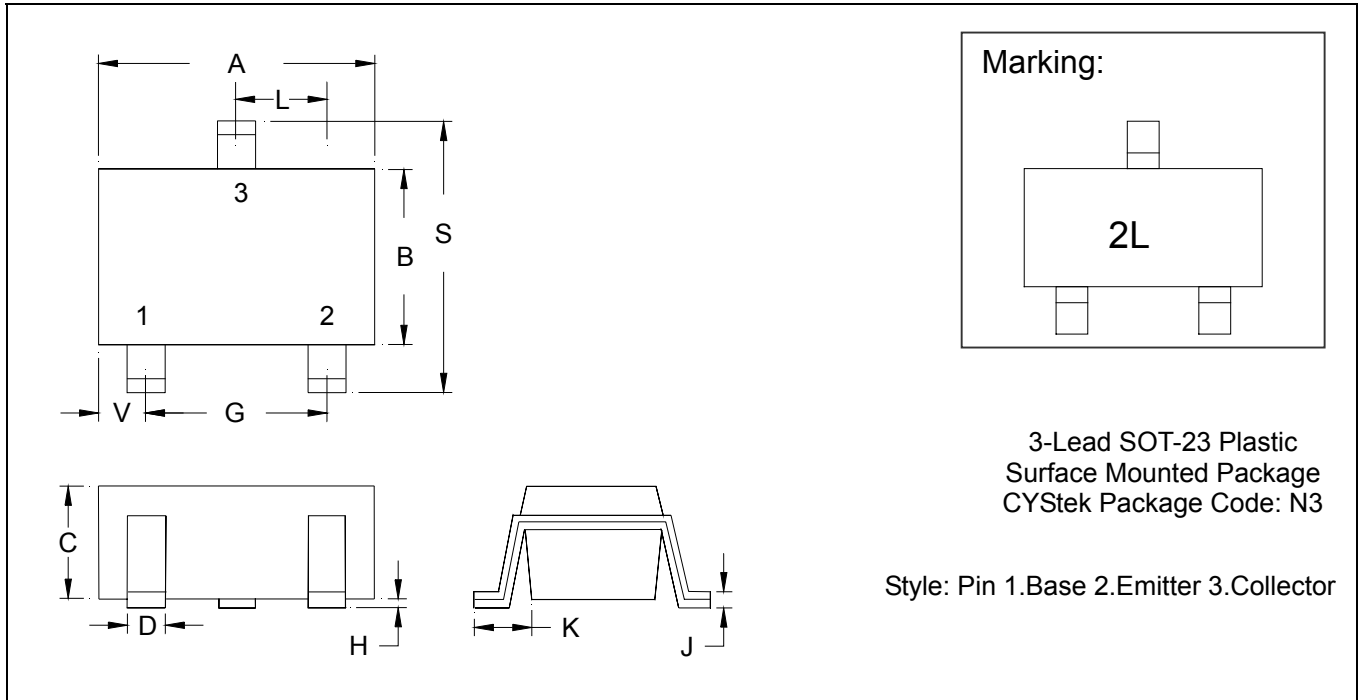

*: Typical

DIM	Inches		Millimeters		DIM	Inches		Millimeters	
	Min.	Max.	Min.	Max.		Min.	Max.	Min.	Max.
A	0.1102	0.1204	2.80	3.04	J	0.0034	0.0070	0.085	0.177
B	0.0472	0.0630	1.20	1.60	K	0.0128	0.0266	0.32	0.67
C	0.0335	0.0512	0.89	1.30	L	0.0335	0.0453	0.85	1.15
D	0.0118	0.0197	0.30	0.50	S	0.0830	0.1083	2.10	2.75
G	0.0669	0.0910	1.70	2.30	V	0.0098	0.0256	0.25	0.65
H	0.0005	0.0040	0.013	0.10					

Notes: 1.Controlling dimension: millimeters.
 2.Maximum lead thickness includes lead finish thickness, and minimum lead thickness is the minimum thickness of base material.
 3.If there is any question with packing specification or packing method, please contact your local CYStek sales office.

Material:

- Lead: 42 Alloy ; solder plating
- Mold Compound: Epoxy resin family, flammability solid burning class: UL94V-0

Important Notice:

- All rights are reserved. Reproduction in whole or in part is prohibited without the prior written approval of CYStek.
- CYStek reserves the right to make changes to its products without notice.
- CYStek **semiconductor products are not warranted to be suitable for use in Life-Support Applications, or systems.**
- CYStek assumes no liability for any consequence of customer product design, infringement of patents, or application assistance.