

T B 3 1 2 5 1 F L

1.4 GHz DUAL-PLL FREQUENCY SYNTHESIZER

This PLL frequency synthesizer is designed for use in digital mobile radio communications. It contains two channels of PLL circuits which can be controlled independently of each other.

FEATURES

- Operating frequency PLL1 : 500 to 1400 MHz
PLL2 : 500 to 1400 MHz
- Current consumption
 - When operating in full : 6.0 mA (Typ.)
 - PLL1 : 3.0 mA (Typ.)
 - PLL2 : 3.0 mA (Typ.)
- Operating voltage range : 2.4 to 3.6 V
- Independent power-down (battery-saving) mode is possible
- Compact package : 16-pin QON (0.65 mm pitch)

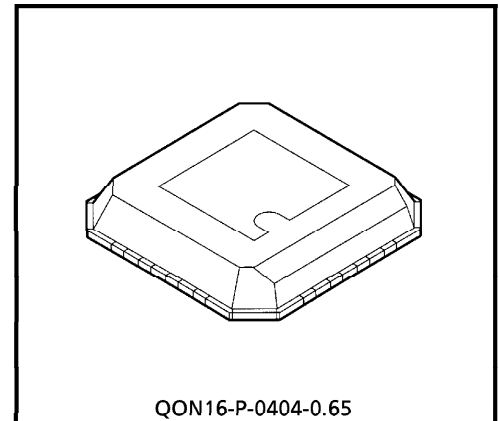

QON16-P-0404-0.65

Weight : 0.04 g (Typ.)

Abbreviated marked on product : B05

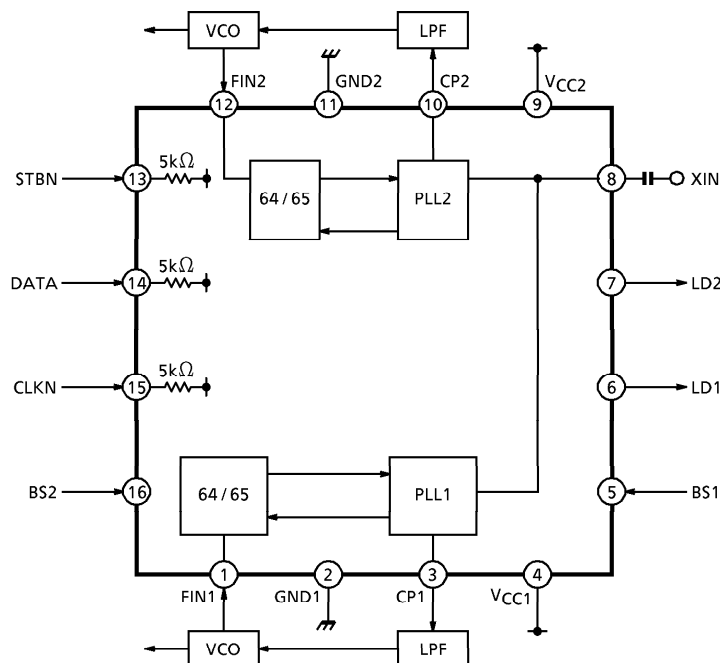

Handle with care to prevent devices from deterioration by static electricity.

PIN FUNCTION (The values of resistor and capacitor are typical.)

PIN No.	PIN NAME	FUNCTION	INTERNAL EQUIVALENT CIRCUIT (PIN PERIPHERY)
1	FIN1	Prescaler input for PLL1. Use a VCO-oscillated frequency for this input.	
2	GND1	Ground.	—
3	CP1	PLL1 charge pump output. This is a constant-current output type.	
4	VCC1	Power supply.	—
6	LD1	PLL1 lock detection output. This output is an NMOS open-drain type. Locked state : Open, Unlocked state : Low, Power-down state : Open	
7	LD2	PLL2 lock detection output. This output is an NMOS open-drain type. Locked state : Open, Unlocked state : Low, Power-down state : Open	
9	VCC2	Power supply.	—
10	CP2	PLL2 charge pump output. This is a constant-current output type.	
8	XIN	Oscillator input.	
11	GND2	Ground.	—

PIN No.	PIN NAME	FUNCTION	INTERNAL EQUIVALENT CIRCUIT (PIN PERIPHERY)
12	FIN2	Prescaler input for PLL2. Use a VCO-oscillated frequency for this input.	
13	STBN	Strobe input. (Pull-up resistor included, 5kΩ)	
14	DATA	Data input. (Pull-up resistor included, 5kΩ)	
15	CLKN	Clock input. (Pull-up resistor included, 5kΩ)	
5	BS1	Battery save for PLL1	
16	BS2	Battery save for PLL2	

DESCRIPTION

(1) Serial Data Input

The operation of this IC is controlled by a serial data program. Use the clock (CLK), data (DATA), and strobe (STB) pins to input the serial data.

(2) Method for Entering Serial Data

- The data is forwarded into the IC's internal shift register sequentially beginning with the LSB in synchronism with rising edges of the clock pulse. When all bits of data are forwarded, drive the strobe pin high. The data is latched in the appropriate place according to each content of control by a rising edge of this strobe signal. Control is initiated simultaneously when the data is stored in this place.
- The clock, data, and strobe pins each contain a Schmitt trigger circuit to eliminate noise-induced erroneous operation.
- At power-on, be sure to transmit option control before sending divide-by-n data.

(3) Serial Data Input Timing

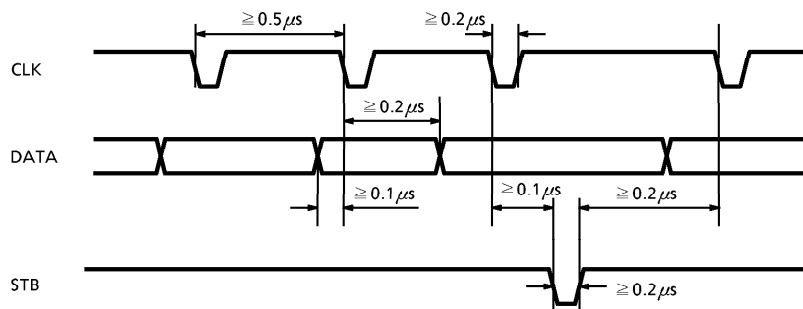

(4) Group Code

- The serially input data is grouped by the last 3 bits code.

Bit Before Preceding One	Previous Bit	Last Bit	Content of Control
0	1	0	Divide-by number for PLL1 programmable divider
0	0	1	Divide-by number for PLL2 programmable divider
0	1	1	Divide-by number for PLL1 reference divider
1	1	1	Divide-by number for PLL2 reference divider
0	0	0	Option control

(5) PLL1 Divide-by Data (21 bits)

- PLL1 is comprised of a 6-bit swallow counter (programmable counter), a 11-bit programmable counter, and a 2-modulus (1/64 and 1/65) prescaler.
- By sending data to the swallow and programmable counters, any desired divide-by number can be set in the range of 4,032 to 131,071.

PLL1

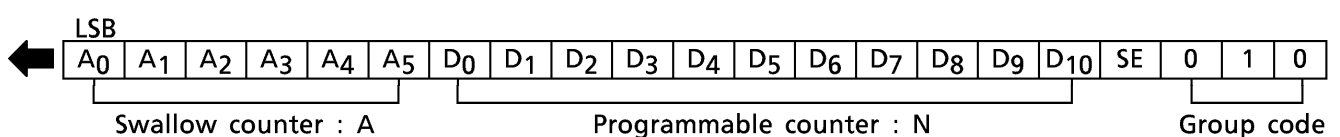

Divide-by number = 64N + A

$$A = A_0 + A_1 \times 2^1 + \dots + A_5 \times 2^5$$

$$N = D_0 + D_1 \times 2^1 + \dots + D_{10} \times 2^{10}$$

$$4032 \leq \text{divide-by number} \leq 131071$$

A : Value of counter A (remainder)
 N : Value of counter N (quotient)

SE	Frame structure
0	4 frames
1	5 frames

(6) PLL2 Divide-by Data (21 bits)

- PLL2 consists of a 6-bit swallow counter (programmable counter), a 11-bit programmable counter, and a 2-modulus (1/64 and 1/65) prescaler.
- By sending data to the swallow and programmable counters, any desired divide-by number can be set in the range of 4032 to 131071.

PLL2

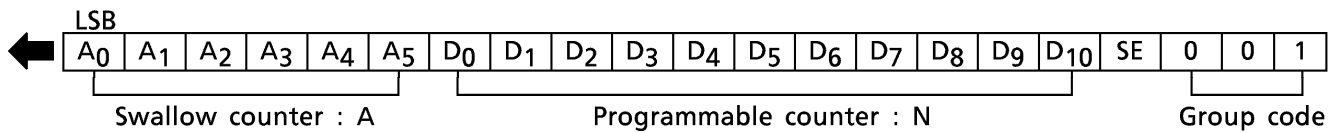

Divide-by number = 64N + A

$$A = A_0 + A_1 \times 2^1 + \dots + A_5 \times 2^5$$

$$N = D_0 + D_1 \times 2^1 + \dots + D_{10} \times 2^{10}$$

$$4032 \leq \text{divide-by number} \leq 131071$$

A : Value of counter A (remainder)
 N : Value of counter N (quotient)

SE	Frame structure
0	4 frames
1	5 frames

(7) PLL1 Reference Divider (19 bits)

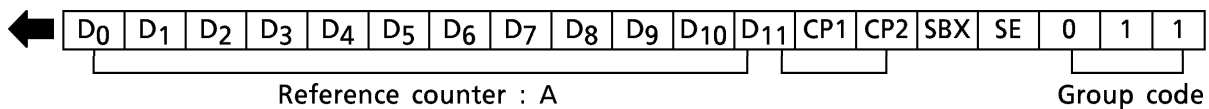

$$D = D_0 + D_1 \times 2^1 + \dots + D_9 \times 2^9 + D_{10} \times 2^{10} + D_{11} \times 2^{11}$$

$$4 \leq \text{divide-by number} \leq 4095$$

SE	Frame structure
0	4 frames
1	5 frames

CP1	CP2	CP1 Output Current
0	0	0.25mA
0	1	0.5mA
1	0	1.0mA
1	1	2.0mA

(8) PLL2 Reference Divider (19 bits)

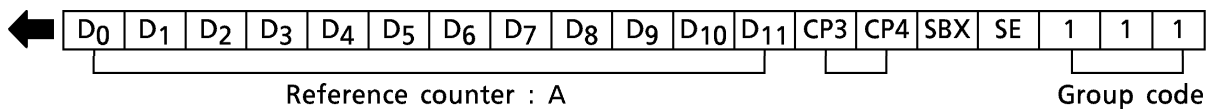

$$D = D_0 + D_1 \times 2^1 + \dots + D_9 \times 2^9 + D_{10} \times 2^{10} + D_{11} \times 2^{11}$$

4 ≤ divide-by number ≤ 4095

SE	Frame structure
0	4 frames
1	5 frames

CP3	CP4	CP2 Output Current
0	0	0.25mA
0	1	0.5mA
1	0	1.0mA
1	1	2.0mA

(9) Option Control

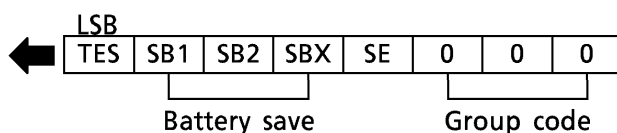

● Power-down mode

The PLL1, PLL2, and XIN can be switched between the power-down mode and operating state by using external battery save pins-BS1 and BS2-and the SB1, SB2, and SBX bits. This power-down mode is controlled in connection with the SB1 and SB2 bits as shown in the table below.

External Pin		Serial Data				Operating State		
BS1	BS2	SB1	SB2	SBX	SE	PLL1	PLL2	XIN
L	L	*	*	0	*	OFF	OFF	OFF
L	L	*	*	1	*	OFF	OFF	ON
L	H	*	*	*	*	OFF	ON	ON
H	L	*	*	*	*	ON	OFF	ON
H	H	*	*	*	0	ON	ON	ON
H	H	0	0	0	1	OFF	OFF	OFF
H	H	0	0	1	1	OFF	OFF	ON
H	H	0	1	*	1	OFF	ON	ON
H	H	1	0	*	1	ON	OFF	ON
H	H	1	1	*	1	ON	ON	ON

ON = Operating state ; OFF = Power-down state (Not operating), * = Don't Care

● Lock detection

When a phase error (in terms of time) falls within one TCXO count, the lock detection output timer is started. After 7 counts of phase comparison, the timer outputs a "locked" signal (high). When a phase error (in terms of time) becomes greater than one TCXO count, the timer outputs an "unlocked" signal (low).

Locked state = High ; Unlocked state = Low ; Power-down state = High.

MAXIMUM RATING (Ta = 25°C)

CHARACTERISTIC	SYMBOL	RATING	UNIT
Supply Voltage	V _{CC}	4	V
Power Dissipation	P _D	240	mW
Input Pin Voltage	V _{IN}	-0.5~4	V
LD Pin Sink Current	ILD-SINK	3	mA
Operating Temperature Range	V _{opr}	-40~85	°C
Storage Temperature Range	V _{stg}	-55~150	°C

ELECTRICAL CHARACTERISTICS (Unless otherwise specified, V_{CC} = 3.0V, Ta = 25°C)

CHARACTERISTIC	SYMBOL	TEST CIRC UIT	TEST CONDITION	MIN	TYP.	MAX	UNIT
Operating Supply Voltage	V _{CC}	1		2.4	3.0	3.6	V
Current Consumption During No Signal 1~4	I _{cco1}	1	During full operation	—	6.0	7.5	mA
	I _{cco2}	1	BS1 = H, BS2 = L	—	3.0	4.0	mA
	I _{cco3}	1	BS1 = L, BS2 = H	—	3.0	4.0	mA
	I _{cco4}	1	BS1 = L, BS2 = L, SBX = 1	—	0.3	0.6	mA
Current Consumption During BS	I _{ccoq}	1	BS1 = L, BS2 = L, SBX = 0	—	0	10	μA
Operating Frequency (PLL1)	F _{IN1}	2	V _{FIN1} = 92dBμV	500	—	1400	MHz
Operating Frequency (PLL2)	F _{IN2}	2	V _{FIN2} = 92dBμV	500	—	1400	MHz
FIN1 Input Level	V _{FIN1}	2	F _{IN1} = 500~1400MHz	92	—	107	dBμV
FIN2 Input Level	V _{FIN2}	2	F _{IN2} = 500~1400MHz	92	—	107	dBμV
Reference Operating Frequency	F _{XIN}	2	V _{XIN} = 97dBμV	5	—	20	MHz
Reference Input Voltage	V _{XIN}	2	F _{XIN} = 5~20MHz	97	—	110	dBμV
Clock Input Frequency	—	—		1	500	2000	kHz
Pull-up Resistance (Serial Data)	R _{SD}	—	CLKN, DATA, STBN	4.25	5	5.75	kΩ

CHARACTERISTIC	SYMBOL	TEST CIRCUIT	TEST CONDITION	MIN	TYP.	MAX	UNIT
Charge Pump Output Current (PLL1)	ICP1	1	CP1 = 0, CP2 = 0	0.21	0.25	0.29	mA
			CP1 = 0, CP2 = 1	0.42	0.5	0.58	mA
			CP1 = 1, CP2 = 0	0.85	1.0	1.15	mA
			CP1 = 1, CP2 = 1	1.7	2.0	2.3	mA
Charge Pump Output Current (PLL2)	ICP2	1	CP3 = 0, CP4 = 0	0.21	0.25	0.29	mA
			CP3 = 0, CP4 = 1	0.42	0.5	0.58	mA
			CP3 = 1, CP4 = 0	0.85	1.0	1.15	mA
			CP3 = 1, CP4 = 1	1.7	2.0	2.3	mA
Charge Pump Output Off-Leakage	ICP (OFF)	1	$V_{CP} = 1/2 V_{CC}$	-0.1	0	0.1	nA
High Level Input Voltage	V_{IH}	—	BS1, BS2, CLK, DATA, STB	$0.8 \times V_{CC}$	—	4.0	V
Low Level Input Voltage	V_{IL}	—	BS1, BS2, CLK, DATA, STB	GND	—	$0.2 \times V_{CC}$	V
LD Pin Off-Leakage	ILD	1	$V_{LD} = 3.6V$	-1	0	1	μA
LD Pin On-Resistance	RLD (ON)	1	$V_{LD} = 0.4V$	—	1	1.5	k Ω

TEST CIRCUIT 1

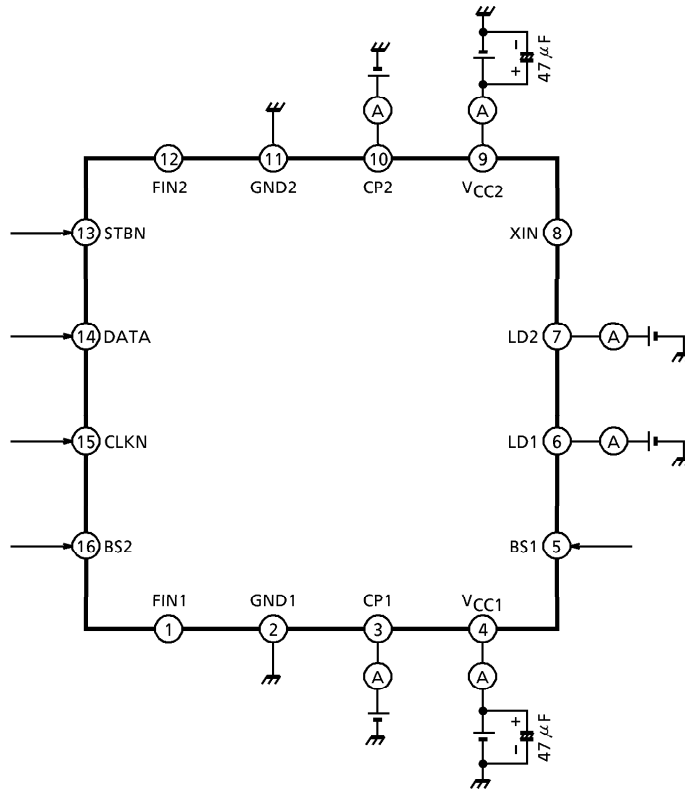

TEST CIRCUIT 2

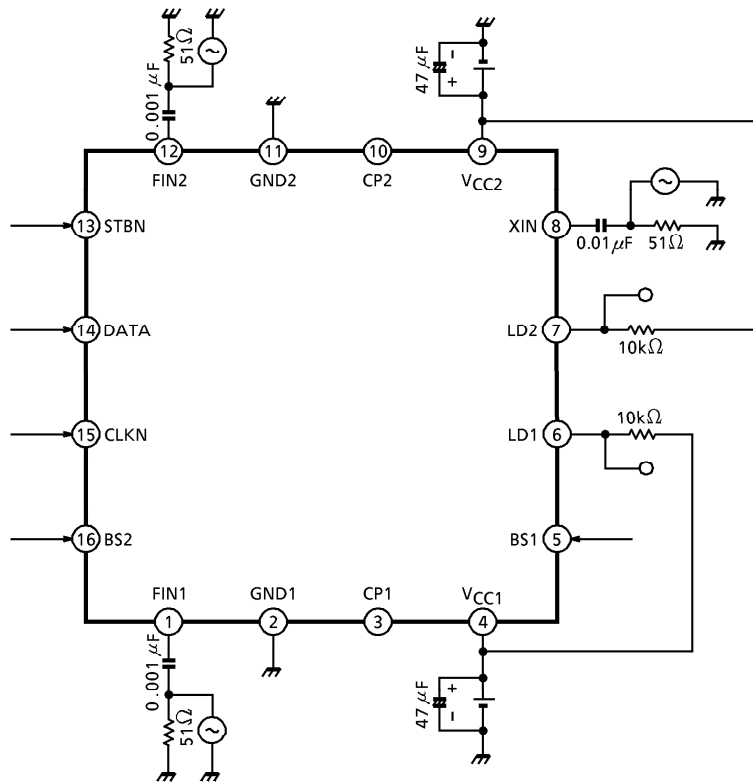

V_{CC}-I_{CC} CHARACTERISTICS

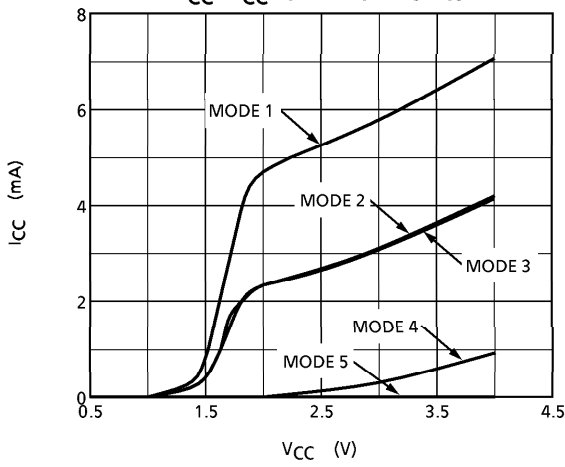

	PLL1	PLL2	Xin
MODE 1	ON	ON	ON
MODE 2	OFF	ON	ON
MODE 3	ON	OFF	ON
MODE 4	OFF	OFF	ON
MODE 5	OFF	OFF	OFF

V_{cp}-I_{cp} CHARACTERISTICS PLL1 Pch

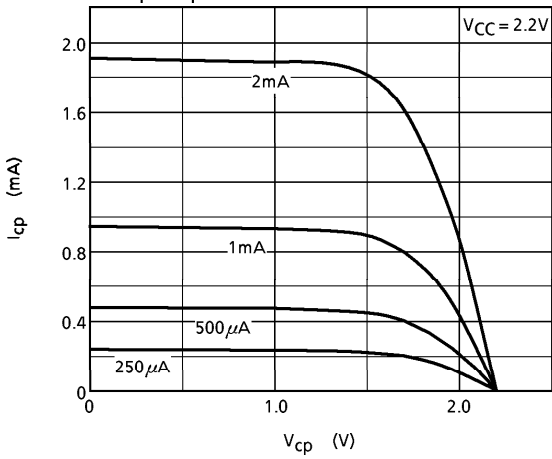

V_{cp}-I_{cp} CHARACTERISTICS PLL2 Pch

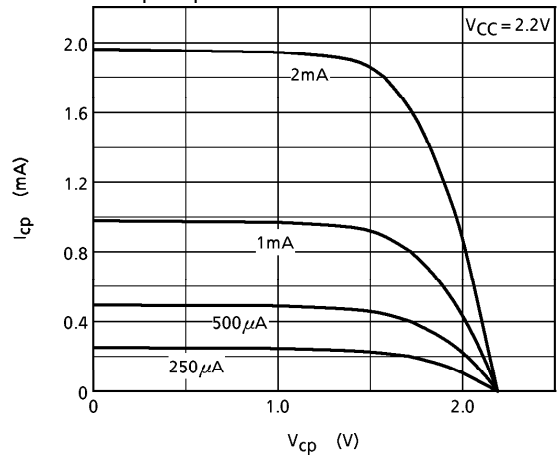

V_{cp}-I_{cp} CHARACTERISTICS PLL1 Nch

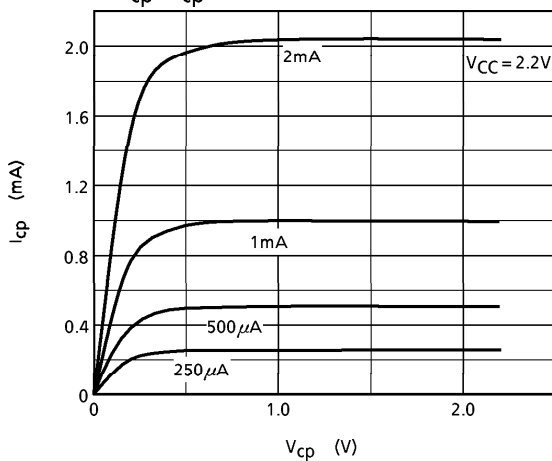

V_{cp}-I_{cp} CHARACTERISTICS PLL2 Nch

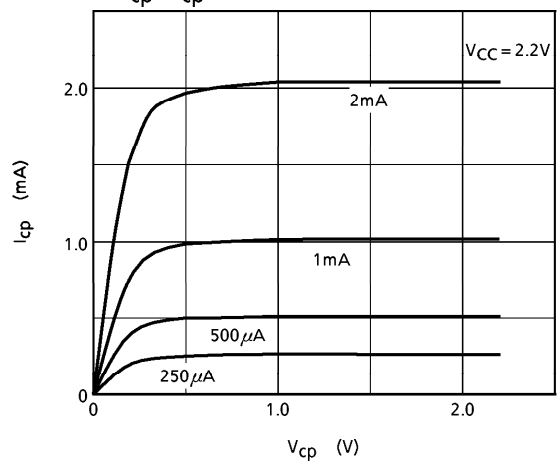

V_{cp} - I_{cp} CHARACTERISTICS PLL1 Pch

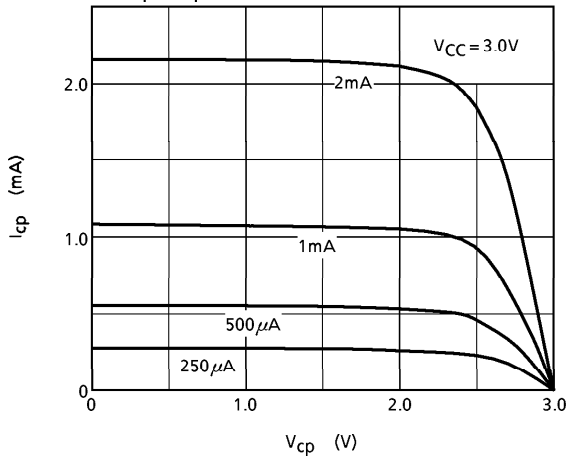

V_{cp} - I_{cp} CHARACTERISTICS PLL2 Pch

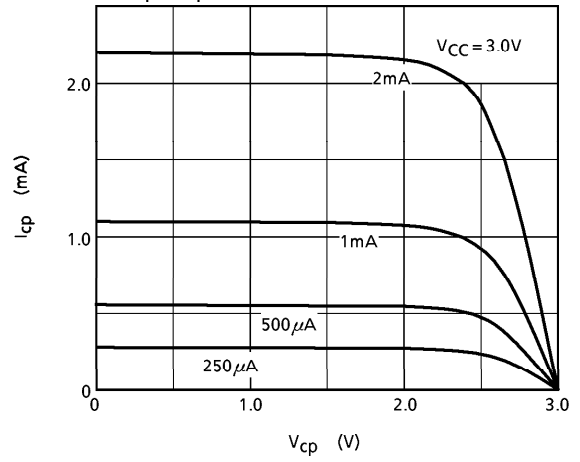

V_{cp} - I_{cp} CHARACTERISTICS PLL1 Nch

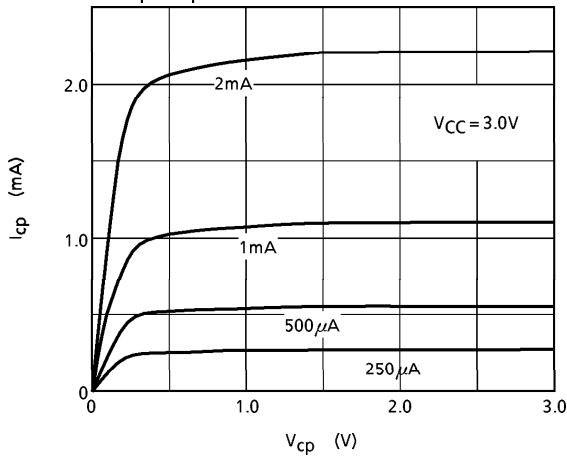

V_{cp} - I_{cp} CHARACTERISTICS PLL2 Nch

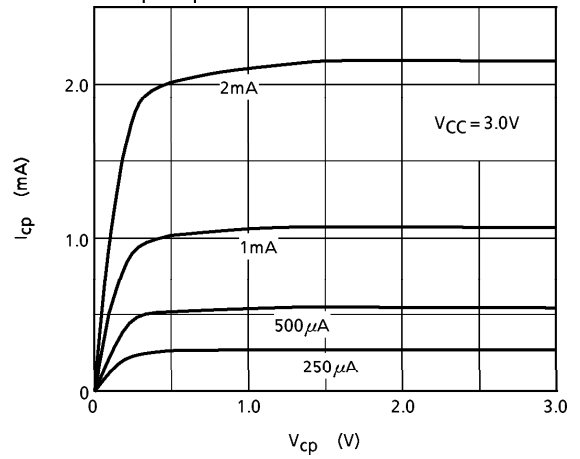

V_{cp} - I_{cp} CHARACTERISTICS PLL1 Pch

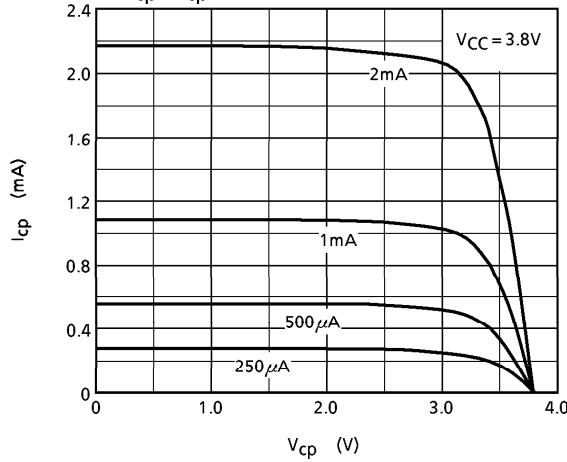

V_{cp} - I_{cp} CHARACTERISTICS PLL2 Pch

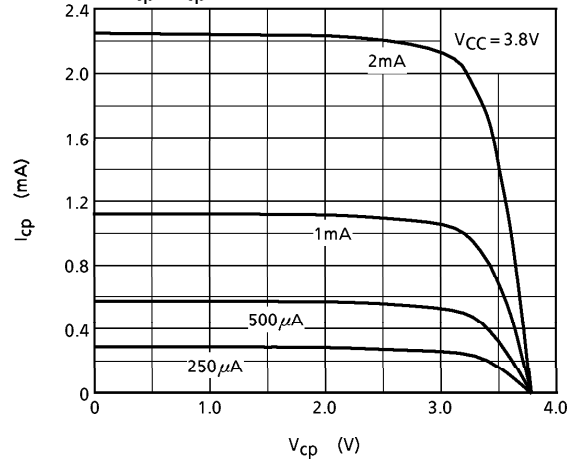

V_{CP} - I_{CP} CHARACTERISTICS PLL1 Nch

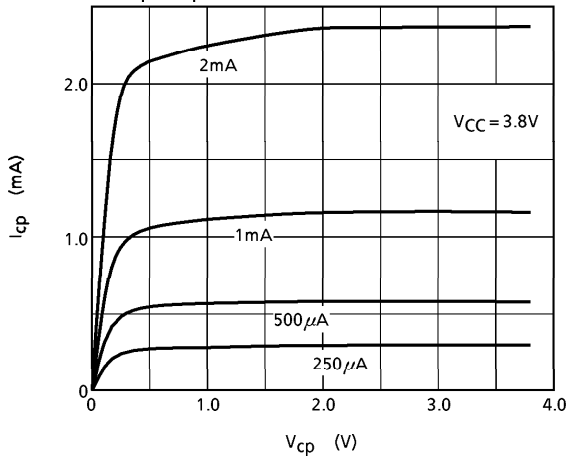

V_{CP} - I_{CP} CHARACTERISTICS PLL2 Nch

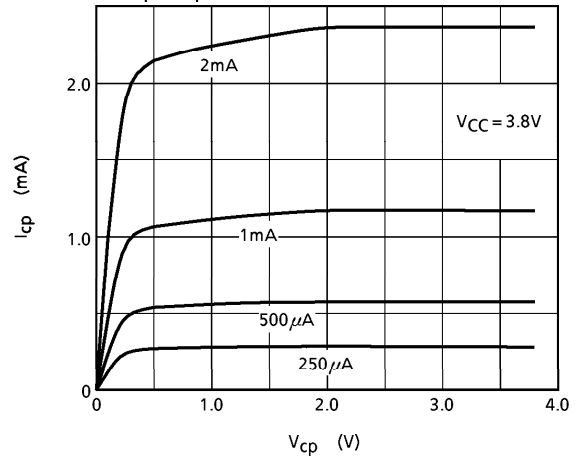

INPUT SENSITIVITY CHARACTERISTICS V_{CC} = 2.2V

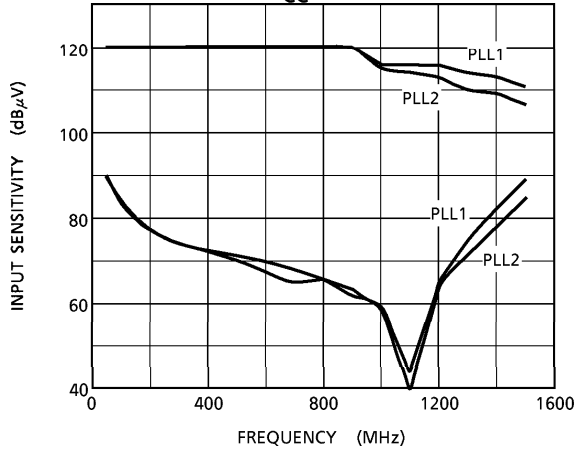

INPUT SENSITIVITY CHARACTERISTICS V_{CC} = 3.0V

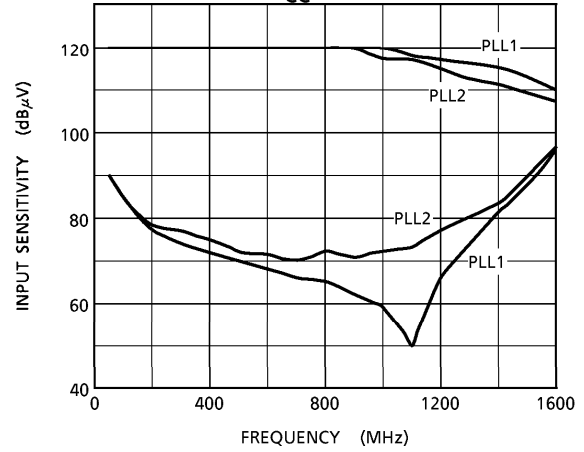

INPUT SENSITIVITY CHARACTERISTICS V_{CC} = 3.8V

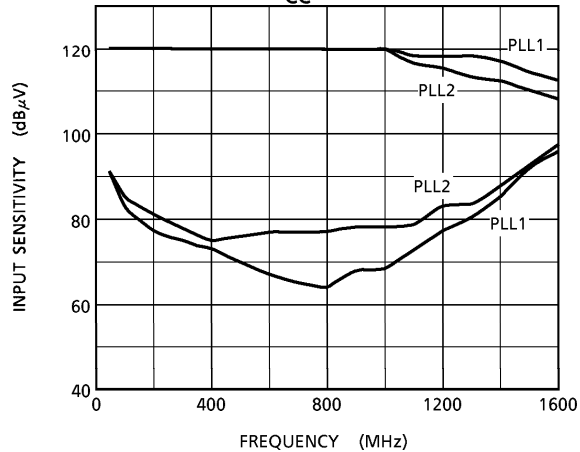

Type marked on product

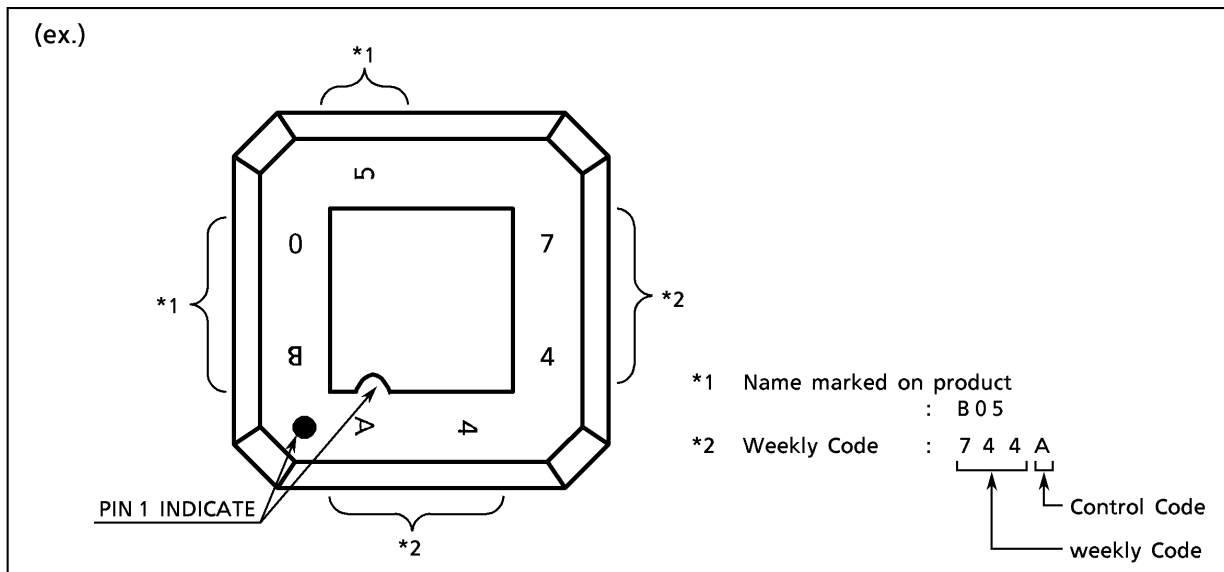

Usage Precautions for Quad Outline Nonlead (QON)

A drawing is the conceptual figure of QON and is not an exact reduced scale drawing. The form of the island area and the lead count is not exact.

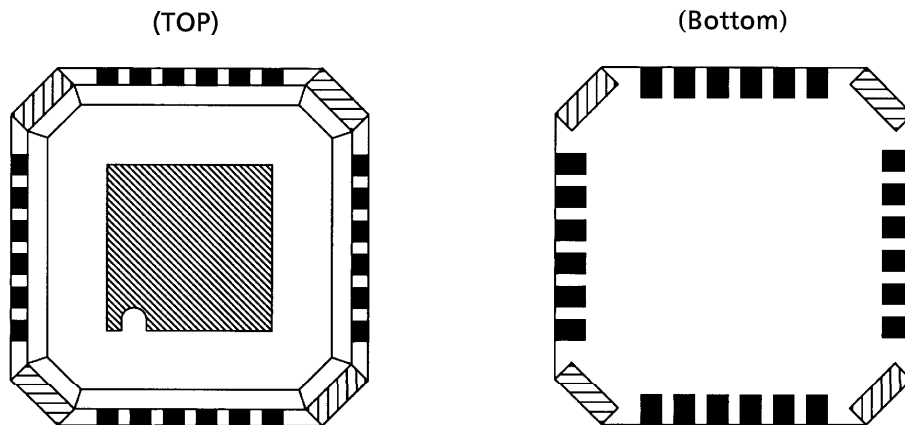

Before using QON, note the following items.

Notes

- (1) Do not solder on the island areas (shaded in bottom view) in the four corners of the package for the purpose of strengthening mechanically.
- (2) Electrically insulate externally (*1) the areas exposed on the surface of the package (shaded in top view) and the island areas in the four corners of the package (shaded in both top and bottom view)
- (3) When mounting or solder-mounting be careful not to apply static electricity or electrical overstress to the IC (protect the device from electrical leakage or charging).
- (4) When using the IC in a set, design the set so that the structure does not allow any voltage to be directly applied to the island areas.

*1 : Make sure that on the substrate layout, soldering for through holes does not touch the island areas (shaded in bottom view).

PACKAGE DIMENSIONS

QON16-P-0404-0.65

Unit : mm

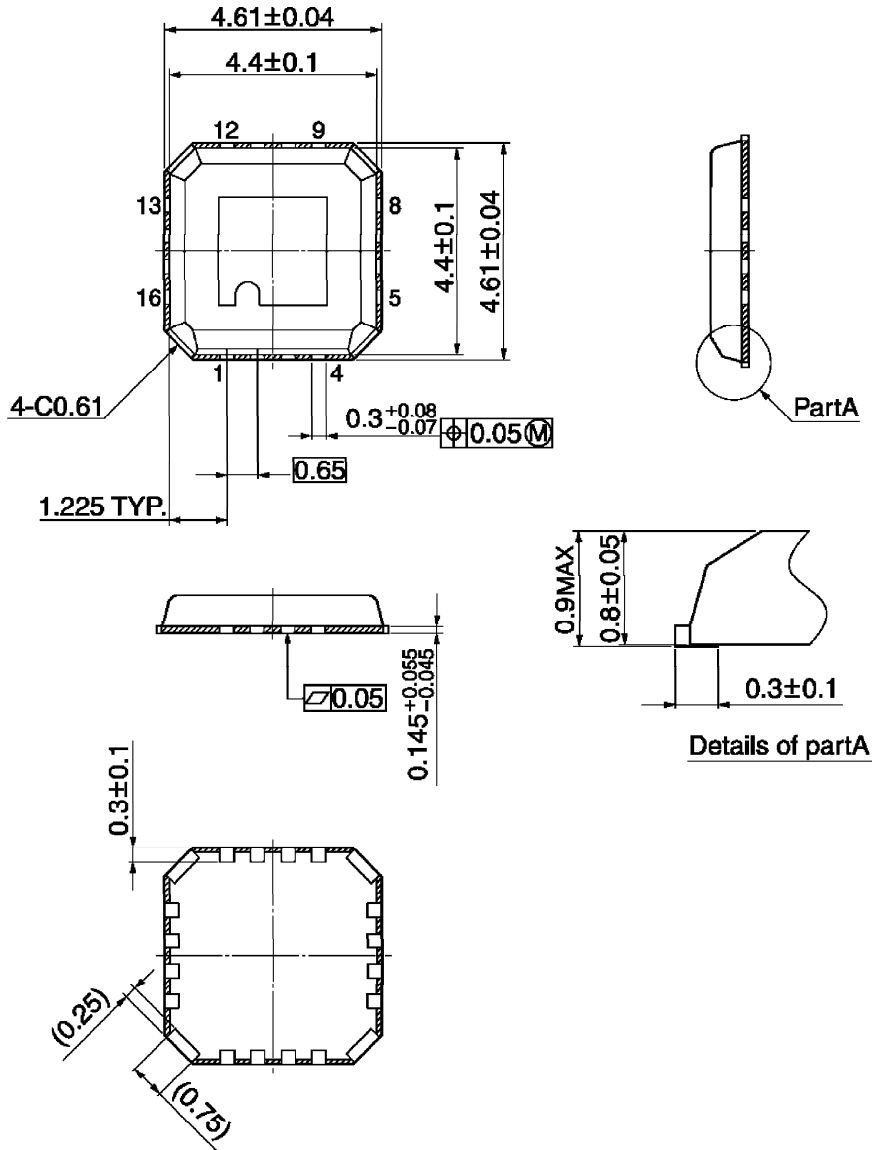

Note 1) The solder plating portion in four corners of the package shall not be treated as an external terminal.

Note 2) Don't carry out soldering to four corners of the package.

Note 3)  area : Resin surface

Weight : 0.04 g (Typ.)

RESTRICTIONS ON PRODUCT USE

000707EDA

- TOSHIBA is continually working to improve the quality and reliability of its products. Nevertheless, semiconductor devices in general can malfunction or fail due to their inherent electrical sensitivity and vulnerability to physical stress. It is the responsibility of the buyer, when utilizing TOSHIBA products, to comply with the standards of safety in making a safe design for the entire system, and to avoid situations in which a malfunction or failure of such TOSHIBA products could cause loss of human life, bodily injury or damage to property. In developing your designs, please ensure that TOSHIBA products are used within specified operating ranges as set forth in the most recent TOSHIBA products specifications. Also, please keep in mind the precautions and conditions set forth in the "Handling Guide for Semiconductor Devices," or "TOSHIBA Semiconductor Reliability Handbook" etc..
- The TOSHIBA products listed in this document are intended for usage in general electronics applications (computer, personal equipment, office equipment, measuring equipment, industrial robotics, domestic appliances, etc.). These TOSHIBA products are neither intended nor warranted for usage in equipment that requires extraordinarily high quality and/or reliability or a malfunction or failure of which may cause loss of human life or bodily injury ("Unintended Usage"). Unintended Usage include atomic energy control instruments, airplane or spaceship instruments, transportation instruments, traffic signal instruments, combustion control instruments, medical instruments, all types of safety devices, etc.. Unintended Usage of TOSHIBA products listed in this document shall be made at the customer's own risk.
- The products described in this document are subject to the foreign exchange and foreign trade laws.
- The products described in this document contain components made in the United States and subject to export control of the U.S. authorities. Diversion contrary to the U.S. law is prohibited.
- The information contained herein is presented only as a guide for the applications of our products. No responsibility is assumed by TOSHIBA CORPORATION for any infringements of intellectual property or other rights of the third parties which may result from its use. No license is granted by implication or otherwise under any intellectual property or other rights of TOSHIBA CORPORATION or others.
- The information contained herein is subject to change without notice.