

Multi-Output Controller with Integrated MOSFET Drivers for AMD SVI Capable Mobile CPUs

ISL6265C

The ISL6265C is a multi-output controller with embedded gate drivers. A single-phase controller powers the Northbridge (VDDNB) portion of the CPU. The two remaining controller channels can be configured for two-phase or individual single-phase outputs. For uniplane CPU applications, the ISL6265C is configured as a two-phase buck converter. This allows the controller to interleave channels to effectively double the output voltage ripple frequency, and thereby reduce output voltage ripple amplitude with fewer components, lower component cost, reduced power dissipation, and smaller area. For dual-plane processors, the ISL6265C can be configured as independent single-phase controllers powering VDD0 and VDD1.

The heart of the ISL6265C is the patented R³ Technology™, Intersil's Robust Ripple Regulator modulator. Compared with the traditional buck regulator, the R³ Technology™ has a faster transient response. This is due to the R³ modulator commanding variable switching frequency during a load transient.

The Serial VID Interface (SVI) allows dynamic adjustment of the Core and Northbridge output voltages independently and in combination from 0.500V to 1.55V. Core and Northbridge output voltages achieve a 0.5% system accuracy over-temperature.

A unity-gain differential amplifier is provided for remote CPU die sensing. This allows the voltage on the CPU die to be accurately regulated per AMD mobile CPU specifications. Core output current sensing is realized using lossless inductor DCR sensing. All outputs feature overcurrent, overvoltage and undervoltage protection.

Features

- Core Configuration Flexibility
 - Dual Plane, Single-Phase Controllers
 - Uniplane, Two-Phase Controller
- Precision Voltage Regulators
 - 0.5% System Accuracy Over-temperature
- Voltage Positioning with Adjustable Load Line and Offset
- Internal Gate Drivers with 2A Driving Capability
- Differential Remote CPU Die Voltage Sensing
- Core Differential Current Sensing: DCR or Resistor
- Northbridge Lossless $r_{DS(ON)}$ Current Sensing
- Serial VID Interface
 - Two Wire Clock and Data Bus
 - Supports High-Speed I²C
 - 0.500V to 1.55V in 12.5mV Steps
 - Supports PSI_L Power-Saving Mode
- Core Outputs Feature Phase Shedding with PSI_L
- Adjustable Output-Voltage Offset
- Digital Soft-Start of all Outputs
- User Programmable Switching Frequency
- Static and Dynamic Current Sharing (Uniplane Core)
- Overvoltage, Undervoltage, and Overcurrent Protection
- Pb-Free (RoHS compliant)

Applications* (see page 26)

- AMD Griffin Platform CPU
- Notebook Core/GPU Voltage Regulators

Related Literature* (see page 26)

- See [FN6884](#) for "Multi-Output Controller with Integrated MOSFET Drivers for AMD SVI Capable Mobile CPUs"

Simplified System Diagram

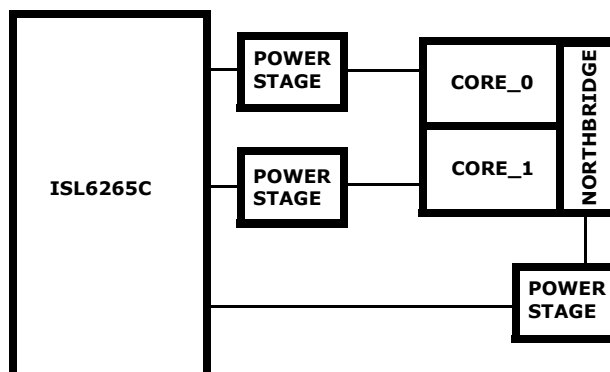

Functional Block Diagram

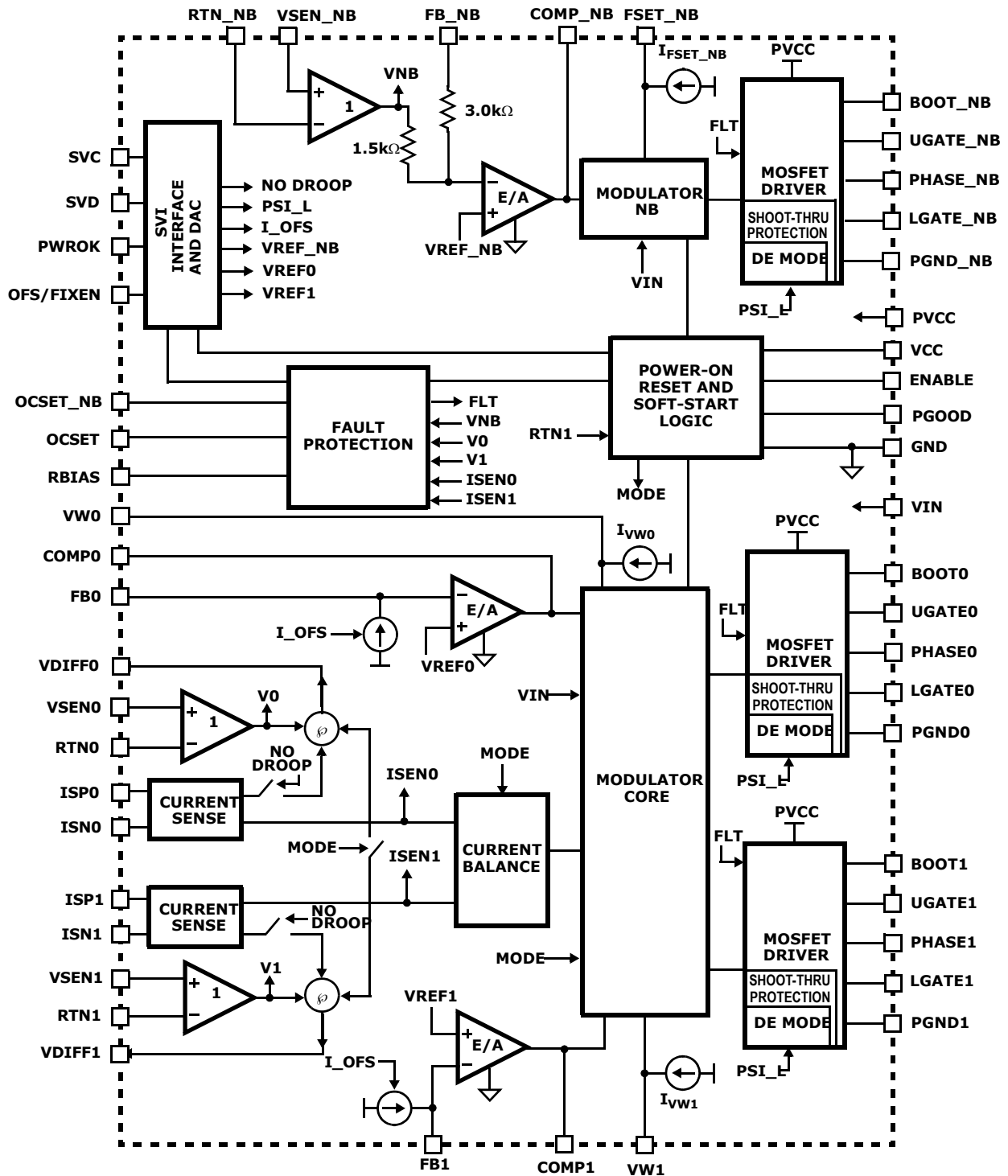

FIGURE 1. SIMPLIFIED FUNCTIONAL BLOCK DIAGRAM OF ISL6265C

ISL6265C

Ordering Information

PART NUMBER (Note)	PART MARKING	TEMP RANGE (°C)	PACKAGE (Pb-Free)	PKG. DWG. #
ISL6265CHRTZ	6265C HRTZ	-10 to +100	48 Ld 6x6 TQFN	L48.6x6
ISL6265CHRTZ-T	6265C HRTZ	-10 to +100	48 Ld 6x6 TQFN Tape and Reel	L48.6x6

1. Please refer to [TB347](#) for details on reel specifications.
2. These Intersil Pb-free plastic packaged products employ special Pb-free material sets, molding compounds/die attach materials, and 100% matte tin plate plus anneal (e3 termination finish, which is RoHS compliant and compatible with both SnPb and Pb-free soldering operations). Intersil Pb-free products are MSL classified at Pb-free peak reflow temperatures that meet or exceed the Pb-free requirements of IPC/JEDEC J STD-020.
3. For Moisture Sensitivity Level (MSL), please see device information page for [ISL6265C](#). For more information on MSL please see techbrief [TB363](#).

Pin Configuration

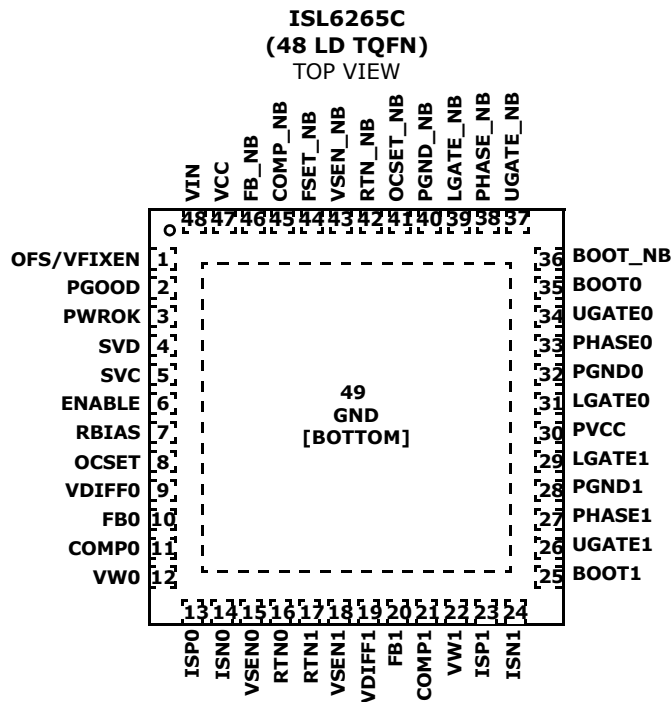

Pin Descriptions

PIN(s)	SYMBOL(s)	DESCRIPTION
1	OFS/VFIXEN	A resistor from this pin to GND programs a DC current source, which generates a positive offset voltage across the resistor between FB and VDIFF pins. In this case, the OFS pin voltage is +1.2V and VFIX mode is not enabled. If OFS is pulled up to +3.3V, VFIX mode is enabled, the DAC decodes the SVC and SVD inputs to determine the programmed voltage, and the OFS function is disabled. If OFS is pulled up to +5V, the OFS function and VFIX mode are disabled.
2	PGOOD	Controller power-good open-drain output. This pin is typically pulled up externally by a 2.0kΩ resistor to +3.3V. During normal operation, this pin indicates whether all output voltages are within specified overvoltage and undervoltage limits and no overcurrent condition is present. If any output voltage exceeds these limits or a reset event occurs, the pin is pulled low. This pin is always low prior to the end of soft-start.
3	PWROK	System power good input. When this pin is high, the SVI interface is active and I ² C protocol is running. While this pin is low, the SVC, SVD, and VFIXEN input states determine the pre-PWROK metal VID or VFIX mode voltage. This pin must be low prior to the ISL6265C PGOOD output going high per the AMD SVI Controller Guidelines.
4	SVD	This pin is the serial VID data bidirectional signal to and from the master device on the AMD processor.
5	SVC	This pin is the serial VID clock input from the AMD processor.
6	ENABLE	Digital input enable. A high level logic signal on this pin enables the ISL6265C.
7	RBIAS	A 117kΩ resistor from RBIAS to GND sets internal reference currents. The addition of capacitance to this pin must be avoided and can create instabilities in operation.
8	OCSET	CORE_0 and CORE_1 common overcurrent protection selection input. The voltage on this pin sets the (ISP _x - ISN _x) voltage limit for OC trip.
9, 19	VDIFF0, VDIFF1	Output of the CORE_0 and CORE_1 differential amplifiers.
10, 20	FB0, FB1	These pins are the output voltage feedback to the inverting input of the CORE_0 and CORE_1 error amplifiers.
11, 21	COMP0, COMP1	The output of the CORE_0 and CORE_1 controller error amplifiers respectively. FB _x , VDIFF _x , and COMP _x pins are tied together through external R-C networks to compensate the regulator
12, 22	VW0, VW1	A resistor from this pin to corresponding COMP _x pin programs the switching frequency (for example, 6.81k ~ 300kHz).
13, 14, 23, 24	ISPO, ISNO, ISP1, ISN1	These pins are used for differentially sensing the corresponding channel output current. The sensed current is used for channel balancing, protection, and core load line regulation. Connect ISNO and ISN1 to the node between the RC sense elements surrounding the inductor of their respective channel. Tie the ISPO and ISP1 pins to the V _{CORE} side of their corresponding channel's sense capacitor. These pins can also be used for discrete resistor sensing.
15, 16	VSEN0, RTN0	Inputs to the CORE_0 VR controller precision differential remote sense amplifier. Connect to the sense pins of the VDD0_FB[H,L] portion of the processor.
18, 17	VSEN1, RTN1	Inputs to the CORE_1 VR controller precision differential remote sense amplifier. Connect to the sense pins of the VDD1_FB[H,L] portion of the processor. The RTN1 pin is also used for detection of the VDD_PLANE_STRAP signal prior to enable.
30	PVCC	The power supply pin for the internal MOSFET gate drivers of the ISL6265C. Connect this pin to a +5V power supply. Decouple this pin with a quality 1.0μF ceramic capacitor.
31, 29	LGATE0, LGATE1	Connect these pins to the corresponding lower MOSFET gate(s).
32, 28	PGND0, PGND1	The return path of the lower gate driver for CORE_0 and CORE_1 respectively. Connect these pins to the corresponding sources of the lower MOSFETs.
33, 27	PHASE0, PHASE1	Switch node of the CORE_0 and CORE_1 controllers. Connect these pins to the sources of the corresponding upper MOSFET(s). These pins are the return path for the upper MOSFET drives.

ISL6265C

Pin Descriptions (Continued)

PIN(s)	SYMBOL(s)	DESCRIPTION
34, 26	UGATE0, UGATE1	Connect these pins to the corresponding upper MOSFET gate(s). These pins control the upper MOSFET gate(s) and are monitored for shoot-through prevention.
35, 25	BOOT0, BOOT1	These pins provide the bias voltage for the corresponding upper MOSFET drives. Connect these pins to appropriately chosen external bootstrap capacitors. Internal bootstrap diodes connected to the PVCC pin provide the necessary bootstrap charge.
36	BOOT_NB	This pin is the upper gate drive supply voltage for the Northbridge controller. Connect an appropriately sized ceramic bootstrap capacitor between the BOOT_NB and PHASE_NB pins. An internal bootstrap diode connected to the PVCC pin provides the necessary bootstrap charge.
37	UGATE_NB	Upper MOSFET gate signal from Northbridge controller.
38	PHASE_NB	Switch node of the Northbridge controller. This pin should connect to the source of the Northbridge channel upper MOSFET(s).
39	LGATE_NB	Lower MOSFET gate signal from Northbridge controller.
40	PGND_NB	The return path of the Northbridge controller lower gate driver. Connect this pin to the source of the lower MOSFET(s).
41	OCSET_NB	Overcurrent protection selection input for the Northbridge controller. A resistor from this pin to PHASE_NB sets the OC trip point.
43, 42	VSEN_NB, RTN_NB	Remote Northbridge voltage sense input and return. Connect isolated traces from these pins to the Northbridge sense points of the processor.
44	FSET_NB	A resistor from this pin to GND programs the switching frequency of the Northbridge controller (for example, 22.1k ~ 260kHz).
45	COMP_NB	This pin is the output of the Northbridge controller error amplifier.
46	FB_NB	This pin is the output voltage feedback to the inverting input of the Northbridge controller error amplifier.
47	VCC	The bias supply for the IC's control circuitry. Connect this pin to a +5V supply and decouple using a quality 0.1µF ceramic capacitor.
48	VIN	Battery supply voltage. It is used for input voltage feed-forward to improve the input line transient performance.
-	GND	The bias and reference ground for the IC. The GND connection for the ISL6265C is through the thermal pad on the bottom of the package.

Simplified Application Circuit for Dual Plane and Northbridge Support

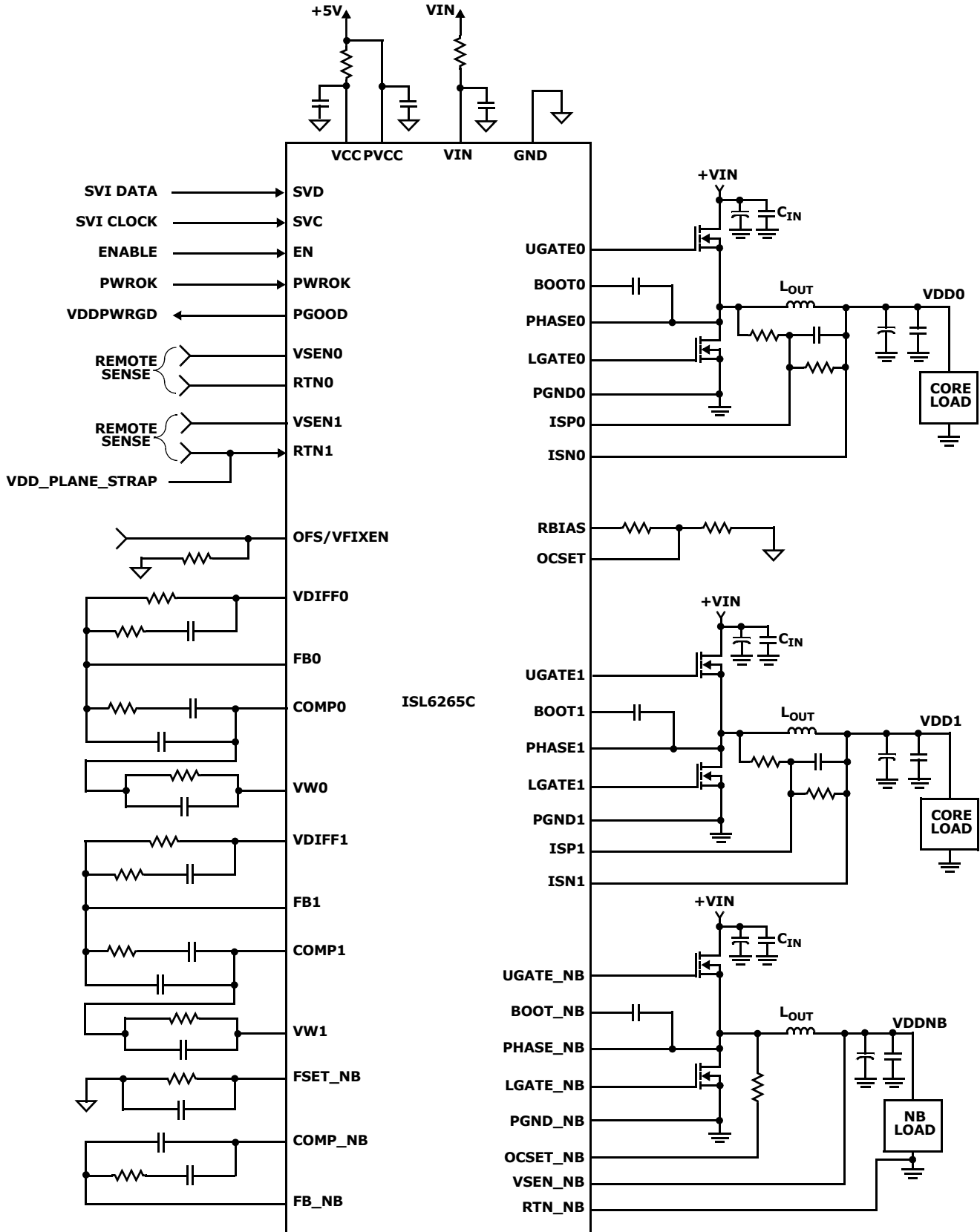

FIGURE 2. ISL6265C BASED DUAL-PLANE AND NORTHBRIDGE CONVERTERS WITH INDUCTOR DCR CURRENT SENSING

Simplified Application Circuit for Uniplane Core and Northbridge Support

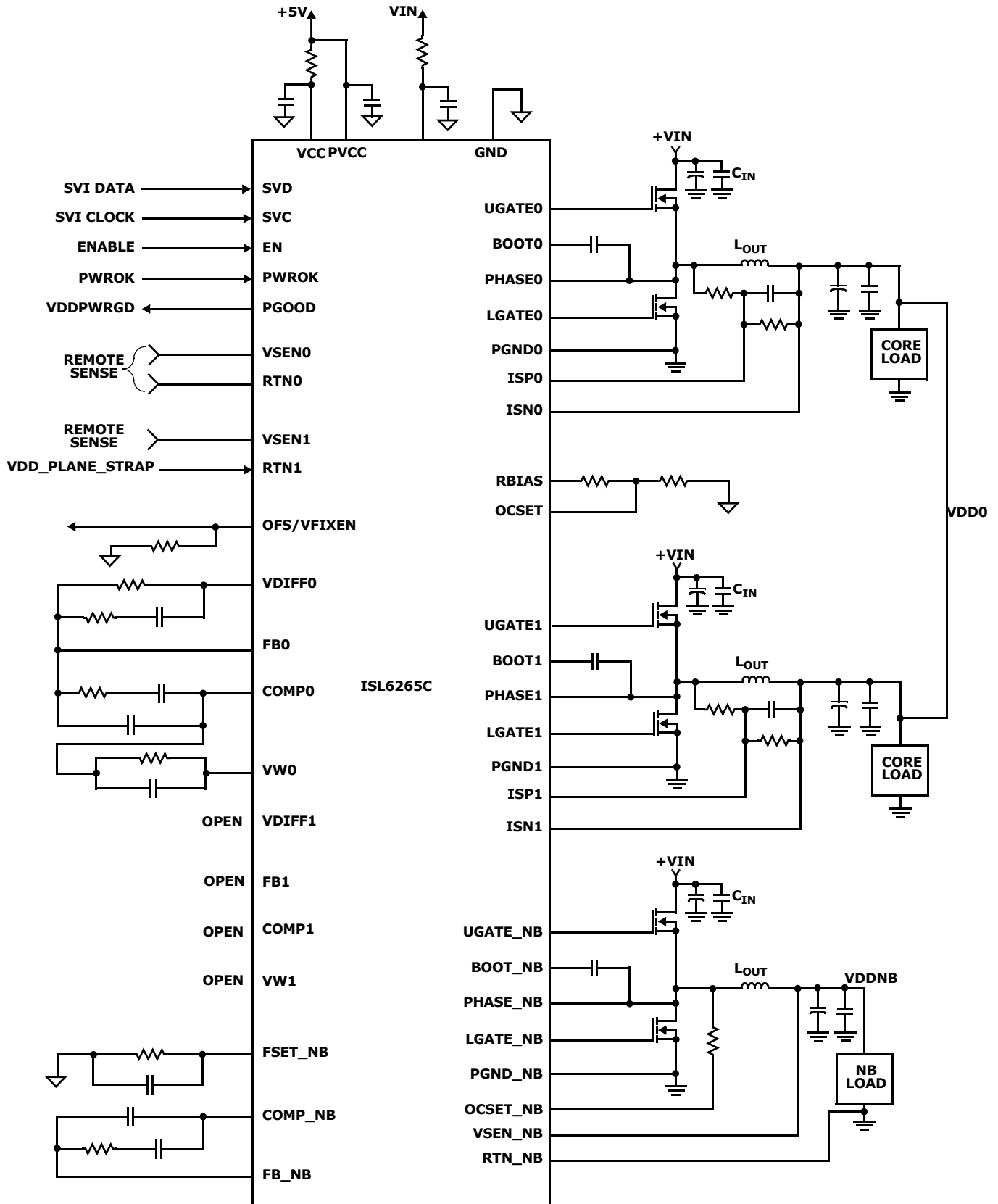

FIGURE 3. ISL6265C BASED UNIPLANE AND NORTHBRIDGE CONVERTERS WITH INDUCTOR DCR CURRENT SENSING

Simplified Application Circuit for Dual Layout

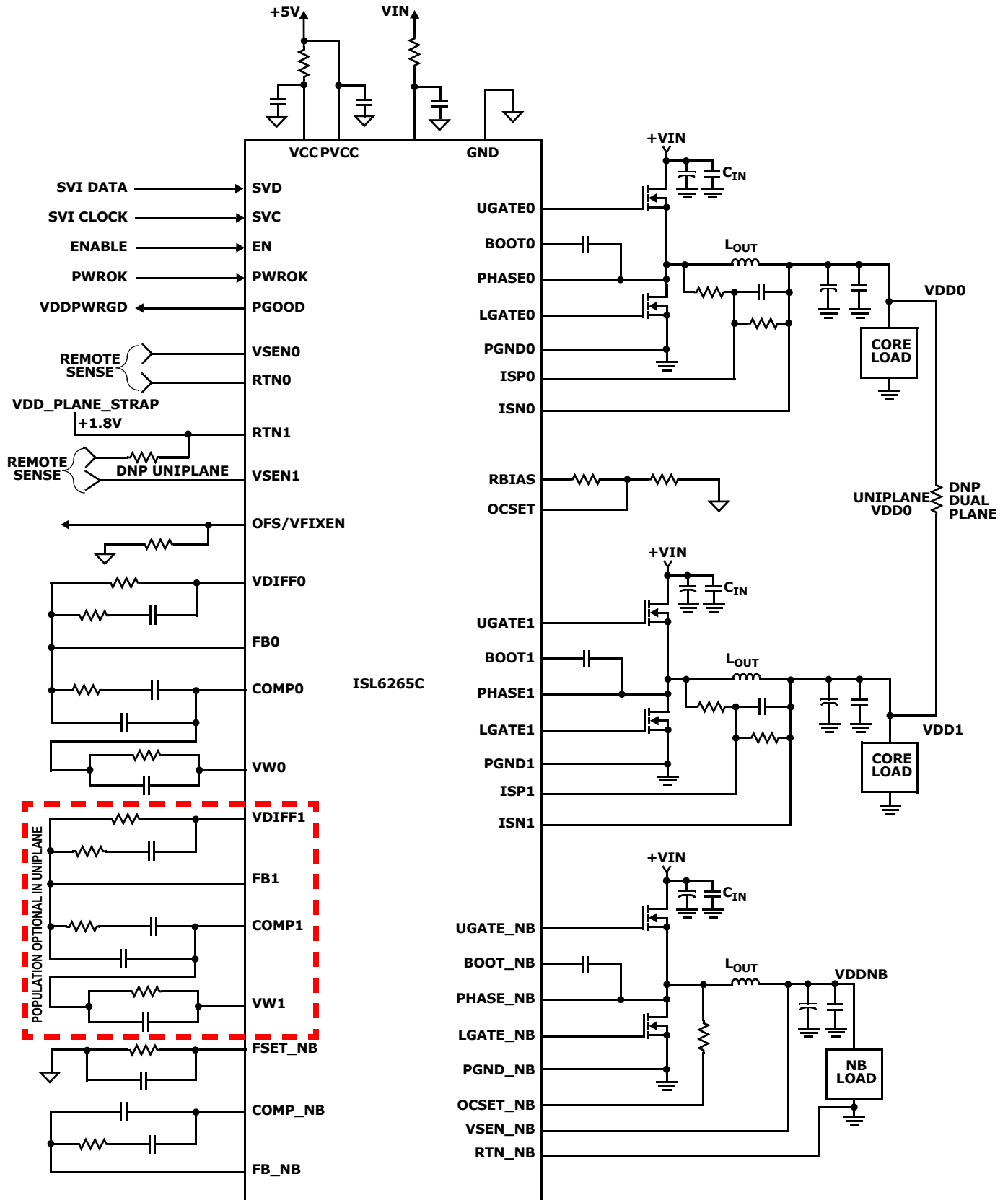

FIGURE 4. ISL6265C BASED UNIPLANE OR DUAL PLANE CORE CONVERTER WITH INDUCTOR DCR CURRENT SENSING

Table of Contents

Simplified System Diagram	1	Operation	18
Functional Block Diagram	2	Switching Frequency	18
Ordering Information	3	Current Sense	18
Pin Configuration	3	Selecting RBIAS For Core Outputs.....	19
Pin Descriptions	4	Offset Resistor Selection.....	19
Simplified Application Circuit for Dual Plane and Northbridge Support	6	Internal Driver Operation	20
Simplified Application Circuit for Uniplane Core and Northbridge Support	7	MOSFET Gate-Drive Outputs	20
Simplified Application Circuit for Dual Layout ...	8	Diode Emulation	20
Absolute Maximum Ratings	10	Power-Savings Mode	20
Thermal Information	10	Northbridge And Dual Plane Core	20
Recommended Operating Conditions	10	Uniplane Core	20
Electrical Specifications	10	Fault Monitoring and Protection	21
ISL6265C Gate Driver Timing Diagram	13	Power-Good Signal	21
Theory of Operation	13	Overcurrent Protection	21
Modulator	13	Overvoltage Protection	22
Initialization	14	Undervoltage Protection	22
Power-On Reset	14	General Application Design Guide	22
Core Configuration	14	Selecting the LC Output Filter.....	22
Mode Selection	14	Selection of the Input Capacitor.....	23
Serial VID Interface	14	MOSFET Selection and Considerations	23
Pre-PWROK Metal VID.....	14	Selecting The Bootstrap Capacitor.....	24
VFIX MODE	15	PCB Layout Considerations	24
SVI MODE.....	16	Power and Signal Layers Placement on the PCB .	24
VID-On-the-Fly Transition	16	Component Placement	24
SVI WIRE Protocol.....	16	Signal Ground and Power Ground	25
SVI Bus Protocol	17	Routing and Connection Details	25
		Copper Size for the Phase Node.....	25
		Revision History	26
		Products	26
		Package Outline Drawing	27

ISL6265C

Absolute Maximum Ratings

Supply Voltage, VCC, PVCC	-0.3 - +7V
Battery Voltage, VIN	+28V
Boot Voltage (BOOT)	-0.3V to +33V
Boot to Phase Voltage (BOOT-PHASE)	-0.3V to +7V(DC)
	-0.3V to +9V (<10ns)
Phase Voltage (PHASE)	-7V (<20ns Pulse Width, 10μJ)
UGATE Voltage (UGATE)	PHASE -0.3V (DC) to BOOT
LGATE Voltage (LGATE)	-0.3V (DC) to VCC + 0.3V
ALL Other Pins	-0.3V to (VCC + 0.3V)
Open Drain Outputs, PGOOD	-0.3 - +7V

Thermal Information

Thermal Resistance (Typical, Notes 4, 5) θ_{JA} (°C/W) θ_{JC} (°C/W)		
TQFN Package	28	3.5
Maximum Junction Temperature	+150°C	
Maximum Storage Temperature Range	-65°C to +150°C	
Pb-Free Reflow Profile	see link below	
	http://www.intersil.com/pbfree/Pb-FreeReflow.asp	

Recommended Operating Conditions

Supply Voltage, VCC, PVCC	+5V ±5%
Battery Voltage, VIN	+6V to 24V
Ambient Temperature	-10°C to +100°C
Junction Temperature	-10°C to +125°C

CAUTION: Do not operate at or near the maximum ratings listed for extended periods of time. Exposure to such conditions may adversely impact product reliability and result in failures not covered by warranty.

NOTES:

- θ_{JA} is measured in free air with the component mounted on a high effective thermal conductivity test board with "direct attach" features. See Tech Brief TB379.
- For θ_{JC} , the "case temp" location is the center of the exposed metal pad on the package underside.

Electrical Specifications VCC = PVCC = 5V, VIN = 12V, TA = -10°C to +100°C, Unless Otherwise Specified. **Boldface limits apply over the operating temperature range, -10°C to +100°C.**

PARAMETER	SYMBOL	TEST CONDITIONS	MIN (Note 6)	TYP	MAX (Note 6)	UNITS
INPUT POWER SUPPLY						
+5V Supply Current	IVCC	EN = 3.3V	-	7.8	10	mA
		EN = 0V	-	-	1	μA
POR (Power-On Reset) Threshold	VCC PORr	VCC Rising	-	4.35	4.5	V
	VCC PORf	VCC Falling	3.9	4.1	-	V
Battery Supply Current (VIN)	IVIN	EN = 0V, VIN = 24V	-	-	1	μA
SYSTEM AND REFERENCES						
System Accuracy (Vcore0, Vcore1, Vcore_NB)	%Error (VCORE)	No load, closed loop, active mode VID = 0.75V to 1.55V	-0.5	-	0.5	%
		VID = 0.50V to 0.7375V	-5	-	+5	mV
RBIAS Voltage	RRBIAS	RRBIAS = 117kΩ	1.15	1.17	1.19	V
Maximum Output Voltage	VCOREx (max)	SVID = [000_0000b]	-	1.55	-	V
Minimum Output Voltage	VCOREx (min)	SVID = [101_0100b]	-	0.500	-	V
CHANNEL FREQUENCY						
Nominal CORE Switching Frequency	fSW_core0	VIN = 15.5V, VDAC = 1.55V, VFB0 = 1.60V, force Vcomp_0 = 2V, RVW = 6.81kΩ, 2-Phase Operation	285	300	315	kHz
Nominal NB Switching Frequency	fSW_core_NB	RFBSET_NB = 22.1kΩ, CFSET_NB = 1nF, VDAC = 0.5V, Vsen_nb = 0.51V	285	300	315	kHz
Core Frequency Adjustment Range			200	-	500	kHz
NB Frequency Adjustment Range			200	-	500	kHz
AMPLIFIERS						
Error Amp DC Gain (Note 7)	AV0		-	90	-	dB

ISL6265C

Electrical Specifications $V_{CC} = PV_{CC} = 5V$, $V_{IN} = 12V$, $T_A = -10^{\circ}C$ to $+100^{\circ}C$, Unless Otherwise Specified. **Boldface limits apply over the operating temperature range, $-10^{\circ}C$ to $+100^{\circ}C$.** (Continued)

PARAMETER	SYMBOL	TEST CONDITIONS	MIN (Note 6)	TYP	MAX (Note 6)	UNITS
Error Amp Gain-Bandwidth Product (Note 7)	GBW	$C_L = 20pF$	-	18	-	MHz
Error Amp Slew Rate (Note 7)	SR	$C_L = 20pF$	-	5.0	-	V/ μs
CORE CURRENT SENSE						
Current Imbalance Threshold			-	4	-	mV
Input Bias Current			-	20	-	nA
RTN1 Threshold			-	0.8	-	V
SOFT START/VID-ON-THE-FLY						
Soft-Start Voltage Transition	V_{SS}		1.25	1.875	2.50	mV/ μs
VID on the Fly Transition			5	7.5	10	mV/ μs
GATE DRIVER DRIVING CAPABILITY [CORE AND NB]						
UGATE Source Resistance (Note 8)	$R_{SRC(UGATE)}$	500mA Source Current	-	1	1.5	Ω
UGATE Source Current (Note 8)	$I_{SRC(UGATE)}$	$V_{UGATE_PHASE} = 2.5V$	-	2	-	A
UGATE Sink Resistance (Note 8)	$R_{SNK(UGATE)}$	500mA Sink Current	-	1	1.5	Ω
UGATE Sink Current (Note 8)	$I_{SNK(UGATE)}$	$V_{UGATE_PHASE} = 2.5V$	-	2	-	A
LGATE Source Resistance (Note 8)	$R_{SRC(LGATE)}$	500mA Source Current	-	1	1.5	Ω
LGATE Source Current (Note 8)	$I_{SRC(LGATE)}$	$V_{LGATE} = 2.5V$	-	2	-	A
LGATE Sink Resistance (Note 8)	$R_{SNK(LGATE)}$	500mA Sink Current	-	0.5	0.9	Ω
LGATE Sink Current (Note 8)	$I_{SNK(LGATE)}$	$V_{LGATE} = 2.5V$	-	4	-	A
UGATE to PHASE Resistance	$R_p(UGATE)$		-	1	-	k Ω
GATE DRIVER SWITCHING TIMING (Refer to "ISL6265C Gate Driver Timing Diagram" on page 13)						
UGATE Rise Time (Note 7)	t_{RU}	$PV_{CC} = 5V$, 3nF Load	-	8.0	-	ns
LGATE Rise Time (Note 7)	t_{RL}	$PV_{CC} = 5V$, 3nF Load	-	8.0	-	ns
UGATE Fall Time (Note 7)	t_{FU}	$PV_{CC} = 5V$, 3nF Load	-	8.0	-	ns
LGATE Fall Time (Note 7)	t_{FL}	$PV_{CC} = 5V$, 3nF Load	-	4.0	-	ns
UGATE Turn-on Propagation Delay	t_{PDHU}	$PV_{CC} = 5V$, Outputs Unloaded	-	36	-	ns
LGATE Turn-on Propagation Delay	t_{PDHL}	$PV_{CC} = 5V$, Outputs Unloaded	-	20	-	ns
BOOTSTRAP DIODE						
Forward Voltage		$V_{DDP} = 5V$, Forward Bias Current = 2mA	0.43	0.58	0.67	V
Leakage		$V_R = 16V$	-	-	5	μA
POWER-GOOD AND PROTECTION MONITOR						
PGOOD Low Voltage	V_{OL}	$I_{PGOOD} = 4mA$	-	0.2	0.5	V
PGOOD Leakage Current	I_{OH}	$P_{GOOD} = 5V$	-1	-	1	μA
PGOOD High After Soft-Start		Enable to PGOOD High, $V_{COREX} = 1.1V$	570	700	1010	μs
PGOOD Low After Fault		Fault to PGOOD Low	160	208	250	μs
Undervoltage Threshold	U_{VH}	V_{COREX} falls below set-point for 208 μs	240	295	350	mV

ISL6265C

Electrical Specifications VCC = PVCC = 5V, VIN = 12V, TA = -10°C to +100°C, Unless Otherwise Specified. **Boldface limits apply over the operating temperature range, -10°C to +100°C. (Continued)**

PARAMETER	SYMBOL	TEST CONDITIONS	MIN (Note 6)	TYP	MAX (Note 6)	UNITS
Overvoltage Threshold	O _{VHS}	V _O rising above threshold > 0.5μs	1.770	1.800	1.825	V
OVERCURRENT PROTECTION VDD0 AND VDD1						
OCSET Reference Voltage (V _{ISPX} - V _{ISNX})		V _{OCSET} = 180mV; VIN = 15.5V	5	6.0	7	mV
OVERCURRENT PROTECTION VDD_NB						
OCSET_NB OCP Current		RBIAS pin to GND = 117kΩ; Trips after 8 PWM cycles	9.2	10	10.8	μA
OFFSET FUNCTION						
OFS Pin Voltage For Droop Enabling	V _{OFS}	R _{OFS} = 240kΩ (OFS pin to GND)	1.18	1.2	1.22	V
FB Pin Source Current	I _{FB}	I _{OFS} = 10μA	9.0	9.9	10.8	μA
OFS Pin Voltage Threshold for VFIX Mode and No Droop Operation	V _{OFS}		-	1.8	-	V
OFS Pin Voltage Threshold for SVI Mode and No Droop Operation	V _{OFS}		-	4.0	-	V
OFS Bias	I _{OFS}	1.8V < OFS < VCC	-	4.0	-	μA
LOGIC INPUTS						
ENABLE Low Threshold	V _{IL(3.3V)}		-	1.35	0.9	V
ENABLE High Threshold	V _{IH(3.3V)}		2.0	1.6	-	V
ENABLE Leakage Current		Logic input is low	-1	0	-	μA
		Logic input is high at 3.3V	-	0	1	μA
SVI INTERFACE						
PWROK Input Low Threshold			-	0.65	0.8	V
PWROK Input High Threshold			-	0.9	-	V
SVC, SVD Input HIGH (VIH)			1.05	0.87	-	V
SVC, SVD Input LOW (VIL)			-	0.68	0.45	V
Schmitt Trigger Input Hysteresis			-	0.19	-	V
SVD Low Level Output Voltage		3mA Sink Current	-	0.1	0.285	V
SVC, SVD Leakage		EN = 0V, SVC, SVD = 0V	-	< -100	-	nA
		EN = 5V, SVC, SVD = 1.8V	-	< -100	-	nA
DIFF AMP						
Accuracy		VSEN = 0.5V to 1.55V; RTN = 0 ±0.1V	-2	-	2	mV

NOTES:

- Parameters with MIN and/or MAX limits are 100% tested at +25°C, unless otherwise specified. Temperature limits established by characterization and are not production tested
- Limits should be considered typical and are not production tested.
- Limits established by characterization and are not production tested.

ISL6265C Gate Driver Timing Diagram

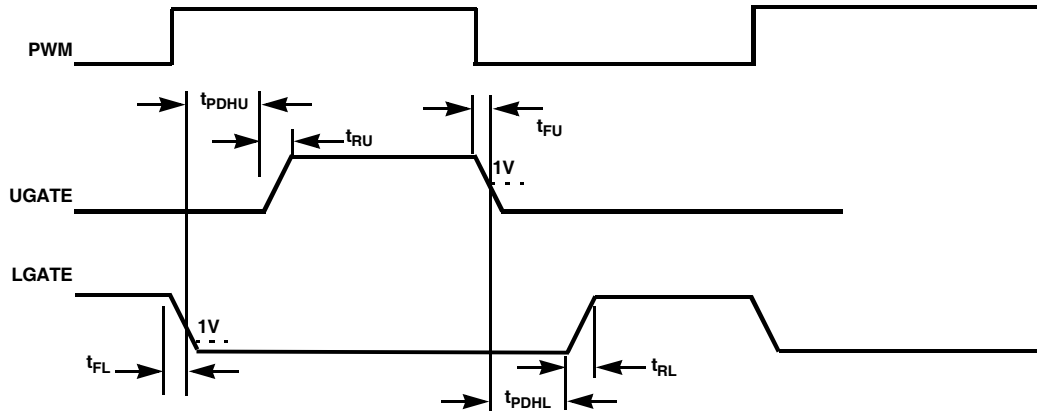

Theory of Operation

The ISL6265C is a flexible multi-output controller supporting Northbridge and single or dual power planes required by Class M AMD Mobile CPUs. In single plane applications, both core voltage regulators operate single-phase. In uniplane core applications, the core voltage regulators are configured to operate as a two-phase regulator. All three regulator outputs include integrated gate drivers for reduced system cost and small board area. The regulators provide optimum steady-state and transient performance for microprocessor applications. System efficiency is enhanced by idling a phase in uniplane configurations at low-current and implementing automatic DCM-mode operation when PSI_L is asserted to logic low.

The heart of the ISL6265C is the R^3 Technology™, Intersil's Robust Ripple Regulator modulator. The R^3 modulator combines the best features of fixed frequency PWM and hysteretic PWM while eliminating many of their shortcomings. The ISL6265C modulator internally synthesizes an analog of the inductor ripple current and uses hysteretic comparators on those signals to establish PWM pulse widths. Operating on these large-amplitude, noise-free synthesized signals allows the ISL6265C to achieve lower output ripple and lower phase jitter than either conventional hysteretic or fixed frequency PWM controllers. Unlike conventional hysteretic converters, the ISL6265C has an error amplifier that allows the controller to maintain a 0.5% voltage regulation accuracy throughout the VID range from 0.75V to 1.55V. Voltage regulation accuracy is slightly wider, $\pm 5\text{mV}$, over the VID range from 0.7375V to 0.5V.

The hysteresis window voltage is relative to the error amplifier output such that load current transients result in increased switching frequency, which gives the R^3 regulator a faster response than conventional fixed frequency PWM controllers. In uniplane configurations, transient load current is inherently shared between active phases due to the use of a common hysteretic window voltage. Individual average phase currents are monitored and controlled to equally share current among the active phases.

Modulator

The ISL6265C modulator features Intersil's R^3 technology, a hybrid of fixed frequency PWM control and variable frequency hysteretic control (see Figure 5). Intersil's R^3 technology can simultaneously affect the PWM switching frequency and PWM duty cycle in response to input voltage and output load transients. The R^3 modulator synthesizes an AC signal V_R , which is an analog representation of the output inductor ripple current. The duty-cycle of V_R is the result of charge and discharge current through a ripple capacitor C_R . The current through C_R is provided by a transconductance amplifier g_m that measures the V_{IN} and V_{OUT} voltages. The positive slope of V_R can be written as determined by Equation 1:

$$V_{RPOS} = (g_m) \cdot (V_{IN} - V_{OUT}) \quad (\text{EQ. 1})$$

The negative slope of V_R can be written as determined by Equation 2:

$$V_{RNEG} = g_m \cdot V_{OUT} \quad (\text{EQ. 2})$$

Where g_m is the gain of the transconductance amplifier. A window voltage V_W is referenced with respect to the error amplifier output voltage V_{COMP} , creating an envelope into which the ripple voltage V_R is compared. The amplitude of V_W is set by a resistor connected across the FSET and GND pins. The V_R , V_{COMP} , and V_W signals feed into a window comparator in which V_{COMP} is the lower threshold voltage and V_W is the higher threshold voltage. Figure 6 shows PWM pulses being generated as V_R traverses the V_W and V_{COMP} thresholds. The PWM switching frequency is proportional to the slew rates of the positive and negative slopes of V_R ; it is inversely proportional to the voltage between V_W and V_{COMP} .

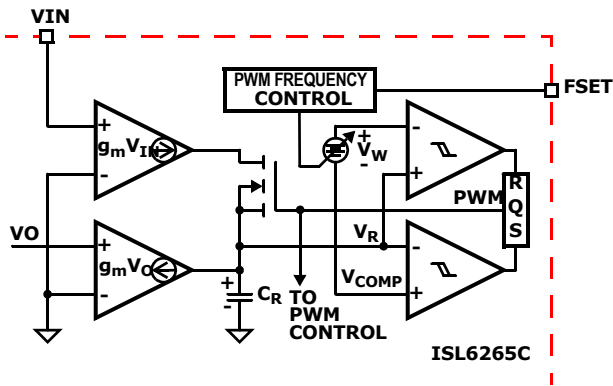

FIGURE 5. MODULATOR CIRCUITRY

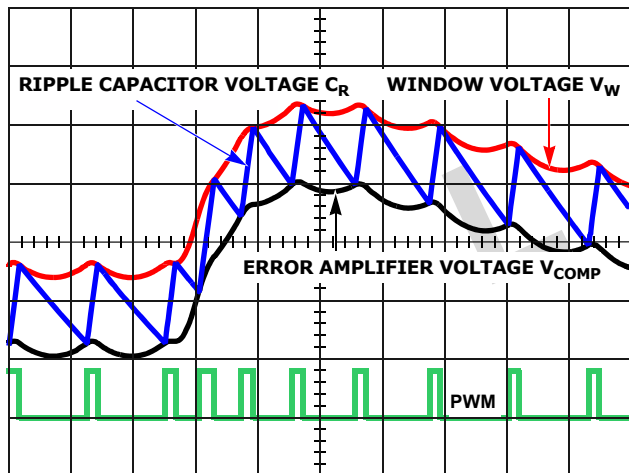

FIGURE 6. MODULATOR WAVEFORMS DURING LOAD TRANSIENT

Initialization

Once sufficient bias is applied to the VCC pin, internal logic checks the status of critical pins to determine the controller operation profile prior to ENABLE. These pins include RTN1 which determines single vs two-phase operation and OFS/VFIXEN for enabling/disabling the SVI interface and core voltage droop. Depending on the configuration set by these pins, the controller then checks the state of the SVC and SVD pins to determine the soft-start target output voltage level.

Power-On Reset

The ISL6265C requires a +5V input supply tied to VCC and PVCC to exceed a rising power-on reset (POR) threshold before the controller has sufficient bias to guarantee proper operation. Once this threshold is reached or exceeded, the ISL6265C has enough bias to begin checking RTN1, OFS/VFIXEN, ENABLE, and SVI inputs. Hysteresis between the rising and falling thresholds assure the ISL6265C will not inadvertently turn-off unless the bias voltage drops substantially (see "Electrical Specifications" on page 12).

Core Configuration

The ISL6265C determines the core channel requirements of the CPU based on the state of the RTN1 pin prior to ENABLE. If RTN1 is low prior to ENABLE, both VDD0 and VDD1 core planes are required. The core controllers operate as independent single-phase regulators. RTN1 is connected to the CPU Core1 negative sense point. For single core CPU designs (uniplane), RTN1 is tied to a +1.8V or greater supply. Prior to ENABLE, RTN1 is detected as HIGH and the ISL6265C drives the core controllers as a two-phase multi-phase regulator. Dual purpose motherboard designs should include resistor options to open the CPU Core1 negative sense and connect the RTN1 pin to a pull-up resistor.

Mode Selection

The OFS/VFIXEN pin selects between the AMD defined VFIX and SVI modes of operation and enables droop if desired in SVI mode only. If OFS/VFIXEN is tied to VCC, then SVI mode with no droop on the core output(s) is selected. Connected to +3.3V, VFIX mode is active with no droop on the core output(s). SVI mode with droop is enabled when OFS/VFIXEN is tied to ground through a resistor sized to set the core voltage positive offset. Further information is provided in "Offset Resistor Selection" on page 19.

Serial VID Interface

The on-board Serial VID Interface (SVI) circuitry allows the processor to directly control the Core and Northbridge voltage reference levels within the ISL6265C. The SVC and SVD states are decoded according to the PWROK and VFIXEN inputs as described in the following sections. The ISL6265C uses a digital-to-analog converter (DAC) to generate a reference voltage based on the decoded SVI value. See Figure 7 for a simple SVI interface timing diagram.

Pre-PWROK Metal VID

Assuming the OFS/VFIXEN pin is not tied to +3.3V during controller configuration, typical motherboard start-up begins with the controller decoding the SVC and SVD inputs to determine the pre-PWROK metal VID setting (see Table 1). Once the enable input (EN) exceeds the rising enable threshold, the ISL6265C decodes and locks the decoded value in an on-board hold register.

The internal DAC circuitry begins to ramp Core and Northbridge planes to the decoded pre-PWROK metal VID output level. The digital soft-start circuitry ramps the internal reference to the target gradually at a fixed rate of approximately 2mV/ μ s. The controlled ramp of all output voltage planes reduces in-rush current during the soft-start interval. At the end of the soft-start interval, the PGOOD output transitions high indicating all output planes are within regulation limits.

TABLE 1. PRE-PWROK METAL VID CODES

SVC	SVD	OUTPUT VOLTAGE (V)
0	0	1.1
0	1	1.0
1	0	0.9
1	1	0.8

If the EN input falls below the enable falling threshold, the ISL6265C tri-states all outputs. PGOOD is pulled low with the loss of EN. The Core and Northbridge planes will decay based on output capacitance and load leakage resistance. If bias to VCC falls below the POR level, the ISL6265C responds in the same manner previously described. Once VCC and EN rise above their respective rising thresholds, the internal DAC circuitry re-acquires a pre-PWROK metal VID code and the controller soft-starts.

VFIX MODE

In VFIX Mode, the SVC and SVD levels fixed external to the controller through jumpers to either GND or VDDIO. These inputs are not expected to change. In VFIX mode, the IC decodes the SVC and SVD states per Table 2.

TABLE 2. VFIXEN VID CODES

SVC	SVD	OUTPUT VOLTAGE (V)
0	0	1.4
0	1	1.2
1	0	1.0
1	1	0.8

Once enabled, the ISL6265C begins to soft-start both Core and Northbridge planes to the programmed VFIX level. The internal soft-start circuitry slowly ramps the reference up to the target value. The same fixed internal rate of approximately 2mV/μs results in a controlled ramp of the power planes. Once soft-start has ended and all output planes are within regulation limits, the PGOOD pin transitions high.

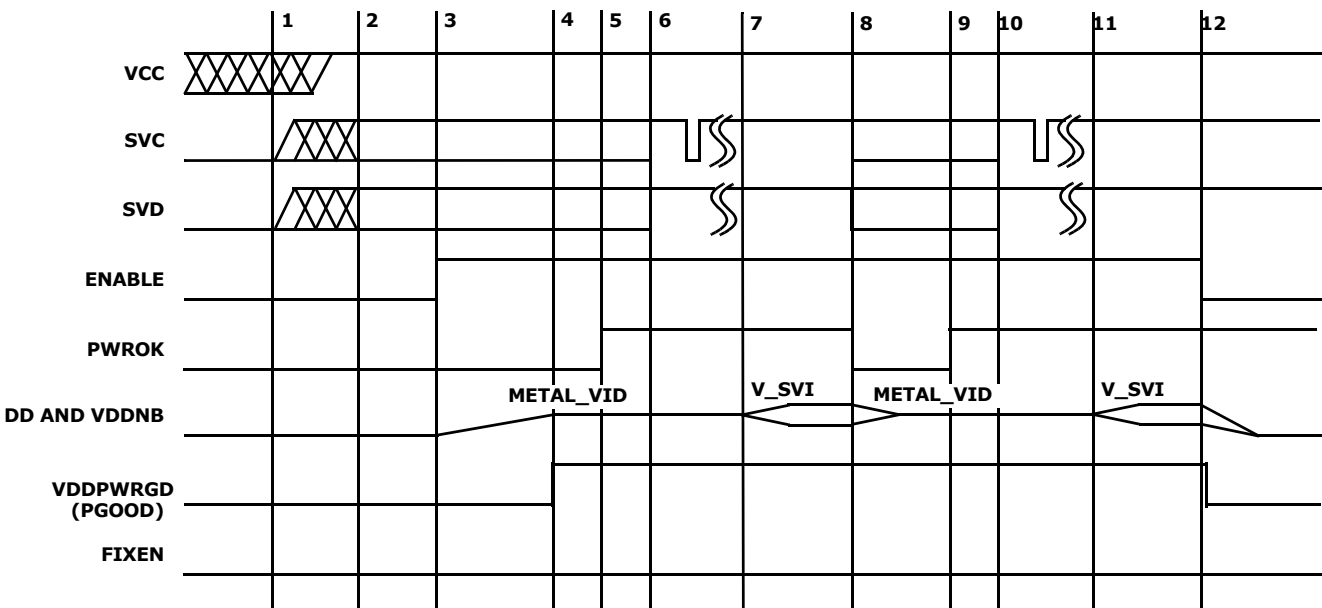

- Interval 1 to 2: ISL6265C waits to POR.
- Interval 2 to 3: SVC and SVD are externally set to pre-Metal VID code.
- Interval 3 to 4: EN locks core output configuration and pre-Metal VID code. All outputs soft-start to this level.
- Interval 4 to 5: PGOOD signal goes HIGH indicating proper operation.
- Interval 5 to 6: CPU detects VDDPWRGD high and drives PWROK high to allow ISL6265C to prepare for SVI code.
- Interval 6 to 7: SVC and SVD data lines communicate change in VID code.
- Interval 7 to 8: ISL6265C responds to VID-ON-THE-FLY code change.
- Interval 8 to 9: PWROK is driven low and ISL6265C returns all outputs to pre-PWROK Metal VID level.
- Interval 9 to 10: PWROK driven high once again by CPU and ISL6265C prepares for SVI code.
- Interval 10 to 11: SVC and SVD data lines communicate new VID code.
- Interval 11 to 12: ISL6265C drives outputs to new VID code level.
- Post 12 : Enable falls and all internal drivers are tri-stated and PGOOD is driven low.

FIGURE 7. SVI INTERFACE TIMING DIAGRAM: TYPICAL PRE-PWROK METAL VID STARTUP

In the same manner described in “Pre-PWROK Metal VID” on page 14, the POR circuitry impacts the internal driver operation and PGOOD status.

SVI MODE

Once the controller has successfully soft-started and PGOOD transitions high, the processor can assert PWROK to signal the ISL6265C to prepare for SVI commands. The controller actively monitors the SVI interface for set VID commands to move the plane voltages to start-up VID values. Details of the SVI Bus protocol are provided in the AMD Design Guide for Voltage Regulator Controllers Accepting Serial VID Codes specification.

Once a set VID command is received, the ISL6265C decodes the information to determine which output plane is affected and the VID target required (see Table 3). The internal DAC circuitry steps the required output plane voltage to the new VID level. During this time, one or more of the planes could be targeted. In the event either core voltage plane, VDD0 or VDD1, is commanded to power-off by serial VID commands, the PGOOD signal remains asserted. The Northbridge voltage plane must remain active during this time.

If the PWROK input is de-asserted, then the controller steps both Core and Northbridge planes back to the stored pre-PWROK metal VID level in the holding register from initial soft-start. No attempt is made to read the SVC and SVD inputs during this time. If PWROK is reasserted, then the on-board SVI interface waits for a set VID command.

If EN goes low during normal operation, all internal drivers are tri-stated and PGOOD is pulled low. This event clears the pre-PWROK metal VID code and forces the controller to check SVC and SVD upon restart.

A POR event on VCC during normal operation will shutdown all regulators and PGOOD is pulled low. The pre-PWROK metal VID code is not retained.

VID-On-the-Fly Transition

Once PWROK is high, the ISL6265C detects this flag and begins monitoring the SVC and SVD pins for SVI instructions. The microprocessor will follow the protocol outlined in the following sections to send instructions for VID-on-the-Fly transitions. The ISL6265C decodes the instruction and acknowledges the new VID code. For VID codes higher than the current VID level, the ISL6265C begins stepping the required regulator output(s) to the new VID target with a typical slew rate of 7.5mV/μs, which meets the AMD requirements.

When the VID codes are lower than the current VID level, the ISL6265C begins stepping the regulator output to the new VID target with a typical slew rate of -7.5mV/μs. Both Core and NB regulators are always in CCM during a down VID transition. The AMD requirements under these conditions do not require the regulator to meet the minimum slew rate specification of -5mV/μs. In either case, the slew rate is not allowed to exceed 10mV/μs. The ISL6265C does not change the state of PGOOD (VDDPWRGD in AMD specifications) when a VID-on-the-fly transition occurs.

SVI WIRE Protocol

The SVI wire protocol is based on the I²C bus concept. Two wires (serial clock (SVC) and serial data (SVD)), carry information between the AMD processor (master) and VR controller (slave) on the bus. The master initiates and terminates SVI transactions and drives the clock, SVC, during a transaction. The AMD processor is *always* the master and the voltage regulators are the slaves. The slave receives the SVI transactions and acts accordingly. Mobile SVI wire protocol timing is based on high-speed mode I²C. See AMD Griffin (Family 11h) processor publications for additional details.

TABLE 3. SERIAL VID CODES

SVID[6:0]	VOLTAGE (V)	SVID[6:0]	VOLTAGE (V)	SVID[6:0]	VOLTAGE (V)	SVID[6:0]	VOLTAGE (V)
000_0000b	1.5500	010_0000b	1.1500	100_0000b	0.7500	110_0000b	0.3500*
000_0001b	1.5375	010_0001b	1.1375	100_0001b	0.7375	110_0001b	0.3375*
000_0010b	1.5250	010_0010b	1.1250	100_0010b	0.7250	110_0010b	0.3250*
000_0011b	1.5125	010_0011b	1.1125	100_0011b	0.7125	110_0011b	0.3125*
000_0100b	1.5000	010_0100b	1.1000	100_0100b	0.7000	110_0100b	0.3000*
000_0101b	1.4875	010_0101b	1.0875	100_0101b	0.6875	110_0101b	0.2875*
000_0110b	1.4750	010_0110b	1.0750	100_0110b	0.6750	110_0110b	0.2750*
000_0111b	1.4625	010_0111b	1.0625	100_0111b	0.6625	110_0111b	0.2625*
000_1000b	1.4500	010_1000b	1.0500	100_1000b	0.6500	110_1000b	0.2500*
000_1001b	1.4375	010_1001b	1.0375	100_1001b	0.6375	110_1001b	0.2375*
000_1010b	1.4250	010_1010b	1.0250	100_1010b	0.6250	110_1010b	0.2250*
000_1011b	1.4125	010_1011b	1.0125	100_1011b	0.6125	110_1011b	0.2125*

ISL6265C

TABLE 3. SERIAL VID CODES (Continued)

SVID[6:0]	VOLTAGE (V)	SVID[6:0]	VOLTAGE (V)	SVID[6:0]	VOLTAGE (V)	SVID[6:0]	VOLTAGE (V)
000_1100b	1.4000	010_1100b	1.0000	100_1100b	0.6000	110_1100b	0.2000*
000_1101b	1.3875	010_1101b	0.9875	100_1101b	0.5875	110_1101b	0.1875*
000_1110b	1.3750	010_1110b	0.9750	100_1110b	0.5750	110_1110b	0.1750*
000_1111b	1.3625	010_1111b	0.9625	100_1111b	0.5625	110_1111b	0.1625*
001_0000b	1.3500	011_0000b	0.9500	101_0000b	0.5500	111_0000b	0.1500*
001_0001b	1.3375	011_0001b	0.9375	101_0001b	0.5375	111_0001b	0.1375*
001_0010b	1.3250	011_0010b	0.9250	101_0010b	0.5250	111_0010b	0.1250*
001_0011b	1.3125	011_0011b	0.9125	101_0011b	0.5125	111_0011b	0.1125*
001_0100b	1.3000	011_0100b	0.9000	101_0100b	0.5000	111_0100b	0.1000*
001_0101b	1.2875	011_0101b	0.8875	101_0101b	0.4875*	111_0101b	0.0875*
001_0110b	1.2750	011_0110b	0.8750	101_0110b	0.4750*	111_0110b	0.0750*
001_0111b	1.2625	011_0111b	0.8625	101_0111b	0.4625*	111_0111b	0.0625*
001_1000b	1.2500	011_1000b	0.8500	101_1000b	0.4500*	111_1000b	0.0500*
001_1001b	1.2375	011_1001b	0.8375	101_1001b	0.4375*	111_1001b	0.0375*
001_1010b	1.2250	011_1010b	0.8250	101_1010b	0.4250*	111_1010b	0.0250*
001_1011b	1.2125	011_1011b	0.8125	101_1011b	0.4125*	111_1011b	0.0125*
001_1100b	1.2000	011_1100b	0.8000	101_1100b	0.4000*	111_1100b	OFF
001_1101b	1.1875	011_1101b	0.7875	101_1101b	0.3875*	111_1101b	OFF
001_1110b	1.1750	011_1110b	0.7750	101_1110b	0.3750*	111_1110b	OFF
001_1111b	1.1625	011_1111b	0.7625	101_1111b	0.3625*	111_1111b	OFF

NOTE: *Indicates a VID not required for AMD Family 10h processors.

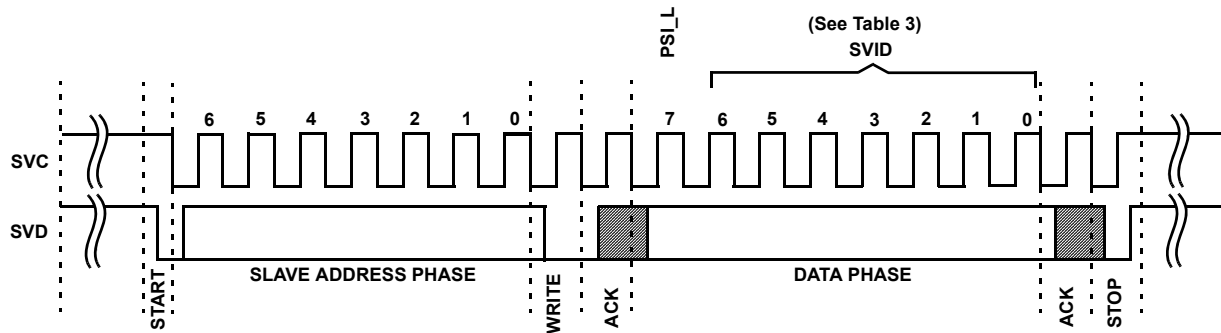

FIGURE 8. SEND BYTE EXAMPLE

SVI Bus Protocol

The AMD processor bus protocol is compliant with SMBus send byte protocol for VID transactions (see Figure 8). During a send byte transaction, the processor sends the start sequence followed by the slave address of the VR for which the VID command applies. The address byte must be configured according to Table 4. The processor then sends the write bit. After the write bit, if the ISL6265C receives a valid address byte, it sends the acknowledge bit. The processor then sends the PSI-L bit and VID bits during the data phase. The Serial VID 8-bit

data field encoding is outlined in Table 5. If ISL6265C receives a valid 8-bit code during the data phase, it sends the acknowledge bit. Finally, the processor sends the stop sequence. After the ISL6265C has detected the stop, it can then proceed with the VID-on-the-fly transition.

TABLE 4. SVI SEND BYTE ADDRESS DESCRIPTION

BITS	DESCRIPTION
6:4	Always 110b
3	Reserved by AMD for future use

TABLE 4. SVI SEND BYTE ADDRESS DESCRIPTION

BITS	DESCRIPTION
2	VDD1, if set then the following data byte contains the VID for VDD1
1	VDD0, if set then the following data byte contains the VID for VDD0
0	VDDNB, if set then the following data byte contains the VID for VIDNB

TABLE 5. SERIAL VID 8-BIT DATA FIELD ENCODING

BITS	DESCRIPTION
7	PSI_L: =0 means the processor is at an optimal load for the regulator(s) to enter power-savings mode =1 means the processor is not at an optimal load for the regulator(s) to enter power-saving mode
6:0	SVID[6:0] as defined in Table 3.

Operation

After the start-up sequence, the ISL6265C begins regulating the core and Northbridge output voltages to the pre-PWROK metal VID programmed. The controller monitors SVI commands to determine when to enter power-savings mode, implement dynamic VID changes, and shutdown individual outputs.

The ISL6265C controls the no-load output voltage of core and Northbridge output to an accuracy of ±0.5% over-the-range of 0.75V to 1.5V. A fully differential amplifier implements core voltage sensing for precise voltage control at the microprocessor die.

Switching Frequency

The R³ modulator scheme is a variable frequency PWM architecture. The switching frequency increases during the application of a load to improve transient performance. It also varies slightly due to changes in input and output voltage and output current. This variation is normally less than 10% in continuous conduction mode.

CORE FREQUENCY SELECTION

A resistor connected between the VW and COMP pins of the Core segment of the ISL6265C adjusts the switching window and therefore adjusts the switching frequency. The R_{FSET} resistor that sets up the switching frequency of the converter operating in CCM can be determined using Equation 3, where R_{FSET} is in kΩ and the switching period is in ms. Designs for 300kHz switching frequency would result in a R_{FSET} value of 6.81kΩ

$$R_{FSET}(k\Omega) = (\text{Period}(\mu\text{s}) - 0.4) \times 2.33 \quad (\text{EQ. 3})$$

In discontinuous conduction mode (DCM) the ISL6265C runs in period stretching mode.

NORTHBRIDGE FREQUENCY SELECTION

The Northbridge switching frequency is programmed by a resistor connected from the FSET_NB pin to the GND pin. The approximate PWM switching frequency is written as shown in Equation 4:

$$F_{SW} = \frac{1}{K \cdot R_{FSETNB}} \quad (\text{EQ. 4})$$

Estimating the value of R_{FSET_NB} is written as shown in Equation 5:

$$R_{FSET} = \frac{1}{K \cdot F_{SW}} \quad (\text{EQ. 5})$$

Where F_{SW} is the PWM switching frequency, R_{FSET_NB} is the programming resistor and K = 1.5 × 10⁻¹⁰.

It is recommended that whenever the control loop compensation network is modified, the switching frequency should be checked and adjusted by changing R_{FSET_NB} if necessary.

Current Sense

Core and Northbridge regulators feature two different types of current sense circuits.

CORE CONTINUOUS CURRENT SENSE

The ISL6265C provides for load current to be measured using either resistors in series with the individual output inductors or using the intrinsic series resistance of the inductors as shown in the applications circuits in Figures 2 and 3. The load current in a particular output is sampled continuously every switching cycle. During this time, the current-sense amplifier uses the current sense inputs to reproduce a signal proportional to the inductor current. This sensed current is a scaled version of the inductor current.

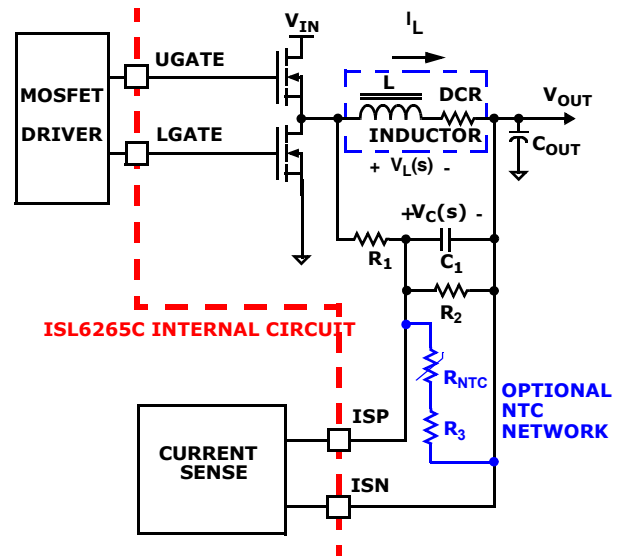

FIGURE 9. DCR SENSING COMPONENTS

Inductor windings have a characteristic distributed resistance or DCR (Direct Current Resistance). For simplicity, the inductor DCR is considered as a separate lumped quantity, as shown in Figure 9. The inductor current, I_L , flowing through the inductor, passes through the DCR. Equation 6 shows the s-domain equivalent voltage, V_L , across the inductor.

$$V_L(s) = I_L \cdot (s \cdot L + DCR) \quad (\text{EQ. 6})$$

A simple R-C network across the inductor (R_1 , R_2 and C) extracts the DCR voltage, as shown in Equation 7. The voltage across the sense capacitor, V_C , can be shown to be proportional to the output current I_L , shown in Equation 7.

$$V_C(s) = \frac{\left(\frac{s \cdot L}{DCR} + 1\right)}{\left(s \cdot \frac{(R_1 \cdot R_2)}{R_1 + R_2} \cdot C_1 + 1\right)} \cdot K \cdot DCR \cdot I_L \quad (\text{EQ. 7})$$

Where:

$$K = \frac{R_2}{R_2 + R_1} \quad (\text{EQ. 8})$$

Sensing the time varying inductor current accurately requires that the parallel R-C network time constant match the inductor L/DCR time constant. If the R-C network components are selected, such that the R-C time constant matches the inductor L/DCR time constant (see Equation 9), then V_C is equal to the voltage drop across the DCR multiplied by the ratio of the resistor divider, K.

$$\frac{L}{DCR} = \frac{R_1 \cdot R_2}{R_1 + R_2} \cdot C_1 \quad (\text{EQ. 9})$$

The inductor current sense information is used for current balance in dual plane applications, overcurrent detection in core outputs and output voltage droop depending on controller configuration.

CORE DCR TEMPERATURE COMPENSATION

It may also be necessary to compensate for changes in inductor DCR due to temperature. DCR shifts due to temperature cause time constant mismatch, skewing inductor current accuracy. Potential problems include output voltage droop and OC trip point, both shifting significantly from expected levels. The addition of a negative temperature coefficient (NTC) resistor to the R-C network compensates for the rise in DCR due to temperature. Typical NTC values are in the 10kΩ range. A second resistor, R_3 , in series with the NTC allows for more accurate time-constant and resistor-ratio matching as the pair of resistors are placed in parallel with R_2 (Figure 9). The NTC resistor must be placed next to the inductor for good heat transfer, while R_1 , R_2 , R_3 , and C_1 are placed close to the controller for interference immunity.

CORE DCR COMPONENT SELECTION FOR DROOP

By adjusting the ratio between inductor DCR drop and the voltage measured across the sense capacitor, the

load line can be set to any level, giving the converter the correct amount of droop at all load currents.

Equation 10 shows the relation between droop voltage, maximum output current (I_{MAX}), OC trip level and current sense capacitor voltage at the OC current level, $V_{C(OC)}$.

$$V_{DROOP} = \frac{I_{MAX}}{I_{OC}} \cdot 5 \cdot V_{C, OC} \quad (\text{EQ. 10})$$

AMD specifications do not require droop and provide no load line guidelines. Tight static output voltage tolerance limits push acceptable level of droop below a useful level for Griffin applications. Care must be taken in applications which implement droop to balance time constant mismatch, sense capacitor resistor ratio, OC trip and droop equations. Temperature shifts related to DCR must also be addressed, as outlined in the previous section.

NORTHBRIDGE CURRENT SENSE

During the off-time following a PHASE transition low, the Northbridge controller samples the voltage across the lower MOSFET $r_{DS(ON)}$. A ground-referenced amplifier is connected to the PHASE node through a resistor, R_{OCSET_NB} . The voltage across R_{OCSET_NB} is equal to the voltage drop across the $r_{DS(ON)}$ of the lower MOSFET while it is conducting. The resulting current into the OCSET_NB pin is proportional to the inductor current. The sensed inductor current is used for overcurrent protection and described in the "Fault Monitoring and Protection" on page 21. The Northbridge controller does not support output voltage droop.

Selecting RBIAS For Core Outputs

To properly bias the ISL6265C, a reference current is established by placing a 117kΩ, 1% tolerance resistor from the RBIAS pin to ground. This will provide a highly accurate, 10μA current source from which OC reference current is derived.

Care must be taken in layout to place the resistor very close to the RBIAS pin. A good quality signal ground should be connected to the opposite end of the R_{BIAS} resistor. Do not connect any other components to this pin as this would negatively impact performance. Capacitance on this pin could create instabilities and is to be avoided.

A resistor divider off this pin is used to set the Core side OC trip level. Additional direction on how to size is provided in "Fault Monitoring and Protection" on page 21 on how to size the resistor divider.

Offset Resistor Selection

If the OFS pin is connected to ground through a resistor, the ISL6265C operates in SVI mode with droop active. The resistor between the OFS pin and ground sets the positive Core voltage offset per Equation 11.

$$R_{OFS} = \frac{1.2V \cdot R_{FB}}{V_{OFS}} \quad (\text{EQ. 11})$$

Where V_{OFS} is the user defined output voltage offset. Typically, V_{OFS} is determined by taking half the total output voltage droop. The resulting value centers the overall output voltage waveform around the programmed SVID level. For example, R_{FB} of $1k\Omega$ and a total output droop of $24mV$ would result in an offset voltage of $12mV$ and a R_{OFS} of $100k\Omega$.

Internal Driver Operation

The ISL6265C features three internal gate-drivers to support the Core and Northbridge regulators and to reduce solution size. The drivers include a diode emulation mode, which helps to improve light-load efficiency.

MOSFET Gate-Drive Outputs

The ISL6265C has internal gate-drivers for the high-side and low-side N-Channel MOSFETs. The low-side gate-drivers are optimized for low duty-cycle applications where the low-side MOSFET conduction losses are dominant, requiring a low $r_{DS(ON)}$ MOSFET. The LGATE pull-down resistance is low in order to strongly clamp the gate of the MOSFET below the $V_{GS(th)}$ at turn-off. The current transient through the gate at turn-off can be considerable because the gate charge of a low $r_{DS(ON)}$ MOSFET can be large. Adaptive shoot-through protection prevents a gate-driver output from turning on until the opposite gate-driver output has fallen below approximately $1V$.

The high-side gate-driver output voltage is measured across the UGATE and PHASE pins while the low-side gate-driver output voltage is measured across the LGATE and PGND pins. The power for the LGATE gate driver is sourced directly from the PVCC pin. The power for the UGATE gate-driver is sourced from a "boot" capacitor connected across the BOOT and PHASE pins. The boot capacitor is charged from a $5V$ bias supply through a "boot diode" each time the low-side MOSFET turns on, pulling the PHASE pin low. The ISL6265C has an integrated boot diode connected from the PVCC pin to the BOOT pin.

Diode Emulation

The ISL6265C implements forced continuous-conduction-mode (CCM) at heavy load and diode-emulation-mode (DE) at light load, to optimize efficiency in the entire load range. The transition is automatically achieved by detecting the inductor current when PSI_L is low. If PSI_L is high, the controller disables DE and forces CCM on both Core and NB regulators.

Positive-going inductor current flows either from the source of the high-side MOSFET, or into the drain of the low-side MOSFET. Negative-going inductor current flows into the drain of the low-side MOSFET. When the low-side MOSFET conducts positive inductor current, the phase voltage is negative with respect to the GND and PGND pins. Conversely, when the low-side MOSFET conducts negative inductor current, the phase voltage is positive with respect to the GND and PGND pins. The ISL6265C

monitors the phase voltage when the low-side MOSFET is conducting inductor current to determine the direction of the inductor current.

When the output load current is less than half the inductor ripple current, the inductor current goes negative. Sinking the negative inductor through the low-side MOSFET lowers efficiency by preventing DCM period stretching and allowing unnecessary conduction losses. In DE, the ISL6265C Core regulators automatically enter DCM after the PHASE pin has detected positive voltage and LGATE was allowed to go high. The NB regulator enters DCM after the PHASE pin has detected positive voltage and LGATE was allowed to go high for eight consecutive PWM switching cycles. The ISL6265C turns off the low-side MOSFET once the phase voltage turns positive, indicating negative inductor current. The ISL6265C returns to CCM on the following cycle after the PHASE pin detects negative voltage, indicating that the body diode of the low-side MOSFET is conducting positive inductor current.

Efficiency can be further improved with a reduction of unnecessary switching losses by reducing the PWM frequency. It is characteristic of the R^3 architecture for the PWM frequency to decrease while in diode emulation. The extent of the frequency reduction is proportional to the reduction of load current. Upon entering DCM, the PWM frequency makes an initial step-reduction because of a 33% step-increase of the window voltage V_W .

Power-Savings Mode

The ISL6265C has two operating modes to optimize efficiency based on the state of the PSI_L input from the AMD SVI control signal. When this input is low, the controller expects to deliver low power and enters a power-savings mode to improve efficiency in this low power state. The controller's operational modes are designed to work in conjunction with the AMD SVI control signal to maintain the optimal system configuration for all conditions.

Northbridge And Dual Plane Core

While PSI_L is high, the controller operates all three regulators in forced CCM. If PSI_L is asserted low by the SVI interface, the ISL6265C initiates DE in all three regulators. This transition allows the controller to achieve the highest possible efficiency over the entire load range for each output. A smooth transition is facilitated by the R^3 technology™, which correctly maintains the internally synthesized ripple current throughout mode transitions of each regulator.

Uniplane Core

In uniplane mode, the ISL6265C Core regulator is in 2-phase multiphase mode. The controller operates with both phases fully active, responding rapidly to transients and delivering the maximum power to the load. When the processor asserts PSI_L low under reduced load levels, the ISL6265C sheds one phase to eliminate switching losses associated with the idle channel. Even

with the regulator operating in single-phase mode, transient response capability is maintained.

While operating in single-phase DE with PSI_L low, the lower MOSFET driver switches the lower MOSFET off at the point of zero inductor current to prevent discharge current from flowing from the output capacitor bank through the inductor. In DCM, switching frequency is proportionately reduced, thus greatly reducing both conduction and switching loss. In DCM, the switching frequency is defined by Equation 12.

$$F_{DCM} = \frac{F_{CCM}^2}{1.33^2} \cdot \frac{2 \cdot L \cdot I_O}{V_O \cdot \left(1 - \frac{V_O}{V_{IN}}\right)} \quad (\text{EQ. 12})$$

Where F_{CCM} is equivalent to the Core frequency set by Equation 3.

Fault Monitoring and Protection

The ISL6265C actively monitors Core and Northbridge output voltages and currents to detect fault conditions. These fault monitors trigger protective measures to prevent damage to the processor. One common power good indicator is provided for linking to external system monitors.

Power-Good Signal

The power-good pin (PGOOD) is an open-drain logic output that signals if the ISL6265C is not regulating Core and Northbridge output voltages within the proper levels or output current in one or more outputs has exceeded the maximum current setpoint.

This pin must be tied to a +3.3V or +5V source through a resistor. During shutdown and soft-start, PGOOD is pulled low and is released high only after a successful soft-start has raised Core and Northbridge output voltages within operating limits. PGOOD is pulled low when an overvoltage, undervoltage, or overcurrent (OC) condition is detected on any output or when the controller is disabled by a POR or forcing enable (EN) low. Once a fault condition is triggered, the controller acts to protect the processor. The controller latches off and PGOOD is pulled low. Toggling EN or VCC initiates a soft-start of all outputs. In the event of an OV, the controller will not initiate a soft-start by toggling EN, but requires VCC be lowered below the falling POR threshold to reset.

Overcurrent Protection

Core and Northbridge outputs feature two different methods of current sensing. Core output current sensing is achieved via inductor DCR or discrete resistor sensing. The Northbridge controller uses lower MOSFET $r_{DS(ON)}$ sensing to detect output current.

CORE OC DETECTION

Core outputs feature an OC monitor which compares a voltage set at the OCSET pin to the voltage measured across the current sense capacitor, V_C . When the voltage across the current sense capacitor exceeds the

programmed trip level, the comparator signals an OC fault. Figure 10 shows the basic OC functions within the IC.

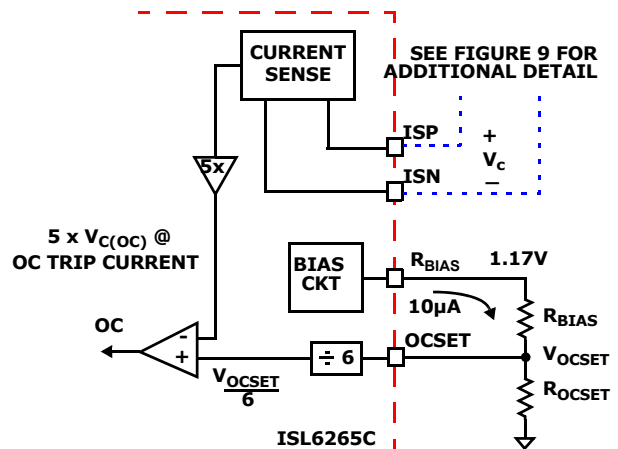

FIGURE 10. OC TRIP CIRCUITRY

The sense capacitor voltage, V_C , will increase as inductor current rises per Equation 7. When the inductor current rises to the OC trip level, the voltage across the sense capacitor will reach a maximum based on the resistor ratio K . This maximum value, $V_{C(OC)}$, is gained up by a factor of 5 and compared to the static OC trip level set by the OCSET pin.

The recommended voltage range for $V_{C,OC}$ is 6mV to 25mV, which sets the resistor divider ratio K , where I_{OC} is the user-defined OC trip level (see Equation 13). Typical inductor DCR values are on the order of 1mΩ which result in more than enough voltage drop to support this $V_{C,OC}$ range.

$$K = \frac{V_{C(OC)}}{I_{OC} \cdot DCR} \quad (\text{EQ. 13})$$

The resistor divider components also impact time-constant matching, these components need to meet the parallel combination requirements of Equation 9.

Based on the selected $V_{C(OC)}$ level, the required OC monitor trip level is set. The recommended $V_{C(OC)}$ level range will result in an OC monitor trip level range of 30mV to 125mV based on the internal gain of 5.

This OC monitor trip level sets the voltage level required at the OCSET pin to create an OC fault at the user-defined OC trip level. A resistor divider from the RBIAS pin to ground with the mid-point connected to OCSET sets the voltage at the pin (see Figure 10). This voltage is internally divided by 6 and compared with $V_{C(OC)}$. Working backwards, the voltage required at the OCSET pin to achieve this OC trip level ranges from 180mV to 0.750mV as defined in Equation 14.

$$V_{OCSET} = V_{C(OC)} \cdot 30 \quad (\text{EQ. 14})$$

The resistor divider ratio used to determine the R_{BIAS} and R_{OCSET} values is shown in Equation 15.

$$\frac{R_{OCSET}}{R_{OCSET} + R_{BIAS}} = \frac{V_{OCSET}}{1.17V} \quad (\text{EQ. 15})$$

The resistor values must also meet the R_{BIAS} requirement that the total series resistance to ground equal 117k Ω . An OC condition must be sustained for 100 μ s before action is taken by the controller in response to the OC fault.

A short-circuit OC loop is also active based on the same sense elements outlined above with a threshold set to 2.25x the OCSET threshold set. The controller takes immediate action when this fast OC fault is detected.

NORTHBRIDGE OC DETECTION

Northbridge OC sensing is achieved via $r_{DS(ON)}$ sensing across the lower MOSFET. An internal 10 μ A current source develops a voltage across R_{OCSET_NB} , which is compared with the voltage developed across the low-side MOSFET as measured at the PHASE pin. When the voltage drop across the MOSFET exceeds the voltage drop across the resistor, an OC event occurs. The OCSET_NB resistor is selected based on the relationship in Equation 16.

$$R_{OCSETNB} = \frac{I_{OC} \cdot r_{DS(ON)}}{10\mu A} \quad (\text{EQ. 16})$$

Where I_{OC} is the OC trip level selected for the Northbridge application and $r_{DS(ON)}$ is the drain-source ON-resistance of the lower MOSFET.

OC FAULT RESPONSE

When an OC fault occurs on any combination of outputs, both Core and Northbridge regulators shutdown and the driver outputs are tri-stated. The PGOOD signal transitions low indicating a fault condition. The controller will not attempt to restart the regulators and the user must toggle either EN or VCC to clear the fault condition.

Overvoltage Protection

The ISL6265C monitors the individual Core and Northbridge output voltages using differential remote sense amplifiers. The ISL6265C features a severe overvoltage (OV) threshold of 1.8V. If any of the outputs exceed this voltage, an OV fault is immediately triggered. PGOOD is latched low and the low-side MOSFETs of the offending output(s) are turned on. The low-side MOSFETs will remain on until the output voltage is pulled below 0.85V at which time all MOSFETs are turned off. If the output again rises above 1.8V, the protection process repeats. This offers protection against a shorted high-side MOSFET while preventing output voltage from ringing below ground. The OV is reset by toggling EN low. OV detection is active at all times that the controller is enabled including after one of the other faults occurs so that the processor is protected against high-side MOSFET leakage while the MOSFETs are commanded off.

Undervoltage Protection

Undervoltage protection is independent of the OC limit. A fault latches if any of the sensed output voltages are less

than the VID set value by a nominal 295mV for 205 μ s. The PWM outputs turn off both Core and Northbridge internal drivers and PGOOD goes low.

General Application Design Guide

This design guide is intended to provide a high-level explanation of the steps necessary to design a single-phase power converter. It is assumed that the reader is familiar with many of the basic skills and techniques referenced in the following section. In addition to this guide, Intersil provides complete reference designs that include schematics, bills of materials, and example board layouts.

Selecting the LC Output Filter

The output inductor and output capacitor bank form a low-pass filter responsible for smoothing the pulsating voltage at the phase node. The output filter also must support the transient energy required by the load until the controller can respond. Because it has a low bandwidth compared to the switching frequency, the output filter limits the system transient response. The output capacitors must supply or sink load current while the current in the output inductors increases or decreases to meet the demand.

The duty cycle of an ideal buck converter is a function of the input and the output voltage. This relationship is written as Equation 17:

$$D = \frac{V_O}{V_{IN}} \quad (\text{EQ. 17})$$

The output inductor peak-to-peak ripple current is written as Equation 18:

$$I_{P-P} = \frac{V_O \cdot (1 - D)}{f_{SW} \cdot L} \quad (\text{EQ. 18})$$

For this type of application, a typical step-down DC/DC converter has an I_{P-P} of 20% to 40% of the maximum DC output load current. The value of I_{P-P} is selected based upon several criteria such as MOSFET switching loss, inductor core loss, and the resistive loss of the inductor winding. The DC copper loss of the inductor can be estimated by Equation 19:

$$P_{COPPER} = I_{LOAD}^2 \cdot DCR \quad (\text{EQ. 19})$$

Where I_{LOAD} is the converter output DC current.

The copper loss can be significant so attention must be given to the DCR selection. Another factor to consider when choosing the inductor is its saturation characteristics at elevated temperature. A saturated inductor could cause destruction of circuit components as well as nuisance OCP faults.

A DC/DC buck regulator must have output capacitance C_O into which ripple current I_{P-P} can flow. Current I_{P-P} develops a corresponding ripple voltage V_{P-P} across C_O , which is the sum of the voltage drop across the capacitor

ESR and of the voltage change stemming from charge moved in and out of the capacitor. These two voltages are written as shown in Equation 20:

$$\Delta V_{ESR} = I_{PP} \cdot ESR \quad (EQ. 20)$$

and Equation 21:

$$\Delta V_C = \frac{I_{PP}}{8 \cdot C_O \cdot f_{SW}} \quad (EQ. 21)$$

If the output of the converter has to support a load with high pulsating current, several capacitors will need to be paralleled to reduce the total ESR until the required V_{P-P} is achieved. The inductance of the capacitor can cause a brief voltage dip if the load transient has an extremely high slew rate. Capacitor ESL can significantly impact output voltage ripple. Low inductance capacitors should be considered. A capacitor dissipates heat as a function of RMS current and frequency. Be sure that I_{P-P} is shared by a sufficient quantity of paralleled capacitors so that they operate below the maximum rated RMS current at f_{SW} . Take into account that the rated value of a capacitor can degrade as much as 50% as the DC voltage across it increases.

Selection of the Input Capacitor

The input capacitors are responsible for sourcing the AC component of the input current flowing into the upper MOSFETs. Their RMS current capability must be sufficient to handle the AC component of the current drawn by the upper MOSFETs, which is related to duty cycle and the number of active phases.

The important parameters for the bulk input capacitance are the voltage rating and the RMS current rating. For reliable operation, select bulk capacitors with voltage and current ratings above the maximum input voltage and capable of supplying the RMS current required by the switching circuit. Their voltage rating should be at least 1.25x greater than the maximum input voltage, while a voltage rating of 1.5x is a preferred rating. Figure 11 is a graph of the input RMS ripple current, normalized relative to output load current, as a function of duty cycle for a single-phase regulator that is adjusted for converter efficiency.

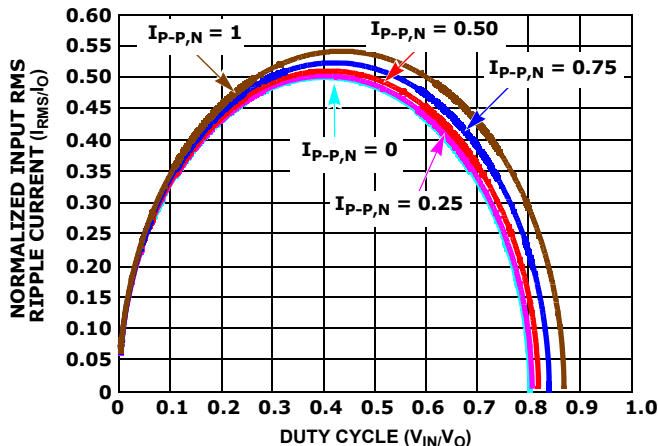

FIGURE 11. NORMALIZED RMS INPUT CURRENT FOR SINGLE PHASE CONVERTER

The normalized RMS current calculation is written as Equation 22:

$$I_{IN_RMS,N} = \sqrt{D \cdot (1-D) + \left(\frac{D}{12}\right) \cdot I_{PP,N}^2} \quad (EQ. 22)$$

Where:

- I_{MAX} is the maximum continuous I_{LOAD} of the converter
- $I_{PP,N}$ is the ratio of inductor peak-to-peak ripple current to I_{MAX}
- D is the duty cycle that is adjusted to take into account the efficiency of the converter which is written as:

$$D = \frac{V_O}{V_{IN} \cdot \eta} \quad (EQ. 23)$$

- where η is converter efficiency

Figure 12 provides the same input RMS current information for two-phase designs.

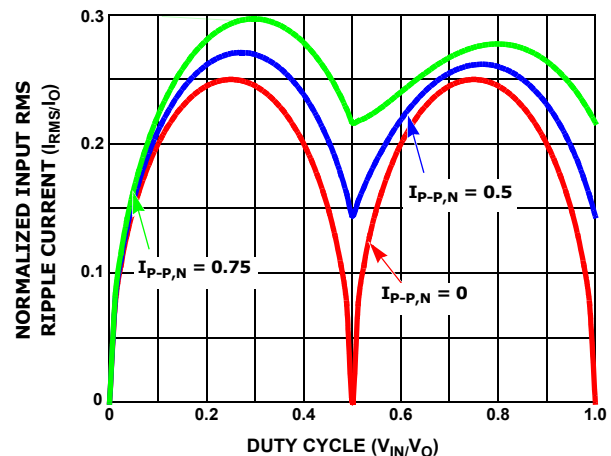

FIGURE 12. NORMALIZED RMS INPUT CURRENT FOR 2-PHASE CONVERTER

In addition to the bulk capacitance, some low ESL ceramic capacitance is recommended to decouple between the drain of the high-side MOSFET and the source of the low-side MOSFET.

MOSFET Selection and Considerations

The choice of MOSFETs depends on the current each MOSFET will be required to conduct, the switching frequency, the capability of the MOSFETs to dissipate heat, and the availability and nature of heat sinking and air flow.

Typically, a MOSFET cannot tolerate even brief excursions beyond their maximum drain to source voltage rating. The MOSFETs used in the power stage of the converter should have a maximum V_{DS} rating that exceeds the sum of the upper voltage tolerance of the input power source and the voltage spike that occurs when the MOSFETs switch.

There are several power MOSFETs readily available that are optimized for DC/DC converter applications. The

preferred high-side MOSFET emphasizes low gate charge so that the device spends the least amount of time dissipating power in the linear region. The preferred low-side MOSFET emphasizes low $r_{DS(ON)}$ when fully saturated to minimize conduction loss.

For the low-side (LS) MOSFET, the power loss can be assumed to be conductive only and is written as Equation 24:

$$P_{CON_LS} \approx I_{LOAD}^2 \cdot r_{DS(ON)_LS} \cdot (1 - D) \quad (EQ. 24)$$

For the high-side (HS) MOSFET, the its conduction loss is written as Equation 25:

$$P_{CON_HS} = I_{LOAD}^2 \cdot r_{DS(ON)_HS} \cdot D \quad (EQ. 25)$$

For the high-side MOSFET, the switching loss is written as Equation 26:

$$P_{SW_HS} = \frac{V_{IN} \cdot I_{VALLEY} \cdot t_{ON} \cdot f_{SW}}{2} + \frac{V_{IN} \cdot I_{PEAK} \cdot t_{OFF} \cdot f_{SW}}{2} \quad (EQ. 26)$$

Where:

- I_{VALLEY} is the difference of the DC component of the inductor current minus 1/2 of the inductor ripple current
- I_{PEAK} is the sum of the DC component of the inductor current plus 1/2 of the inductor ripple current
- t_{ON} is the time required to drive the device into saturation
- t_{OFF} is the time required to drive the device into cut-off

Selecting The Bootstrap Capacitor

All three integrated drivers feature an internal bootstrap schottky diode. Simply adding an external capacitor across the BOOT and PHASE pins completes the bootstrap circuit. The bootstrap function is also designed to prevent the bootstrap capacitor from overcharging due to the large negative swing at the PHASE node. This reduces voltage stress on the BOOT and PHASE pins.

The bootstrap capacitor must have a maximum voltage rating above $PVCC + 4V$ and its capacitance value is selected per Equation 27:

$$C_{BOOT} \geq \frac{Q_g}{\Delta V_{BOOT}} \quad (EQ. 27)$$

Where:

- Q_g is the total gate charge required to turn on the high-side MOSFET
- ΔV_{BOOT} , is the maximum allowed voltage decay across the boot capacitor each time the high-side MOSFET is switched on

As an example, suppose the high-side MOSFET has a total gate charge Q_g , of 25nC at $V_{GS} = 5V$, and a ΔV_{BOOT} of 200mV. The calculated bootstrap capacitance is 0.125 μF ; for a comfortable margin, select a capacitor

that is double the calculated capacitance. In this example, 0.22 μF will suffice. Use a low temperature-coefficient ceramic capacitor.

PCB Layout Considerations

Power and Signal Layers Placement on the PCB

As a general rule, power layers should be close together, either on the top or bottom of the board, with the weak analog or logic signal layers on the opposite side of the board. The ground-plane layer should be adjacent to the signal layer to provide shielding. The ground plane layer should have an island located under the IC, the compensation components, and the FSET components. The island should be connected to the rest of the ground plane layer at one point.

Component Placement

There are two sets of critical components in a DC/DC converter; the power components and the small signal components. The power components are the most critical because they switch large amount of energy. The small signal components connect to sensitive nodes or supply critical bypassing current and signal coupling.

The power components should be placed first and these include MOSFETs, input and output capacitors, and the inductor. It is important to have a symmetrical layout for each power train, preferably with the controller located equidistant from each power train. Symmetrical layout allows heat to be dissipated equally across all power trains. Keeping the distance between the power train and the control IC short helps keep the gate drive traces short. These drive signals include the LGATE, UGATE, PGND, PHASE and BOOT.

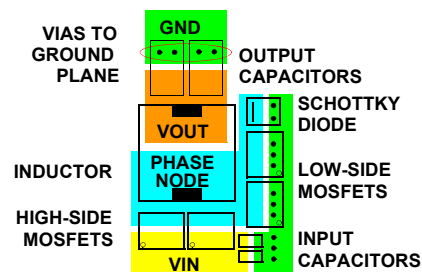

FIGURE 13. TYPICAL POWER COMPONENT PLACEMENT

When placing MOSFETs, try to keep the source of the upper MOSFETs and the drain of the lower MOSFETs as close as thermally possible (see Figure 13). Input high-frequency capacitors should be placed close to the drain of the upper MOSFETs and the source of the lower MOSFETs. Place the output inductor and output capacitors between the MOSFETs and the load. High-frequency output decoupling capacitors (ceramic) should be placed as close as possible to the decoupling target (microprocessor), making use of the shortest connection paths to any internal planes. Place the components in such a way that the area under the IC has

less noise traces with high dV/dt and di/dt , such as gate signals and phase node signals.

Signal Ground and Power Ground

The bottom of the ISL6265C QFN package is the signal ground (GND) terminal for analog and logic signals of the IC. Connect the GND pad of the ISL6265C to the island of ground plane under the top layer using several vias, for a robust thermal and electrical conduction path. Connect the input capacitors, the output capacitors, and the source of the lower MOSFETs to the power ground plane.

Routing and Connection Details

Specific pins (and the trace routing from them), require extra attention during the layout process. The following sub-sections outline concerns by pin name.

PGND PINS

This is the return path for the pull-down of the LGATE low-side MOSFET gate driver. Ideally, PGND should be connected to the source of the low-side MOSFET with a low-resistance, low-inductance path.

VIN PIN

The VIN pin should be connected close to the drain of the high-side MOSFET, using a low-resistance and low-inductance path.

VCC PIN

For best performance, place the decoupling capacitor very close to the VCC and GND pins.

PVCC PIN

For best performance, place the decoupling capacitor very close to the PVCC and respective PGND pins, preferably on the same side of the PCB as the ISL6265C IC.

ENABLE AND PGOOD PINS

These are logic signals that are referenced to the GND pin. Treat as a typical logic signal.

FB PINS

The input impedance of the FB pin is high, so place the voltage programming and loop compensation components close to the COMP, FB, and GND pins keeping the high impedance trace short.

FSET_NB PIN

This pin requires a quiet environment. The resistor R_{FSET} should be placed directly adjacent to this pin. Keep fast moving nodes away from this pin.

LGATE ROUTING

The LGATE trace has a signal going through it that is both high dV/dt and di/dt , with high peak charging and discharging current. Route this trace in parallel with the trace from the PGND pin. These two traces should be short, wide, and away from other traces. There should be no other weak signal traces in proximity with these traces on any layer.

BOOT AND PHASE ROUTING

The signals going through these traces are both high dv/dt and high di/dt , with high peak charging and discharging current. Route the UGATE and PHASE pins in parallel with short and wide traces. There should be no other weak signal traces in proximity with these traces on any layer.

Copper Size for the Phase Node

The parasitic capacitance and parasitic inductance of the phase node should be kept very low to minimize ringing. It is best to limit the size of the PHASE node copper in strict accordance with the current and thermal management of the application. An MLCC should be connected directly across the drain of the upper MOSFET and the source of the lower MOSFET to suppress the turn-off voltage.

Revision History

The revision history provided is for informational purposes only and is believed to be accurate, but not warranted. Please go to web to make sure you have the latest Rev.

DATE	REVISION	CHANGE
7/23/10	FN6976.1	Added "Related Literature*(see page 26)" on page 1. On page 3; corrected part marking in "Ordering Information" from ISL6265C HRTZ to 6265C HRTZ In "Thermal Information" on page 10, corrected Theta JC from 32 to 28 In "Electrical Specifications" table, corrected standard over temp note in common conditions of Spec table from "Boldface limits apply over the operating temperature range, -40°C to +85°C." to "Boldface limits apply over the operating temperature range, -10°C to +100°C." On "Overvoltage Threshold" on page 12; changed typical from 1.795V to 1.800V and maximum from 1.820V to 1.825V.
3/10/10	FN6976.0	Initial Release.

Products

Intersil Corporation is a leader in the design and manufacture of high-performance analog semiconductors. The Company's products address some of the industry's fastest growing markets, such as, flat panel displays, cell phones, handheld products, and notebooks. Intersil's product families address power management and analog signal processing functions. Go to www.intersil.com/products for a complete list of Intersil product families.

*For a complete listing of Applications, Related Documentation and Related Parts, please see the respective device information page on intersil.com: [ISL6265C](http://www.intersil.com/products)

To report errors or suggestions for this datasheet, please go to www.intersil.com/askourstaff

FITs are available from our website at <http://rel.intersil.com/reports/search.php>

For additional products, see www.intersil.com/product_tree

Intersil products are manufactured, assembled and tested utilizing ISO9000 quality systems as noted in the quality certifications found at www.intersil.com/design/quality

Intersil products are sold by description only. Intersil Corporation reserves the right to make changes in circuit design, software and/or specifications at any time without notice. Accordingly, the reader is cautioned to verify that data sheets are current before placing orders. Information furnished by Intersil is believed to be accurate and reliable. However, no responsibility is assumed by Intersil or its subsidiaries for its use; nor for any infringements of patents or other rights of third parties which may result from its use. No license is granted by implication or otherwise under any patent or patent rights of Intersil or its subsidiaries.

For information regarding Intersil Corporation and its products, see www.intersil.com

Package Outline Drawing

L48.6x6

48 LEAD THIN QUAD FLAT NO-LEAD PLASTIC PACKAGE

Rev 1, 4/07

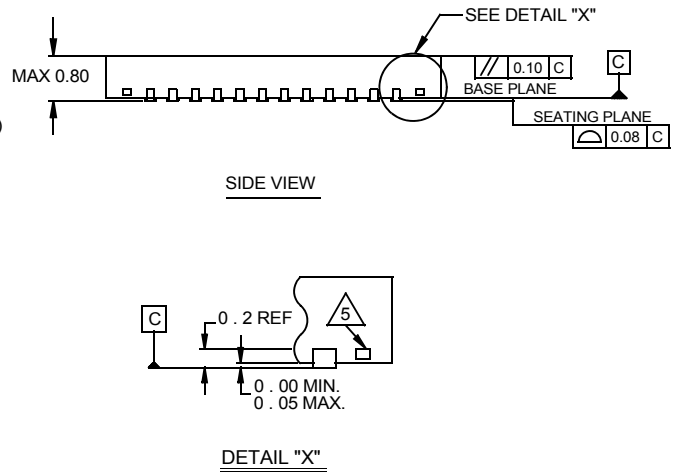
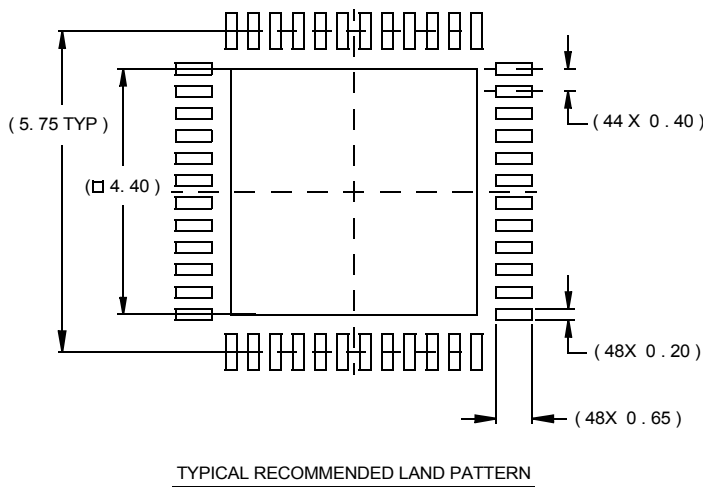
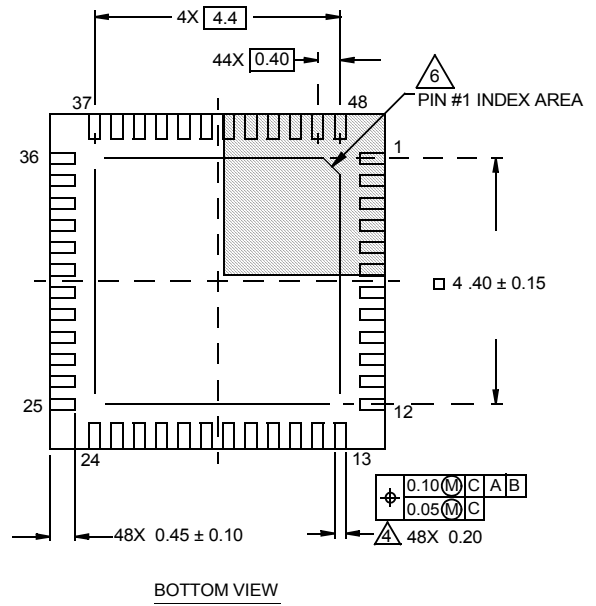
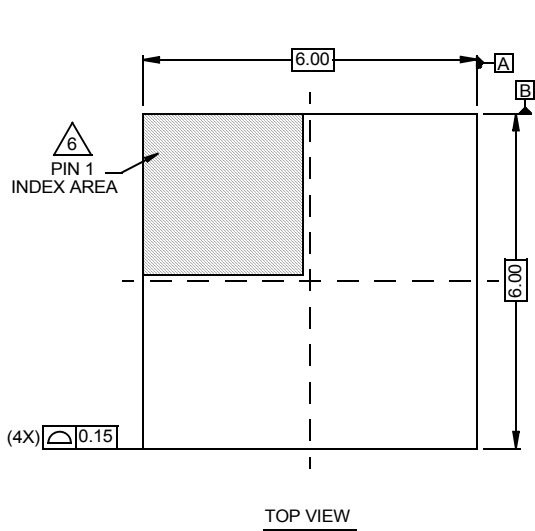

NOTES:

1. Dimensions are in millimeters.
Dimensions in () for Reference Only.
2. Dimensioning and tolerancing conform to AMSE Y14.5m-1994.
3. Unless otherwise specified, tolerance : Decimal ± 0.05
4. Dimension b applies to the metallized terminal and is measured between 0.15mm and 0.30mm from the terminal tip.
5. Tiebar shown (if present) is a non-functional feature.
6. The configuration of the pin #1 identifier is optional, but must be located within the zone indicated. The pin #1 identifier may be either a mold or mark feature.