

**PLEASE CHECK WWW.MOLEX.COM FOR LATEST PART INFORMATION**

**Part Number:** [0442626412](#)  
**Status:** **Active**  
**Description:** 5.33mm (.210") Pitch Crimp Terminal, Power Blade, Tin (Sn) Over Nickel (Ni), 14-16 AWG, Blade Length 13.08mm (.515")

**Documents:**

[Drawing \(PDF\)](#) [RoHS Certificate of Compliance \(PDF\)](#)

**General**

Product Family	Crimp Terminals
Series	<a href="#">44262</a>
Crimp Quality Equipment	Yes
Product Name	N/A

**Physical**

Durability (mating cycles max)	500
Gender	Male
Material - Metal	Copper
Material - Plating Mating	Tin
Packaging Type	Reel
Termination Interface: Style	Crimp or Compression
Wire Insulation Diameter	1.52-3.30mm (.060-.130")
Wire Size AWG	14, 16
Wire Size mm <sup>2</sup>	N/A

**Electrical**

Current - Maximum per Contact	20A
Voltage - Maximum	600V AC

**Material Info**

**Reference - Drawing Numbers**

Sales Drawing	SD-44262-026
---------------	--------------

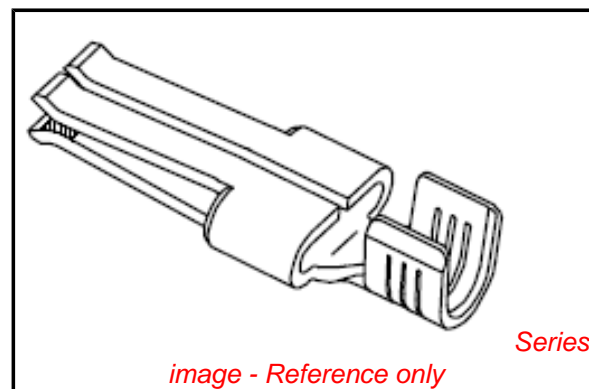

**EU RoHS**

**ELV and RoHS  
Compliant**  
**REACH SVHC  
Contains SVHC: No**  
**Halogen-Free  
Status  
Not Reviewed**

**China RoHS**



**Need more information on product  
environmental compliance?**

Email [productcompliance@molex.com](mailto:productcompliance@molex.com)  
 For a multiple part number RoHS Certificate of Compliance, [click here](#)

Please visit the [Contact Us](#) section for any non-product compliance questions.

**Search Parts in this Series**

[44262Series](#)

**Use With**

638326000 Crimp Applicator

**Application Tooling | FAQ**

*Tooling specifications and manuals are found by selecting the products below. Crimp Height Specifications are then contained in the Application Tooling Specification document.*

**Global**

Description	Product #
Hand Crimp Tool for 14-18 AWG Male and Female Power Contact Terminals	<a href="#">0638195500</a>
Mini-Mac™ Applicator	<a href="#">0638326100</a>

**PLEASE CHECK [WWW.MOLEX.COM](http://WWW.MOLEX.COM) FOR LATEST PART INFORMATION**

PART NUMBER	PLATING	RECOMMENDED WIRE SIZE	DIM 'A' BLADE LENGTH	DIM 'B' WIDTH	DIM 'C' HEIGHT	RECOMMENDED CRIMP APPLICATOR	PRODUCT STATUS
44262-6510	80-160μ INCHES TIN OVERALL OVER 50μ INCHES NICKEL OVERALL	8 AWG	10.03/.395	N/A	N/A	63832-6300	NOT TOOLED
44262-6511			11.56/.455				
44262-6512			13.08/.515				
44262-6520	30μ INCHES SELECT GOLD STRIPE OVER 50μ INCHES NICKEL OVERALL WITH 80-160μ INCHES SELECT TIN	(2) 12 AWG	10.03/.395	N/A	N/A	63832-6300	NOT TOOLED
44262-6521			11.56/.455				
44262-6522			13.08/.515				
44262-6310			10.03/.395				
44262-6311	80-160μ INCHES TIN OVERALL OVER 50μ INCHES NICKEL OVERALL	10-12 AWG	11.56/.455	N/A	N/A	63832-6000	NOT TOOLED
44262-6312			13.08/.515				
44262-6320			10.03/.395				
44262-6321	30μ INCHES SELECT GOLD STRIPE OVER 50μ INCHES NICKEL OVERALL WITH 80-160μ INCHES SELECT TIN	(2) 14 AWG	11.56/.455	5.33+-0.25 .210+-0.10	5.97+-0.50 .235+-0.020	63832-6000	TOOLED
44262-6322			13.08/.515				
44262-6410			10.03/.395				
44262-6411	80-160μ INCHES TIN OVERALL OVER 50μ INCHES NICKEL OVERALL	14-16 AWG	11.56/.455	N/A	N/A	63832-6100	TOOLED
44262-6412			13.08/.515				
44262-6420	30μ INCHES SELECT GOLD STRIPE OVER 50μ INCHES NICKEL OVERALL WITH 80-160μ INCHES SELECT TIN	(2) 16 AWG	10.03/.395	N/A	5.21+-0.50 .205+-0.020	63832-6100	TOOLED
44262-6421			11.56/.455				
44262-6422			13.08/.515				

- NOTES:
- MATERIAL: COPPER ALLOY .032 IN THICK
  - FINISH: PER MOLEX PLATING SPECIFICATION ES-88 - SEE CHART
  - SEE CHART FOR CRIMP APPLICATOR NUMBER
  - FOR CRIMP TOOLING CONTACT MOLEX OR VISIT THE MOLEX WEBSITE AT WWW.MOLEX.COM
  - STD PACKAGE SIZE: 2,500 PARTS/REEL
  - SEE PRODUCT SPECIFICATION: PS-44262-001 FOR MORE INFORMATION.
  - PARTS ARE RgHS COMPLIANT
  - THIS PART MATES WITH RECEPTACLE (FEMALE) POWER CONTACT 44262-43\*\* (SEE SD-44262-100)
  - FOR CRIMP SET UP INFORMATION SEE MOLEX APPLICATION DOCUMENT:
    - 8 AWG - ATS-638326300
    - 10/12 AWG - ATS-638326000
    - 14/16 AWG - ATS-638326100

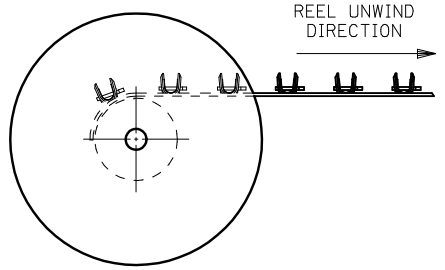
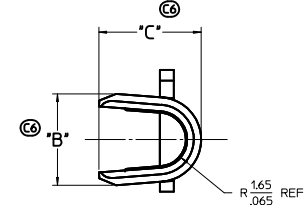
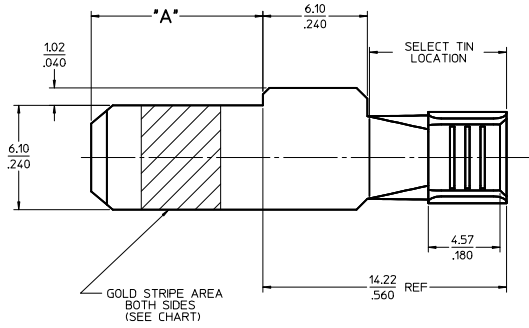
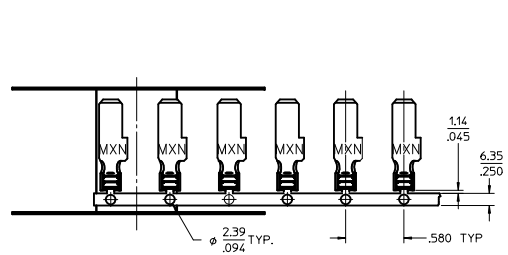
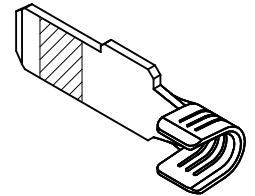

Ⓢ

Ⓢ

Ⓢ

<b>REV DIMS &amp; CHART</b> IEC NO: 2010/01/06 CHYK: APPR:	QUALITY SYMBOLS	GENERAL TOLERANCES (UNLESS SPECIFIED)	DIMENSION STYLE	SCALE	DESIGN UNITS	THIRD ANGLE PROJECTION
	▽=0	4 PLACES ±.010 ±.010	MM/IN	5:1	INCH	Ⓢ
	▽=0	3 PLACES ±.025 ±.010				
	▽=0	2 PLACES ±0.25 ±.010				
		1 PLACE ±0.25 ±.010				
		ANGULAR ±1/2°				
		DRAFT WHERE APPLICABLE MUST REMAIN WITHIN DIMENSIONS				
			MATERIAL NO.	DOCUMENT NO.		
			SEE CHART	SD-44262-026		

TERMINAL - BLADE POWER TERMINAL

MOLEX INCORPORATED

SD-44262-026

1 OF 1