



Intel® Modular Server System MFSYS25/MFSYS35

Technical Product Specification

Intel order number E15155-006

Revision 1.3

November, 2008

Enterprise Platforms and Services Division

Revision History

Date	Revision Number	Modifications
July, 2007	0.88	Initial release.
September, 2007	1.0	Updated.
February, 2008	1.1	Updated.
June, 2008	1.2	Updated Power Budget of Hardware Components, Table 5. Added 3.5-inch drive bay information for the Intel® Modular Server System MFSYS35.
November, 2008	1.3	Updated System Details, power and heat specifications

Disclaimers

Information in this document is provided in connection with Intel® products. No license, express or implied, by estoppel or otherwise, to any intellectual property rights is granted by this document. Except as provided in Intel's Terms and Conditions of Sale for such products, Intel assumes no liability whatsoever, and Intel disclaims any express or implied warranty, relating to sale and/or use of Intel products including liability or warranties relating to fitness for a particular purpose, merchantability, or infringement of any patent, copyright or other intellectual property right. Intel products are not intended for use in medical, life saving, or life sustaining applications. Intel may make changes to specifications and product descriptions at any time, without notice.

Designers must not rely on the absence or characteristics of any features or instructions marked “reserved” inches or “undefined” Intel reserves these for future definition and shall have no responsibility whatsoever for conflicts or incompatibilities arising from future changes to them.

The Intel® Modular Server System MFSYS25/MFSYS35 may contain design defects or errors known as errata, which may cause the product to deviate from published specifications. Current characterized errata are available on request.

Intel Corporation server baseboards contain a number of high-density VLSI and power delivery components that need adequate airflow to cool. Intel's own chassis are designed and tested to meet the intended thermal requirements of these components when the fully integrated system is used together. It is the responsibility of the system integrator that chooses not to use Intel developed server building blocks to consult vendor datasheets and operating parameters to determine the amount of airflow required for their specific application and environmental conditions. Intel Corporation cannot be held responsible if components fail or the server board does not operate correctly when used outside any of their published operating or non-operating limits.

Intel and Xeon are trademarks or registered trademarks of Intel Corporation.

*Other brands and names may be claimed as the property of others. Copyright © Intel Corporation 2007-2008

Table of Contents

1. Product Overview	1
2. System Overview	2
2.1 Introduction	2
2.2 External Chassis Features – Front	5
2.2.1 Compute Module	6
2.2.2 Storage Enclosure	6
2.2.3 I/O Cooling Module	6
2.3 External Chassis Features – Rear	7
2.3.1 Power Supply Module	7
2.3.2 I/O Slots	7
2.3.3 Chassis Management Module	8
2.3.4 Main Cooling Module	8
2.4 Internal Chassis Features	8
2.4.1 Midplane Board.....	10
2.4.2 Storage Interposer Board	11
2.5 Mounting and Service Features	11
2.5.1 Chassis	11
2.5.2 Rails	11
2.6 Server Management	11
2.6.1 Chassis Management Module	12
2.6.2 Compute Module Management	12
2.7 Reliability, Availability, Serviceability, Usability, Manageability (RASUM)	13
3. System Details	14
3.1 Specifications.....	14
3.1.1 Environmental Specifications Summary	14
3.1.2 Physical Specifications Summary	14
3.1.3 Power Specifications Summary	15
3.2 Chassis	16
3.3 Midplane Board.....	19
3.3.1 Mechanical Outline	19
3.3.2 3D Renderings.....	20
3.4 Compute Module	21
3.4.1 Introduction	21
3.4.2 Drawings.....	22
3.5 Chassis Management Module	22
3.5.1 Introduction	22
3.5.2 Mechanical Outline	23
3.5.3 Block Diagram	24

3.5.4	Drawings.....	24
3.5.5	Architectural Overview	25
3.6	Ethernet Switch Module	26
3.6.1	Introduction	26
3.6.2	Mechanical Outline	26
3.6.3	Block Diagram	27
3.6.4	Architectural Overview	27
3.7	Storage Controller Module	28
3.7.1	Storage Subsystem Introduction.....	28
3.7.2	Mechanical Outline	28
3.7.3	Storage Controller Module View	29
3.7.4	Architectural Overview	29
3.8	Power Supply Module	30
3.9	Jumpers and LEDs	31
4.	Product Regulatory Requirements	32
4.1	Product Regulatory Compliance	32
4.1.1	Product Safety Compliance	32
4.1.2	Product EMC Compliance - Class A Compliance	32
4.1.3	Product Ecology Compliance.....	33
4.1.4	Certifications / Registrations / Declarations	33
4.2	Product Regulatory Compliance Markings	33
4.3	Regulated Specified Components	38
4.4	Electromagnetic Compatibility Notices	39
4.4.1	FCC Verification Statement (USA)	39
4.4.2	ICES-003 (Canada)	40
4.4.3	Europe (CE Declaration of Conformity)	40
4.4.4	VCCI (Japan)	41
4.4.5	BSMI (Taiwan)	41
	Glossary.....	43
	Reference Documents	46

List of Figures

Figure 1. Intel® Modular Server System MFSYS25 Wiring Diagram.....	3
Figure 2. Intel® Modular Server System MFSYS35 Wiring Diagram.....	4
Figure 3. Front View of Server Platform.....	5
Figure 4. Rear View of Server Platform	7
Figure 5. View of Intel® Modular Server System MFSYS25 System Board Connectivity.....	9
Figure 6. View of Intel® Modular Server System MFSYS35 System Board Connectivity.....	10
Figure 7. Server Management Connectivity.....	12
Figure 8. Front View of Empty Intel® Modular Server System MFSYS25	16
Figure 9. Front View of Empty Intel® Modular Server System MFSYS35	17
Figure 10. Rear View of Empty Intel® Modular Server System MFSYS25.....	18
Figure 11. Rear View of Empty Intel® Modular Server System MFSYS35.....	18
Figure 12. Midplane Board Mechanical Outline (Front View)	19
Figure 13. Front View of Midplane Board	20
Figure 14. Rear View of Midplane Board	21
Figure 15. Front View of Compute Module	22
Figure 16. Chassis Management Module Board Outline (Top View)	23
Figure 17. Chassis Management Module Block Diagram.....	24
Figure 18. Front View of Chassis Management Module	25
Figure 19. Ethernet Switch Module Mechanical Outline (Top View)	26
Figure 20. Ethernet Switch Module Block Diagram	27
Figure 21. Mechanical Outline of Storage Controller Module Board.....	28
Figure 22. Front View of Storage Controller Module.....	29

List of Tables

Table 1. Server Platform Feature List	2
Table 2. Environmental Specifications Summary	14
Table 3. Physical Specifications of Chassis.....	14
Table 4. Physical Dimensions of Hardware Components.....	15
Table 5. Power Budget of Hardware Components	15
Table 6. Power and Heat Dissipation Specifications of Chassis.....	15

1. Product Overview

This product specification details the features of the Intel® Modular Server System MFSYS25/MFSYS35. This product is designed to serve the small to medium business environment. Primary design considerations include ease of use, reliability, low cost, modularity, and remote management.

The Intel® Modular Server System MFSYS25/MFSYS35 supports up to six dual-processor compute modules, or a total of 12 Multi-Core Intel® Xeon® 5000 sequence processors. The chassis also incorporates features that clearly distinguish it as an easy-to-use and highly available server platform. Building on previous server platforms, the Intel® Modular Server System MFSYS25/MFSYS35 includes redundant storage and networking, in addition to the enterprise features of hot-swap power, cooling, and hard disk drives. Advanced server management features remotely monitor and manage the server.

This document is organized into four sections:

- **Section 1: Product Overview**
This section provides an overview of the product.
- **Section 2: System Overview**
This section provides an overview of the system hardware.
- **Section 3: System Details**
This section provides details of the various hardware components specific to the server platform.
- **Section 4: Product Regulatory Requirements**
This section describes system compliance to regulatory specifications.

2. System Overview

This section provides an overview of the features of the Intel® Modular Server System MFSYS25/MFSYS35.

2.1 Introduction

The platform supports six compute modules providing sockets for up to 12 Multi-Core Intel® Xeon® processors 5000 sequence, up to 192 GB of memory (using 4-GB DIMMs), up to fourteen hot-swap 2.5-inch SAS hard disk drives in the Intel® Modular Server System MFSYS25 or up to six hot-swap 3.5-inch SAS/SATA hard disk drives in the Intel® Modular Server System MFSYS35, an integrated server management module, redundant Ethernet switches and redundant storage controllers. The server ships configured for rack mounting, but may be mounted in a pedestal configuration.

The following table lists and briefly describes the features of the Intel® Modular Server System MFSYS25/MFSYS35.

Table 1. Server Platform Feature List

Feature	Description
Compact, high-density system	Rack-mount server with a height of 6U (10.5 inches) and a depth of 28 inches (706 mm)
Configuration flexibility	Shared storage hard drive bay supporting up to fourteen (14) 2.5-inch SAS hard drives in the Intel® Modular Server System MFSYS25 and up to six (6) 3.5-inch SAS/SATA hard drives in the Intel® Modular Server System MFSYS35. Up to six (6) compute modules Optional secondary Ethernet switch module Optional secondary storage controller
Serviceability	Tool-less design features Front access to optional hot-swap hard disk drives Rear access to I/O slots, cooling, and hot-swap power supplies Status and fault indicator LEDs Front viewable compute module ID LEDs Color-coded parts to identify hot-swap and non-hot-swap serviceable components
Availability	Four 1000-W power supplies in a redundant (3+1) configuration with separate power cords Up to six compute modules Redundant networking and storage Redundant cooling
Manageability	Remote management Extensive system sensors and monitoring Remote diagnostics support via serial and LAN ports Web management console KVM console redirection The front of each individual compute module provides video, USB, a power button, and status LEDs that allow local monitoring and managing of the individual compute module.

Feature	Description
Cooling	<p>The cooling subsystem consists of three cooling zones</p> <ul style="list-style-type: none"> I/O module cooling Hard drives and power supplies Compute modules <p>Each cooling zone contains dedicated hot-swap fan modules. Each fan module contains a status LED to indicate a fan failure. The front- and rear-accessible fan modules connect directly to the system midplane board.</p>
Easy to use	<p>Full system management via Web browser Configuration wizards assist in setup of storage and network</p>

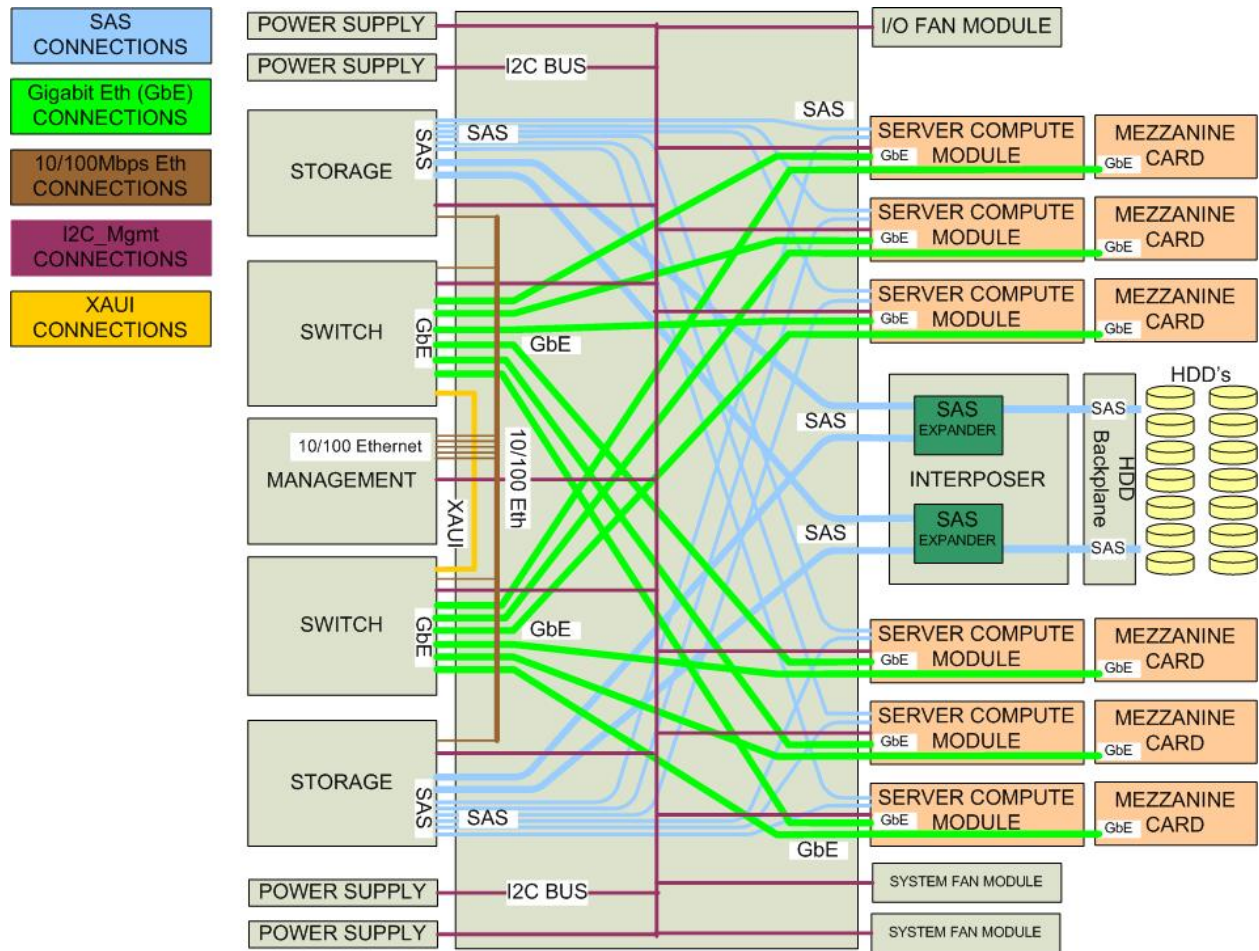

Figure 1. Intel® Modular Server System MFSYS25 Wiring Diagram

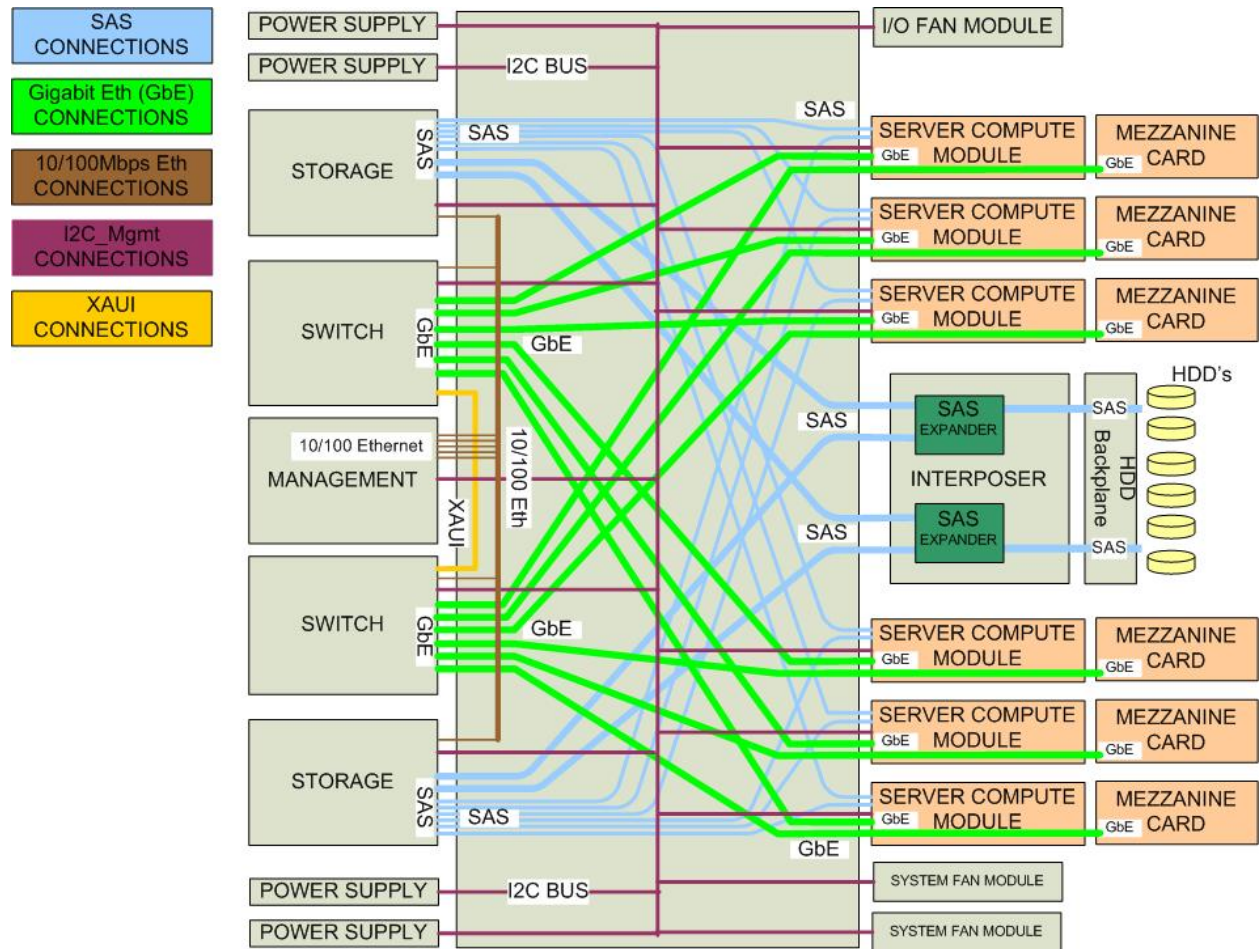
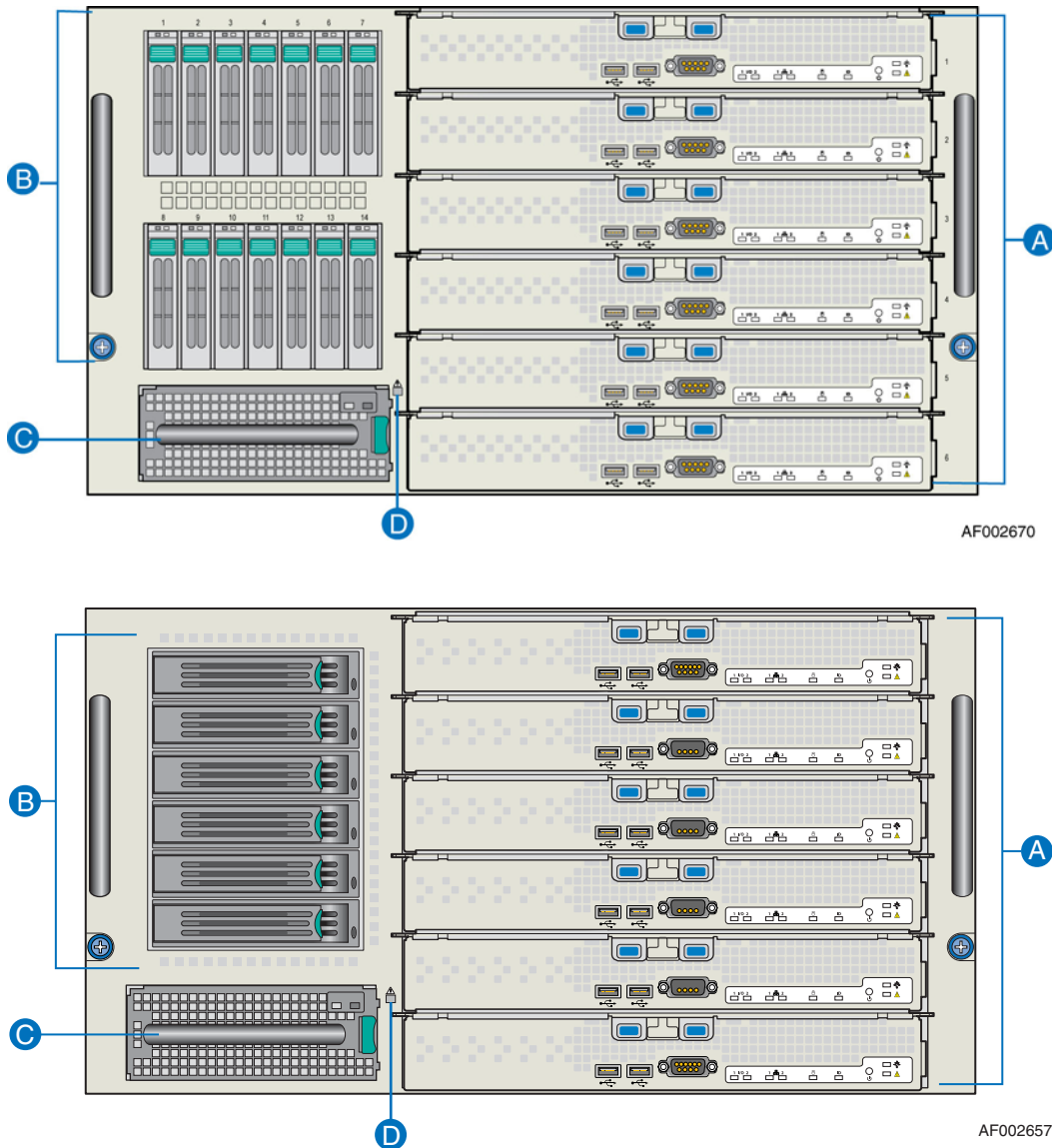

Figure 2. Intel® Modular Server System MFSYS35 Wiring Diagram

2.2 External Chassis Features – Front

Figure 3 shows the front view of the platform with all modules populated.



AF002670

AF002657

Item	Description
A	Compute modules (six)
B	Storage enclosure: 14 hot-swap 2.5-inch SAS hard disk drives – Intel® Modular Server System MFSYS25 only 6 hot-swap 3.5-inch SAS/SATA hard disk drives – Intel® Modular Server System MFSYS35 only
C	I/O cooling module
D	System Fault LED (amber)

Figure 3. Front View of Server Platform

2.2.1 Compute Module

The Intel® Modular Server System MFSYS25/MFSYS35 supports up to six compute modules. Each of these general-purpose servers provides the following minimum features:

- Processor(s)
- Memory
- Integrated Baseboard management controller
- Network interface

Each server connects to the chassis management module, storage controllers and switch modules via the midplane board. The midplane also distributes the 12V power from the power supplies to the compute modules. The servers connect to the shared storage (14 SAS drives in the Intel® Modular Server System MFSYS25 and 6 SAS/SATA drives in the Intel® Modular Server System MFSYS35) via the storage controller(s) in the rear of the chassis.

See the individual Intel® Compute Module *Technical Product Specification* for model-specific information about your compute module(s).

2.2.2 Storage Enclosure

The Intel® Modular Server System MFSYS25/MFSYS35 supports an optional hard disk drive storage enclosure and has the following minimum features:

- Bays for 14 hot-swap 2.5-inch SAS hard disk drives in the Intel® Modular Server System MFSYS25 and six (6) 3.5-inch SAS/SATA hard drives in the Intel® Modular Server System MFSYS35
- At least one storage controller in an I/O slot

Because hard disk drives have different cooling, power, and vibration characteristics, Intel validates specific hard disk drive types in the platforms. See the *Intel® Modular Server System MFSYS25/MFSYS35 Tested Hardware and Operating System List* for a list of qualified drives.

2.2.3 I/O Cooling Module

The I/O cooling module consists of six fans that operate in a (3 + 3) cooling redundancy in a hot-swap module with power and failure indicators. These fans provide cooling for all I/O modules. This module is accessible from the front of the system even though it cools the I/O modules in the rear of the system.

2.3 External Chassis Features – Rear

The following figure shows the rear view of the platform with all modules populated.

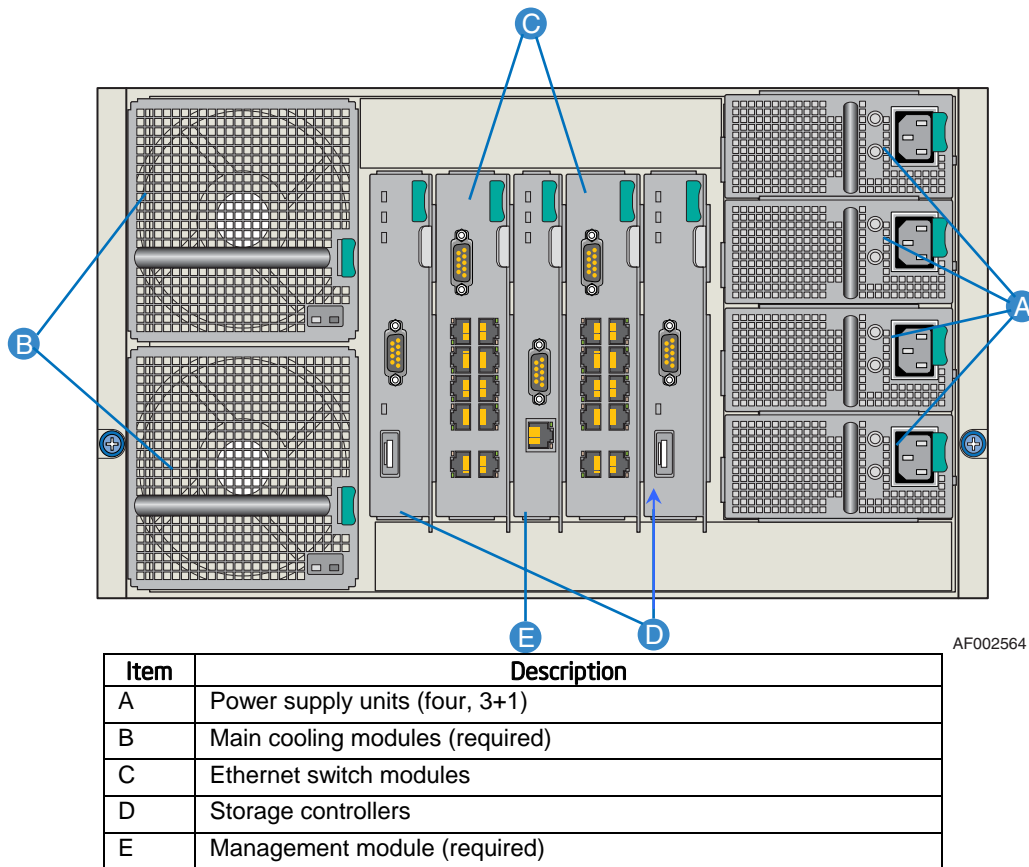

Figure 4. Rear View of Server Platform

2.3.1 Power Supply Module

Four hot-swap power supply modules are installed in the right rear of the chassis. Each supply has its own AC input power connector and is rated at 1000 W over an input range of 100-240 VAC. Each power supply includes two fans that provide cooling for optional hot-swap disk drives.

See Section 3.8 for more details on the power supply module.

2.3.2 I/O Slots

The middle-rear of the chassis can accommodate up to four expansion modules. See the following sections for a description of the two I/O modules currently offered.

2.3.2.1 Ethernet Switch Module

The chassis can accommodate up to two hot-swap Ethernet switch modules. Each switch has ten uplink ports on the rear panel in addition to two ports routed to each compute module. One switch module is the minimum configuration for external networking, with a second switch module allowing network redundancy.

See Section 3.6 for a description of this module.

2.3.2.2 Storage Controller Module

The chassis can accommodate up to two hot-swap storage controller modules to support the external hard disks in the front storage enclosure. One storage controller is the minimum configuration, with a second storage controller allowing storage controller redundancy. Storage controller failures are automatically detected and hard drive access is maintained through the operational storage controller.

See Section 3.7 for a description of this system.

2.3.3 Chassis Management Module

The chassis management module, installed in the middle-rear of the chassis amid the four I/O slots, provides an Internet browser interface that allows for configuration and management of the entire Intel® Modular Server System MFSYS25/MFSYS35. This module is not redundant, but the system continues to operate normally should this module fail although any changes to the system configuration cannot be made until the failed chassis management module is replaced.

See Section 3.5 for a description of this module.

2.3.4 Main Cooling Module

Two hot-swap cooling modules are installed on the left rear of the chassis. Each cooling module contains two redundant fans that operate in a (1+1) cooling redundancy. Cooling module 1 cools compute modules 1-3; cooling module 2 cools compute modules 4-6.

2.4 Internal Chassis Features

The following figures provide an internal view of how the Intel® Modular Server System MFSYS25/MFSYS35 system boards are connected.

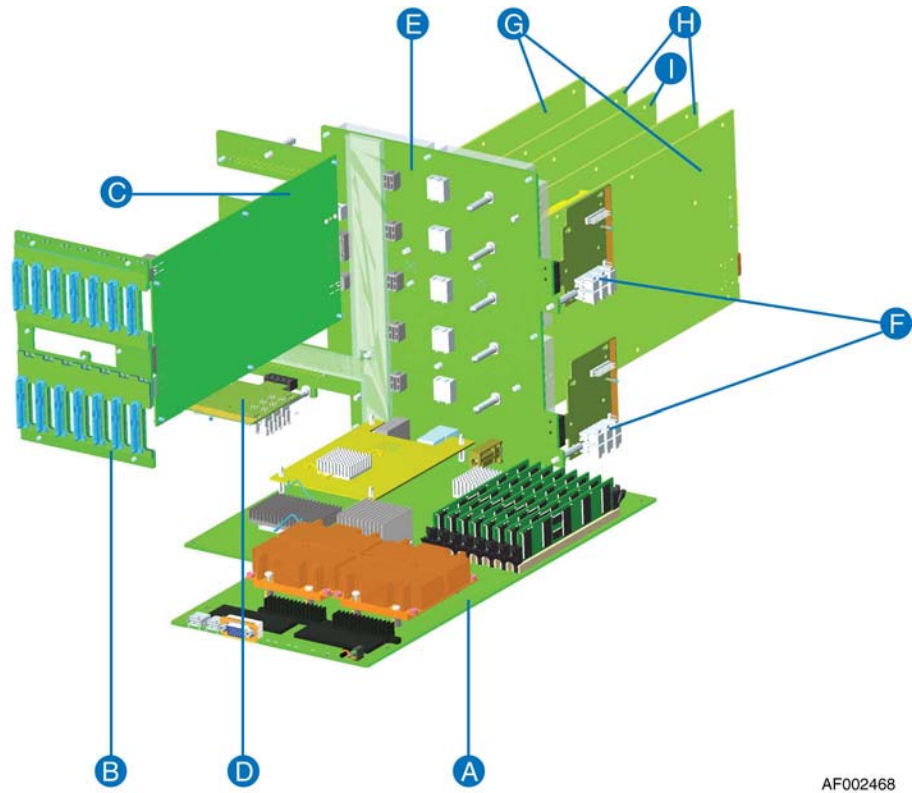

AF002468

Item	Description
A	Server board
B	14-drive backplane
C	Interposer board (connects drive backplane to midplane)
D	I/O fan controller
E	Midplane board
F	Compute module fan controllers
G	Storage controller boards
H	Switch module boards
I	Chassis management module board

Figure 5. View of Intel® Modular Server System MFSYS25 System Board Connectivity

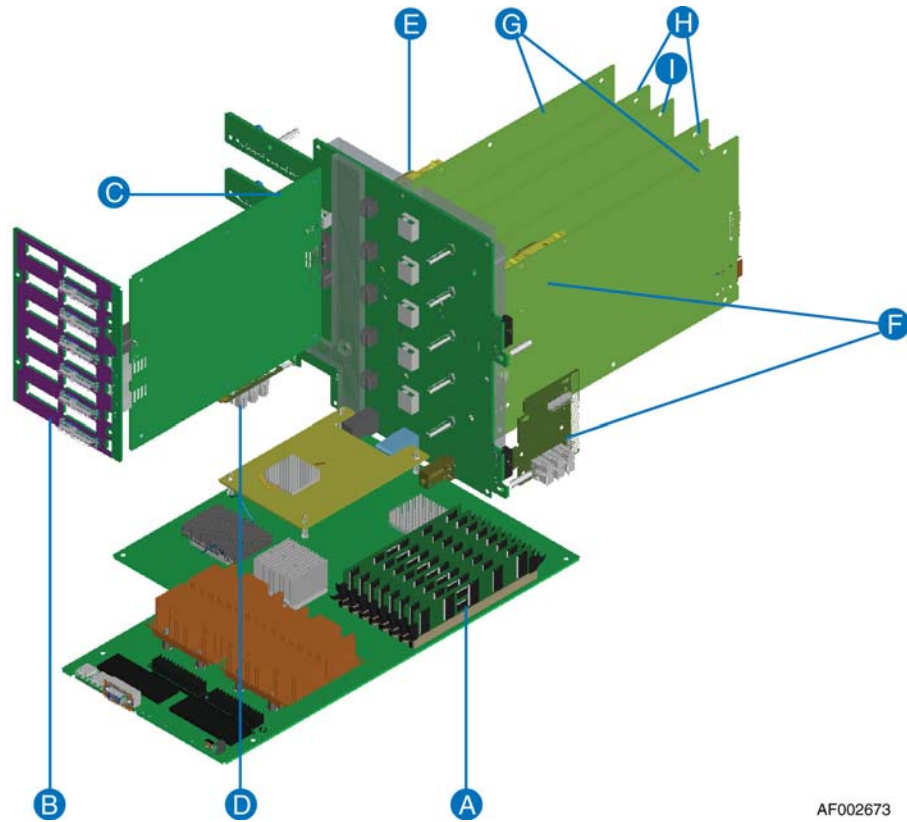

AF002673

Item	Description
A	Server board
B	6-drive backplane
C	Interposer board (connects drive backplane to midplane)
D	I/O fan controller
E	Midplane board
F	Compute module fan controllers
G	Storage controller boards
H	Switch module boards
I	Chassis management module board

Figure 6. View of Intel® Modular Server System MFSYS35 System Board Connectivity

2.4.1 Midplane Board

The midplane board mounts vertically in the middle of the system and provides power and I/O signaling, both high-speed and low-speed, to all chassis subassemblies and options. This board is considered to be a part of the chassis and cannot be replaced. For this reason, there are no active components on this board.

2.4.2 Storage Interposer Board

The interposer board mounts vertically in the front left of the system and connects the midplane to the hot-swap backplane in the storage enclosure. Each compute module connects to the storage controller with a non-RAID SAS controller, with the storage controller providing the RAID functionality.

2.5 Mounting and Service Features

2.5.1 Chassis

The platform utilizes a standard 19-inch EIA chassis, 6U high by 28 inches deep. The chassis can be rack-mounted or used as a pedestal system. Rack mounting the platform requires a space of 6U high by 19 inches wide by 34 inches deep, with additional six inches required for cable management. When used in a rack, the chassis may be mounted with an optional rail kit. Pedestal operation requires the installation of six rubber feet to the bottom of the chassis.

The 6U height is defined by standard EIA rack units, where 1U equals 1.75 inches. The 28-inch depth is measured from the front mounting flange to the back of the I/O slots. This measurement does not include cables or the bezel.

2.5.2 Rails

The platform accommodates rails to mount the chassis into a standard 19-inch rack. The Intel® Modular Server System MFSYS25/MFSYS35 uses fixed rails. All customer-accessible components provide either front or rear access. The rails attach to the rack using a tool-less mechanism. The system rests on the shelves of the rails and attaches to the rack using the integrated thumbscrews on the front flanges of the system. No loose hardware is needed.

2.6 Server Management

The management of all components in the system can be done through the chassis management module. This module provides a browser-based management interface that allows the configuration and management of all modules. As part of the compute module manageability, the chassis management module provides remote access (such as connectivity via Ethernet) to Keyboard-VDU-Mouse (KVM), USB media and serial console.

The management subsystem conforms to the *IPMI v2.0 Specification* for communication within the chassis (such as between the chassis management module and other system components). SNMP is supported by the chassis management module for external system management.

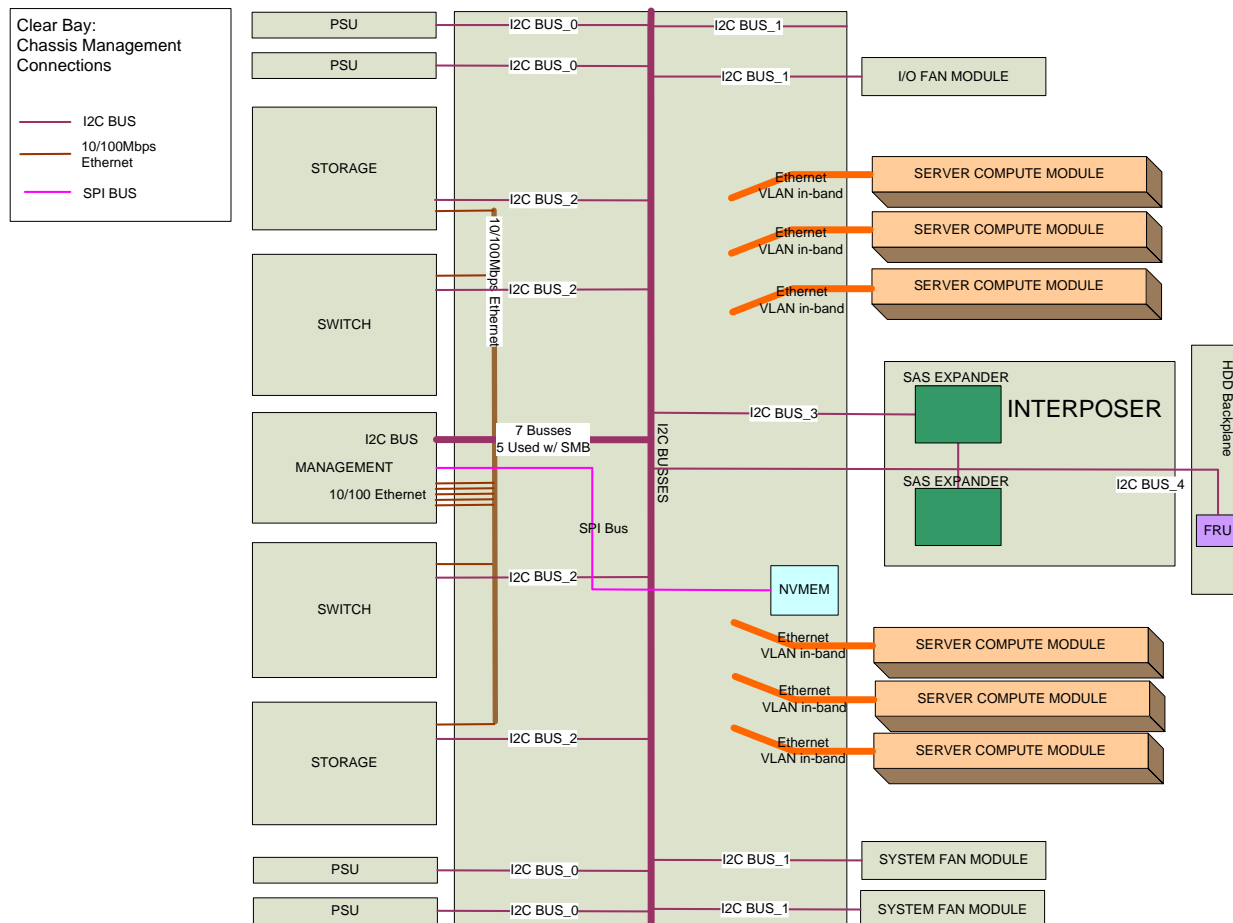

Figure 7. Server Management Connectivity

2.6.1 Chassis Management Module

The main controller in the chassis management module is an Intel® XScale IXP425 microcontroller that runs Linux to provide a robust operating environment. The service processor provides IPMI communication within the system in addition to the user interface used to manage the system over Ethernet.

See Section 3.5 for a description of this board.

2.6.2 Compute Module Management

Each compute module contains an Integrated Baseboard Management Controller (BMC) that is responsible for all management local to the module, including power control, reset, sensor reading, remote KVM, remote media and remote serial console. The Integrated BMC also gathers events to be stored in the server event log. However, the compute module's Integrated BMC is managed by the chassis management module and must communicate with the chassis management before providing any of these management features.

This architecture allows the chassis management module to control the security of all components in the system.

2.7 Reliability, Availability, Serviceability, Usability, Manageability (RASUM)

The platform supports the following reliability, availability, serviceability, usability and manageability (RASUM) features:

- Reliability features
 - Voltage and temperature monitoring throughout the system
- Availability features
 - Hot-plug compute modules
 - Hot-spare compute modules
 - Redundant hot-swap power supply modules
 - Redundant hot-swap system fans
 - Hot-swap SAS hard drives
 - Optional teaming and failover Ethernet ports
- Serviceability features
 - Tool-less installation and removal of major sub-assemblies
 - Color-coded parts to identify serviceable components
 - Green: To identify hot-swap or hot-plug components
 - Blue: To identify non-hot-swap components
 - Compute module ID buttons and LEDs
 - LED indicators for system health, configured options, and activity
- Usability features
 - Tool-less design features
 - External access to hot-swap hard disk drives, power supplies, LEDs and switches
 - Front viewable compute module ID LEDs
 - Color-coded parts to identify hot-swap and non-hot-swap serviceable components
- Manageability features
 - Remote management via serial and LAN
 - IPMI 2.0 compliance
 - Remote management via KVM and dedicated LAN

All subsystems are connected by a server management I²C bus to satisfy the system RASUM requirements.

3. System Details

3.1 Specifications

3.1.1 Environmental Specifications Summary

The following table describes the environmental specifications of the Intel® Modular Server System MFSYS25/MFSYS35

Table 2. Environmental Specifications Summary

Environment	Specification	
Temperature operating	10°C to 35°C	50°F to 95°F
Temperature non-operating	-40°C to 70°C	-40°F to 158°F
Altitude	-30 to 1,500 m	-100 to 5,000 ft
Humidity non-operating	95%, non-condensing at temperatures of 25°C (77°F) to 30°C (86°F)	
Vibration non-operating	2.2 g, 10 minutes per axis on each of the three axes	
Shock operating	Half-sine 2 G, 11 ms pulse, 100 pulses in each direction, on each of the three axes	
Shock non-operating	Trapezoidal, 25 G, two drops on each of six faces ΔV : 175 inches/sec on bottom face drop, 90 inches/sec on other 5 faces	
Safety	UL60 950, CSA60 950, AS/NZS 3562, GB4943-1995, EN60 950 <i>and</i> 73/23/EEC, IEC 60 950, EMKO-TSE (74-SEC) 207/94, GOST-R 50377-92	
Emissions	Certified to FCC Class A; tested to CISPR 22 Class A, EN 55022 Class A <i>and</i> 89/336/EEC, VCCI Class A, AS/NZS 3548 Class A, ICES-003 Class A, GB9254-1998, MIC Notice 1997-42 Class A, GOST-R 29216-91 Class A, BSMI CNS13438	
Immunity	Verified to comply with EN55024, CISPR 24, GB9254-1998, MIC Notice 1997-41, GOST-R 50628-95	
Electrostatic discharge	Tested to ESD levels up to 15 kilovolts (kV) air discharge and up to 8 kV contact discharge without physical damage	
Acoustic	Sound power: < 7.0 BA at ambient temperature < 23° C measured using the Dome Method GOST MsanPiN 001-96	

3.1.2 Physical Specifications Summary

The following table describes the physical specifications of the Intel® Modular Server System MFSYS25/MFSYS35.

Table 3. Physical Specifications of Chassis

Specification	Value	
Height – 6U	10.3 inches	261.4 mm
Width	17.5 inches	444.4 mm
Depth	28.4 inches	720.2 mm
Weight (full configuration)	187 lbs	85 kg

The following table describes the physical dimensions of the Intel® Modular Server System MFSYS25/MFSYS35 and all components.

Table 4. Physical Dimensions of Hardware Components

Module	Height	Width	Length
Chassis	261.4 mm	444.4 mm	720.2 mm
Compute module	41.7 mm	279.4 mm	420.3 mm
CMM	25.0 mm	167.6 mm	295.9 mm
I/O	38.0 mm	167.6 mm	295.9 mm
Storage	32.0 mm	167.6 mm	295.9 mm
Hard drive bay	182.5 mm	130.2 mm	419.1 mm
Power supply module	53.3 mm	115 mm	286.3 mm
Main cooling module	126.6 mm	126.0 mm	291.9 mm
I/O cooling module	49.4 mm	132.6 mm	416.9 mm

3.1.3 Power Specifications Summary

The following table provides a summary of the 12V power budget for all modules in the Intel® Modular Server System MFSYS25/MFSYS35.

Table 5. Power Budget of Hardware Components

Subsystem	12V Budget
Compute module	406 W
Mezzanine card	5 W
Chassis management module	5 W
I/O Switch	40 W
Storage module	48 W
2.5/3.5-inch SAS drives	140 W
Chassis	188 W
Power supply blank	26 W
System Total	
Power subsystem spec	3000 W

The following table provides a summary of the power and heat dissipation specifications for the Intel® Modular Server System MFSYS25/MFSYS35.

Table 6. Power and Heat Dissipation Specifications of Chassis

Power Supply Input	1240 W
Power Supply Output	1050 W
System Power Input	3720 W
System Power Output	3150 W
System Power	100 V – 127 V, 200 V – 240 V
System Heat Dissipation	3720 W (12,701 BTUH) maximum
System Heat Dissipation	428 W (1461 BTUH) minimum

3.2 Chassis

The Intel® Modular Server System MFSYS25/MFSYS35 design accommodates multiple generations of compute modules, I/O modules, and storage controllers without the need to upgrade or modify the chassis or the midplane board. This strategy allows the system to be in use for many years with only the occasional upgrade of front and/or rear components as new technologies become available.

The following two figures show the front view of an empty Intel® Modular Server System MFSYS25/MFSYS35. Note that the hard drive bay is installed and the hard drive backplane is visible on the left side of the chassis. The midplane board is also installed and is visible through the empty compute module bay area.



Figure 8. Front View of Empty Intel® Modular Server System MFSYS25

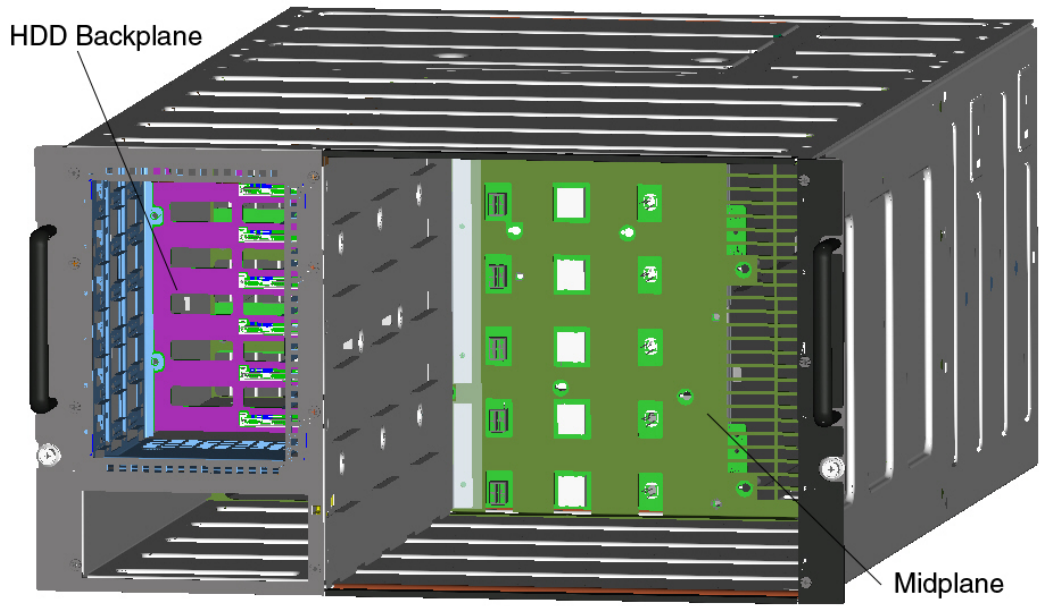

Figure 9. Front View of Empty Intel® Modular Server System MFSYS35

The following two figures show the rear view of an empty Intel® Modular Server System MFSYS25/MFSYS35. The midplane is installed and is visible through the empty I/O and power supply module areas.

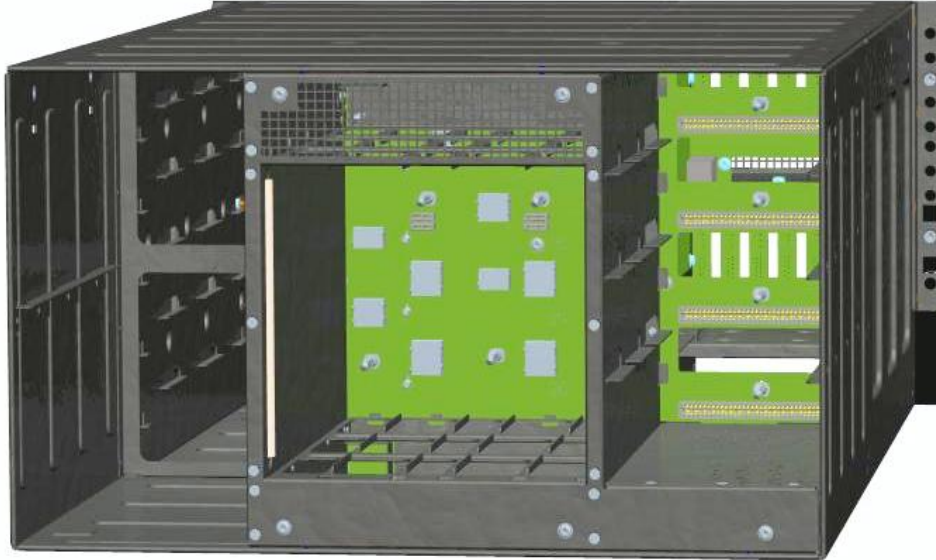

Figure 10. Rear View of Empty Intel® Modular Server System MFSYS25

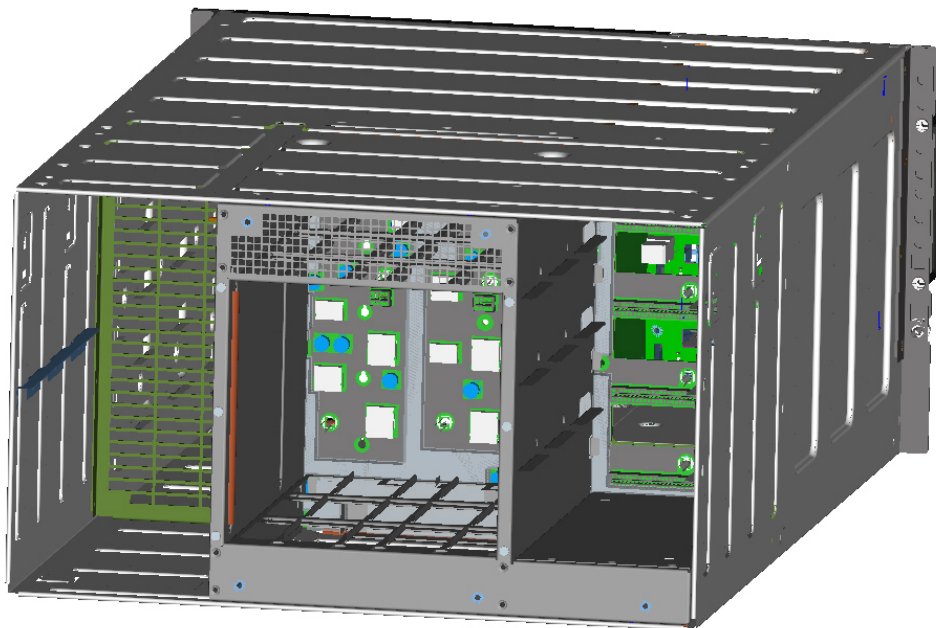

Figure 11. Rear View of Empty Intel® Modular Server System MFSYS35

3.3 Midplane Board

This section describes the platform's midplane board. The midplane is the central board that connects to all removable modules. The midplane board, like the chassis, is designed to accommodate multiple generations of compute modules, I/O modules and storage controllers without the need to upgrade or modify the board. The connectors and electrical routing of the midplane board have been designed to support future, higher speed technologies up to 10 Gb/s.

3.3.1 Mechanical Outline

The following figure shows the mechanical outline drawing of the platform's midplane board.

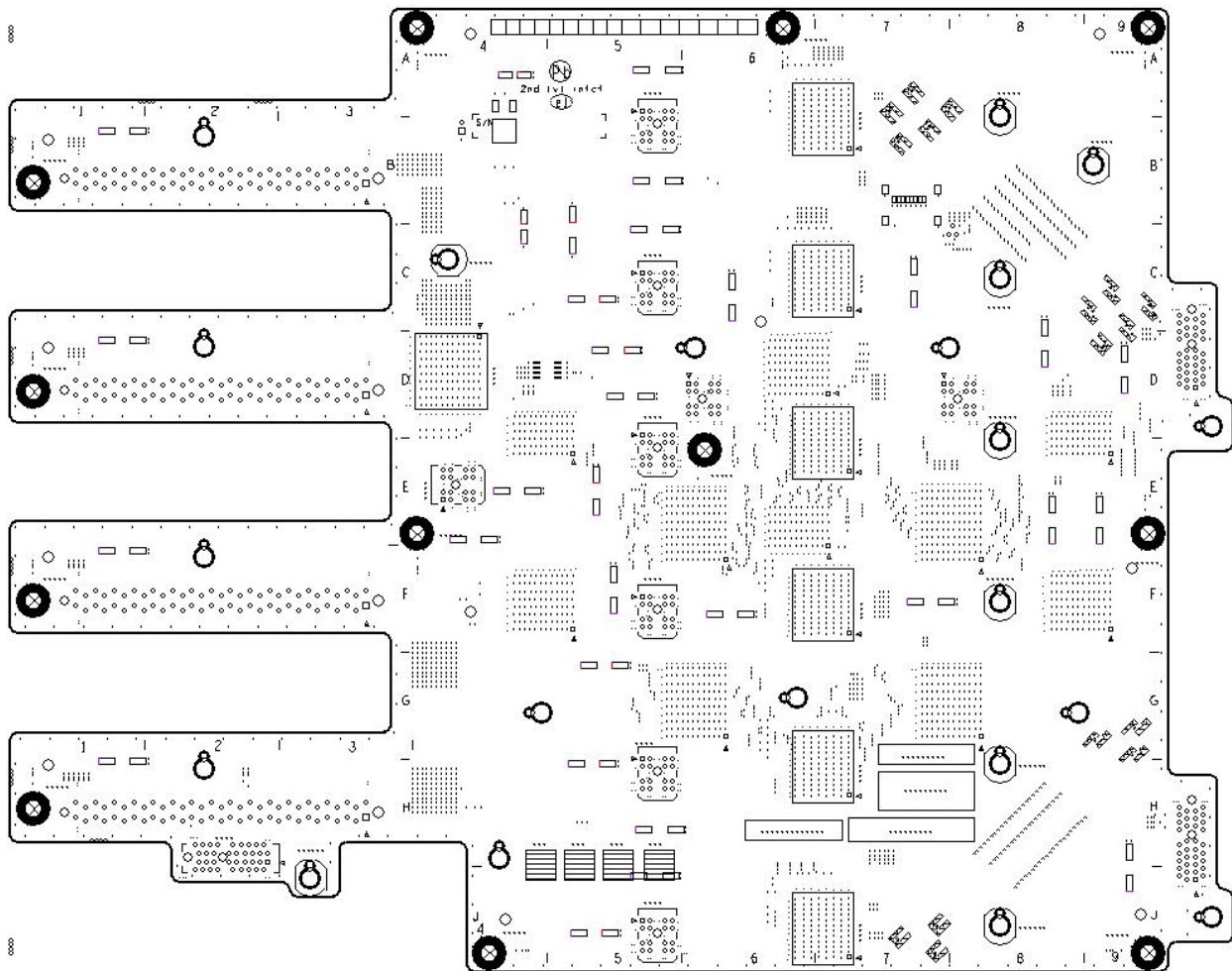

Figure 12. Midplane Board Mechanical Outline (Front View)

3.3.2 3D Renderings

This section contains perspective views of the midplane board.

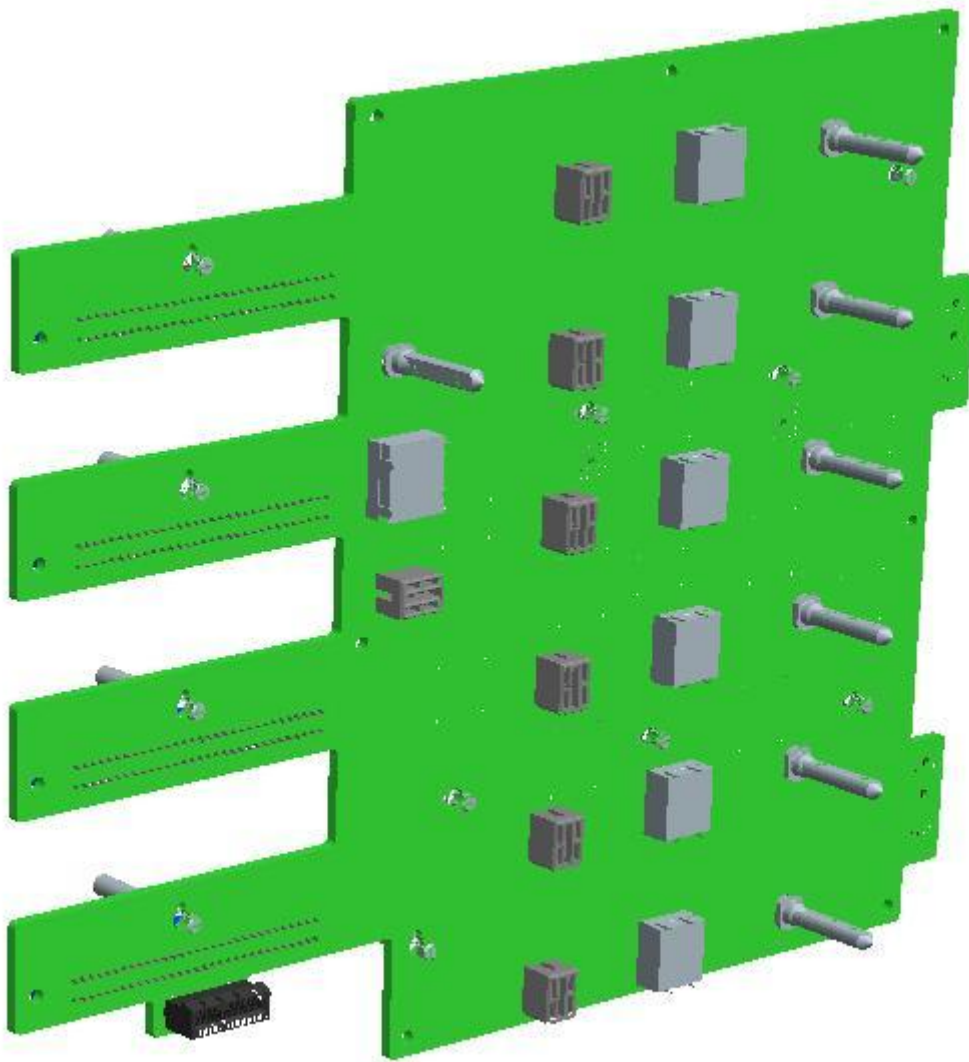

Figure 13. Front View of Midplane Board

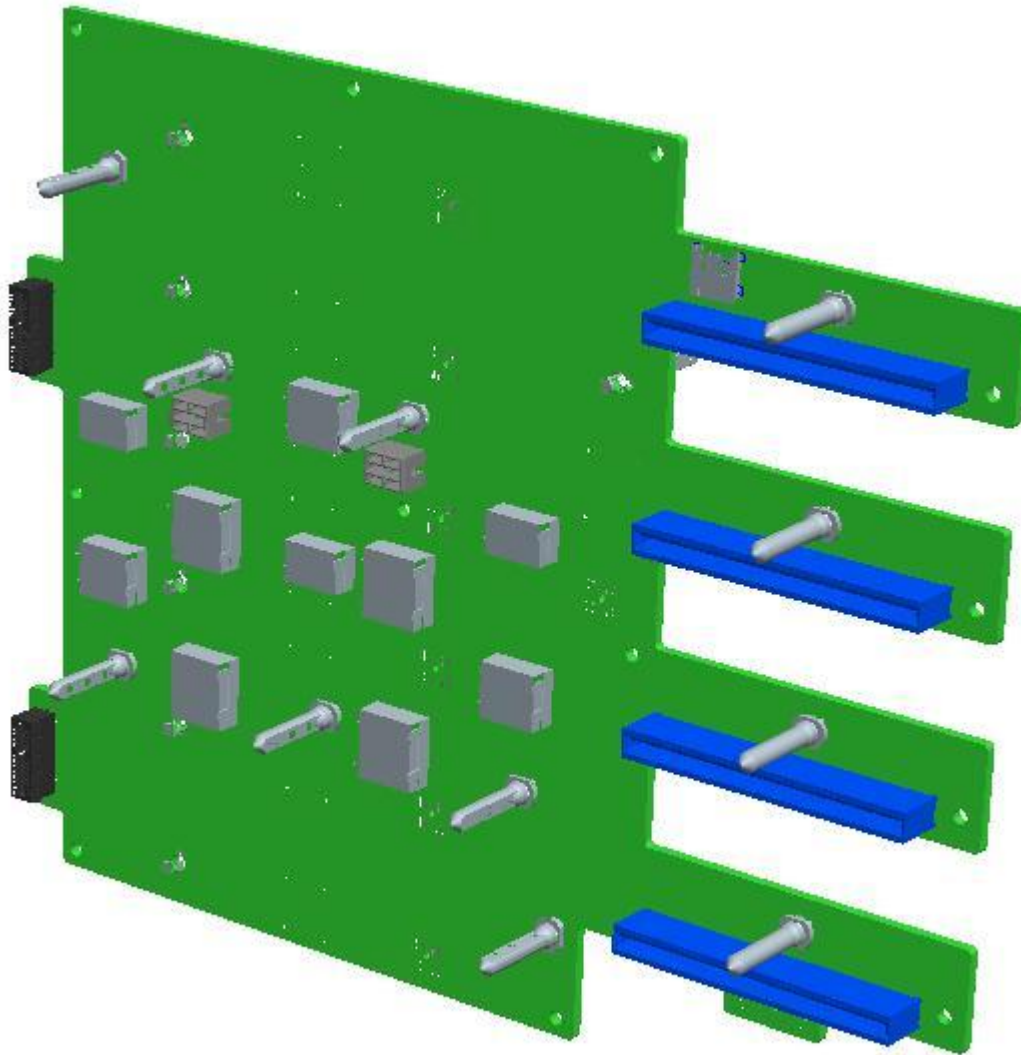

Figure 14. Rear View of Midplane Board

3.4 Compute Module

This section describes the platform's compute module at a high level. Refer to the *Intel® Compute Module MFS5000SI Technical Product Specification* for additional details.

3.4.1 Introduction

The Intel® Modular Server System MFSYS25/MFSYS35 architecture allows new compute modules to be developed around future processor/chipset combinations without any change to the rest of the system. Given that processor/chipset improvements have occurred more frequently than other technologies, such as I/O and storage, the compute module should be updated more often than other components in the system.

3.4.2 Drawings

This section contains perspective views of the compute module.

The following figure shows the front view of the module.



Figure 15. Front View of Compute Module

3.5 Chassis Management Module

This section describes the chassis management module (CMM) in the Intel® Modular Server System MFSYS25/MFSYS35.

3.5.1 Introduction

The server platform's chassis management module provides chassis-wide system management. It interfaces with all system components either via the I²C bus or via the Intel® Ethernet Switch Module. (The CMM connects via ethernet directly to the storage controller module(s) and the Intel® Ethernet Switch Module(s), and indirectly to the compute modules. There are no ethernet connections to the power supply modules, cooling modules, or LED boards.) The main components of the CMM are the IXP-425 microcontroller, which runs the Linux OS in addition to the built-in server control GUI, and the FPGA, which provides I²C bus expansion among other functionality.

3.5.2 Mechanical Outline

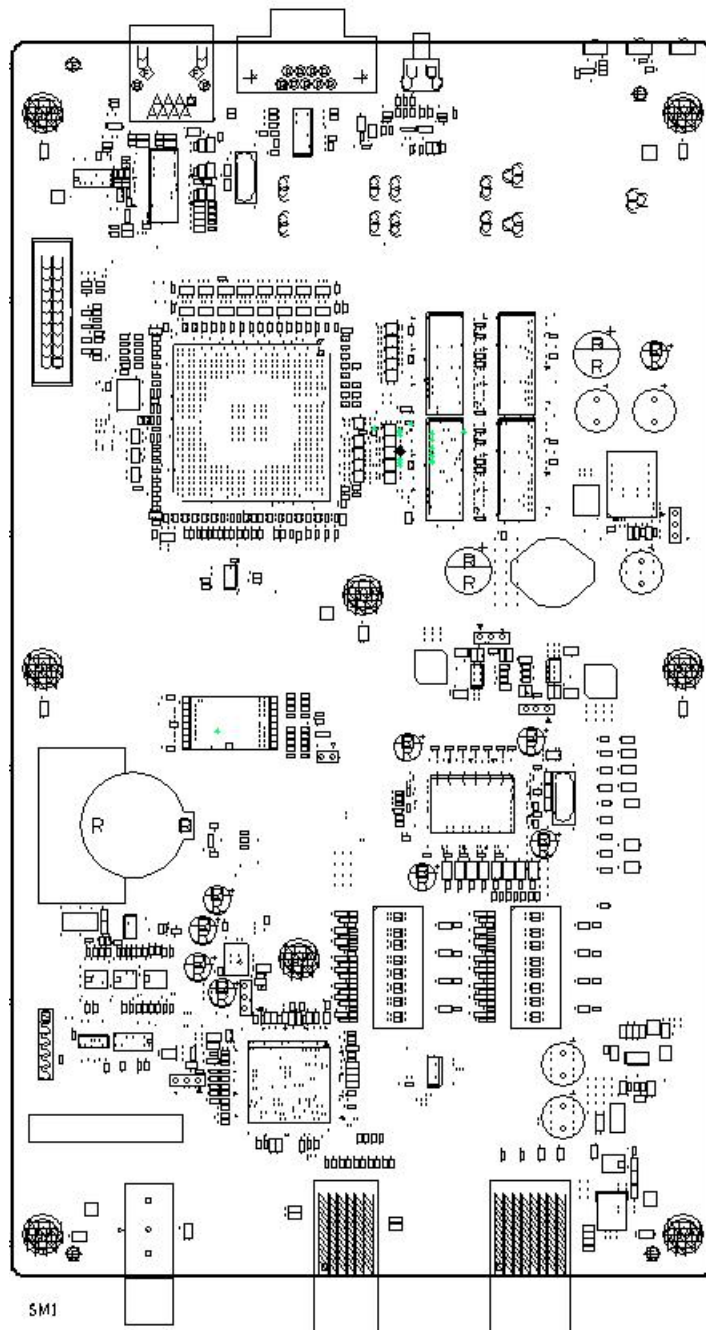

Figure 16. Chassis Management Module Board Outline (Top View)

3.5.3 Block Diagram

The following block diagram divides the chassis management module into physical and functional blocks. Arrows represent buses and signals. Blocks represent the physical and functional circuits. The following figure illustrates the general architecture of the chassis management module.

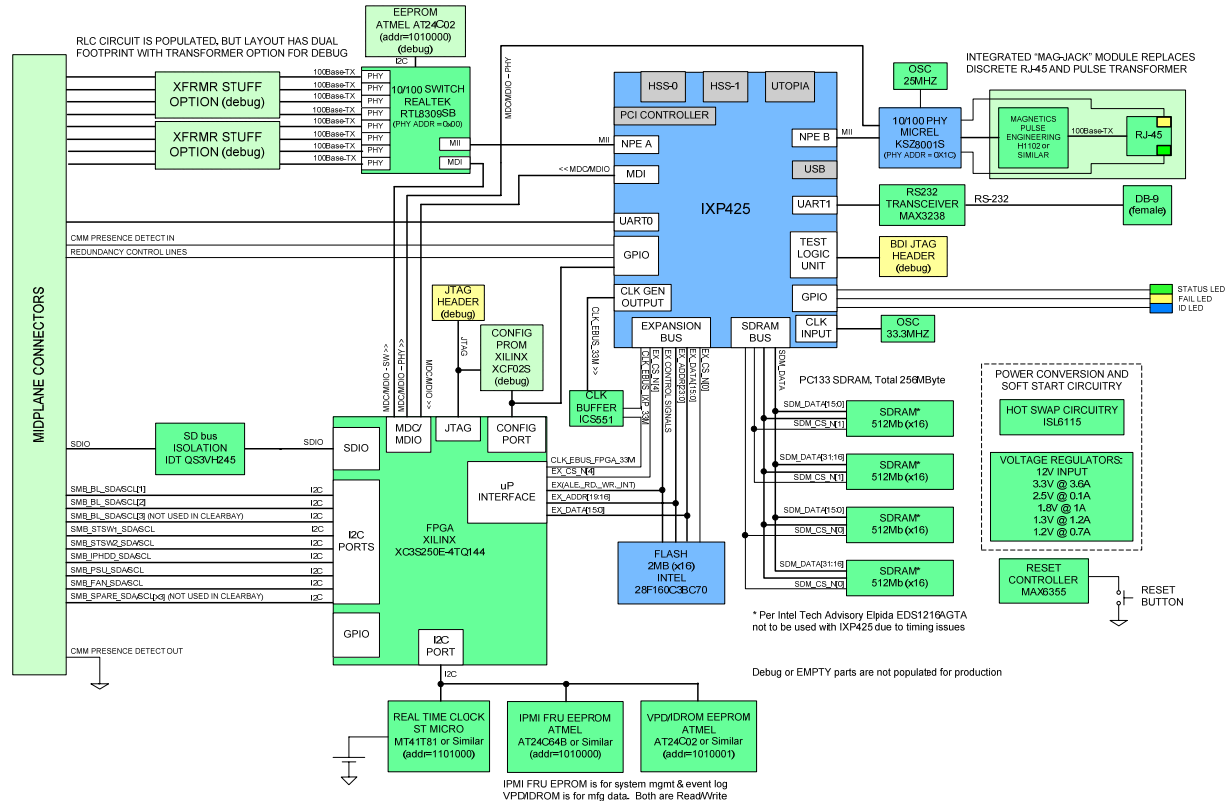

Figure 17. Chassis Management Module Block Diagram

3.5.4 Drawings

The following figure shows the front view of the CMM.



Figure 18. Front View of Chassis Management Module

3.5.5 Architectural Overview

The chassis management module provides configuration and management capabilities for the entire Intel® Modular Server System MFSYS25/MFSYS35. The CMM runs the Web browser-accessible Server Control. The 10/100 Ethernet port on the front panel of the CMM provides the main interface to the Intel® Modular Server System MFSYS25/MFSYS35.

The CMM runs the Linux operating system in addition to the built-in server control GUI application. Through the GUI, the customer can configure and manage any system component. Refer to the *Intel® Modular Server System MFSYS25/MFSYS35 User Guide* for more details on how to manage the system.

The CMM monitors platform management events and logs their occurrence. This includes events such as over-temperature and over-voltage conditions, fan failures, etc. The CMM also provides the interface to this monitored information so that system management software can poll and retrieve the present status of the platform.

The following is a list of the major functions of the CMM:

- System power control
 - Storage controllers
 - Ethernet switch modules
 - Compute modules
- System initialization
- System fan management
- System Event Log (SEL) interface
- FRU inventory
- Event message generation and reception
- Serial over LAN (SOL)
- Sensor monitoring

- Temperature
- Voltage
- Fan speed
- Processor status
- Power supplies
- IPMB communication interface
- Checks and forces automatic update of firmware of newly installed system boards to versions stored in the SD (secure digital) card on the midplane.
- CMM GUI provides remote KVM to the compute modules
- External serial port connector for local/remote management access
- External Ethernet connector for local/remote management

3.6 Ethernet Switch Module

3.6.1 Introduction

The Intel® Ethernet Switch Module (ESM) provides ethernet connectivity for the CMM to the compute modules and for the compute modules to an external network.

3.6.2 Mechanical Outline

The following figure shows the mechanical outline of the ESM.

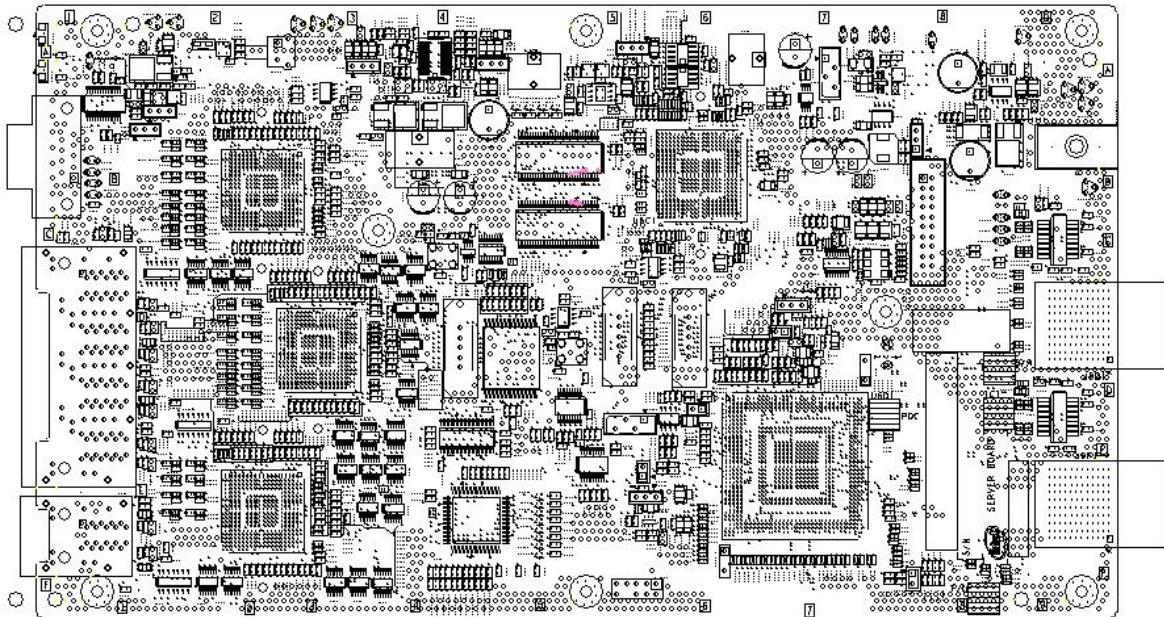

Figure 19. Ethernet Switch Module Mechanical Outline (Top View)

3.6.3 Block Diagram

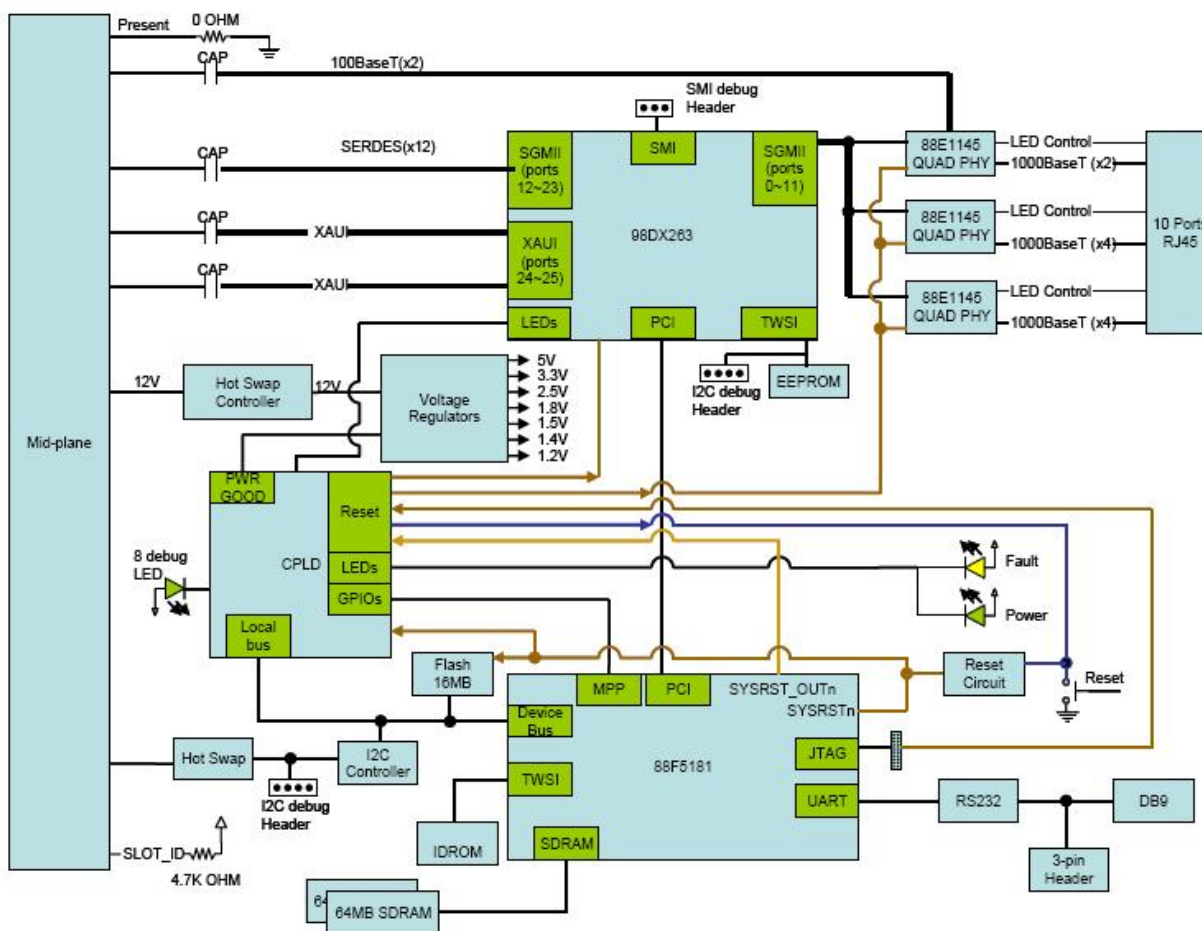

Figure 20. Ethernet Switch Module Block Diagram

3.6.4 Architectural Overview

The ESM provides networking and switch functions to the compute modules. Each compute module is capable of accessing up to two ESMs via point-to-point links across the midplane.

The ESM has ten (10) 1000BaseT external links to the outside, two (2) internal 10 Gbps XAU1 links (one to the other ESM and one to the storage controller), twelve (12) internal point-to-point 1Gbps serializer/deserializer (SerDes) links (two to each compute module), one point-to-point internal 10/100 Mbps link to the CMM, and one I²C interface to the CMM (for the CMM to configure and control the ESM).

3.7 Storage Controller Module

3.7.1 Storage Subsystem Introduction

The Intel® Modular Server System MFSYS25/MFSYS35 enables up to six diskless compute modules to interface via SAS connections to one or two (for redundancy) internal storage controller modules. The storage controller modules include RAID and storage virtualization functionality with connections to back-end shared internal SAS disk drives. Connectivity between the storage controller modules and the disk drive backplane is achieved via an interposer card to a 14-drive backplane in the Intel® Modular Server System MFSYS25 and a 6-drive backplane in the Intel® Server System MFSYS35. In combination, these components allow up to 14 2.5-inch SAS drives in the Intel® Modular Server System MFSYS25 and up to 6 3.5-inch SAS/SATA drives in the Intel® Modular Server System MFSYS35 to be shared between all compute modules. The CMM is used to configure drive arrays and to match LUNs to specific compute modules.

3.7.2 Mechanical Outline

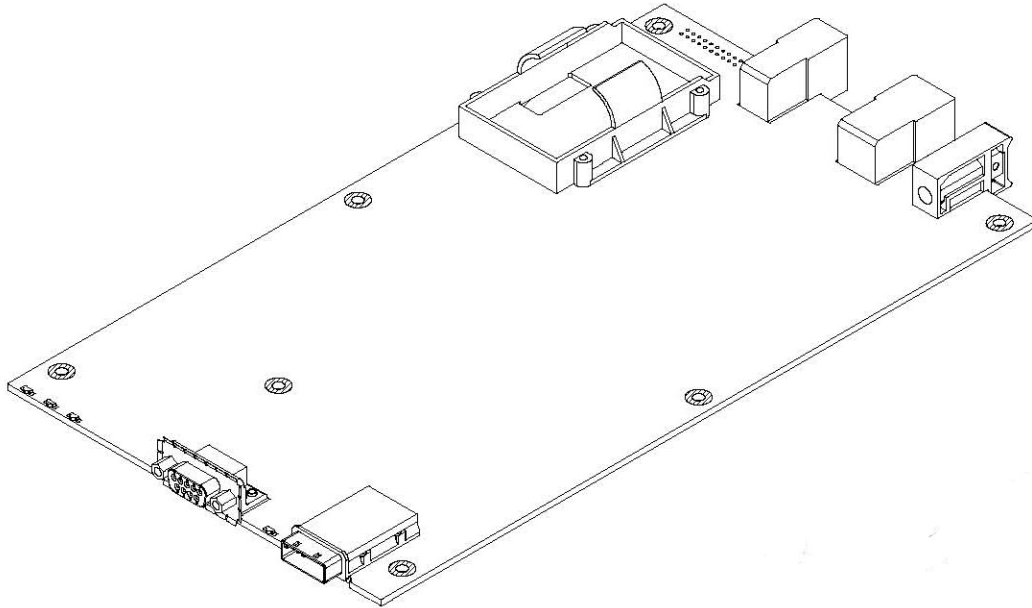

Figure 21. Mechanical Outline of Storage Controller Module Board

3.7.3 Storage Controller Module View



Figure 22. Front View of Storage Controller Module

3.7.4 Architectural Overview

3.7.4.1 Storage Controller Module Interface

The Interposer SAS signals from the storage controller module (SCM) originate from the LSI* 1068 and PM8399* devices.

A hardware reset line for each expander originates from each SCM. One SAS expander on the Interposer is managed by one SCM; the second expander is managed by the second SCM (if installed).

An I²C bus connects the SCM(s) to the Interposer VPD SEEPROM and each expander. The SCM(s) can retrieve hardware monitor and drive backplane IDROM information from the expanders, which are connected via I²C to these devices.

Disk drive status is communicated via SES pages to the expanders from the RAID stack in the SCM, and this status is exported to GPIO LED signals, one for each disk drive. One overall RAID status LED is also sent via SES and exported to a single LED.

Expander firmware can be downloaded from the SCM.

3.7.4.2 Interposer Card Functionality

SAS expander-1 provides connectivity to all disk drive “A” ports; SAS expander-2 provides connectivity to all disk drive “B” ports. “A” port SAS traffic originates only from SCM-1, and “B” port SAS traffic originates only from SCM-2. The SAS connection from SCM-1 to expander-2 (and SCM-2 to expander-1) is intended for high-speed controller to controller traffic only (write cache mirroring).

12 V bulk power is provided by the midplane. The Interposer has a power converter function for internal needs, and also supplies the disk drive power (12 V boost may be required).

The VPD SEEPROM contains a WW (World Wide) unique address which the SCM uses to derive a SAS WWN (World Wide Name). It also contains manufacturing data, such as serial and version numbers for the Interposer.

Hardware monitoring on the Interposer includes a temperature sensor. The data is passed back to the SCM via expander SES pages.

Disk drive status LEDs are driven by expander GPIO signals, and collaboration logic must be present on the Interposer since either SCM (and either expander) can drive the status LEDs.

3.7.4.3 Drive Backplane Interface

The Interposer converts bulk 12 V from the midplane to provide +5 V and +12 V for disk drive power. Sufficient current is supplied for sequenced spin-up of drives in groups of 4-4-2-2-2 (for 2.5-inch configurations). Supported drive types include 15K RPM SAS drives.

Signals are provided for single-color status LEDs for each disk drive.

An expander sourced I²C bus is connected to the drive backplane IDROM.

Expanders send appropriate command/signal to an optional SATA active/active MUX dongle card on disk drive carriers to control 5 V and 12 V power.

3.8 Power Supply Module

The power supply module in Intel® Modular Server System MFSYS25/MFSYS35 is a 1000-W DC output supply with 110-240V AC input. Each power supply includes two fans that provide cooling for optional hot-swap disk drives.

The power subsystem is configured as follows:

- With four power supply modules installed, a fully configured system has (3+1) power redundancy.
- With three power supply modules installed, a fully configured system would not have redundant power.

Three power supply modules are capable of handling the maximum power requirements for fully configured platforms, which includes six compute modules, 192 GB of memory, two storage controllers, two Ethernet switch modules, one chassis management module, and fourteen hot-swap 2.5-inch hard disk drives or six hot-swap 3.5-inch hard disk drives.

When four power supply modules are installed, the user can replace a failed power supply module without affecting system functionality. Power supplies have two LEDs to identify failure, power good and AC OK.

The power subsystem receives AC power through four power cords.

Note: The total power requirement for the platforms exceeds the 240 VA energy hazard limits that define an operator accessible area. As a result, only qualified technical individuals should access the processor and non-hot-plug I/O areas while the system is energized. Power cords should be removed from the system before accessing non-hot-plug areas.

3.9 Jumpers and LEDs

The compute module is the only module with jumper headers. Refer to the *Intel® Compute Module MFS5000SI Technical Product Specification* for details on the function and location of the server jumpers.

4. Product Regulatory Requirements

4.1 Product Regulatory Compliance

The Server Chassis product, when correctly integrated per this document, complies with the following safety, electromagnetic compatibility (EMC, and Product Ecology regulations and requirements.

Intended Application - This product was evaluated as Information Technology Equipment (ITE), which may be installed in offices, schools, computer rooms, and similar commercial type locations. The suitability of this product for other product categories and environments (such as: medical, industrial, telecommunications, NEBS, residential, alarm systems, test equipment, etc.), other than an ITE application, may require further evaluation.

4.1.1 Product Safety Compliance

UL60950 - CSA 60950(USA / Canada)
EN60950 (Europe)
IEC60950 (International)
CB Certificate & Report, IEC60950 (report to include all country national deviations)
GS Certification (Germany)
GOST R 50377-92 - Certification (Russia)
Belarus Certification (Belarus)
Ukraine Certification (Ukraine)
CE - Low Voltage Directive 73/23/EEE (Europe)
IRAM Certification (Argentina)
GB4943- CNCA Certification (China)

4.1.2 Product EMC Compliance - Class A Compliance

FCC /ICES-003 - Emissions (USA/Canada) Verification
CISPR 22 - Emissions (International)
EN55022 - Emissions (Europe)
EN55024 - Immunity (Europe)
EN61000-3-2 - Harmonics (Europe)
EN61000-3-3 - Voltage Flicker (Europe)
CE - EMC Directive 89/336/EEC (Europe)
VCCI Emissions (Japan)
AS/NZS 3548 Emissions (Australia / New Zealand)
BSMI CNS13438 Emissions (Taiwan)
GOST R 29216-91 Emissions (Russia)
GOST R 50628-95 Immunity (Russia)
Belarus Certification (Belarus)
Ukraine Certification (Ukraine)
KCC Notice No. 1997-41 (EMC) & 1997-42 (EMI) (Korea)
GB 9254 - CNCA Certification (China)
GB 17625 - (Harmonics) CNCA Certification (China)

4.1.3 Product Ecology Compliance

Intel has a system in place to restrict the use of banned substances in accordance with world wide regulatory requirements. A Material Declaration Data Sheet is available for Intel products. For more reference on material restrictions and compliance you can view Intel's Environmental Product Content Specification at <http://supplier.intel.com/ehs/environmental.htm>.

Europe - European Directive 2002/95/EC

Restriction of Hazardous Substances (RoHS)

Threshold limits and banned substances are noted below.

Quantity limit of 0.1% by mass (1000 PPM) for:

Lead, Mercury, Hexavalent Chromium, Polybrominated Biphenyls Diphenyl Ethers (PBB/PBDE)

Quantity limit of 0.01% by mass (100 PPM) for:

Cadmium

California Code of Regulations, Title 22, Division 4.5, Chapter 33:

Best Management Practices for Perchlorate Materials

China - Restriction of Hazardous Substances (China RoHS)

WEEE Directive (Europe)

Packaging Directive (Europe)

4.1.4 Certifications / Registrations / Declarations

UL Certification (US/Canada)

CE Declaration of Conformity (CENELEC Europe)

FCC/ICES-003 Class A Attestation (USA/Canada)

VCCI Certification (Japan)

C-Tick Declaration of Conformity (Australia)

MED Declaration of Conformity (New Zealand)

BSMI Certification (Taiwan)

GOST R Certification / License (Russia)

Belarus Certification / License (Belarus)

KCC Certification (Korea)

IRAM Certification (Argentina)

CNCA Certification (China)



Ecology Declaration (International)





China RoHS Environmental Friendly Use Period

Packaging & Product Recycling Marks

4.2 Product Regulatory Compliance Markings

This Intel Server Chassis product is provided with the following regulatory and safety markings. In the event there is no room for a marking(s) on the chassis, the information is provided here in this document.

Requirement	Country	Marking
cULus Listing Marks	USA/Canada	
GS Mark	Germany	
CE Mark	Europe	
FCC Marking (Class A)	USA	<p>This device complies with Part 15 of the FCC Rules. Operation of this device is subject to the following two conditions: (1) This device may not cause harmful interference, and (2) This device must accept any interference received, including interference that may cause undesired operation. Manufactured by Intel Corporation</p>
EMC Marking (Class A)	Canada	<p>CANADA ICES-003 CLASS A CANADA NMB-003 CLASSE A</p>
VCCI Marking (Class A)	Japan	<p>この装置は、クラス A 情報技術装置です。この装置を家庭環境で使用すると電波妨害を引き起こすことがあります。この場合には使用者が適切な対策を講ずるよう要求されることがあります。VCCI-A</p>

Requirement	Country	Marking
BSMI Certification & Class A Warning	Taiwan	 <div style="border: 1px solid black; padding: 5px; margin-top: 10px;"> <p>警告使用者： 這是甲類的資訊產品，在居住的環境中使用時，可能會造成射頻干擾，在這種情況下，使用者會被要求採取某些適當的對策</p> </div>
GOST R Marking	Russia	
KCC Mark	Korea	<p>Note: The following is the former Korean EMC mark and is seen on older Intel products.</p> 
KCC Mark	Korea	<p>Note: The following symbol is the new Korean EMC mark and is seen on newer Intel products.</p> 
China Compulsory Certification Mark	China	
<p>于符合中国《电子信息产品污染控制管理法》的声明 Management Methods on Control of Pollution from Electronic Information Products (China RoHS declaration) 品中有毒有害物. 的名称及含量</p>		
部件名称 (Parts)		
	有毒有害物. 或元素	

Requirement	Country	Marking					
		铅 (Pb)	汞 (Hg)	镉 (Cd)	六价铬 (Cr6+)	多溴联苯 (PBB)	多溴二苯醚 (PBDE)
金属部件 (Metal Parts)		○	○	○	x	○	○
印刷板. 件 (Printed Board Assemblies (PBA))		x	○	○	○	○	○

○：表'有毒有害物. 在. 部件所有均. 材料中的含量均在SJ/T 11363-2006 . 准. 定的限量要求以下。





○：
Indicates that this hazardous substance contained in all homogeneous materials of this part is below the limit requirement in SJ/T 11363-2006.



x：表'有毒有害物. 至少在. 部件的某一均. 材料中的含量超出SJ/T 11363-2006 . 准. 定的限量要求。

x：
Indicates that this hazardous substance contained in at least one of the homogeneous materials of this part is above the limit requirement in SJ/T 11363-2006.

售之日的所售. 品, 本表'示我公司供. . 的. 子信息. 品可能'含. 些物. 。注意：在
所售. 品中可能'也可能'会含有所有所列的部件

This table shows where these substances may be found in the supply chain of our electronic information products, as of the date of sale of the enclosed product. Note that some of the component types listed above may or may not be a part of the enclosed product.

Requirement	Country	Marking
Belarus Safety Compliance Mark	Belarus	
Waste of Electronic and Electrical Equipment Recycling Mark	Europe	
China Restriction of Hazardous Substance Environmental Friendly Use Period Mark	China	
China Recycling Mark	China	
Recycling Marks	International	
Battery Perchlorate Warning Information	California	<p>Perchlorate Material - Special handling may apply. See www.dtsc.ca.gov/hazardouswaste/perchlorate</p> <p>This notice is required by California Code of Regulations, Title 22, Division 4.5, and Chapter 33: Best Management Practices for Perchlorate Materials. This product may include a battery which contains Perchlorate material.</p>

Requirement	Country	Marking
Safety	Multiple Power Cord Marking	 <p>This unit has more than one power supply cord. To reduce the risk of electrical shock, disconnect (2) two power supply cords before servicing.</p> <p>Simplified Chinese:</p> <p>注意： 本设备包括多条电源系统电缆。为避免遭受电击，在进行维修之前应断开两（2）条电源系统电缆。</p> <p>Traditional Chinese:</p> <p>注意： 本設備包括多條電源系統電纜。為避免遭受電擊，在進行維修之前應斷開兩（2）條電源系統電纜。</p> <p>German:</p> <p>Dieses GerŠte hat mehr als ein Stromkabel. Um eine Gefahr des elektrischen Schlages zu verringern trennen sie beide (2) Stromkabeln bevor Instandhaltung.</p>
Nordic Countries	Connection to Proper Ground Outlet	<p>"WARNING:"</p> <p>"Apparaten skall anslutas till jordat uttag, nŠr den ansluts till ett nŠtverk."</p> <p>"Laite on liitettŠvŠ suojamaadoituskoskettimilla varustettuun pistorasiaan."</p> <p>"Connect only to a properly earth grounded outlet."</p>
Safety	Standby power	

4.3 Regulated Specified Components

To maintain the UL listing and compliance to other regulatory certifications and/or declarations, the following regulated components must be used and conditions adhered to. Interchanging or use of other component will void the UL listing and other product certifications and approvals.

You can find updated product information for configurations on the Intel Server Builder Web site at the following URL: <http://channel.intel.com/go/serverbuilder>

If you do not have access to Intel's Web address, contact your local Intel representative.

1. **Server Chassis:** Base chassis is provided with power supply and fans—UL listed.
2. **Server board:** You must use an Intel server board—UL recognized.

3. **Add-in Boards:** Must have a printed wiring board flammability rating of minimum UL94V-1. Add-in boards containing external power connectors and/or lithium batteries must be UL recognized or UL listed. Any add-in board containing modem telecommunication circuitry must be UL listed. In addition, the modem must have the appropriate telecommunications, safety, and EMC approvals for the region in which it is sold.
4. **Peripheral Storage Devices:** Must be UL recognized or UL listed accessory and TUV or VDE licensed. Maximum power rating of any one device is 19 watts. Total server configuration is not to exceed the maximum loading conditions of the power supply.

4.4 Electromagnetic Compatibility Notices

4.4.1 FCC Verification Statement (USA)

This device complies with Part 15 of the FCC Rules. Operation is subject to the following two conditions: (1) This device may not cause harmful interference, and (2) this device must accept any interference received, including interference that may cause undesired operation.

Intel Corporation
5200 N.E. Elam Young Parkway
Hillsboro, OR 97124-6497
Phone: 1-800-628-8686

This equipment has been tested and found to comply with the limits for a Class A digital device, pursuant to Part 15 of the FCC Rules. These limits are designed to provide reasonable protection against harmful interference in a residential installation. This equipment generates, uses, and can radiate radio frequency energy and, if not installed and used in accordance with the instructions, may cause harmful interference to radio communications. However, there is no guarantee that interference will not occur in a particular installation. If this equipment does cause harmful interference to radio or television reception, which can be determined by turning the equipment off and on, the user is encouraged to try to correct the interference by one or more of the following measures:

- Reorient or relocate the receiving antenna.
- Increase the separation between the equipment and the receiver.
- Connect the equipment into an outlet on a circuit different from that to which the receiver is connected.
- Consult the dealer or an experienced radio/TV technician for help.

Any changes or modifications not expressly approved by the grantee of this device could void the user's authority to operate the equipment. The customer is responsible for ensuring compliance of the modified product.

Only peripherals (computer input/output devices, terminals, printers, etc.) that comply with FCC Class A or B limits may be attached to this computer product. Operation with noncompliant peripherals is likely to result in interference to radio and TV reception.

All cables used to connect to peripherals must be shielded and grounded. Operation with cables, connected to peripherals that are not shielded and grounded may result in interference to radio and TV reception.

4.4.2 ICES-003 (Canada)

Cet appareil numérique respecte les limites bruits radioélectriques applicables aux appareils numériques de Classe A prescrites dans la norme sur le matériel brouilleur: "Appareils Numériques", NMB-003 dictée par le Ministre Canadien des Communications.

English translation of the notice above:

This digital apparatus does not exceed the Class A limits for radio noise emissions from digital apparatus set out in the interference-causing equipment standard entitled "Digital Apparatus," ICES-003 of the Canadian Department of Communications.

Recycle battery in accordance with applicable WEEE and Battery laws.



Perchlorate Material - special handling may apply. See:

<http://www.dtsc.ca.gov/hazardouswaste/perchlorate>

This notice is required by California Code of Regulations, Title 22, Division 4.5, Chapter 33: Best Management Practices for Perchlorate Materials. This product/part includes a battery which contains perchlorate material.

4.4.3 Europe (CE Declaration of Conformity)

This product has been tested in accordance too, and complies with the Low Voltage Directive (73/23/EEC) and EMC Directive (89/336/EEC). The product has been marked with the CE Mark to illustrate its compliance.

Recycle battery in accordance with applicable WEEE and Battery laws.



Perchlorate Material - special handling may apply. See:

<http://www.dtsc.ca.gov/hazardouswaste/perchlorate>

This notice is required by California Code of Regulations, Title 22, Division 4.5, Chapter 33: Best Management Practices for Perchlorate Materials. This product/part includes a battery which contains perchlorate material.

4.4.4 VCCI (Japan)

この装置は、情報処理装置等電波障害自主規制協議会（VCCI）の基準に基づくクラスA情報技術装置です。この装置を家庭環境で使用すると電波妨害を引き起こすことがあります。この場合には使用者が適切な対策を講ずるよう要求されることがあります。

English translation of the notice above:

This is a Class A product based on the standard of the Voluntary Control Council for Interference (VCCI) from Information Technology Equipment. If this is used near a radio or television receiver in a domestic environment, it may cause radio interference. Install and use the equipment according to the instruction manual.

Recycle battery in accordance with applicable WEEE and Battery laws.



Perchlorate Material - special handling may apply. See:

<http://www.dtsc.ca.gov/hazardouswaste/perchlorate>

This notice is required by California Code of Regulations, Title 22, Division 4.5, Chapter 33: Best Management Practices for Perchlorate Materials. This product/part includes a battery which contains perchlorate material.

4.4.5 BSMI (Taiwan)

The BSMI Certification Marking and EMC warning is located on the outside rear area of the product.

警告使用者：
這是甲類的資訊產品，在居住的環境中使用時，
可能會造成射頻干擾，在這種情況下，使用者會
被要求採取某些適當的對策

Recycle battery in accordance with applicable WEEE and Battery laws.



Perchlorate Material - special handling may apply. See:

<http://www.dtsc.ca.gov/hazardouswaste/perchlorate>

This notice is required by California Code of Regulations, Title 22, Division 4.5, Chapter 33: Best Management Practices for Perchlorate Materials. This product/part includes a battery which contains perchlorate material.

Glossary

This appendix contains important terms used in the preceding sections. Acronyms are followed by non-acronyms.

Word / Acronym	Definition
ACPI	Advanced Configuration and Power Interface
BIOS	Basic Input / Output System
BMC	Baseboard Management Controller
CE	European Conformity (Conformité Européenne)
CISPR	Special International Committee on Radio Interference (Comité International Spécial des Perturbations Radioélectriques)
CMM	Chassis Management Module
CMOS	Complementary Metal-Oxide Semiconductor
CSA	Canadian Standards Organization
DB	Data Bus
dBa	Decibel Acoustic
DDR2	Double Data Rate
DIMM	Dual In-line Memory Module
DMA	Direct Memory Access
ECC	Error Checking Code
EEPROM	Electrically Erasable Programmable Read-Only Memory
EMC	Electromagnetic Compatibility
EMI	Electromagnetic Interference
EMP	Emergency Management Port
EPS	External Product Specification
ESD	Electrostatic Discharge
ESM	Ethernet Switch Module
FCC	Federal Communications Commission
FPGA	Field-Programmable Gate Array
FRB	Fault Resilient Booting
FRU	Field Replaceable Unit
FSB	Front Side Bus
FWH	Firmware Hub
GbE	Gigabit Ethernet
GND	Ground
GUI	Graphical User Interface
HDD	Hard Disk Drive
HL	Hub-Link
HSC	Hot-Swap Controller
I/O	Input / Output
I ² C	Inter-Integrated Circuit
ICMB	Intelligent Chassis Management Bus
IDE	Integrated Device Electronics
IEC	International Electrotechnical Commission

Word / Acronym	Definition
IMB	Intelligent Management Bus
IPMB	Intelligent Platform Management Bus
IPMI	Intelligent Platform Management Interface
ISP	In-System Programmable
ITE	Information Technology Equipment
ITP	In-Target Probe
JTAG	Joint Test Action Group
KVM	Keyboard, VDU, and Mouse
LAN	Local Area Network
LED	Light Emitting Diode
LPC	Low-Pin Count
LVDS	Low Voltage Differential SCSI
NIC	Network Interface Card
OEM	Original Equipment Manufacturer
OS	Operating System
OTP	Over-Temperature Protection
PCI	Peripheral Component Interconnect
PDB	Power Distribution Board
PEF	Platform Event Filtering
PEP	Platform Event Paging
PFC	Power Factor Correction
PIROM	Processor Information Read-Only Memory
PLD	Programmable Logic Device
PSM	Power Supply Module
PSU	Power Supply Unit
PWM	Pulse Width Modulator
RAID	Redundant Array of Independent Disks
RAS	Reliability, Availability, and Serviceability
RASUM	Reliability, Availability, Serviceability, Usability, and Manageability
ROMB	RAID On Motherboard
RPM	Revolutions Per Minute
RoHS	Restriction of Hazardous Substances
SAF-TE	SCSI Accessed Fault-Tolerant Enclosure
SAS	Serial Attached SCSI
SATA	Serial Advanced Technology Attachment
SCA	Single Connector Attachment
SCL	Serial Clock
SCM	Switch Controller Module
SCSI	Small Computer Systems Interface
SDA	Serial Data
SDINT	System Diagnostic Interrupt
SDR	Sensor Data Record
SDRAM	Synchronous Dynamic Random Access Memory
SE	Single-Ended

Word / Acronym	Definition
SEEPROM	Serial Electrically Erasable Programmable Read-Only Memory
SEL	System Event Log
SerDes	Serializer/Deserializer
SMASH CLP	Systems Management Architecture for Server Hardware/Command Line Protocol
SMP	Symmetric Multiprocessing
SNMP	Simple Network Management Protocol
SOL	Serial Over LAN
TTL	Transistor-Transistor Logic
TUV	Technical Monitoring Association (Technischer Überwachungsverein)
USB	Universal Serial Bus
UL	Underwriters Laboratories, Inc.
UV	Under-Voltage
VAC	Alternating Current (AC) voltage
VCC	Voltage Controlled Current
VCCI	Voluntary Control Council for Interference by Information Technology Equipment
VDE	Association for Electrical, Electronic and Information Technologies (Verband der Elektrotechnik, Elektronik und Informationstechnik)
VDU	Video Display Unit
VGA	Video Graphics Array
VID	Voltage Identifier
VRM	Voltage Regulator Module
VSB	Voltage Standby
WfM	Wired for Management
WS	Web Services
WS-MAN	WS-Management
XAUI	10-Gigabit Attachment Unit Interface

Reference Documents

See the following documents for additional information:

- *SCSI Accessed Fault-Tolerant Enclosures Interface Specification (SAF-TE)*
- *Intel® Compute Module MFS5000SI Technical Product Specification (TPS)*
- *Intel® Modular Server System MFSYS25/MFSYS35 Tested Hardware and Operating Systems List (THOL)*
- *IPMI Specification, Version 2.0*