

PLEASE CHECK WWW.MOLEX.COM FOR LATEST PART INFORMATION

Part Number: [0353120360](#)
Status: **Active**
Description: 2.50mm (.098") Pitch Header, Vertical, Shrouded, with Positive Lock, 3 Circuits, PA Polyamide (Nylon) 6/6, Glass-filled, Natural

Documents:

3D Model	Product Specification PS-35155-002 (PDF)
Packaging Specification (PDF)	RoHS Certificate of Compliance (PDF)
Drawing (PDF)	

Agency Certification

CSA	LR19980
TUV	E9450420E01
UL	E29179

General

Product Family	PCB Headers
Series	35312
Application	Wire-to-Board
Product Name	N/A

Physical

Breakaway	No
Circuits (Loaded)	3
Circuits (maximum)	3
Color - Resin	Natural
Durability (mating cycles max)	30
First Mate / Last Break	No
Flammability	94V-0
Glow-Wire Compliant	No
Guide to Mating Part	No
Keying to Mating Part	None
Lock to Mating Part	Yes
Material - Plating Mating	Tin
Material - Plating Termination	Tin
Material - Resin	Nylon
Number of Rows	1
Orientation	Vertical
PC Tail Length (in)	0.134 In
PC Tail Length (mm)	3.40 mm
PCB Locator	No
PCB Retention	None
PCB Thickness Recommended (in)	0.062 In
PCB Thickness Recommended (mm)	1.60 mm
Packaging Type	Bag
Pitch - Mating Interface (in)	0.098 In
Pitch - Mating Interface (mm)	2.50 mm
Plating min: Mating (µin)	200
Plating min: Mating (µm)	5
Plating min: Termination (µin)	200
Plating min: Termination (µm)	5
Polarized to PCB	No
Shrouded	Partial
Stackable	No
Surface Mount Compatible (SMC)	No
Temperature Range - Operating	-40°C to +105°C

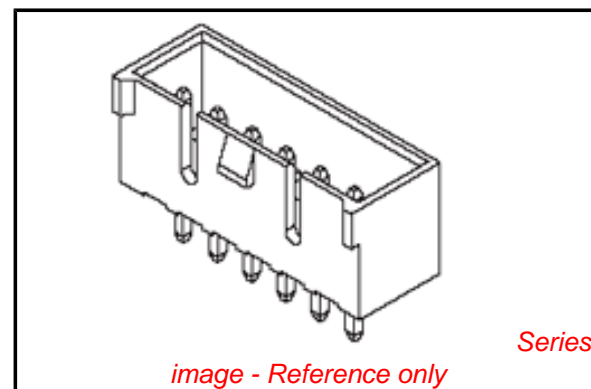

image - Reference only

EU RoHS

ELV and RoHS Compliant
REACH SVHC
 Not Reviewed
Halogen-Free Status

China RoHS



Need more information on product environmental compliance?

Email productcompliance@molex.com
 For a multiple part number RoHS Certificate of Compliance, [click here](#)

Please visit the [Contact Us](#) section for any non-product compliance questions.

Search Parts in this Series

[35312Series](#)

Mates With

Wire-to-Wire and Wire-to-Board Housing
[35572 Crimp Housing](#), [35155](#)

Termination Interface: Style

Through Hole

Electrical

Current - Maximum per Contact

3A

Voltage - Maximum

250V

Material Info

Reference - Drawing Numbers

Product Specification

PS-35155-002

Sales Drawing

SD-35312-001, SD-35312-004, SD-35312-005

This document was generated on 04/15/2010

PLEASE CHECK WWW.MOLEX.COM FOR LATEST PART INFORMATION

DWG. NO. SD-35312-001

SIMILAR ITEM 35312-***1*

PROJECT NO.

B

DO NOT SCALE DRAWING
DIMENSION IN METRIC

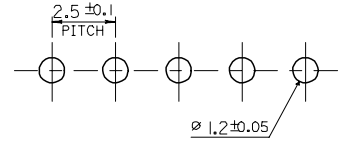
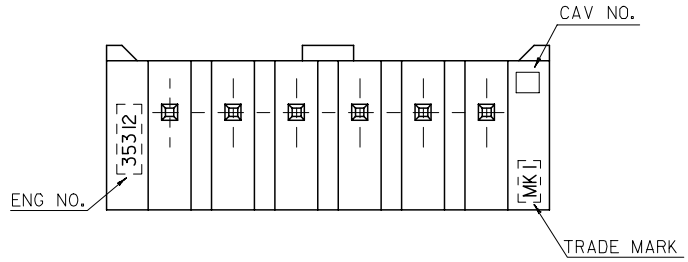
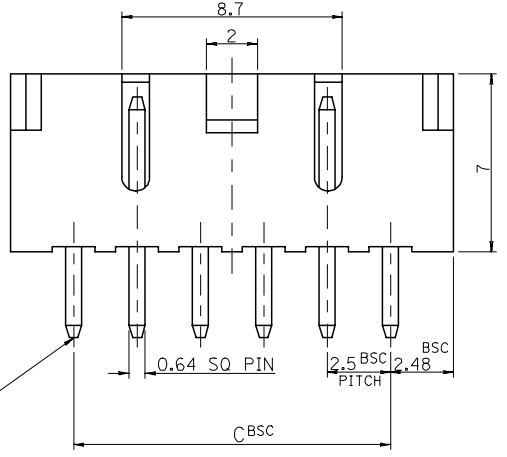
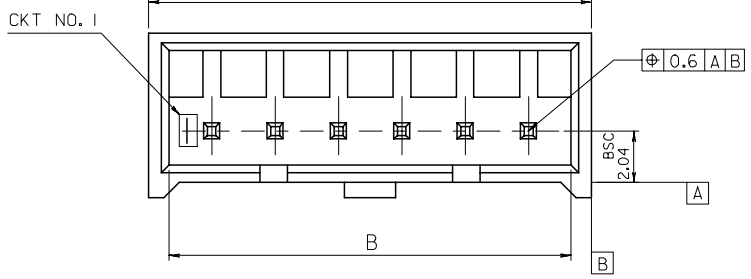
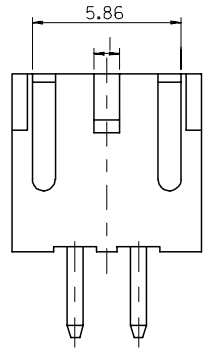
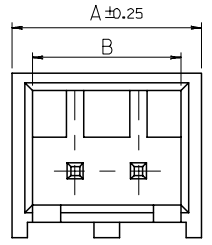

P.C. BOARD LAYOUT
THK.: 1.6±

NOTE

1. MATERIAL: WAFER : NYLON66, GLASS FILLED 20%
PIN : BRASS, TIN PLATED

② 2. LEGEND

35312 - ** 6 *

COLOR : 0 --- NATURAL
2 --- RED
3 --- YELLOW
4 --- BLUE

CKT(02,03,04....)

3. THIS PRODUCT SHALL BE COMPLIED WITH
ROHS COMPATIBLE(LEAD FREE SOLDERABILITY)

35	38.36	39.96	35312-156*	15
32.5	35.86	37.46	-146*	14
30	33.36	34.96	-136*	13
27.5	30.86	32.46	-126*	12
25	28.36	29.96	-116*	11
22.5	25.86	27.46	-106*	10
20	23.36	24.96	-096*	9
17.5	20.86	22.46	-086*	8
15	18.36	19.96	-076*	7
12.5	15.86	17.46	-066*	6
10	13.36	14.96	-056*	5
7.5	10.86	12.46	-046*	4
5	8.36	9.96	-036*	3
2.5	5.86	7.46	35312-026*	2
C	B	A	ENG NO.	CKT NO.

REVISED ECN NO. KOR2006-0105 DRWN: K.S.KIM 060323 CHK: K.S.KIM APPR: Y.SOO.KIM	DESCRIPTION MAJOR CRITICAL C	QUALITY SYMBOLS		GENERAL TOLERANCES: (UNLESS SPECIFIED)		SCALE 5-1	DESIGN UNITS <input checked="" type="checkbox"/> mm <input type="checkbox"/> INCH	THIRD ANGLE PROJECTION		DIMENSIONS: <input type="checkbox"/> mm <input type="checkbox"/> INCH <input checked="" type="checkbox"/> mm ONLY		SHT	REV
		4 PLACES	±0.	±.	4 PLACES	±0.	±.	DRAWN BY & DATE H.S.SHIN	TITLE: 2.5 PITCH W/B CONN. WAFER ASS'Y (WITH LOCK)				
B	REV	3 PLACES	±0.	±.	2 PLACES	±0.	±.	CHECKED BY & DATE Y.SOO.KIM	MOLEX INCORPORATED				
		2 PLACES	±0.	±.	1 PLACE	±0.2	±.	APPROVED BY & DATE S.H.CHOI					
DRAFT WHERE APPLICABLE MUST REMAIN WITHIN DIMENSIONS		ANGULAR: ± 2 °		CAD FILENAME		MATERIAL NO. 35312**6*	DRAWING NO. SD-35312-001	SHEET NO. 1 OF 1		KOREA		MX-A3	
THIS DRAWING CONTAINS INFORMATION THAT IS PROPRIETARY TO MOLEX INCORPORATED AND SHOULD NOT BE USED WITHOUT WRITTEN PERMISSION.										SIZE B			

PROJECT NO. SIMILAR ITEM DWG. NO. SD-35312-004

5 4 3 2 1

NOTE

1. TUBE THK.: 0.6±
2. LENGTH : 600mm
3. THIS PRODUCT SHALL BE COMPLIED WITH RoHS COMPATIBLE (LEAD FREE SOLDERABILITY)

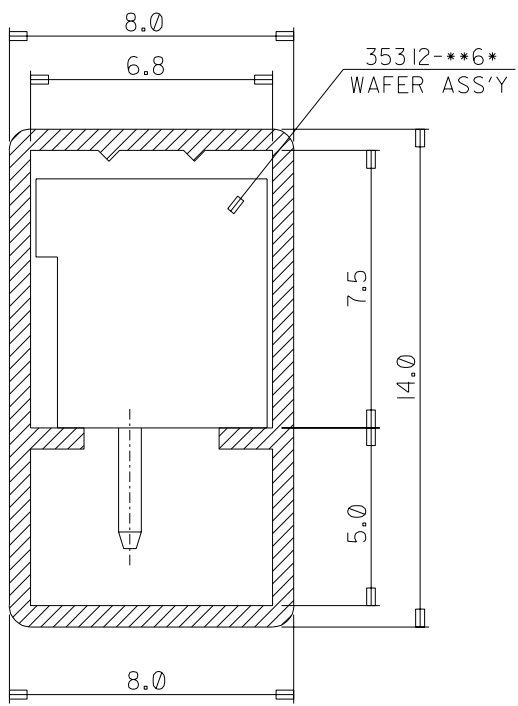

10	35312-1568	15P	35312 SERIES
15	-0468	14P	
15	-1468	13P	
15	-1268	12P	
15	-1168	11P	
20	-1068	10P	
20	-0968	9P	
25	-0868	8P	
25	-0768	7P	
30	-0668	6P	
35	-0568	5P	35312 SERIES
45	-0468	4P	
55	35312-0368	3P	
Q'TY	ENG NO.	CKT.	USED ON

NEW RELEASED EC NO. KOR2005-0066 DRWN: K.S.KIM 040722 CHK: Y.Soo.KIM APPR: C.W.LEE	DESCRIPTION MAJOR CRITICAL	QUALITY SYMBOLS		GENERAL TOLERANCES: (UNLESS SPECIFIED)		SCALE 5-1	DESIGN UNITS <input checked="" type="checkbox"/> mm <input type="checkbox"/> INCH	THIRD ANGLE PROJECTION	DIMENSIONS: <input type="checkbox"/> mm <input type="checkbox"/> INCH <input checked="" type="checkbox"/> mm ONLY		SHT	REV
		4 PLACES	±0.	±.	3 PLACES	±0.	±.	DRAWN BY & DATE K.S.KIM		TITLE: PACKING FOR 35312 (S/S C-TV)		
A	REV	2 PLACES	±0.	±.	1 PLACE	±0.3	±.	APPROVED BY & DATE C.W.LEE		MOLEX INCORPORATED		
		ANGULAR: ± 2 °		CAD FILENAME		MATERIAL NO. 35312-***68	DRAWING NO. SD-35312-004	SHEET NO. 1/1		THIS DRAWING CONTAINS INFORMATION THAT IS PROPRIETARY TO MOLEX INCORPORATED AND SHOULD NOT BE USED WITHOUT WRITTEN PERMISSION.		
DRAFT WHERE APPLICABLE MUST REMAIN WITHIN DIMENSIONS		SIZE A										

5 4 3 2 1 MX-A4

PROJECT NO. SIMILAR ITEM DWG. NO. SD-35312-005

35312-**-19

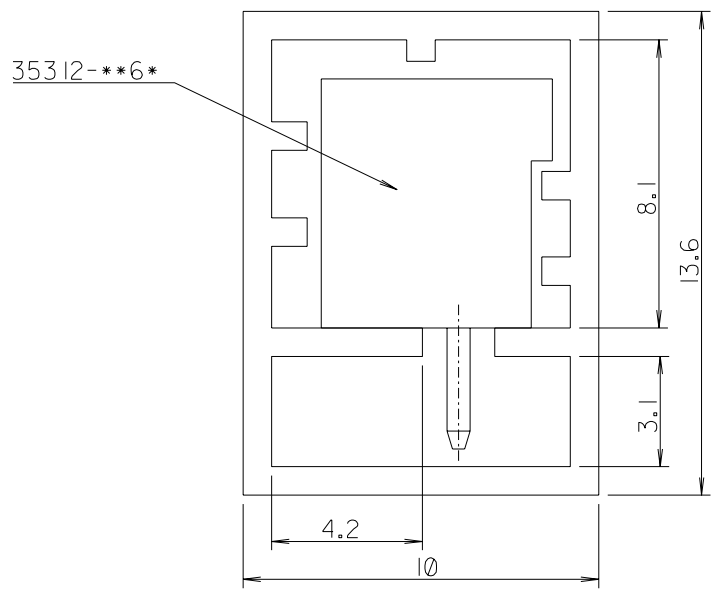

- NOTE
1. TUBE LENGTH : 550mm
 2. TUBE THICKNESS : 0.8mm
 3. THIS PRODUCT SHALL BE COMPLIED WITH RoHS COMPATIBLE(LEAD FREE SOLDERABILITY)

10	35312-1569	15	35312 SERIES
10	-1469	14	
10	-1369	13	
15	-1269	12	
15	-1169	11	
15	-1069	10	
20	-0969	9	
20	-0869	8	
25	-0769	7	
30	-0669	6	
35	-0569	5	
40	-0469	4	
50	-0369	3	
70	35312-0269	2	
Q'TY	ENG NO.	CKTS	

NEW RELEASED EC NO. KOR2005-0066 DRWN: K.S.KIM 041008 CHK: Y.Soo.KIM APPR: C.W.LEE	DESCRIPTION	QUALITY SYMBOLS	GENERAL TOLERANCES: (UNLESS SPECIFIED)		SCALE 5-1	DESIGN UNITS <input checked="" type="checkbox"/> mm <input type="checkbox"/> INCH	THIRD ANGLE PROJECTION	DIMENSIONS: <input type="checkbox"/> mm <input type="checkbox"/> INCH <input checked="" type="checkbox"/> mm ONLY		SHT	REV
		MAJOR =	CRITICAL =	mm	INCH	DRAWN BY & DATE H.S.SHIN		TITLE: TUBE PACKAGED FOR 35312 SERIES			
A	REV	4 PLACES	±0.	±.	CHECKED BY & DATE Y.Soo.KIM		MOLEX INCORPORATED				
		3 PLACES	±0.	±.	APPROVED BY & DATE C.W.LEE						
		2 PLACES	±0.	±.	CAD FILENAME		MATERIAL NO. 35312**69	DRAWING NO. SD-35312-005	SHEET NO. 1 OF 1	SIZE A	
		1 PLACE	±0.3	±.	ANGULAR: ± 2 °		THIS DRAWING CONTAINS INFORMATION THAT IS PROPRIETARY TO MOLEX INCORPORATED AND SHOULD NOT BE USED WITHOUT WRITTEN PERMISSION.				
		DRAFT WHERE APPLICABLE MUST REMAIN WITHIN DIMENSIONS									