



Pressure sensors

C28 series

Series/Type:	Gauge pressure sensor die for front side pressure applications
Ordering code:	
Date:	2009-08-03
Version:	3

Applications

- Medical devices
- Automotive
- Automation

Features

- Piezoresistive MEMS technology
- Small dimensions: 2.05 × 2.05 mm
- Square diaphragm
- Measured media (front side):
Dry non-aggressive gases.
Unsuitable for substances which react with glass, silicon or aluminum.
- Whetstone bridge with mV output, ratiometric to supply voltage
- Rated pressure ranges 1.6 up to 40 bar

Options

- Temperature sensing diode

Delivery mode

- Tray

Dimensional drawings

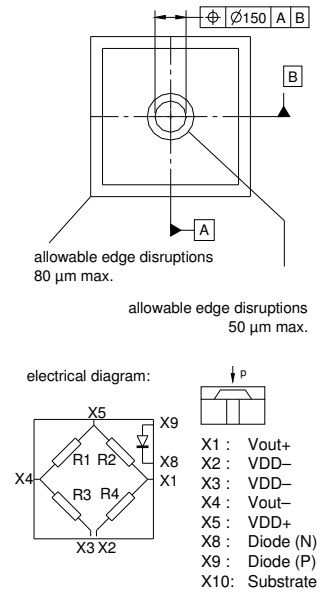
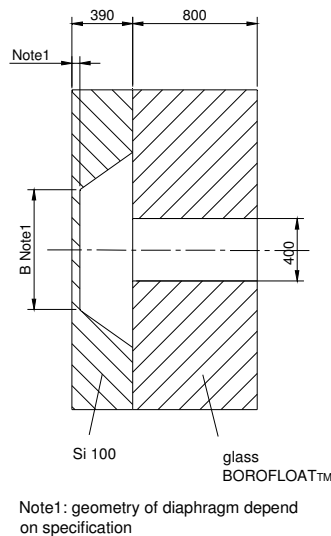
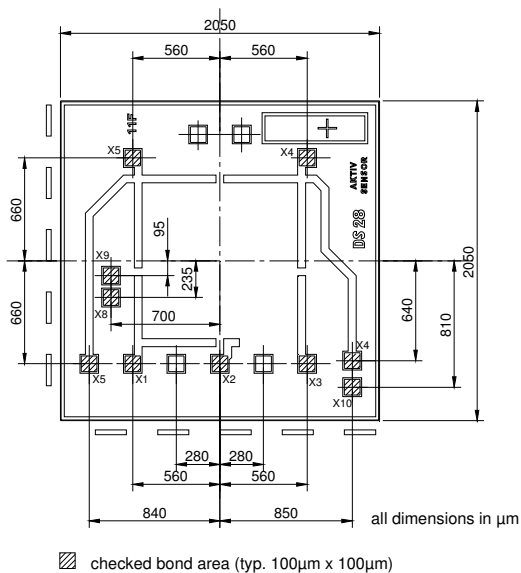

Pressure sensors
C28 series
Gauge pressure sensor die for front side pressure applications
Technical data
Absolute maximum ratings

Parameter	Symbol	Conditions	Min.	Typ.	Max.	Unit
Supply voltage						
Maximum supply voltage	V_{DD}	Without damage ¹⁾			10	V
Temperature ranges						
Operating temperature range	T_a	²⁾	-40		135	°C
		For $t < 15$ min	-40		140	°C
Storage temperature range	T_{st}	³⁾	-40		150	°C
Pressure ranges						
Operating pressure ranges	p_r	Gauge pressure ⁴⁾	0 ... 1.6		0 ... 40	bar
Over pressure	p_{ov}	Gauge pressure ⁵⁾	2.5			p_r
Burst pressure	p_{berst}	Gauge pressure ⁶⁾	3			p_r

Electrical specifications

Parameter	Symbol	Conditions	Min.	Typ.	Max.	Unit
Supply voltage / bridge resistance						
Operating supply voltage	V_{DD}	⁷⁾	1.0		5.0	V
Total bridge resistance	R_S	@ 25 °C ⁸⁾	2.7	3.2	3.7	k Ω
Temperature coefficient of total bridge resistance	α_{R_S}	@ 25 °C ⁹⁾	2.1	2.4	2.7	10 ⁻³ /K
	β_{R_S}		4	6	8	10 ⁻⁶ /K ²
Output signal @ $V_{DD} = 5$ V						
Offset	V_0	@ 25 °C ¹⁰⁾	-30	0	30	mV
Sensitivity	S	@ 25 °C ¹³⁾	See next table			mV/bar
Temperature coefficient of the sensitivity	α_S	@ 25 °C ¹⁵⁾	-2.5	-2.2	-1.9	10 ⁻³ /K
	β_S		3	5	8	10 ⁻⁶ /K ²
Pressure hysteresis	p_{Hys}	¹⁶⁾	-0.1		0.1	% FS
Optional temperature sensing diode						
Forward diode voltage	V_F	@ 25 °C, $I_F = 50 \mu A$ ¹⁷⁾	550	600	650	mV
Temperature coefficient of forward diode voltage	TCV_F	@ 25 °C, $I_F = 50 \mu A$ ¹⁸⁾	-2.4	-2.2	-2.0	mV/K
Long-term stability (Full scale normal output FSON = 120 mV)						
Temperature hysteresis of offset	THV_0	¹⁹⁾	-0.35	±0.2	0.35	% FSON
Temperature cycle drift of offset	$TCDV_0$	¹⁹⁾	-0.25	±0.1	0.25	% FSON
High temperature drift of offset	$HTDV_0$	¹⁹⁾	-0.25	±0.1	0.25	% FSON
Long term stability of offset	$LTSV_0$	¹⁹⁾	-0.45	±0.3	0.45	% FSON

Pressure sensors
C28 series
Gauge pressure sensor die for front side pressure applications
Operating pressures and ordering codes

Parameter @ 25 °C, V _{DD} = 5 V	Symbol	Typ.	Typ.	Typ.	Typ.	Units
Operating pressure ⁴⁾	p _r	2.5	6.0	10	25	bar
Temperature coefficient of offset voltage (unglued) ¹¹⁾ [min/typ/max]	TCV ₀ ⁻	-8/±4/8	-8/±4/8	-8/±4/8	-8/±4/8	µV/VK
	TCV ₀ ⁺	-4/±2/4	-4/±2/4	-4/±2/4	-4/±2/4	µV/VK
Nonlinearity ¹⁴⁾ [typ/max]	L	±0.2/±0.3	±0.2/±0.3	±0.2/±0.3	±0.2/±0.3	% FS
Sensitivity ¹³⁾ [min/typ/max]	S	36/48/60	15/20/25	9/12/15	3.6/4.8/6	mV/bar
Temperature sensing diode present		yes	yes	yes	yes	
Product type		AER -2.500 C28/1 G08 D	AER -6.000 C28/1 G08 D	AER -10.00 C28/1 G08 D	AER -25.00 C28/1 G08 D	
Ordering code		B58601D8010A024	B58601D8010A025	B58601D8010A026	B58601D8010A027	

Other operating pressures upon request.

Symbols and Terms

- 1) **Maximum power supply V_{DD}**
This is the maximal allowed voltage, which may be applied to the piezoresistive bridge circuit without damage.
- 2) **Operating temperature range T_a**
This is the operating Temperature range $T_{a,min}$ to $T_{a,max}$. Because most of the sensor parameters depend on assembling conditions like gluing, wire bonding etc, the die has to be tested over the operating temperature range by the customer fully assembled. For design verification and process control samples, mounted on a TO39 base are tested over a reduced measuring temperature range of $T_{meas,min}$ to $T_{meas,max}$.
- 3) **Storage temperature range T_{st}**
If the pressure sensor dies are stored in the temperature range $T_{st,min}$ to $T_{st,max}$ without applied voltage power supply, this will not affect the performance of the pressure sensor dies.
- 4) **Operating pressure range p_r**
In the operating pressure range 0 to $p_{r,max}$ the pressure sensor die output characteristic is as defined in this specification.
- 5) **Over pressure p_{ov}**
Pressure cycles in the pressure range 0 to p_{ov} do not affect the performance of the pressure sensor dies.
- 6) **Burst pressure p_{berst}**
Up to the burst pressure p_{berst} the diaphragm of the sensor die will not be destroyed mechanically. This parameter is tested at room temperature on samples mounted on an aluminium socket by increasing the applied pressure until the diaphragm is destroyed.
- 7) **Operating power supply V_{DD}**
The pressure sensor parameters are defined for a power supply voltage of $V_{DD} = 5\text{ V}$. In the operating power supply voltage range $V_{DD,min}$ to $V_{DD,max}$ the ratiometric parameters $r(V_{DD})$ like sensitivity, offset voltage and the temperature coefficient of the offset voltage are defined by:

$$r(V_{DD}) = r(5[V]) \frac{V_{DD}}{5[V]}$$

- 8) **Total bridge resistance R_S**
The total bridge resistance is defined between pad X5 and X2, X3 (see the dimensional drawing in this data sheet) of the closed piezoresistive bridge circuit. The total bridge resistance is in a good approximation the output impedance of the piezoresistive bridge circuit. This parameter is tested completely on a wafer (wafer level test measurement).
- 9) **Temperature coefficients of resistance α_{R_S} and β_{R_S} :**
The temperature coefficients of resistance are tested for design verification on samples, mounted on a TO39 base over a reduced temperature range $T_{meas,min} = -20\text{ °C}$ to $T_{meas,max} = 80\text{ °C}$ with $T_R = 25\text{ °C}$.
The temperature coefficients of first and second order are defined with the polynomial:

$$R_S(T) = R_S(T=25\text{°C}) \left[1 + \alpha_{R_S}(T-25\text{°C}) + \beta_{R_S}(T-25\text{°C})^2 \right]$$

The coefficients α_{R_S} and β_{R_S} are calculated using the three measurement points of $R_S(T)$ at $T_{meas,min}$, T_R and $T_{meas,max}$.

- 10) **Offset voltage V_0**
The offset voltage V_0 is the output voltage $V_{out}(p = 0\text{ bar gauge})$ at zero gauge pressure and for a bridge voltage power supply $V_{DD} = 5\text{ V}$. This parameter is tested completely on a wafer (wafer level test measurement).
It should be noted that this parameter may be influenced by assembly.
- 11) **Temperature coefficient of offset voltage TCV_0**
The temperature coefficients of offset voltage are defined for a bridge voltage power supply $V_{DD} = 5\text{ V}$.
These parameters strongly depend on assembly conditions like gluing, wire bonding etc.
The temperature coefficients of offset voltage are tested for design verification on samples, mounted on a TO39 base over a temperature range $T_{min} = -40\text{ °C}$ to $T_{max} = 135\text{ °C}$.
Therefore TCV_{0+} and TCV_{0-} are defined for the measurement temperature range by:

$$TCV_{0+} = \frac{V_0(T_{max}) - V_0(25\text{°C})}{T_{max} - 25\text{°C}} \quad TCV_{0-} = \frac{V_0(T_{min}) - V_0(25\text{°C})}{T_{min} - 25\text{°C}}$$

12) Full scale value FS

$$FS = V_{out}(p_{r,max}) - V_o$$

13) Sensitivity S

The sensitivity is defined for a bridge voltage power supply $V_{DD} = 5\text{ V}$. It can be determined by the formula:

$$S = \frac{V_{out}(p_{r,max}) - V_o}{p_{r,max}}$$

This parameter is tested for process control on samples, mounted on a TO39 base.

14) Nonlinearity L

This parameter may be influenced by assembly.

The nonlinearity is measured using the endpoint method. Assuming a characteristic, this can be approximated by a polynomial of second order, where the maximum is at $p_x = p_{r,max}/2$. The nonlinearity is defined at $p_x = p_{r,max}/2$, using the equation:

$$L = \frac{V_{out}(p_x) - V_o}{V_{out}(p_{r,max}) - V_o} - \frac{p_x}{p_{r,max}}$$

This parameter is tested for process control on samples, mounted on a TO39 base.

15) Temperature coefficient of sensitivity α_S and β_S :

These parameters may be influenced by assembly.

The temperature coefficients of sensitivity are tested for design verification on samples, mounted on a TO39 base over a reduced temperature range $T_{meas,min} = -20\text{ °C}$ to $T_{meas,max} = 80\text{ °C}$ with $T_R = 25\text{ °C}$.

The temperature coefficients of first and second order are defined with the polynomial:

$$S(T) = S(T=25\text{ °C}) \left[1 + \alpha_S(T-25\text{ °C}) + \beta_S(T-25\text{ °C})^2 \right]$$

The coefficients α_S and β_S are calculated using the three measurement points of $S(T)$ at $T_{meas,min}$, T_R and $T_{meas,max}$.

16) Pressure hysteresis pHys

The pressure hysteresis is the difference between output voltages at constant pressure and constant temperature while applying a pressure cycle with pressure steps of $p_{r,min}$, p_1 , p_2 , p_3 , $p_{r,max}$, p_3 , p_2 , p_1 , $p_{r,min}$:

$$pHys = \frac{V_{out,2}(p_k) - V_{out,1}(p_k)}{FS}$$

With $k = \text{min}, 1, 2, 3, \text{max}$. The pressure steps are: $p_{r,min} = 0$, $p_1 = 0.25 \cdot p_{r,max}$, $p_2 = 0.5 \cdot p_{r,max}$, $p_3 = 0.75 \cdot p_{r,max}$, $p_{r,max}$.

This parameter is tested for design verification on samples, mounted on a TO39 base.

17) Forward diode voltage V_F

The voltage drop is measured across anode and cathode by a forward current of $47\text{ }\mu\text{A}$.

This parameter is tested completely on a wafer (wafer level test measurement).

18) Temperature coefficient of forward diode voltage TCV_F

The temperature sensitivity of diode voltage drop is defined by the measured values at -20 °C and 80 °C using the equation:

$$TCV_F = \frac{V_F(T_{meas,max}) - V_F(T_{meas,min})}{T_{meas,max} - T_{meas,min}}$$

With $T_{meas,min} = -20\text{ °C}$ and $T_{meas,max} = 80\text{ °C}$ and the measurement is done with a constant current of $50\text{ }\mu\text{A}$.

The estimated temperature coefficient is also valid at temperatures between -40 °C and 135 °C .

This parameter is tested for design verification on samples, mounted on a TO39 base.

19) Reliability data

For long-term stability of offset voltage $LTSV_0$ please refer to the defined Aktiv Sensor's standard AS100001 in chapter "Reliability data" on the internet.

Cautions and warnings

Storage (general)

All pressure sensors should be stored in their original packaging. They should not be placed in harmful environments such as corrosive gases nor exposed to heat or direct sunlight, which may cause deformations. Similar effects may result from extreme storage temperatures and climatic conditions. Avoid storing the sensor dies in an environment where condensation may form or in a location exposed to corrosive gases, which will adversely affect their performance. Plastic materials should not be used for wrapping/packing when storing or transporting these dies, as they may become charged. Pressure sensor dies should be used soon after opening their seal and packaging.

Operation (general)

Media compatibility with the pressure sensors must be ensured to prevent their failure. The use of other media can cause damage and malfunction. Never use pressure sensors in atmospheres containing explosive liquids or gases.

Ensure pressure equalization to the environment, if gauge pressure sensors are used. Avoid operating the pressure sensors in an environment where condensation may form or in a location exposed to corrosive gases. These environments adversely affect their performance.

If the operating pressure is not within the rated pressure range, it may change the output characteristics. This may also happen with pressure sensor dies if an incorrect mounting method is used. Be sure that the applicable pressure does not exceed the overpressure, as it may damage the pressure sensor.

Do not exceed the maximum rated supply voltage nor the rated storage temperature range, as it may damage the pressure sensor.

Temperature variations in both the ambient conditions and the media (liquid or gas) can affect the accuracy of the output signal from the pressure sensors. Be sure to check the operating temperature range and thermal error specification of the pressure sensors to determine their suitability for the application.

Connections must be wired in accordance with the terminal assignment specified in the data sheets. Care should be taken as reversed pin connections can damage the pressure transmitters or degrade their performance. Contact between the pressure sensor terminals and metals or other materials may cause errors in the output characteristics.

Design notes (dies)

This specification describes the mechanical, electrical and physical requirements of a piezoresistive sensor die for measuring pressure. The specified parameters are valid for the pressure sensor die with pressure application either to the front or back side of the diaphragm as described in the data sheet. Pressure application to the other side may result in differing data. Most of the parameters are influenced by assembly conditions. Hence these parameters and the reliability have to be specified for each specific application and tested over its temperature range by the customer.

Handling/Mounting (dies)

Pressure sensor dies should be handled appropriately and not be touched with bare hands. They should only be picked up manually by the sides using tweezers. Their top surface should never be touched with tweezers. Latex gloves should not be used for handling them, as this will inhibit the curing of the adhesive used to bond the die to the carrier. When handling, be careful to avoid cuts caused by the sharp-edged terminals. The sensor die must not be contaminated during manufacturing processes (gluing, soldering, silk-screen process).

The package of pressure sensor dies should not to be opened until the die is mounted and should be closed after use. The sensor die must not be cleaned. The sensor die must not be damaged during the assembly process (especially scratches on the diaphragm).

Soldering (transducers, transmitters)

The thermal capacity of pressure sensors is normally low, so steps should be taken to minimize the effects of external heat. High temperatures may lead to damage or changes in characteristics.

A non-corrosive type of flux resin should normally be used and complete removal of the flux is recommended. Avoid rapid cooling due to dipping in solvent. Note that the output signal may change if pressure is applied to the terminals during soldering.

This listing does not claim to be complete, but merely reflects the experience of EPCOS AG.

Important notes

The following applies to all products named in this publication:

1. Some parts of this publication contain **statements about the suitability of our products for certain areas of application**. These statements are based on our knowledge of typical requirements that are often placed on our products in the areas of application concerned. We nevertheless expressly point out **that such statements cannot be regarded as binding statements about the suitability of our products for a particular customer application**. As a rule, EPCOS is either unfamiliar with individual customer applications or less familiar with them than the customers themselves. For these reasons, it is always ultimately incumbent on the customer to check and decide whether an EPCOS product with the properties described in the product specification is suitable for use in a particular customer application.
2. We also point out that **in individual cases, a malfunction of electronic components or failure before the end of their usual service life cannot be completely ruled out in the current state of the art, even if they are operated as specified**. In customer applications requiring a very high level of operational safety and especially in customer applications in which the malfunction or failure of an electronic component could endanger human life or health (e.g. in accident prevention or life-saving systems), it must therefore be ensured by means of suitable design of the customer application or other action taken by the customer (e.g. installation of protective circuitry or redundancy) that no injury or damage is sustained by third parties in the event of malfunction or failure of an electronic component.
3. **The warnings, cautions and product-specific notes must be observed.**
4. In order to satisfy certain technical requirements, **some of the products described in this publication may contain substances subject to restrictions in certain jurisdictions (e.g. because they are classed as hazardous)**. Useful information on this will be found in our Material Data Sheets on the Internet (www.epcos.com/material). Should you have any more detailed questions, please contact our sales offices.
5. We constantly strive to improve our products. Consequently, **the products described in this publication may change from time to time**. The same is true of the corresponding product specifications. Please check therefore to what extent product descriptions and specifications contained in this publication are still applicable before or when you place an order. We also **reserve the right to discontinue production and delivery of products**. Consequently, we cannot guarantee that all products named in this publication will always be available. The aforementioned does not apply in the case of individual agreements deviating from the foregoing for customer-specific products.
6. Unless otherwise agreed in individual contracts, **all orders are subject to the current version of the "General Terms of Delivery for Products and Services in the Electrical Industry" published by the German Electrical and Electronics Industry Association (ZVEI)**.
7. The trade names EPCOS, BAOKE, Alu-X, CeraDiode, CSMP, CSSP, CTVS, DSSP, MiniBlue, MiniCell, MKK, MLSC, MotorCap, PCC, PhaseCap, PhaseCube, PhaseMod, PhiCap, SIFERRIT, SIFI, SIKOREL, SilverCap, SIMDAD, SIMID, SineFormer, SIOV, SIP5D, SIP5K, ThermoFuse, WindCap are **trademarks registered or pending** in Europe and in other countries. Further information will be found on the Internet at www.epcos.com/trademarks.