



8 Channel Capacitive Touch Sensor with 2 LED Drivers

PRODUCT FEATURES

Datasheet

General Description

The CAP1028 is a multiple channel Capacitive Touch sensor with multiple power LED drivers. It contains eight (8) individual Capacitive Touch sensor inputs with programmable sensitivity for use in touch sensor applications. Each sensor automatically recalibrates to compensate for gradual environmental changes.

The CAP1028 also contains two (2) LED drivers that offer full-on / off, variable rate blinking, dimness controls, and breathing. Each of the LED drivers may be linked to one of the sensors to be actuated when a touch is detected. As well, each LED driver may be individually controlled via a host controller.

The CAP1028 offers multiple power states operating at low quiescent currents.

During the Standby mode of operation, one or more Capacitive Touch Sensors are active and all LEDs may be used. If a touch is detected, then it will wake the system using the WAKE/SPI_MOSI pin.

The Deep Sleep mode of operation is the lowest power state available drawing 3uA of current. During this mode, no sensors are active though all LEDs may be used. Driving the WAKE/SPI_MOSI pin or communications will wake the device.

Applications

- Desktop and Notebook PC's
- LCD Monitors
- Printers
- Appliances

Features

- Eight (8) Capacitive Touch Sensor Inputs
 - Programmable sensitivity
 - Automatic recalibration
 - Individual thresholds for each button
- Flexible Capacitive Touch Sense algorithm
- Multiple Communication interfaces
 - SMBus / I²C compliant interface
 - SMSC BC-Link interface
 - SPI communications
 - Pin selectable communications protocol and multiple slave addresses (SMBus / I²C only)
- Low Power operation
 - 3uA quiescent current in Deep Sleep
 - Samples one or more channels in Standby
- Two (2) LED Driver Outputs
 - Open Drain or Push-Pull
 - Programmable blink, breathe, and dimness controls
 - Can be linked to Capacitive Touch Sensors
- Dedicated Wake output flags touches in low power mode
- System RESET pin
- Available in 20-pin 4mm x 4mm RoHS compliant QFN package

Block Diagram

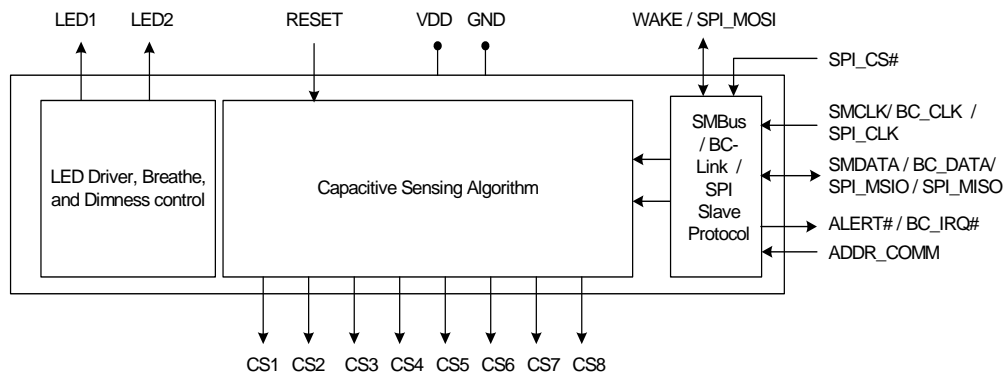

Note: I²C is a trademark of NXP semiconductor. BC-Link is a trademark of SMSC.

ORDERING INFORMATION

ORDERING NUMBER	PACKAGE	FEATURES
CAP1028-1-BP-TR	20-pin QFN 4mm x 4mm (Lead Free RoHS compliant)	Eight Capacitive Touch Sensors, Two LED drivers, Dedicated Wake, Reset, SMBus / BC-Link / SPI interfaces

REEL SIZE IS 4,000 PIECES

80 ARKAY DRIVE, HAUPPAUGE, NY 11788 (631) 435-6000, FAX (631) 273-3123

Copyright © 2009 SMSC or its subsidiaries. All rights reserved.

Circuit diagrams and other information relating to SMSC products are included as a means of illustrating typical applications. Consequently, complete information sufficient for construction purposes is not necessarily given. Although the information has been checked and is believed to be accurate, no responsibility is assumed for inaccuracies. SMSC reserves the right to make changes to specifications and product descriptions at any time without notice. Contact your local SMSC sales office to obtain the latest specifications before placing your product order. The provision of this information does not convey to the purchaser of the described semiconductor devices any licenses under any patent rights or other intellectual property rights of SMSC or others. All sales are expressly conditional on your agreement to the terms and conditions of the most recently dated version of SMSC's standard Terms of Sale Agreement dated before the date of your order (the "Terms of Sale Agreement"). The product may contain design defects or errors known as anomalies which may cause the product's functions to deviate from published specifications. Anomaly sheets are available upon request. SMSC products are not designed, intended, authorized or warranted for use in any life support or other application where product failure could cause or contribute to personal injury or severe property damage. Any and all such uses without prior written approval of an Officer of SMSC and further testing and/or modification will be fully at the risk of the customer. Copies of this document or other SMSC literature, as well as the Terms of Sale Agreement, may be obtained by visiting SMSC's website at <http://www.smisc.com>. SMSC is a registered trademark of Standard Microsystems Corporation ("SMSC"). Product names and company names are the trademarks of their respective holders.

SMSC DISCLAIMS AND EXCLUDES ANY AND ALL WARRANTIES, INCLUDING WITHOUT LIMITATION ANY AND ALL IMPLIED WARRANTIES OF MERCHANTABILITY, FITNESS FOR A PARTICULAR PURPOSE, TITLE, AND AGAINST INFRINGEMENT AND THE LIKE, AND ANY AND ALL WARRANTIES ARISING FROM ANY COURSE OF DEALING OR USAGE OF TRADE. IN NO EVENT SHALL SMSC BE LIABLE FOR ANY DIRECT, INCIDENTAL, INDIRECT, SPECIAL, PUNITIVE, OR CONSEQUENTIAL DAMAGES; OR FOR LOST DATA, PROFITS, SAVINGS OR REVENUES OF ANY KIND; REGARDLESS OF THE FORM OF ACTION, WHETHER BASED ON CONTRACT; TORT; NEGLIGENCE OF SMSC OR OTHERS; STRICT LIABILITY; BREACH OF WARRANTY; OR OTHERWISE; WHETHER OR NOT ANY REMEDY OF BUYER IS HELD TO HAVE FAILED OF ITS ESSENTIAL PURPOSE, AND WHETHER OR NOT SMSC HAS BEEN ADVISED OF THE POSSIBILITY OF SUCH DAMAGES.

Table of Contents

Chapter 1	Pin Description	8
Chapter 2	Electrical Specifications	11
Chapter 3	Communications	15
3.1	Communications	15
3.1.1	SMBus (I ² C) Communications	15
3.1.2	SPI Communications	15
3.1.3	BC-Link Communications	15
3.2	System Management Bus	16
3.2.1	SMBus Start Bit	16
3.2.2	SMBus Address and RD / WR Bit	16
3.2.3	SMBus Data Bytes	16
3.2.4	SMBus ACK and NACK Bits	16
3.2.5	SMBus Stop Bit	17
3.2.6	SMBus Timeout	17
3.2.7	SMBus and I ² C Compliance	17
3.3	SMBus Protocols	17
3.3.1	SMBus Write Byte	17
3.3.2	Block Write	18
3.3.3	SMBus Read Byte	18
3.3.4	Block Read	18
3.3.5	SMBus Send Byte	18
3.3.6	SMBus Receive Byte	19
3.4	SPI Interface	19
3.4.1	SPI Normal Mode	20
3.4.2	SPI Bi-Directional Mode	20
3.4.3	SPI_CS# Pin	20
3.4.4	Address Pointer	20
3.4.5	SPI Timeout	20
3.5	Normal SPI Protocols	20
3.5.1	Reset Interface	21
3.5.2	Set Address Pointer	22
3.5.3	Write Data	22
3.5.4	Read Data	23
3.6	Bi-Directional SPI Protocols	24
3.6.1	Reset Interface	24
3.6.2	Set Address Pointer	24
3.6.3	Write Data	25
3.6.4	Read Data	25
3.7	BC-Link Interface	25
Chapter 4	General Description	27
4.1	Power States	28
4.2	RESET Pin	29
4.3	WAKE/SPI_MOSI Pin Operation	29
4.4	LED Drivers	29
4.4.1	Linking LEDs to Capacitive Touch Sensors	30
4.5	Capacitive Touch Sensing	30
4.5.1	Sensing Cycle	30
4.5.2	Recalibrating Sensors	30

4.6	ALERT# Pin	30
4.6.1	Sensor Interrupt Behavior	30

Chapter 5 Register Description **32**

5.1	Main Status Control Register	35
5.2	Status Registers	36
5.2.1	Sensor Status	36
5.2.2	LED Status	36
5.3	Noise Flag Status Registers	37
5.4	Sensor Delta Count Registers	37
5.5	Sensitivity Control Register	38
5.6	Configuration Register	39
5.7	Sensor Enable Registers	40
5.8	Sensor Configuration Register	40
5.9	Sensor Configuration 2 Register	42
5.10	Averaging and Sampling Configuration Register	42
5.11	Calibration Activate Registers	44
5.12	Interrupt Enable Register	44
5.13	Repeat Rate Enable Register	45
5.14	Multiple Touch Configuration Register	46
5.15	Recalibration Configuration Register	46
5.16	Sensor Threshold Registers	48
5.17	Sensor Noise Threshold Registers	48
5.17.1	Sensor Noise Threshold 1 Register	49
5.17.2	Sensor Noise Threshold 2 Register	49
5.18	Standby Channel Register	49
5.19	Standby Configuration Register	50
5.20	Standby Sensitivity Register	51
5.21	Standby Threshold Register	52
5.22	Sensor Base Count Registers	52
5.23	LED Output Type Register	53
5.24	Sensor LED Linking Register	53
5.25	LED Polarity Register	54
5.26	LED Output Control Register	55
5.27	LED Behavior Registers	56
5.28	LED Pulse 1 Period Register	57
5.29	LED Pulse 2 Period Register	59
5.30	LED Breathe Period Register	60
5.31	LED Configuration Register	61
5.32	LED Duty Cycle Registers	62
5.33	LED Direct Ramp Rates Register	63
5.34	LED Off Delay Register	64
5.35	Product ID Register	65
5.36	Manufacturer ID Register	65
5.37	Revision Register	65

Chapter 6 Package Information **66**

6.1	CAP1028 Package Drawings	66
6.2	Package Marking	68

Chapter 7 Revision History **69**

List of Figures

Figure 1.1	CAP1028 Pin Diagram (20-Pin QFN)	8
Figure 3.1	SMBus Timing Diagram	16
Figure 3.1	SPI Timing	19
Figure 3.1	Example SPI Bus Communication - Normal Mode	21
Figure 3.2	SPI Reset Interface Command - Normal Mode	22
Figure 3.3	SPI Set Address Pointer Command - Normal Mode	22
Figure 3.4	SPI Write Command - Normal Mode	23
Figure 3.5	SPI Read Command - Normal Mode	23
Figure 3.6	SPI Read Command - Normal Mode - Full	24
Figure 3.7	SPI Reset Interface Command - Bi-directional Mode	24
Figure 3.8	SPI Set Address Pointer Command - Bi-directional Mode	25
Figure 3.9	SPI Write Data Command - Bi-directional Mode	25
Figure 3.10	SPI Read Data Command - Bi-directional Mode	25
Figure 4.1	System Diagram for CAP1028	28
Figure 4.2	Sensor Interrupt Behavior - Repeat Rate Enabled	31
Figure 4.3	Sensor Interrupt Behavior - No Repeat Rate Enabled	31
Figure 5.1	Pulse Behavior with Non-Inverted Polarity	58
Figure 5.2	Pulse Behavior with Inverted Polarity	58
Figure 5.3	Pulse 2 Behavior with Non-Inverted Polarity	60
Figure 5.4	Pulse 2 Behavior with Inverted Polarity	60
Figure 5.5	Direct Mode Behavior for Non-Inverted Polarity	64
Figure 5.6	Direct Mode Behavior for Inverted Polarity	65
Figure 6.1	20-Pin QFN 4mm x 4mm Package Drawing	66
Figure 6.2	20-Pin QFN 4mm x 4mm Package Dimensions	67
Figure 6.3	20-Pin QFN 4mm x 4mm PCB Drawing	67
Figure 6.4	CAP1028 Package Markings	68

List of Tables

Table 1.1	Pin Description for CAP1028	8
Table 1.2	Pin Types	10
Table 2.1	Absolute Maximum Ratings	11
Table 2.2	Electrical Specifications	11
Table 3.1	ADDR_COMM Pin Decode	15
Table 3.2	Protocol Format	17
Table 3.3	Write Byte Protocol	17
Table 3.4	Block Write Protocol	18
Table 3.5	Read Byte Protocol	18
Table 3.6	Block Read Protocol	18
Table 3.7	Send Byte Protocol	19
Table 3.8	Receive Byte Protocol	19
Table 5.1	Register Set in Hexadecimal Order	32
Table 5.2	Main Status Control Register	35
Table 5.3	Status Registers	36
Table 5.4	Noise Flag Status Registers	37
Table 5.5	Sensor Delta Count Registers	37
Table 5.6	Sensitivity Control Register	38
Table 5.7	DELTA_SENSE Bit Decode	38
Table 5.8	BASE_SHIFT Bit Decode	39
Table 5.9	Configuration Register	39
Table 5.10	Sensor Enable Registers	40
Table 5.11	Sensor Configuration Register	40
Table 5.12	MAX_DUR Bit Decode	41
Table 5.13	RPT_RATE Bit Decode	41
Table 5.14	Sensor Configuration 2 Register	42
Table 5.15	Averaging and Sampling Configuration Register	42
Table 5.16	AVG Bit Decode	43
Table 5.17	CYCLE_TIME Bit Decode	43
Table 5.18	Calibration Activate Registers	44
Table 5.19	Interrupt Enable Register	44
Table 5.20	Repeat Rate Enable Register	45
Table 5.21	Multiple Touch Configuration	46
Table 5.22	B_MULT_T Bit Decode	46
Table 5.23	Recalibration Configuration Registers	46
Table 5.24	NEG_DELTA_CNT Bit Decode	47
Table 5.25	CAL_CFG Bit Decode	47
Table 5.26	Sensor Threshold Registers	48
Table 5.27	Sensor Noise Threshold Registers	48
Table 5.28	CSx_BN_TH Bit Decode	49
Table 5.29	Standby Channel Register	49
Table 5.30	Standby Configuration Register	50
Table 5.31	STBY_AVG Bit Decode	50
Table 5.32	STBY_CY_TIME Bit Decode	51
Table 5.33	Standby Configuration Register	51
Table 5.34	STBY_SENSE Bit Decode	52
Table 5.35	Standby Threshold Register	52
Table 5.36	Sensor Base Count Registers	52
Table 5.37	LED Output Type Register	53
Table 5.38	Sensor LED Linking Register	53
Table 5.39	LED Polarity Register	54
Table 5.40	LED Output Control Register	55

**Datasheet**

Table 5.41 LED Polarity Behavior	55
Table 5.42 LED Behavior Registers	56
Table 5.43 LEDx_CTL Bit Decode.	57
Table 5.44 LED Pulse 1 Period Register.	57
Table 5.45 LED Pulse / Breathe Period Example	59
Table 5.46 LED Pulse 2 Period Register.	59
Table 5.47 LED Breathe Period Register	60
Table 5.48 LED Configuration Register.	61
Table 5.49 PULSEX_CNT Decode	61
Table 5.50 LED Duty Cycle Registers	62
Table 5.51 LED Duty Cycle Decode	62
Table 5.52 LED Direct Ramp Rates Register	63
Table 5.53 Rise / Fall Rate and Off Delay Decode	63
Table 5.54 LED Off Delay Register	64
Table 5.55 Product ID Register	65
Table 5.56 Vendor ID Register	65
Table 5.57 Revision Register.	65
Table 7.1 Customer Revision History	69

Chapter 1 Pin Description

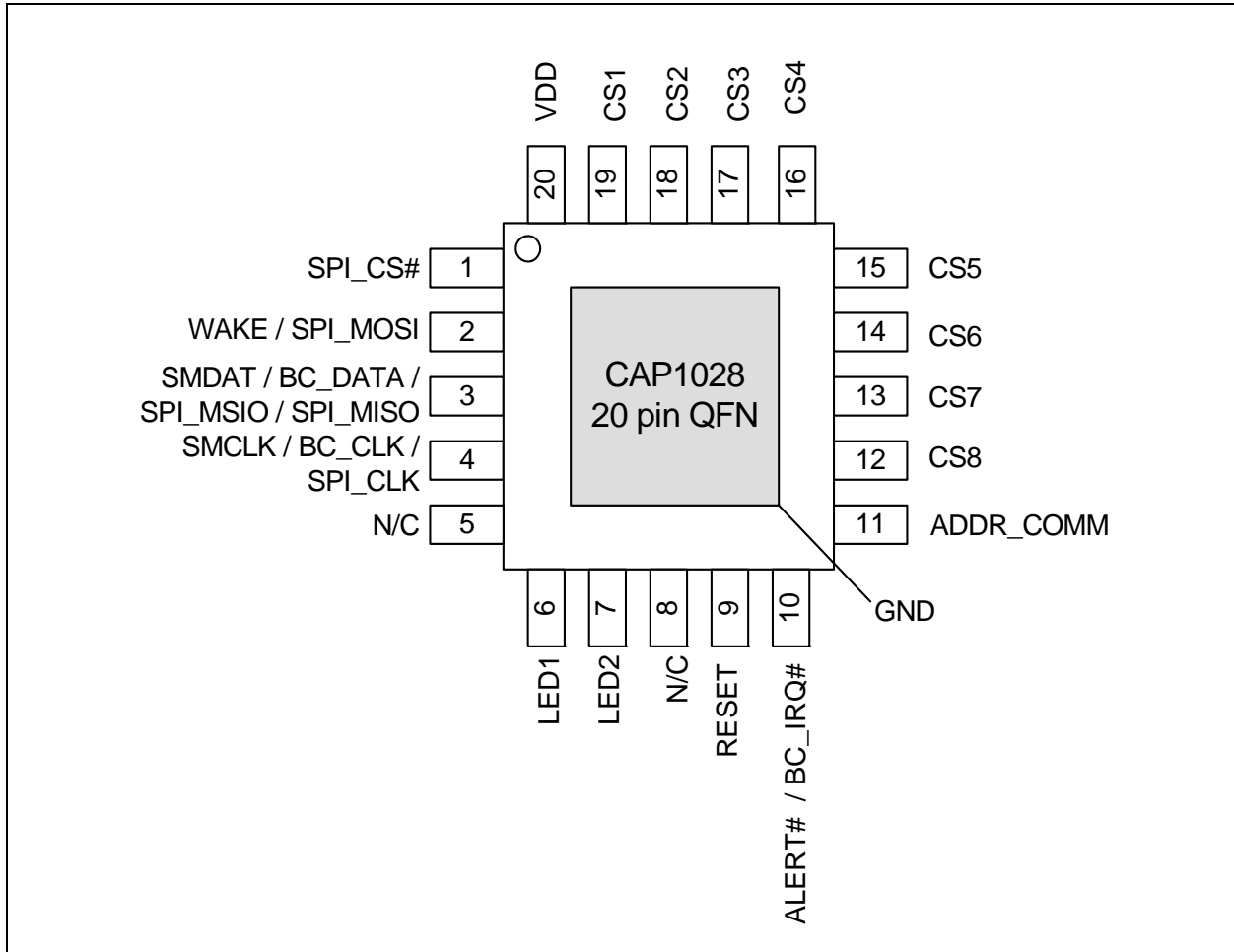

Figure 1.1 CAP1028 Pin Diagram (20-Pin QFN)

Table 1.1 Pin Description for CAP1028

PIN NUMBER	PIN NAME	PIN FUNCTION	PIN TYPE
1	SPI_CS#	Active low chip-select for SPI bus	DI (5V)
2	WAKE / SPI_MOSI	WAKE - Active high wake / interrupt output Standby power state	DO
		WAKE - Active high wake input - requires pull-down resistor Deep Sleep power state	DI
		SPI_MOSI - SPI Master-Out-Slave-In port when used in normal mode	DI (5V)

Table 1.1 Pin Description for CAP1028 (continued)

PIN NUMBER	PIN NAME	PIN FUNCTION	PIN TYPE
3	SMDATA / BC_DATA / SPI_MSIO / SPI_MISO	SMDATA - Bi-directional, open-drain SMBus data - requires pull-up resistor	DIOD (5V)
		BC_DATA - Bi-directional, open-drain BC-Link data - requires pull-up resistor	DIO
		SPI_MSIO - SPI Master-Slave-In-Out bidirectional port when used in bi-directional mode	DIO
		SPI_MISO - SPI Master-In-Slave-Out port when used in normal mode	DO
4	SMCLK / BC_CLK / SPI_CLK	SMCLK - SMBus clock input - requires pull-up resistor	DI (5V)
		BC_CLK - BC-Link clock input	DI (5V)
		SPI_CLK - SPI clock input	DI (5V)
5	N/C	Not Internally Connected	n/a
6	LED1	Open drain LED 1 driver (default)	OD (5V)
		Push-pull LED 1 driver	DO
7	LED2	Open drain LED 2 driver (default)	OD (5V)
		Push-pull LED 2 driver	DO
8	N/C	Not Internally Connected	n/a
9	RESET	Active high soft reset for system - resets all registers to default values. This pin contains an internal 50uA pull-down current.	DI (5V)
10	ALERT# / BC_IRQ#	ALERT# - Active low alert / interrupt output usable for SMBus alert or SPI interrupt	OD (5V)
		BC_IRQ# - Active low interrupt / optional for BC-Link	OD (5V)
11	ADDR_COMM	Address / communications select pin - pull-down resistor determines address / communications mechanism	AI
12	CS8	Capacitive Touch Sensor 8	AIO
13	CS7	Capacitive Touch Sensor 7	AIO
14	CS6	Capacitive Touch Sensor 6	AIO
15	CS5	Capacitive Touch Sensor 5	AIO
16	CS4	Capacitive Touch Sensor 4	AIO
17	CS3	Capacitive Touch Sensor 3	AIO
18	CS2	Capacitive Touch Sensor 2	AIO
19	CS1	Capacitive Touch Sensor 1	AIO
20	VDD	Positive Power supply	Power
Bottom Pad	GND	Ground	Power

The pin types are described in detail below. All pins labeled with (5V) are 5V tolerant.

APPLICATION NOTE: For the 5V tolerant pins that have a pull-up resistor, the pull-up voltage must not exceed 3.6V when the CAP1028 is unpowered.

APPLICATION NOTE: The SPI_CS# pin should be grounded when SMBus, I²C, or BC-Link communications are used.

Table 1.2 Pin Types

PIN TYPE	DESCRIPTION
Power	This pin is used to supply power or ground to the device.
DI	Digital Input - This pin is used as a digital input. This pin is 5V tolerant.
AIO	Analog Input / Output -This pin is used as an I/O for analog signals.
DIOD	Digital Input / Open Drain Output- This pin is used as a digital I/O. When it is used as an output, it is open drain and requires a pull-up resistor. This pin is 5V tolerant.
OD	Open Drain Digital Output - this pin is used as a digital output. It is open drain and requires a pull-up resistor. This pin is 5V tolerant.
DO	Push-pull Digital Output - This pin is used as a digital output and can sink and source current.
DIO	Push-pull Digital Input / Output - This pin is used as an I/O for digital signals.

Chapter 2 Electrical Specifications

Table 2.1 Absolute Maximum Ratings

Voltage on 5V tolerant pins (V_{5VT_PIN})	-0.3 to 5.5	V
Voltage on 5V tolerant pins ($ V_{5VT_PIN} - V_{DD} $) Note 2.2	0 to 3.6	V
Voltage on VDD pin	-0.3 to 4	V
Voltage on any other pin to GND	-0.3 to $V_{DD} + 0.3$	V
Package Power Dissipation up to $T_A = 85^\circ\text{C}$ for 20 pin QFN (see Note 2.3)	0.9	W
Junction to Ambient (θ_{JA}) (see Note 2.4)	58	$^\circ\text{C}/\text{W}$
Operating Ambient Temperature Range	-40 to 125	$^\circ\text{C}$
Storage Temperature Range	-55 to 150	$^\circ\text{C}$
ESD Rating, All Pins, HBM	8000	V

Note 2.1 Stresses above those listed could cause permanent damage to the device. This is a stress rating only and functional operation of the device at any other condition above those indicated in the operation sections of this specification is not implied.

Note 2.2 For the 5V tolerant pins that have a pull-up resistor, the voltage difference between V_{5VT_PIN} and V_{DD} must never exceed 3.6V.

Note 2.3 The Package Power Dissipation specification assumes a recommended thermal via design consisting of a 3x3 matrix of 0.3mm (12mil) vias at 1.0mm pitch connected to the ground plane with a 2.5 x 2.5mm thermal landing.

Note 2.4 Junction to Ambient (θ_{JA}) is dependent on the design of the thermal vias. Without thermal vias and a thermal landing, the θ_{JA} is approximately $60^\circ\text{C}/\text{W}$ including localized PCB temperature increase.

Table 2.2 Electrical Specifications

$V_{DD} = 3\text{V to } 3.6\text{V}$, $T_A = 0^\circ\text{C to } 100^\circ\text{C}$, all Typical values at $T_A = 27^\circ\text{C}$ unless otherwise noted.						
CHARACTERISTIC	SYMBOL	MIN	TYP	MAX	UNIT	CONDITIONS
DC Power						
Supply Voltage	V_{DD}	3.0	3.3	3.6	V	

Table 2.2 Electrical Specifications (continued)

V _{DD} = 3V to 3.6V, T _A = 0°C to 100°C, all Typical values at T _A = 27°C unless otherwise noted.						
CHARACTERISTIC	SYMBOL	MIN	TYP	MAX	UNIT	CONDITIONS
Supply Current	I _{STBY}		160	210	uA	Standby state active 1 sensor monitored No LED active Default conditions (8 avg, 70ms cycle time)
	I _{DSLEEP}		3	10	uA	Deep Sleep state active LEDs at 100% or 0% Duty Cycle No communications T _A < 85°C
	I _{DD}		300	500	uA	Average current Capacitive Sensing Active LEDs enabled
Capacitive Touch Sensor						
Maximum Base Capacitance	C _{BASE}		50		pF	Pad untouched
Detectable Capacitive Shift	ΔC _{TOUCH}	0.1		2	pF	Pad touched
LED Drivers						
Duty Cycle	DUTY _{LED}	0		100	%	Programmable
Sinking Current	I _{SINK}			24	mA	V _{OL} = 0.4
Sourcing Current	I _{SOURCE}			24	mA	V _{OH} = V _{DD} - 0.4
I/O Pins - SPI_CS#, RESET, WAKE / SPI_MOSI, and ALERT# pins						
Output Low Voltage	V _{OL}			0.4	V	I _{SINK_IO} = 4mA
Output High Voltage	V _{OH}	V _{DD} - 0.4			V	WAKE pin only I _{SOURCE_IO} = 4mA
Input High Voltage	V _{IH}	2.0			V	
Input Low Voltage	V _{IL}			0.8	V	
Leakage Current	I _{LEAK}			±5	uA	powered or unpowered T _A < 85°C
SMDATA / BC_DATA / SPI_MSIO / SPI_MISO and SMCLK / BC_CLK / SPI_CLK pins						
Output Low Voltage	V _{OL}			0.4	V	I _{SINK_IO} = 8mA
Output High Voltage	V _{OH}	V _{DD} - 0.4			V	I _{SOURCE_IO} = 8mA
Input High Voltage	V _{IH}	2.0			V	
Input Low Voltage	V _{IL}			0.8	V	
Leakage Current	I _{LEAK}			±5	uA	powered or unpowered T _A < 85°C pull-up voltage ≤ 3.6V

Datasheet

Table 2.2 Electrical Specifications (continued)

V _{DD} = 3V to 3.6V, T _A = 0°C to 100°C, all Typical values at T _A = 27°C unless otherwise noted.						
CHARACTERISTIC	SYMBOL	MIN	TYP	MAX	UNIT	CONDITIONS
SMBus First Communication	t _{SMB}			15	ms	
SMBus Timing						
Input Capacitance	C _{IN}		5		pF	
Clock Frequency	f _{SMB}	10		400	kHz	
Spike Suppression	t _{SP}			50	ns	
Bus free time Start to Stop	t _{BUF}	1.3			us	
Setup Time: Start	t _{SU:STA}	0.6			us	
Setup Time: Stop	t _{SU:STP}	0.6			us	
Data Hold Time	t _{HD:DAT}	0.6		6	us	
Data Setup Time	t _{SU:DAT}	0.6		72	us	
Clock Low Period	t _{LOW}	1.3			us	
Clock High Period	t _{HIGH}	0.6			us	
Clock/Data Fall time	t _{FALL}			300	ns	Min = 20+0.1C _{LOAD} ns
Clock/Data Rise time	t _{RISE}			300	ns	Min = 20+0.1C _{LOAD} ns
Capacitive Load	C _{LOAD}			400	pF	per bus line
BC-Link Timing						
Clock Period	t _{CLK}	250			ns	
Data Hold Time	t _{HD:DAT}	0			ns	
Data Setup Time	t _{SU:DAT}	30			ns	Data must be valid before clock
Clock Duty Cycle	Duty	40	50	60	%	
SPI Timing						
Clock Period	t _p	250			ns	
Clock Low Period	t _{LOW}	0.4 x t _p		0.6 x t _p	ns	
Clock High Period	t _{HIGH}	0.4 x t _p		0.6 x t _p	ns	
Clock Rise / Fall time	t _{RISE} / t _{FALL}			0.1 x t _p	ns	
Data Output Delay	t _{D:CLK}			10	ns	
Data Setup Time	t _{SU:DAT}	20			ns	
Data Hold Time	t _{HD:DAT}	20			ns	

Table 2.2 Electrical Specifications (continued)

V _{DD} = 3V to 3.6V, T _A = 0°C to 100°C, all Typical values at T _A = 27°C unless otherwise noted.						
CHARACTERISTIC	SYMBOL	MIN	TYP	MAX	UNIT	CONDITIONS
SPI_CS# to SPI_CLK setup time	t _{SU:CS}	0			ns	
Wake Time	t _{WAKE}	10		20	us	SPI_CS# asserted to CLK assert

Chapter 3 Communications

3.1 Communications

The CAP1028 communicates using the 2-wire SMBus or I²C bus, the 2-wire proprietary BC-Link, or the SPI bus. Regardless of communication mechanism, the device functionality remains unchanged. The communications mechanism as well as the SMBus (or I²C) slave address is determined by the resistor connected between the ADDR_COMM pin and ground as shown in [Table 3.1](#).

Table 3.1 ADDR_COMM Pin Decode

PULL-DOWN RESISTOR (+/- 5%)	PROTOCOL USED	SMBUS ADDRESS
<= 47k	SPI Communications using Normal 4-wire Protocol Used	n/a
56k	SPI Communications using Bi-Directional 3-wire Protocol Used	n/a
68k	BC-Link Communications	n/a
82k	SMBus / I ² C	0101_100(r/w)
100k	SMBus / I ² C	0101_011(r/w)
120k	SMBus / I ² C	0101_010(r/w)
150k	SMBus / I ² C	0101_001(r/w)
VDD	SMBus / I ² C	0101_000(r/w)

3.1.1 SMBus (I²C) Communications

When configured to communicate via the SMBus, the CAP1028 supports the following protocols: Send Byte, Receive Byte, Read Byte, and Write Byte. In addition, the device supports I²C formatting for block read and block write protocols.

APPLICATION NOTE: For SMBus/I²C communications, the SPI_CS# pin is not used and should be grounded; any data presented to this pin will be ignored.

See [Section 3.2](#) and [Section 3.3](#) for more information on the SMBus bus and protocols respectively.

3.1.2 SPI Communications

When configured to communicate via the SPI bus, the CAP1028 supports both bi-directional 3-wire and normal 4-wire protocols and uses the SPI_CS# pin to enable communications.

See [Section 3.4](#) and [Section 3.5](#) for more information on the SPI bus and protocols respectively.

3.1.3 BC-Link Communications

When BC-Link communications are used, the CAP1028 supports the read byte protocol and the write byte protocol.

APPLICATION NOTE: For BC-Link communications, the SPI_CS# pin is not used and should be grounded; any data presented to this pin will be ignored.

See [Section 3.7](#) for more information on the BC-Link Bus and protocols respectively.

APPLICATION NOTE: Upon power up, the CAP1028 will not respond to any communications for up to 15ms. After this time, full functionality is available.

3.2 System Management Bus

The CAP1028 communicates with a host controller, such as an SMSC SIO, through the SMBus. The SMBus is a two-wire serial communication protocol between a computer host and its peripheral devices. A detailed timing diagram is shown in [Figure 3.1](#). Stretching of the SMCLK signal is supported; however, the CAP1028 will not stretch the clock signal.

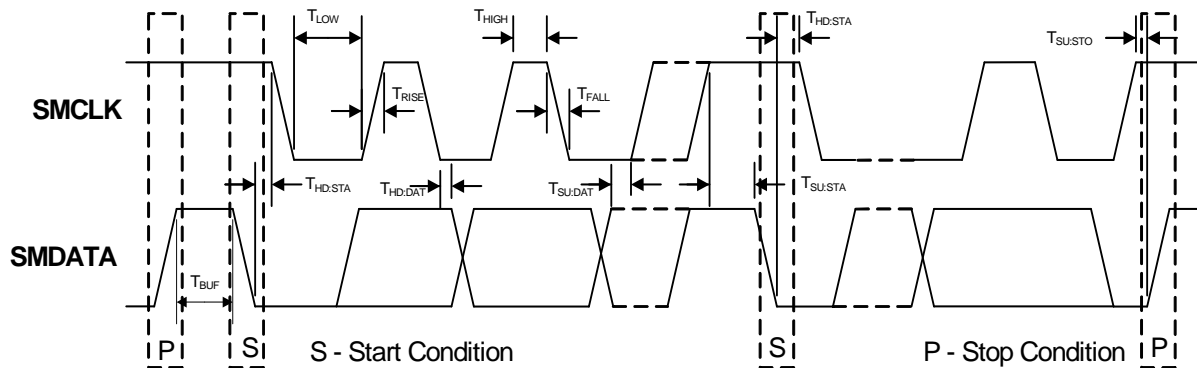

Figure 3.1 SMBus Timing Diagram

3.2.1 SMBus Start Bit

The SMBus Start bit is defined as a transition of the SMBus Data line from a logic '1' state to a logic '0' state while the SMBus Clock line is in a logic '1' state.

3.2.2 SMBus Address and RD / $\overline{\text{WR}}$ Bit

The SMBus Address Byte consists of the 7-bit client address followed by the RD / $\overline{\text{WR}}$ indicator bit. If this RD / $\overline{\text{WR}}$ bit is a logic '0', then the SMBus Host is writing data to the client device. If this RD / $\overline{\text{WR}}$ bit is a logic '1', then the SMBus Host is reading data from the client device.

See [Table 3.1](#) for available SMBus addresses.

3.2.3 SMBus Data Bytes

All SMBus Data bytes are sent most significant bit first and composed of 8-bits of information.

3.2.4 SMBus ACK and NACK Bits

The SMBus client will acknowledge all data bytes that it receives. This is done by the client device pulling the SMBus Data line low after the 8th bit of each byte that is transmitted. This applies to both the Write Byte and Block Write protocols.

The Host will NACK (not acknowledge) the last data byte to be received from the client by holding the SMBus data line high after the 8th data bit has been sent. For the Block Read protocol, the Host will ACK each data byte that it receives except the last data byte.

Datasheet

3.2.5 SMBus Stop Bit

The SMBus Stop bit is defined as a transition of the SMBus Data line from a logic '0' state to a logic '1' state while the SMBus clock line is in a logic '1' state. When the CAP1028 detects an SMBus Stop bit, and it has been communicating with the SMBus protocol, it will reset its client interface and prepare to receive further communications.

3.2.6 SMBus Timeout

The CAP1028 includes an SMBus timeout feature. Following a 30ms period of inactivity on the SMBus where the SMCLK pin is held low, the device will timeout and reset the SMBus interface.

The timeout function defaults to disabled. It can be enabled by setting the TIMEOUT bit in the Configuration register (see [Section 5.6](#)).

3.2.7 SMBus and I²C Compliance

The major difference between SMBus and I²C devices is highlighted here. For complete compliance information refer to the SMBus 2.0 specification.

1. Minimum frequency for SMBus communications is 10kHz.
2. The client protocol will reset if the clock is held low longer than 30ms.
3. The client protocol will reset if both the clock and the data line are high for longer than 150us (idle condition).
4. I²C devices do not support the Alert Response Address functionality (which is optional for SMBus).
5. I²C devices support block read and write differently. I²C protocol allows for unlimited number of bytes to be sent in either direction. The SMBus protocol requires that an additional data byte indicating number of bytes to read / write is transmitted. The CAP1028 supports I²C formatting only.

3.3 SMBus Protocols

The CAP1028 is SMBus 2.0 compatible and supports Send Byte, Read Byte, Block Read, Receive Byte as valid protocols as shown below. The CAP1028 also supports the I²C block read and block write protocols. Finally, it will respond to the Alert Response Address protocol but is not in full compliance.

All of the below protocols use the convention in [Table 3.2](#).

Table 3.2 Protocol Format

DATA SENT TO DEVICE	DATA SENT TO THE HOST
Data sent	Data sent

3.3.1 SMBus Write Byte

The Write Byte is used to write one byte of data to a specific register as shown in [Table 3.3](#).

Table 3.3 Write Byte Protocol

START	SLAVE ADDRESS	WR	ACK	REGISTER ADDRESS	ACK	REGISTER DATA	ACK	STOP
1 -> 0	YYYY_YYY	0	0	XXh	0	XXh	0	0 -> 1

3.3.2 Block Write

The Block Write is used to write multiple data bytes to a group of contiguous registers as shown in [Table 3.4](#). It is an extension of the Write Byte Protocol.

APPLICATION NOTE: When using the Block Write protocol, the internal address pointer will be automatically incremented after every data byte is received. It will wrap from FFh to 00h.

Table 3.4 Block Write Protocol

START	SLAVE ADDRESS	WR	ACK	REGISTER ADDRESS	ACK	REGISTER DATA	ACK
1 -> 0	YYYY_YYY	0	0	XXh	0	XXh	0
REGISTER DATA	ACK	REGISTER DATA	ACK	...	REGISTER DATA	ACK	STOP
XXh	0	XXh	0	...	XXh	0	0 -> 1

3.3.3 SMBus Read Byte

The Read Byte protocol is used to read one byte of data from the registers as shown in [Table 3.5](#).

Table 3.5 Read Byte Protocol

START	SLAVE ADDRESS	WR	ACK	REGISTER ADDRESS	ACK	START	CLIENT ADDRESS	RD	ACK	REGISTER DATA	NACK	STOP
1->0	YYYY_YYY	0	0	XXh	0	1->0	YYYY_YYY	1	0	XXh	1	0 -> 1

3.3.4 Block Read

The Block Read is used to read multiple data bytes from a group of contiguous registers as shown in [Table 3.6](#). It is an extension of the Read Byte Protocol.

APPLICATION NOTE: When using the Block Read protocol, the internal address pointer will be automatically incremented after every data byte is received. It will wrap from FFh to 00h.

Table 3.6 Block Read Protocol

START	SLAVE ADDRESS	WR	ACK	REGISTER ADDRESS	ACK	START	SLAVE ADDRESS	RD	ACK	REGISTER DATA
1->0	YYYY_YYY	0	0	XXh	0	1->0	YYYY_YYY	1	0	XXh
ACK	REGISTER DATA	ACK	REGISTER DATA	ACK	REGISTER DATA	ACK	...	REGISTER DATA	NACK	STOP
0	XXh	0	XXh	0	XXh	0	...	XXh	1	0 -> 1

3.3.5 SMBus Send Byte

The Send Byte protocol is used to set the internal address register pointer to the correct address location. No data is transferred during the Send Byte protocol as shown in [Table 3.7](#).

Table 3.7 Send Byte Protocol

START	SLAVE ADDRESS	WR	ACK	REGISTER ADDRESS	ACK	STOP
1 -> 0	YYYY_YYY	0	0	XXh	0	0 -> 1

3.3.6 SMBus Receive Byte

The Receive Byte protocol is used to read data from a register when the internal register address pointer is known to be at the right location (e.g. set via Send Byte). This is used for consecutive reads of the same register as shown in [Table 3.8](#).

Table 3.8 Receive Byte Protocol

START	SLAVE ADDRESS	RD	ACK	REGISTER DATA	NACK	STOP
1 -> 0	YYYY_YYY	1	0	XXh	1	0 -> 1

3.4 SPI Interface

The SMBus has a predefined packet structure, the SPI does not. The SPI Bus can operate in two modes of operation, normal 4-wire mode and bi-directional 3-wire mode. All SPI commands consist of 8-bit packets set to a specific slave device (identified by the CS pin).

The SPI bus will latch data on the rising edge of the clock and the clock and data both idle high.

All commands are supported via both operating modes. The supported commands are: Reset Serial interface, set address pointer, write command and read command. Note that all other codes received during the command phase are ignored and have no effect on the operation of the device.

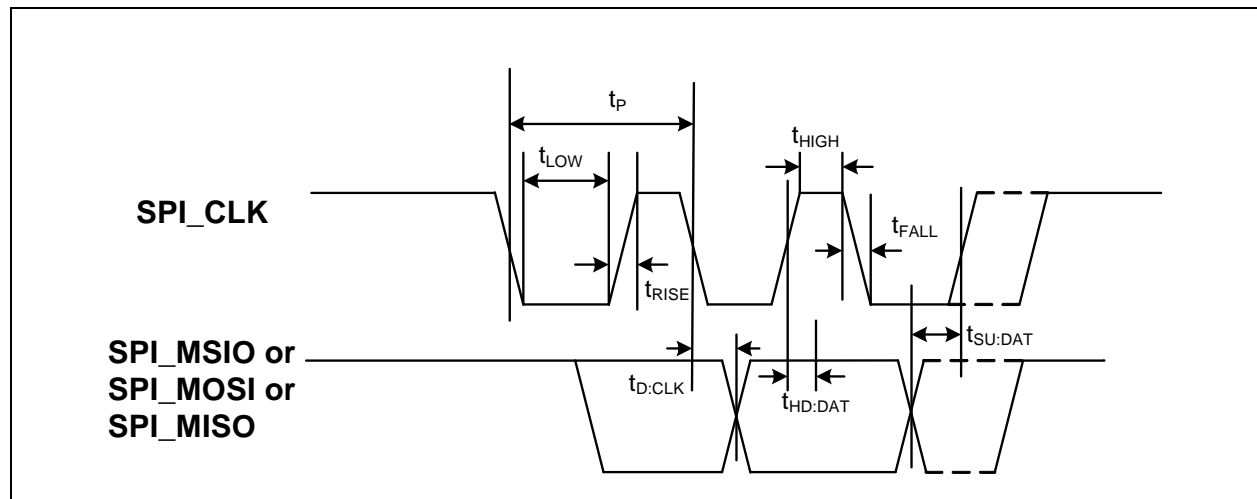

Figure 3.1 SPI Timing

3.4.1 SPI Normal Mode

The SPI Bus can operate in two modes of operation, normal and bi-directional mode. In the normal mode of operation, there are dedicated input and output data lines. The host communicates by sending a command along the CAP1028 SPI_MOSI data line and reading data on the SPI_MISO data line. Both communications occur simultaneously which allows for larger throughput of data transactions.

All basic transfers consist of two 8 bit transactions from the Master device while the slave device is simultaneously sending data at the current address pointer value.

Data writes consist of two or more 8-bit transactions. The host sends a specific write command followed by the data to write the address pointer. Data reads consist of one or more 8-bit transactions. The host sends the specific read data command and continues clocking for as many data bytes as it wishes to receive.

3.4.2 SPI Bi-Directional Mode

In the bi-directional mode of operation, the SPI data signals are combined into the SPI_MSIO line, which is shared for data received by the device and transmitted by the device. The protocol uses a simple handshake and turn around sequence for data communications based on the number of clocks transmitted during each phase.

All basic transfers consist of two 8 bit transactions. The first is an 8 bit command phase driven by the Master device. The second is by an 8 bit data phase driven by the Master for writes, and by the CAP1028 for read operations.

The auto increment feature of the address pointer allows for successive reads or writes. The address pointer will return to 00h after reaching FFh.

3.4.3 SPI_CS# Pin

The SPI Bus is a single master, multiple slave serial bus. Each slave has a dedicated CS pin (chip select) that the master asserts low to identify that the slave is being addressed. There are no formal addressing options.

3.4.4 Address Pointer

All data writes and reads are accessed from the current address pointer. In both Bi-directional mode and Full Duplex mode, the Address pointer is automatically incremented following every read command or every write command.

The address pointer will return to 00h after reaching FFh.

3.4.5 SPI Timeout

The CAP1028 does not detect any timeout conditions on the SPI bus.

3.5 Normal SPI Protocols

When operating in normal mode, the SPI bus internal address pointer is incremented depending upon which command has been transmitted. Multiple commands may be transmitted sequentially so long as the SPI_CS# pin is asserted low. [Figure 3.1](#) shows an example of this operation.

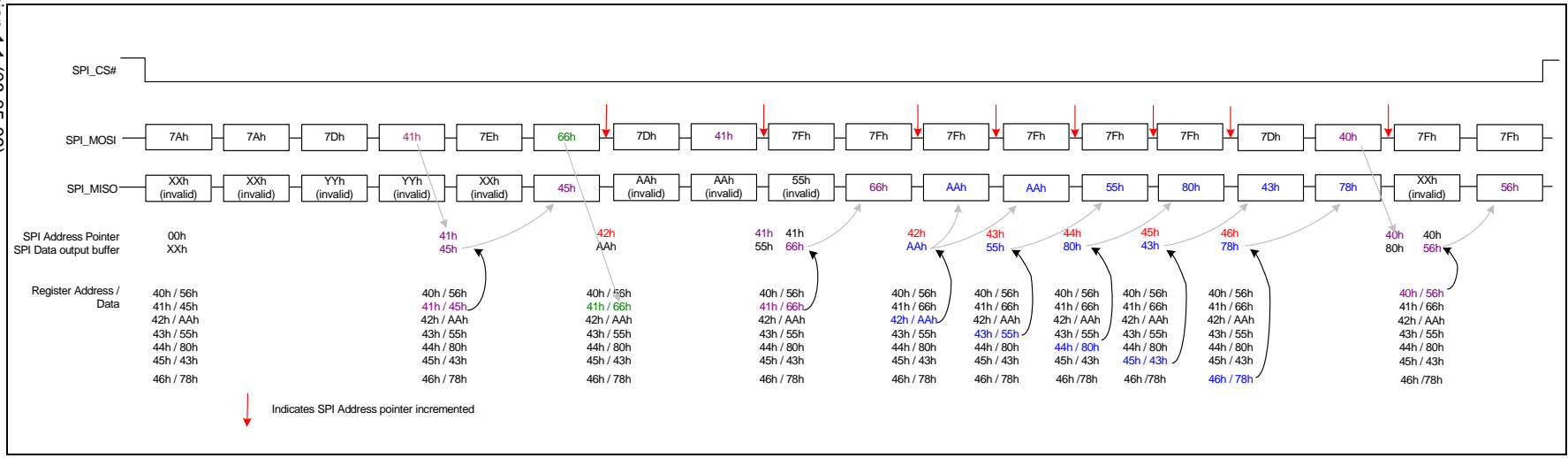
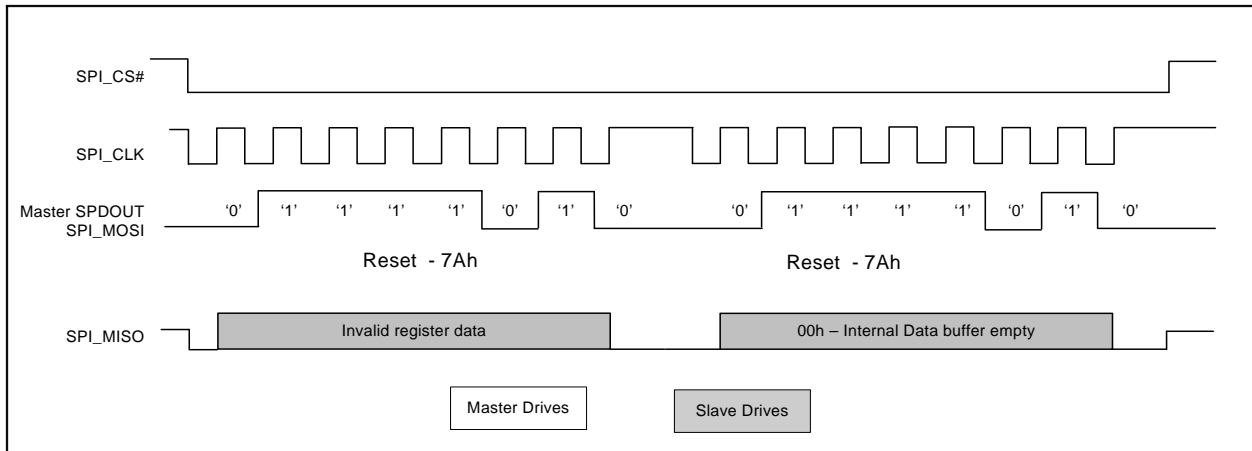

Figure 3.1 Example SPI Bus Communication - Normal Mode

3.5.1 Reset Interface

Resets the Serial interface whenever two successive 7Ah codes are received. Regardless of the current phase of the transaction - command or data, the receipt of the successive reset commands resets the Serial communication interface only. All other functions are not affected by the reset operation.

Figure 3.2 SPI Reset Interface Command - Normal Mode

3.5.2 Set Address Pointer

The Set Address Pointer command sets the Address pointer for subsequent reads and writes of data. The pointer is set on the rising edge of the final data bit. At the same time, the data that is to be read is fetched and loaded into the internal output buffer but is not transmitted.

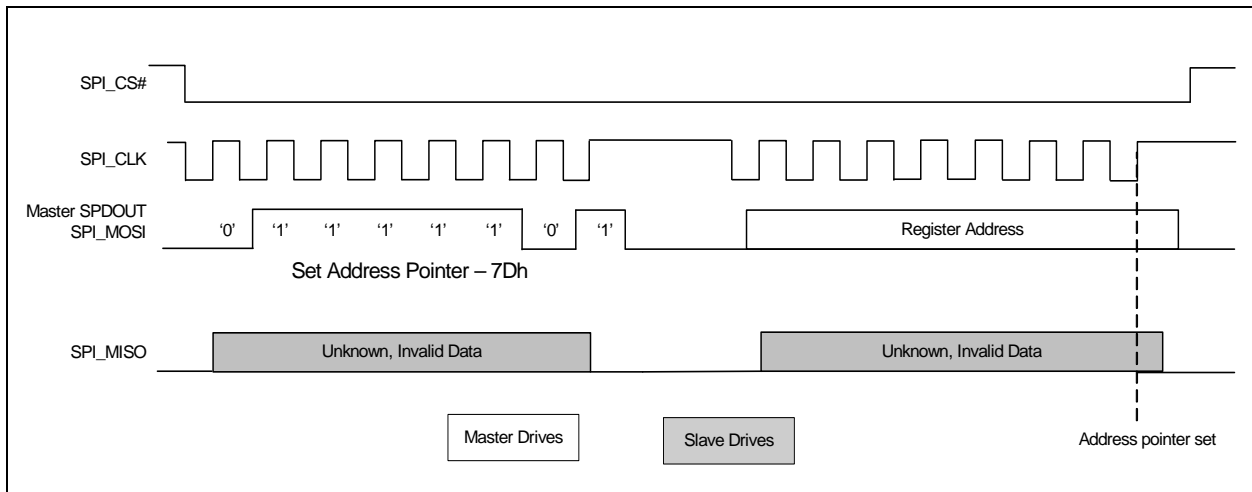
Figure 3.3 SPI Set Address Pointer Command - Normal Mode

3.5.3 Write Data

The Write Data protocol updates the contents of the register referenced by the address pointer. As the command is processed, the data to be read is fetched and loaded into the internal output buffer but not transmitted. Then, the register is updated with the data to be written. Finally, the address pointer is incremented.

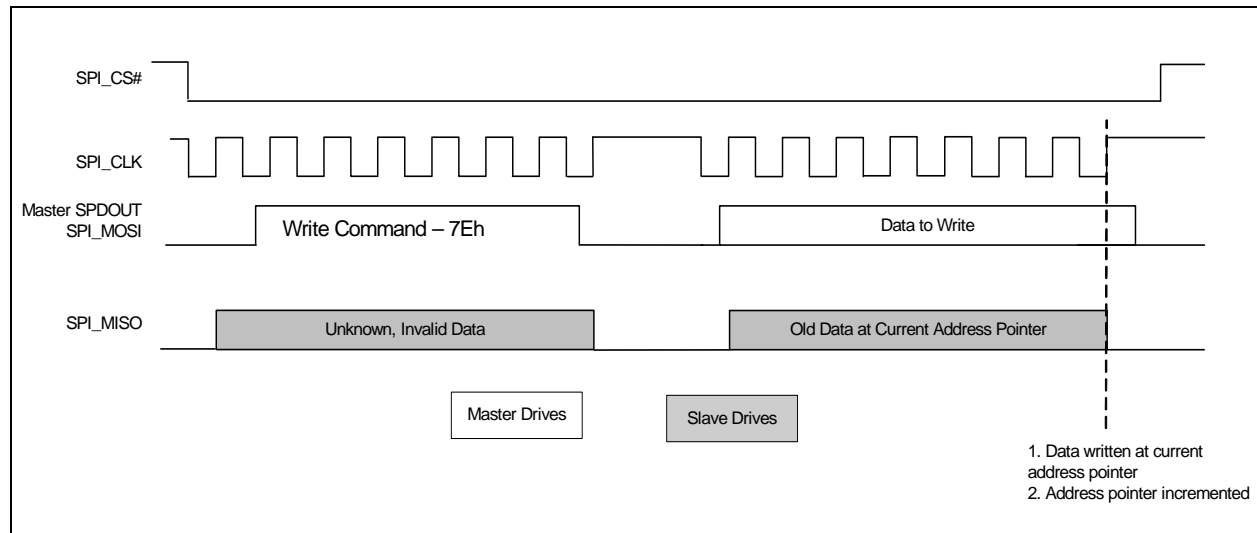

Figure 3.4 SPI Write Command - Normal Mode

3.5.4 Read Data

The Read Data protocol is used to read data from the device. During the normal mode of operation, while the device is receiving data, the CAP1028 is simultaneously transmitting data to the host. For the Set Address commands and the Write Data commands, this data may be invalid and it is recommended that the Read Data command is used.

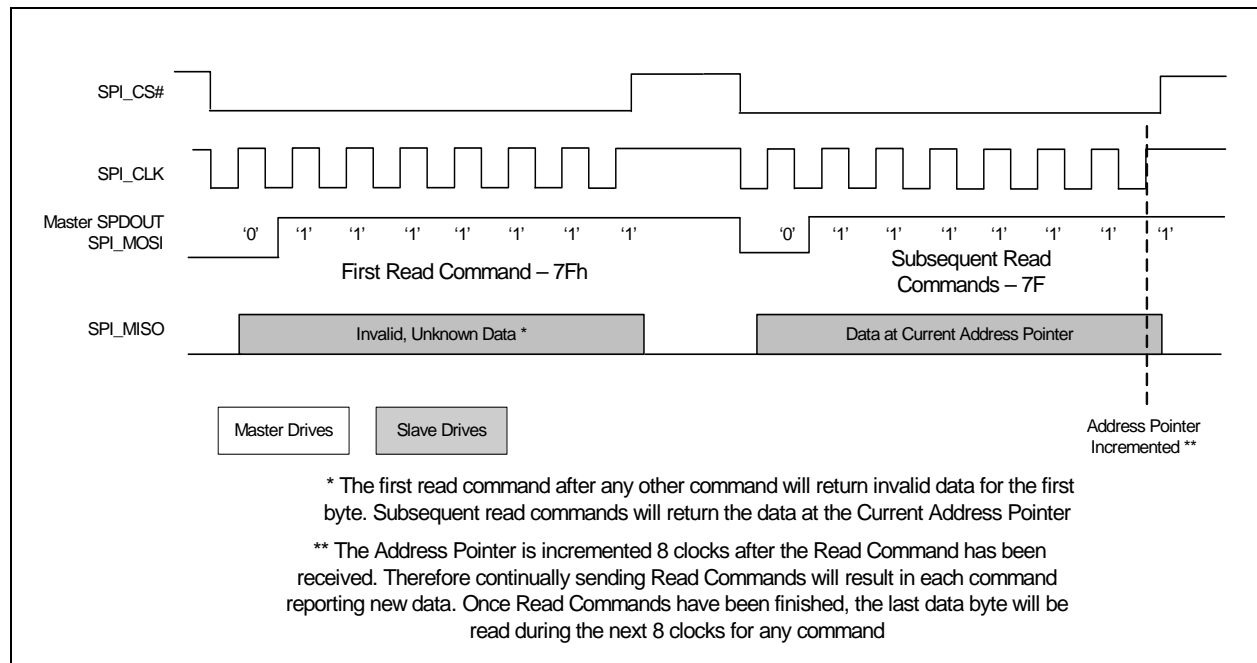
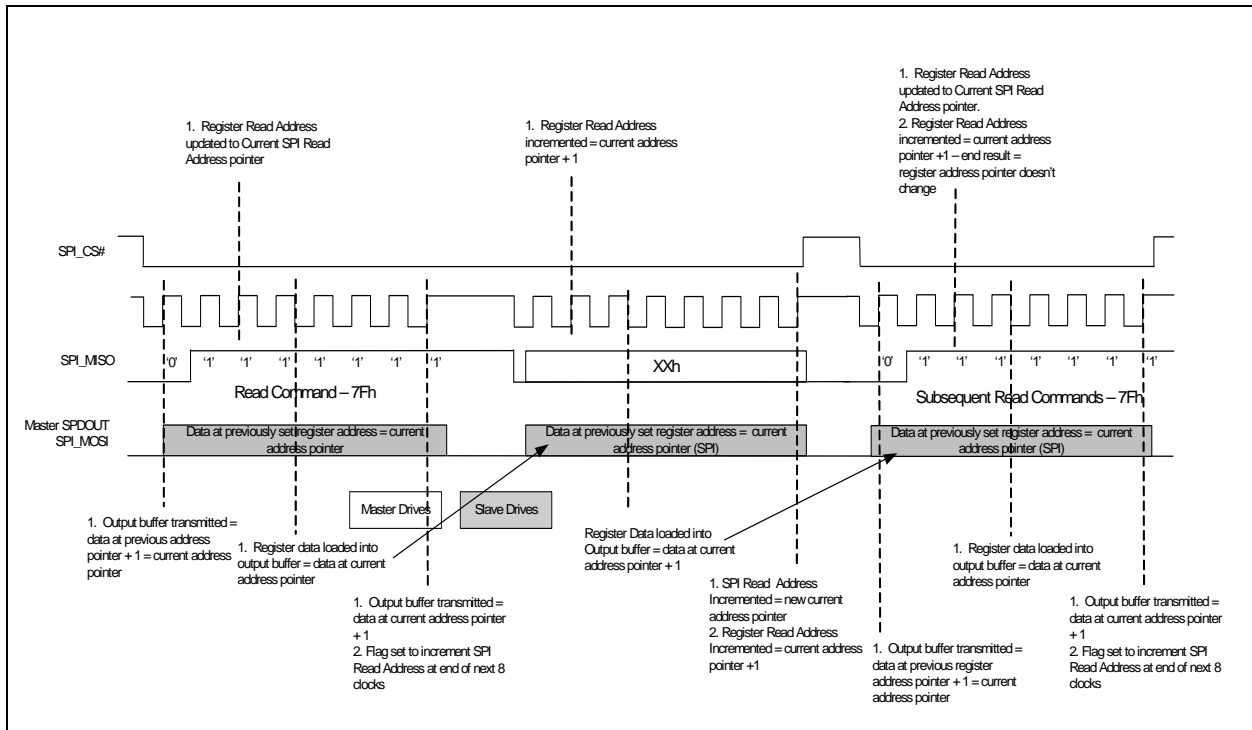

Figure 3.5 SPI Read Command - Normal Mode

Figure 3.6 SPI Read Command - Normal Mode - Full

3.6 Bi-Directional SPI Protocols

3.6.1 Reset Interface

Resets the Serial interface whenever two successive 7Ah codes are received. Regardless of the current phase of the transaction - command or data, the receipt of the successive reset commands resets the Serial communication interface only. All other functions are not affected by the reset operation.

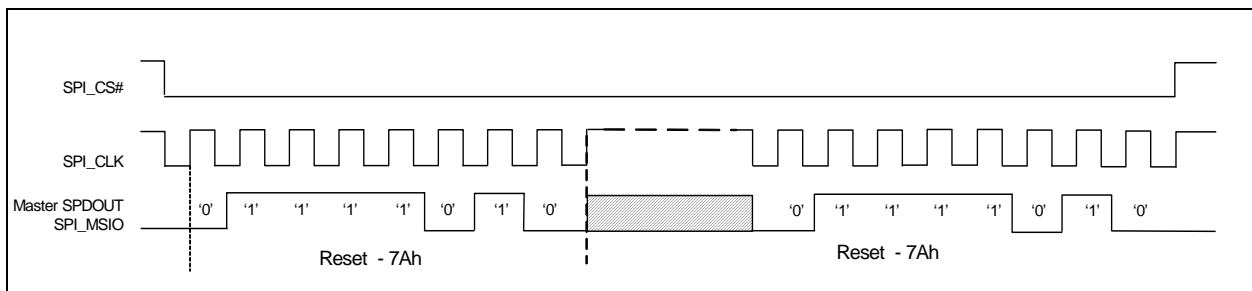
Figure 3.7 SPI Reset Interface Command - Bi-directional Mode

3.6.2 Set Address Pointer

Sets the address pointer to the register to be accessed by a read or write command. This command overrides the auto-incrementing of the address pointer.

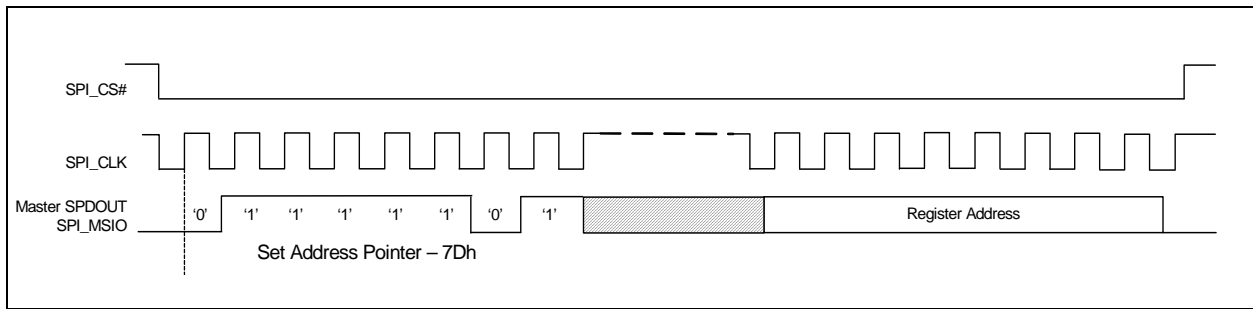

Figure 3.8 SPI Set Address Pointer Command - Bi-directional Mode

3.6.3 Write Data

Writes data value to the register address stored in the address pointer. Performs auto increment of address pointer after the data is loaded into the register.

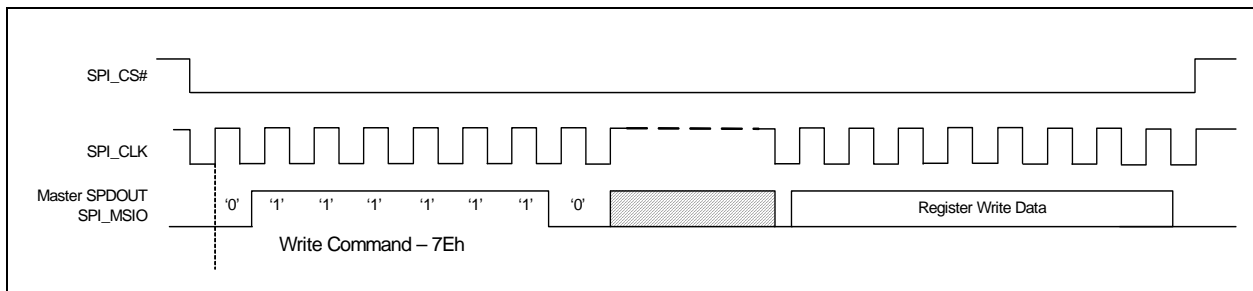

Figure 3.9 SPI Write Data Command - Bi-directional Mode

3.6.4 Read Data

Reads data referenced by the address pointer. Performs auto increment of address pointer after the data is transferred to the Master.

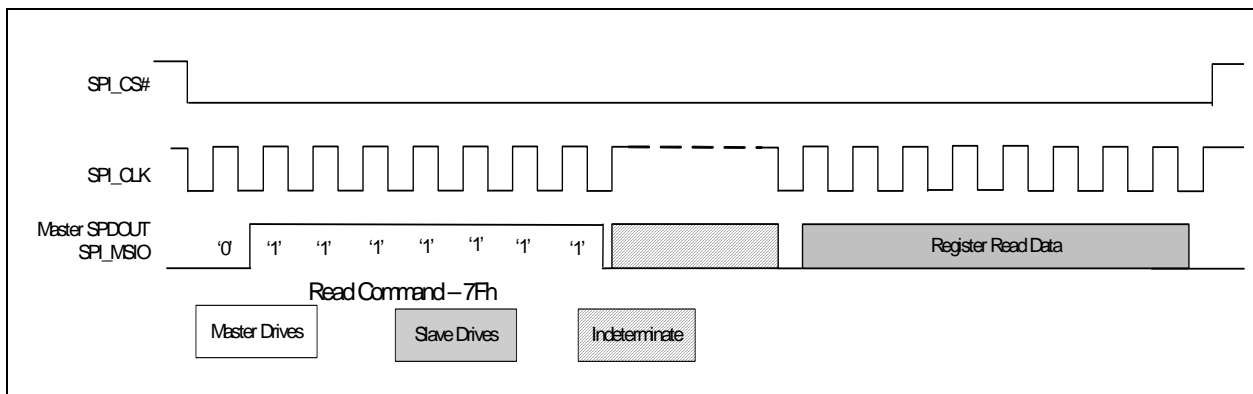

Figure 3.10 SPI Read Data Command - Bi-directional Mode

3.7 BC-Link Interface

The BC-Link is a proprietary bus developed to allow communication between a host controller device to a companion device. This device uses this serial bus to read and write registers and for interrupt

processing. The interface uses a data port concept, where the base interface has an address register, data register and a control register, defined in the SMSC's 8051's SFR space.

Refer to documentation for the BC-Link compatible host controller for details on how to access the CAP1028 via the BC-Link Interface.

Chapter 4 General Description

The CAP1028 is a multiple channel Capacitive Touch sensor with multiple power LED drivers. It contains eight (8) individual Capacitive Touch sensor inputs with programmable sensitivity for use in touch sensor applications. Each sensor automatically recalibrates to compensate for gradual environmental changes.

The CAP1028 also contains two (2) low side (or push-pull) LED drivers that offer full-on / off, variable rate blinking, dimness controls, and breathing. Each of the LED drivers may be linked to one of the sensors to be actuated when a touch is detected. As well, each LED driver may be individually controlled via a host controller.

Finally, the device contains a dedicated RESET pin to act as a soft reset by the system.

The CAP1028 offers multiple power states operating at low quiescent currents during its Deep Sleep state. The device also contains a wake pin (WAKE/SPI_MOSI) output to wake the system when a touch is detected in Standby and to wake the device from Deep Sleep. It can monitor one or more channels while in a lower power state and respond to communications normally.

The device communicates with a host controller using the SPI bus, SMSC BC-Link bus, or via SMBus / I²C. The host controller may poll the device for updated information at any time or it may configure the device to flag an interrupt whenever a touch is detected on any sensor.

A typical system diagram is shown in [Figure 4.1](#).

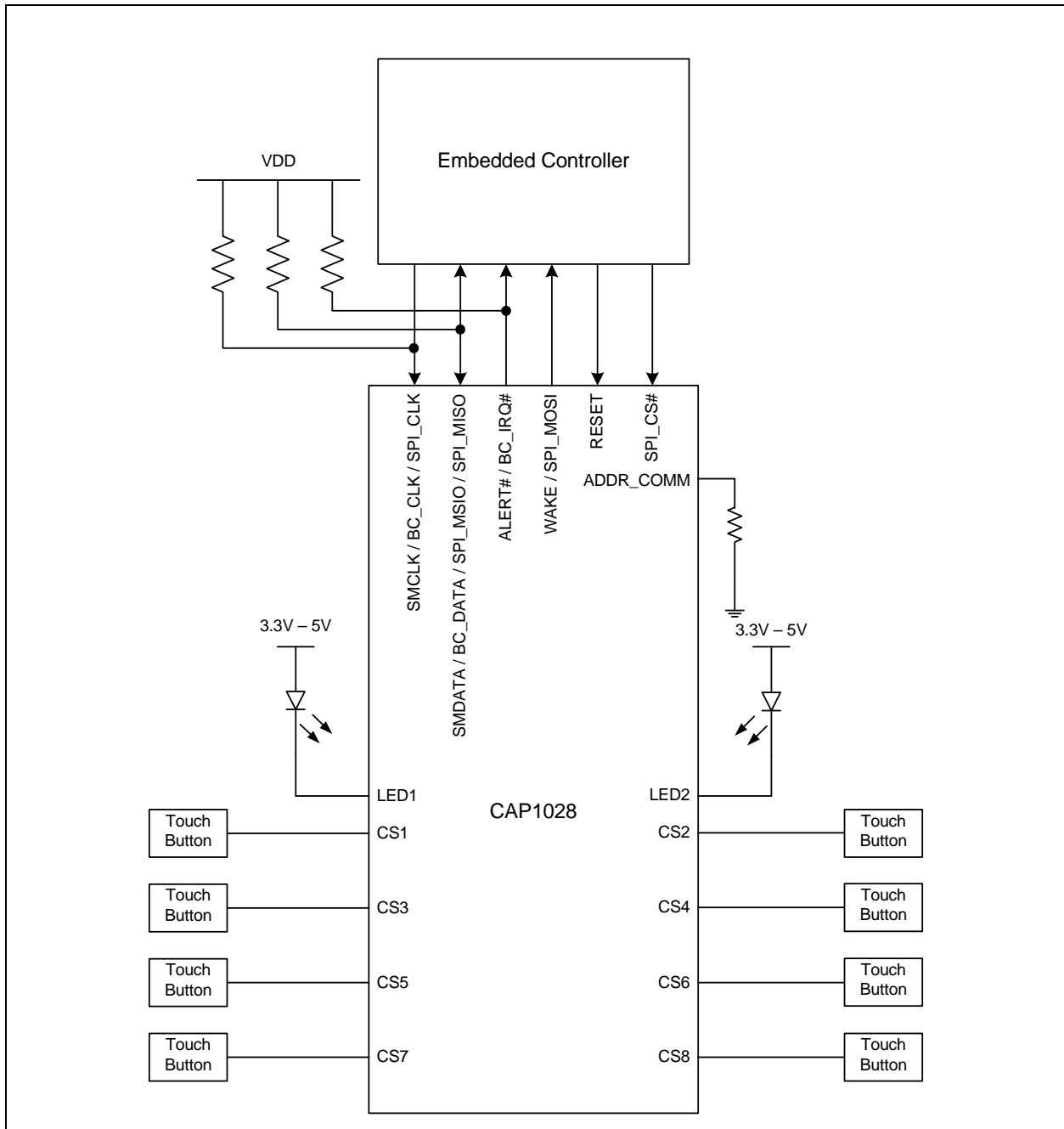

Figure 4.1 System Diagram for CAP1028

4.1 Power States

The CAP1028 has three operating states depending on the status of the STBY and DSLEEP bits. When the device transitions between power states, previously detected touches (for inactive channels) are cleared and the status bits reset.

Datasheet

1. Fully Active - The device is fully active. It is monitoring all active Capacitive Sensor channels and driving all LED channels as defined.
2. Standby - The device is in a lower power state. It will measure a programmable number of channels (as determined by the Standby Channel register - default none). Interrupts will still be generated based on the active channels. The device will still respond to communications normally and can be returned to the Fully Active state of operation by clearing the STBY bit.
3. Deep Sleep - The device is in its lowest power state. It is not monitoring any Capacitive Sensor channels. It can be awakened by SMBus or SPI communications targeting the device (which will cause the DSLEEP bit to be automatically cleared).

If the device is not communicating via the 4-wire SPI bus, then during this state of operation, if the WAKE/SPI_MOSI pin is driven high by an external source, the device will clear the DSLEEP bit and return to Fully Active.

APPLICATION NOTE: The Deep Sleep state does not change LED drive behavior so it is the user's responsibility to ensure that the LEDs are driven to the desired state prior to entering Deep Sleep. This is best achieved by unlinking the LEDs from the sensors and driving the LEDs to the desired state using the LED Output Control register.

APPLICATION NOTE: If the CAP1028 is configured to communicate using the BC-Link protocol, the device does not support Deep Sleep.

4.2 RESET Pin

The RESET pin is an active high reset that is driven from an external source. While it is asserted high, all the internal blocks will be held in reset including the communications protocol used. No Capacitive Touch sensors will be sampled and the LEDs will not be driven.

All configuration settings will be reset to default states (thus waking the device from Deep Sleep) and all readings will be cleared. Once the RESET pin is pulled low, the CAP1028 will begin operation as if a power-on-reset had occurred.

4.3 WAKE/SPI_MOSI Pin Operation

When the CAP1028 is placed in Standby, and is not communicating using the 4-wire SPI protocol, it will assert the WAKE/SPI_MOSI pin when a touch is detected on one of its sampled sensors. The pin will remain asserted until the INT bit has been cleared and then it will be de-asserted.

When the CAP1028 is placed in Deep Sleep and it is not communicating using the 4-wire SPI protocol, the WAKE/SPI_MOSI pin is monitored by the device as an input. If the WAKE/SPI_MOSI pin is driven high by an external source, the CAP1028 will clear the DSLEEP bit.

When the device is placed in Deep Sleep, this pin is a High-Z input and must have a pull-down resistor to GND for proper operation.

4.4 LED Drivers

The CAP1028 contains two (2) LED Drivers. Each LED driver can be configured to operate in one of the following modes with either push-pull or open drain drive. Additionally, each LED driver can be linked to the respective Capacitive Touch sensor input.

1. Direct - The LED is configured to be on or off when the corresponding input stimulus is on or off (or inverted). The brightness of the LED can be programmed from full off to full on (default). Additionally, the LED contains controls to individually configure ramping on, off, and turn-off delay.
2. Pulse 1 - The LED is configured to fade ON-OFF-ON a programmable number of times with programmable rate and min / max brightness. This behavior may be actuated when a press is detected, or when a release is detected.

3. Pulse 2 - The LED is configured to “Breathe” while actuated and then “Pulse” when the sensor is released.
4. Breathe - The LED is configured to fade continuously ON-OFF-ON (i.e. to “Breathe”) with a programmable rate and min / max brightness.

In addition to these four behaviors, all LED drivers support host initiated LED actuation. All LEDs also have an option to assert the ALERT# pin when the initiated behavior has reached its maximum or minimum brightness levels.

4.4.1 Linking LEDs to Capacitive Touch Sensors

All LEDs can be linked to the corresponding Capacitive Touch Sense input channel so that when the sensor detects a touch, the corresponding LED will be actuated at one of the programmed responses.

4.5 Capacitive Touch Sensing

The CAP1028 contains eight (8) independent Capacitive Touch Sensor inputs. Each sensor has dynamic range to detect a change of capacitance due to a touch. Additionally, each sensor can be configured to be automatically and routinely re-calibrated.

4.5.1 Sensing Cycle

Each Capacitive Touch Sensor has controls to be activated and included in the sensing cycle. When the device is active, it automatically initiates a sensing cycle and repeats the cycle every time it finishes. The cycle polls through each active Sensor starting with CS1 and extending through CS8. As each Capacitive Touch Sensor is polled, its measurement is compared against a baseline “not touched” measurement. If the delta measurement is large enough, then a touch is detected and an interrupt generated.

The sensing cycle time is programmable (see [Section 5.10](#)).

4.5.2 Recalibrating Sensors

Each sensor is regularly recalibrated at an adjustable rate. By default, the recalibration routine stores the average 256 previous measurements and periodically updates the base “Not Touched” setting for the Capacitive Touch Sensor input.

It is possible that the device loses sensitivity to a touch. This may happen as a result of a noisy environment, an accidental recalibration during a touch, or other environmental changes. When this occurs, then the base untouched sensor may generate negative delta count values. The device will detect this condition based on a programmable number of consecutive negative delta readings. When it detects the condition, the CAP1028 will automatically re-calibrate the base-count settings. During this recalibration, the device will not respond to touches.

4.6 ALERT# Pin

The ALERT# pin is an active low output that is driven when an interrupt event is detected.

Whenever an interrupt is generated, the INT bit (see [Section 5.1](#)) is set. The ALERT# pin is cleared when INT bit is cleared by the user. Additionally, when the INT bit is cleared by the user, status bits are only cleared if no touch is detected.

4.6.1 Sensor Interrupt Behavior

The sensor interrupts are generated in one of two ways:

1. An interrupt is generated when a touch is detected and when a release is detected (see [Figure 4.3](#)).

Datasheet

2. If the repeat rate is enabled (see [Section 5.6](#)), then, so long as the touch is held, another interrupt will be generated based on the programmed repeat rate (see [Figure 4.2](#)).

When the repeat rate is enabled, the device uses an additional control called MPRESS that determines whether a touch is flagged as a simple “touch” or a “press and hold”. The MPRESS[3:0] bits set a minimum press timer. When the button is touched the timer begins. If the sensor is released before the minimum press timer expires, then it is flagged as a touch and an interrupt is generated upon the release. If the sensor detects a touch for longer than this timer value, then it is flagged as a “press and hold” event. So long as the touch is held, interrupts will be generated at the programmed repeat rate and upon a release.

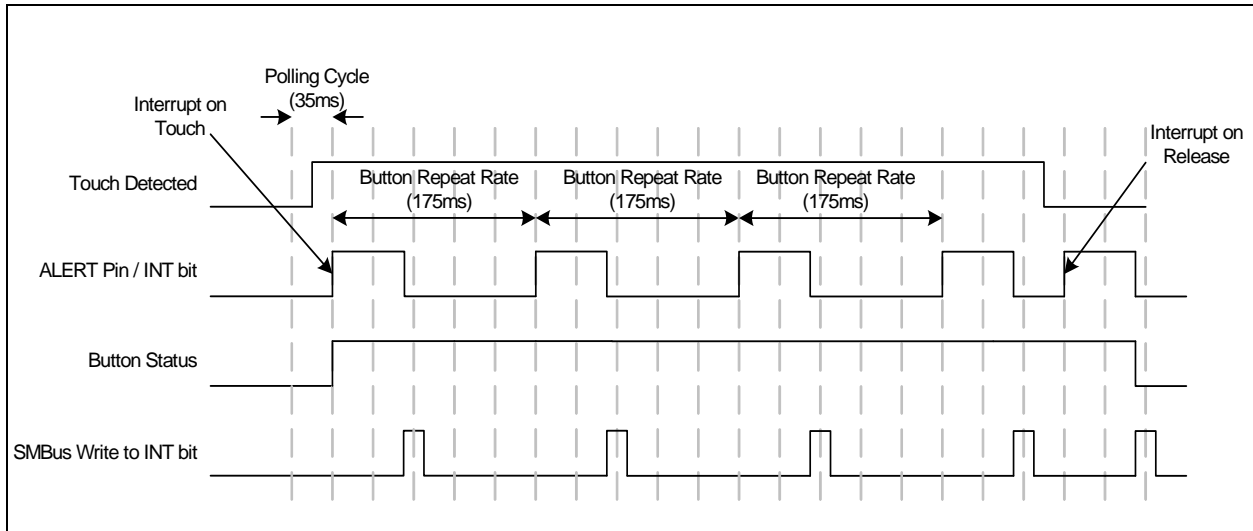

Figure 4.2 Sensor Interrupt Behavior - Repeat Rate Enabled

APPLICATION NOTE: The host may need to poll the device twice to determine that a release has been detected.

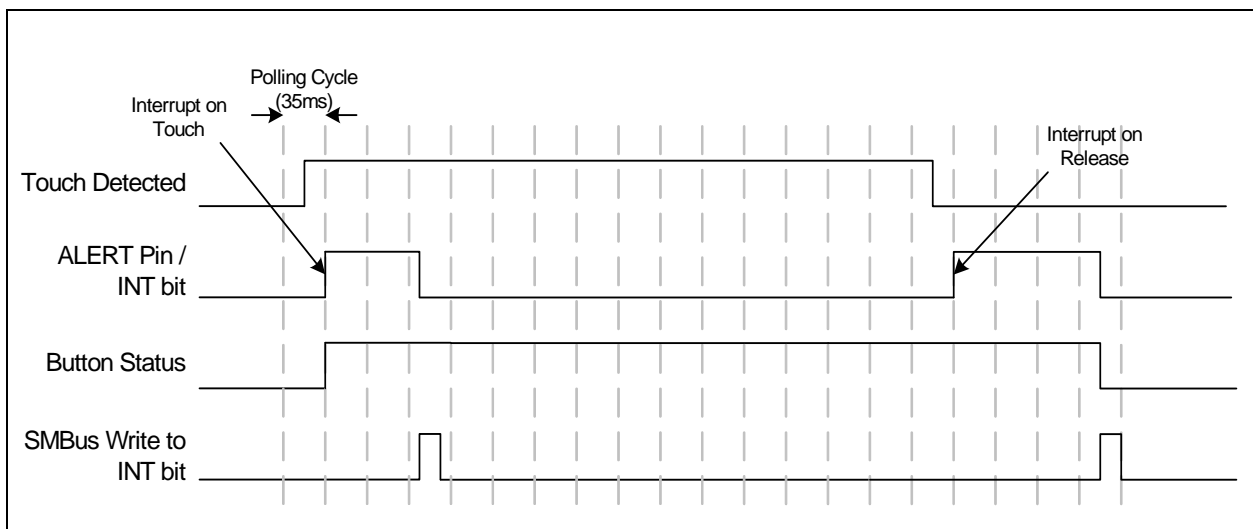

Figure 4.3 Sensor Interrupt Behavior - No Repeat Rate Enabled

Chapter 5 Register Description

The registers shown in [Table 5.1](#) are accessible through the communications protocol. An entry of ‘-’ indicates that the bit is not used and will always read ‘0’.

Table 5.1 Register Set in Hexadecimal Order

REGISTER ADDRESS	R/W	REGISTER NAME	FUNCTION	DEFAULT VALUE	PAGE
00h	R/W	Main Status Control	Controls general power states and power dissipation	00h	Page 35
03h	R	Sensor Status	Returns the state of the sampled Capacitive Touch Sensor	00h	Page 36
04h	R	LED Status	Stores status bits for LEDs	00h	Page 36
0Ah	R	Noise Flag Status	Stores the noise flags for sensors	00h	Page 37
10h	R	Sensor 1 Delta Count	Stores the delta count for CS1	00h	Page 37
11h	R	Sensor 2 Delta Count	Stores the delta count for CS2	00h	Page 37
12h	R	Sensor 3 Delta Count	Stores the delta count for CS3	00h	Page 37
13h	R	Sensor 4 Delta Count	Stores the delta count for CS4	00h	Page 37
14h	R	Sensor 5 Delta Count	Stores the delta count for CS5	00h	Page 37
15h	R	Sensor 6 Delta Count	Stores the delta count for CS6	00h	Page 37
16h	R	Sensor 7 Delta Count	Stores the delta count for CS7	00h	Page 37
17h	R	Sensor 8 Delta Count	Stores the delta count for CS8	00h	Page 37
1Fh	R/W	Sensitivity Control	Controls the sensitivity of the threshold and delta counts and data scaling of the base counts	2Fh	Page 38
20h	R/W	Configuration	Controls general functionality and LED controls	20h	Page 39
21h	R/W	Sensor Enable	Controls whether the Capacitive Touch Sensor inputs are sampled	FFh	Page 40
22h	R/W	Sensor Configuration	Controls reset delay and auto-repeat delay for sensors operating in the full power state	A4h	Page 40
23h	R/W	Sensor Configuration 2	Controls the MPRESS controls for all sensors	07h	Page 42
24h	R/W	Averaging and Sampling Config	Controls averaging and sampling window	1Dh	Page 42
26h	R/W	Calibration Activate	Activates manual re-calibration for Capacitive Touch Sensors	FFh	Page 44
27h	R/W	Interrupt Enable	Enables Interrupts associated with Capacitive Touch Sensors	FFh	Page 44

Table 5.1 Register Set in Hexadecimal Order (continued)

REGISTER ADDRESS	R/W	REGISTER NAME	FUNCTION	DEFAULT VALUE	PAGE
28h	R/W	Repeat Rate Enable	Enables repeat rate for Capacitive Touch Sensors	FFh	Page 45
2Ah	R/W	Multiple Press Configuration	Determines the number of simultaneous touches to flag a multiple touch condition	80h	Page 46
2Fh	R/W	Recalibration Configuration	Determines re-calibration timing and sampling window	8Bh	Page 46
30h	R/W	Sensor 1 Threshold	Stores the delta count threshold to determine a touch for Capacitive Touch Sensor 1	40h	Page 48
31h	R/W	Sensor 2 Threshold	Stores the delta count threshold to determine a touch for Capacitive Touch Sensor 2	40h	Page 48
32h	R/W	Sensor 3 Threshold	Stores the delta count threshold to determine a touch for Capacitive Touch Sensor 3	40h	Page 48
33h	R/W	Sensor 4 Threshold	Stores the delta count threshold to determine a touch for Capacitive Touch Sensor 4	40h	Page 48
34h	R/W	Sensor 5 Threshold	Stores the delta count threshold to determine a touch for Capacitive Touch Sensor 5	40h	Page 48
35h	R/W	Sensor 6 Threshold	Stores the delta count threshold to determine a touch for Capacitive Touch Sensor 6	40h	Page 48
36h	R/W	Sensor 7 Threshold	Stores the delta count threshold to determine a touch for Capacitive Touch Sensor 7	40h	Page 48
37h	R/W	Sensor 8 Threshold	Stores the delta count threshold to determine a touch for Capacitive Touch Sensor 8	40h	Page 48
38h	R/W	Sensor Noise Threshold 1	Stores controls for selecting the noise threshold for sensors 1 - 4	55h	Page 48
39h	R/W	Sensor Noise Threshold 2	Stores controls for selecting the noise threshold for sensors 5 - 8	55h	Page 48
Standby Configuration Registers					
40h	R/W	Standby Channel	Controls which sensors are enabled while in standby	00h	Page 49
41h	R/W	Standby Configuration	Controls averaging and cycle time while in standby	1Dh	Page 50
42h	R/W	Standby Sensitivity	Controls sensitivity settings used while in standby	02h	Page 51
43h	R/W	Standby Threshold	Stores the touch detection threshold for active sensors in standby	40h	Page 52

Table 5.1 Register Set in Hexadecimal Order (continued)

REGISTER ADDRESS	R/W	REGISTER NAME	FUNCTION	DEFAULT VALUE	PAGE
50h	R	Sensor 1 Base Count	Stores the reference count value for sensor 1	C8h	Page 52
51h	R	Sensor 2 Base Count	Stores the reference count value for sensor 2	C8h	Page 52
52h	R	Sensor 3 Base Count	Stores the reference count value for sensor 3	C8h	Page 52
53h	R	Sensor 4 Base Count	Stores the reference count value for sensor 4	C8h	Page 52
54h	R	Sensor 5 Base Count	Stores the reference count value for sensor 5	C8h	Page 52
55h	R	Sensor 6 Base Count	Stores the reference count value for sensor 6	C8h	Page 52
56h	R	Sensor 7 Base Count	Stores the reference count value for sensor 7	C8h	Page 52
57h	R	Sensor 8 Base Count	Stores the reference count value for sensor 8	C8h	Page 52
71h	R/W	LED Output Type	Controls the output type for the LED outputs	00h	Page 53
72h	R/W	Sensor LED Linking	Controls linking of sensors to LED channels	00h	Page 55
73h	R/W	LED Polarity	Controls the output polarity of LEDs	00h	Page 56
74h	R/W	LED Output Control	Controls the output state of the LEDs	00h	Page 53
81h	R/W	LED Behavior 1	Controls the behavior and response of LEDs 1 - 2	00h	Page 56
84h	R/W	LED Pulse 1 Period	Controls the period of each breathe during a pulse	20h	Page 57
85h	R/W	LED Pulse 2 Period	Controls the period of the breathing during breathe and pulse operation	14h	Page 59
86h	R/W	LED Breathe Period	Controls the period of an LED breathe operation	5Dh	Page 60
88h	R/W	LED Config	Controls LED configuration	04h	Page 61
90h	R/W	LED Pulse 1 Duty Cycle	Determines the min and max duty cycle for the pulse operation	F0h	Page 62
91h	R/W	LED Pulse 2 Duty Cycle	Determines the min and max duty cycle for breathe and pulse operation	F0h	Page 62
92h	R/W	LED Breathe Duty Cycle	Determines the min and max duty cycle for the breathe operation	F0h	Page 62
93h	R/W	LED Direct Duty Cycle	Determines the min and max duty cycle for Direct mode LED operation	F0h	Page 62

Table 5.1 Register Set in Hexadecimal Order (continued)

REGISTER ADDRESS	R/W	REGISTER NAME	FUNCTION	DEFAULT VALUE	PAGE
94h	R/W	LED Direct Ramp Rates	Determines the rising and falling edge ramp rates of the LEDs	00h	Page 63
95h	R/W	LED Off Delay	Determines the off delay for all LED behaviors	00h	Page 64
FDh	R	Product ID	Stores a fixed value that identifies each product	42h	Page 65
FEh	R	Manufacturer ID	Stores a fixed value that identifies SMSC	5Dh	Page 65
FFh	R	Revision	Stores a fixed value that represents the revision number	81h	Page 65

During Power-On-Reset (POR), the default values are stored in the registers. A POR is initiated when power is first applied to the part and the voltage on the VDD supply surpasses the POR level as specified in the electrical characteristics. Any reads to undefined registers will return 00h. Writes to undefined registers will not have an effect.

5.1 Main Status Control Register

Table 5.2 Main Status Control Register

ADDR	R/W	REGISTER	B7	B6	B5	B4	B3	B2	B1	B0	DEFAULT
00h	R/W	Main Status Control	-	-	STBY	DSLEEP	-	-	-	INT	00h

The Main Status and Control register controls the primary power state of the device.

Bit 5 - STBY - Enables Standby.

- '0' (default) - Sensor scanning is active and LEDs are functional.
- '1' - Capacitive Touch Sensor scanning is limited to the sensors set in the Standby Channel register (see [Section 5.18](#)). The status registers will not be cleared until read. LEDs that are linked to Capacitive Touch sensors will remain linked and active. Sensors that are no longer sampled will flag a release and then remain in a non-touched state. LEDs that are manually controlled will be unaffected.

Bit 4 - DSLEEP - Enables Deep Sleep by deactivating all functions. This bit will be cleared when the WAKE pin is driven high or when SPI or SMBus are received targeting the CAP1028. If the CAP1028 is configured to communicate using the BC-Link protocol, then this bit is ignored.

- '0' (default) - Sensor scanning is active and LEDs are functional.
- '1' - All sensor scanning is disabled and all LEDs are disabled. The status registers are automatically cleared and the INT bit is cleared.

Bit 0 - INT - Indicates that there is an interrupt. This bit is only set if the ALERT# pin has been asserted. If a channel detects a touch and its associated interrupt enable bit is not set to a logic '1' then no action is taken.

This bit is cleared by writing a logic '0' to it. When this bit is cleared, the ALERT# pin will be deasserted and all status registers will be cleared if the condition has been removed. If the WAKE/SPI_MOSI pin

is asserted as a result of a touch detected while in Standby, it will likewise be deasserted when this bit is cleared.

Note that this pin is not driven when communicating via the 4-wire SPI protocol

- '0' - No interrupt pending.
- '1' - A touch has been detected on one or more channels and the interrupt has been asserted.

5.2 Status Registers

Table 5.3 Status Registers

ADDR	R/W	REGISTER	B7	B6	B5	B4	B3	B2	B1	B0	DEFAULT
03h	R	Sensor Status	CS8	CS7	CS6	CS5	CS4	CS3	CS2	CS1	00h
04h	R	LED Status	-	-	-	-	-	-	LED2_ DN	LED1_ DN	00h

The Sensor Status Registers store status bits that indicate a touch has been detected. A value of '0' in any bit indicates that no touch has been detected. A value of '1' in any bit indicates that a touch has been detected.

All status bits are cleared when the device enters the Deep Sleep (DSLEEP = '1' - see [Section 5.1](#)). All status bits are cleared when the INT bit is cleared and if a touch on the respective Capacitive Touch Sensor is no longer present. If a touch is still detected, then the bits will not be cleared (but this will not cause the interrupt to be asserted - see [Section 5.6](#)).

5.2.1 Sensor Status

Bit 7 - CS8 - Indicates that a touch was detected on Sensor 8.

Bit 6 - CS7 - Indicates that a touch was detected on Sensor 7.

Bit 5 - CS6 - Indicates that a touch was detected on Sensor 6.

Bit 4 - CS5 - Indicates that a touch was detected on Sensor 5.

Bit 3 - CS4 - Indicates that a touch was detected on Sensor 4.

Bit 2 - CS3 - Indicates that a touch was detected on Sensor 3.

Bit 1 - CS2 - Indicates that a touch was detected on Sensor 2. This sensor can be linked to LED2.

Bit 0 - CS1 - Indicates that a touch was detected on Sensor 1. This sensor can be linked to LED1.

5.2.2 LED Status

Bit 1 - LED2_DN - Indicates that LED2 has finished its ramping behavior as determined by the LED2_CTL bits.

Bit 0 - LED1_DN - Indicates that LED1 has finished its ramping behavior as determined by the LED1_CTL bits.

5.3 Noise Flag Status Registers

Table 5.4 Noise Flag Status Registers

ADDR	R/W	REGISTER	B7	B6	B5	B4	B3	B2	B1	B0	DEFAULT
0Ah	R	Noise Flag Status	CS8_NOISE	CS7_NOISE	CS6_NOISE	CS5_NOISE	CS4_NOISE	CS3_NOISE	CS2_NOISE	CS1_NOISE	00h

The Noise Flag Status registers store status bits that are generated from the analog block if the detected noise is above the operating region of the analog detector. These bits indicate that the most recently received data from the sensor is invalid and should not be used for touch detection. Furthermore, so long as the bit is set for a particular channel, no decisions are made with the data. A touch is not detected, and a release is not detected.

These bits are not sticky and will be cleared automatically if the analog block does not report a noise error.

5.4 Sensor Delta Count Registers

Table 5.5 Sensor Delta Count Registers

ADDR	R/W	REGISTER	B7	B6	B5	B4	B3	B2	B1	B0	DEFAULT
10h	R	Sensor 1 Delta Count	Sign	64	32	16	8	4	2	1	00h
11h	R	Sensor 2 Delta Count	Sign	64	32	16	8	4	2	1	00h
12h	R	Sensor 3 Delta Count	Sign	64	32	16	8	4	2	1	00h
13h	R	Sensor 4 Delta Count	Sign	64	32	16	8	4	2	1	00h
14h	R	Sensor 5 Delta Count	Sign	64	32	16	8	4	2	1	00h
15h	R	Sensor 6 Delta Count	Sign	64	32	16	8	4	2	1	00h
16h	R	Sensor 7 Delta Count	Sign	64	32	16	8	4	2	1	00h
17h	R	Sensor 8 Delta Count	Sign	64	32	16	8	4	2	1	00h

The Sensor Delta Count registers store the delta count that is compared against the threshold used to determine if a touch has been detected. The count value represents a change in input due to the capacitor associated with a touch on one of the sensors and is referenced to a calibrated base “Not touched” count value. The delta is an instantaneous change and is updated once per sensor per sensing cycle (see [Section 4.5.1](#) - sensor cycle).

The value presented is a standard 2's complement number. In addition, the value is capped at a value of 7Fh. A reading of 7Fh indicates that the sensitivity settings are too high and should be adjusted accordingly (see [Section 5.5](#)).

The value is also capped at a negative value of FFh for negative delta counts which may result upon a release.

5.5 Sensitivity Control Register

Table 5.6 Sensitivity Control Register

ADDR	R/W	REGISTER	B7	B6	B5	B4	B3	B2	B1	B0	DEFAULT
1Fh	R/W	Sensitivity Control	-	DELTA_SENSE[2:0]			BASE_SHIFT[3:0]				2Fh

The Sensitivity Control register controls the sensitivity of a touch detection.

Bits 6- 4 DELTA_SENSE[2:0] - Controls the sensitivity of a touch detection. The sensitivity settings act to scale the relative delta count value higher or lower based on the system parameters. A setting of 000b is the most sensitive while a setting of 111b is the least sensitive. At the more sensitive settings, touches are detected for a smaller delta C corresponding to a “lighter” touch. These settings are more sensitive to noise however and a noisy environment may flag more false touches than higher sensitivity levels.

APPLICATION NOTE: A value of 128x is the most sensitive setting available. At the most sensitivity settings, the MSB of the Delta Count register represents 64 out of ~25,000 which corresponds to a touch of approximately 0.25% of the base capacitance (or a ΔC of 25fF from a 10pF base capacitance). Conversely a value of 1x is the least sensitive setting available. At these settings, the MSB of the Delta Count register corresponds to a delta count of 8192 counts out of ~25,000 which corresponds to a touch of approximately 33% of the base capacitance (or a ΔC of 3.33pF from a 10pF base capacitance).

Table 5.7 DELTA_SENSE Bit Decode

DELTA_SENSE[2:0]			SENSITIVITY MULTIPLIER
2	1	0	
0	0	0	128x (most sensitive)
0	0	1	64x
0	1	0	32x (default)
0	1	1	16x
1	0	0	8x
1	0	1	4x
1	1	0	2x
1	1	1	1x - (least sensitive)

Bits 3 - 0 - BASE_SHIFT[3:0] - Controls the scaling and data presentation of the Base Count registers. The higher the value of these bits, the larger the range and the lower the resolution of the data presented. The scale factor represents the multiplier to the bit-weighting presented in these register descriptions.

APPLICATION NOTE: The BASE_SHIFT[3:0] bits normally do not need to be updated. These settings will not affect touch detection or sensitivity. These bits are sometimes helpful in analyzing the Cap Sensing board performance and stability.

Table 5.8 BASE_SHIFT Bit Decode

BASE_SHIFT[3:0]				DATA SCALING FACTOR
3	2	1	0	
0	0	0	0	1x
0	0	0	1	2x
0	0	1	0	4x
0	0	1	1	8x
0	1	0	0	16x
0	1	0	1	32x
0	1	1	0	64x
0	1	1	1	128x
1	0	0	0	256x
All others				256x (default = 1111b)

5.6 Configuration Register

Table 5.9 Configuration Register

ADDR	R/W	REGISTER	B7	B6	B5	B4	B3	B2	B1	B0	DEFAULT
20h	R/W	Configuration	TIMEOUT	WAKE_CFG	BLK_DIG_NOISE	BLK_ANA_NOISE	MAX_DUR_EN	-	-	-	20h

The Configuration register controls general global functionality that affects the entire device.

Bit 7 - TIMEOUT - Enables the timeout and idle functionality of the SMBus protocol.

- '0' (default) - The SMBus timeout and idle functionality are disabled. The SMBus interface will not time out if the clock line is held low. Likewise, it will not reset if both the data and clock lines are held high for longer than 150us. This is used for I²C compliance.
- '1' - The SMBus timeout and idle functionality are enabled. The SMBus interface will time out if the clock line is held low for longer than 30ms. Likewise, it will reset if both the data and clock lines are held high for longer than 150us.

Bit 6 - WAKE_CFG - Configures the operation of the WAKE pin.

- '0' (default) - The WAKE pin is not asserted when a touch is detected while the device is in Standby. It will still be used to wake the device from Deep Sleep when driven high.
- '1' - The WAKE pin will be asserted high when a touch is detected while the device is in Standby. It will also be used to wake the device from Deep Sleep when driven high.

Bit 5 - BLK_DIG_NOISE - Determines whether the digital noise threshold is used by the device.

- '0' - The digital noise threshold is used. If a delta count value exceeds the noise threshold but does not exceed the touch threshold, then the sample is discarded and not used for the automatic re-calibration routine.

- '1' (default) - The noise threshold is not used. Any delta count that is less than the touch threshold is used for the automatic re-calibration routine.

Bit 4 - BLK_ANA_NOISE - Determines whether the analog noise flag setting will block a touch detection as well as the analog calibration routine.

- '0' (default) - If the analog noise bit is set, then a touch is blocked on the corresponding channel and will force the analog calibration routine to retry.
- '1' - A touch is not blocked even if the analog noise bit is set. Likewise, the analog calibration routine will not retry if the analog noise bit is set.

Bit 3 - MAX_DUR_EN - Determines whether the maximum duration recalibration is enabled for non-grouped sensors.

- '0' (default) - The maximum duration recalibration functionality is disabled. A touch may be held indefinitely and no re-calibration will be performed on any sensor.
- '1' - The maximum duration recalibration functionality is enabled. If a touch is held for longer than the MAX_DUR bit settings, then the re-calibration routine will be restarted (see [Section 5.8](#)).

5.7 Sensor Enable Registers

Table 5.10 Sensor Enable Registers

ADDR	R/W	REGISTER	B7	B6	B5	B4	B3	B2	B1	B0	DEFAULT
21h	R/W	Sensor Enable	CS8_EN	CS7_EN	CS6_EN	CS5_EN	CS4_EN	CS3_EN	CS2_EN	CS1_EN	FFh

The Sensor Enable registers determine whether a Capacitive Touch Sensor input is included in the sampling cycle. The length of the sampling cycle is not affected by the number of sensors measured.

Bit 7 - CS8_EN - Enables the CS8 input to be included during the sampling cycle.

- '0' - The CS8 input is not included in the sampling cycle.
- '1' (default) - The CS8 input is included in the sampling cycle.

Bit 6 - CS7_EN - Enables the CS7 input to be included during the sampling cycle.

Bit 5 - CS6_EN - Enables the CS6 input to be included during the sampling cycle.

Bit 4 - CS5_EN - Enables the CS5 input to be included during the sampling cycle.

Bit 3 - CS4_EN - Enables the CS4 input to be included during the sampling cycle.

Bit 2 - CS3_EN - Enables the CS3 input to be included during the sampling cycle.

Bit 1 - CS2_EN - Enables the CS2 input to be included during the sampling cycle.

Bit 0 - CS1_EN - Enables the CS1 input to be included during the sampling cycle.

5.8 Sensor Configuration Register

Table 5.11 Sensor Configuration Register

ADDR	R/W	REGISTER	B7	B6	B5	B4	B3	B2	B1	B0	DEFAULT
22h	R/W	Sensor Configuration	MAX_DUR[3:0]				RPT_RATE[3:0]				A4h

Datasheet

The Sensor Configuration Register controls timings associated with the Capacitive Sensor channels 1 - 8.

Bits 7 - 4 - MAX_DUR[3:0] - (default 1010b) - Determines the maximum time that a sensor is allowed to be touched until the Capacitive Touch sensor is recalibrated as shown in [Table 5.12](#).

Table 5.12 MAX_DUR Bit Decode

MAX_DUR[3:0]				TIME BEFORE RECALIBRATION
3	2	1	0	
0	0	0	0	560ms
0	0	0	1	840ms
0	0	1	0	1120ms
0	0	1	1	1400ms
0	1	0	0	1680ms
0	1	0	1	2240ms
0	1	1	0	2800ms
0	1	1	1	3360ms
1	0	0	0	3920ms
1	0	0	1	4480ms
1	0	1	0	5600ms
1	0	1	1	6720ms
1	1	0	0	7840ms
1	1	0	1	8906ms
1	1	1	0	10080ms
1	1	1	1	11200ms

Bits 3 - 0 - RPT_RATE[3:0] - (default 0100b) Determines the time duration between interrupt assertions when auto repeat is enabled. The resolution is 35ms the range is from 35ms to 560ms as shown in [Table 5.13](#).

Table 5.13 RPT_RATE Bit Decode

RPT_RATE[3:0] OR M_PRESS[3:0]				INTERRUPT REPEAT RATE OR M_PRESS TIME
3	2	1	0	
0	0	0	0	35ms
0	0	0	1	70ms
0	0	1	0	105ms
0	0	1	1	140ms
0	1	0	0	175ms

Table 5.13 RPT_RATE Bit Decode (continued)

RPT_RATE[3:0] OR M_PRESS[3:0]				INTERRUPT REPEAT RATE OR M_PRESS TIME
3	2	1	0	
0	1	0	1	210ms
0	1	1	0	245ms
0	1	1	1	280ms
1	0	0	0	315ms
1	0	0	1	350ms
1	0	1	0	385ms
1	0	1	1	420ms
1	1	0	0	455ms
1	1	0	1	490ms
1	1	1	0	525ms
1	1	1	1	560ms

5.9 Sensor Configuration 2 Register

Table 5.14 Sensor Configuration 2 Register

ADDR	R/W	REGISTER	B7	B6	B5	B4	B3	B2	B1	B0	DEFAULT
23h	R/W	Sensor Configuration 2	-	-	-	-	M_PRESS[3:0]			07h	

Bits 3- 0 - M_PRESS[3:0] - (default 0111b) - Determines the minimum amount of time that sensors configured to use auto repeat must detect a sensor touch to detect a “press and hold” event. If the sensor detects a touch for longer than the M_PRESS[3:0] settings, then a “press and hold” event is detected.

This is the maximum amount of time that sensors can detect a sensor touch to differentiate between a “touch” and a “press and hold”. If a sensor detects a touch for less than or equal to the M_PRESS[3:0] settings, then a touch event is detected.

The resolution is 35ms the range is from 35ms to 560ms as shown in [Table 5.13](#).

5.10 Averaging and Sampling Configuration Register

Table 5.15 Averaging and Sampling Configuration Register

ADDR	R/W	REGISTER	B7	B6	B5	B4	B3	B2	B1	B0	DEFAULT
24h	R/W	Averaging and Sampling Config			AVG[2:0]			SAMP_TIME	CYCLE_TIME [1:0]		1Dh

Datasheet

The Averaging and Sampling Configuration register controls the number of samples taken and the total sensor cycle time for all active sensors while the device is functioning normally.

Bits 5 - 3 - AVG[2:0] - Determines the number of samples that are taken for all active channels during the sensor cycle as shown in [Table 5.16](#). All samples are taken consecutively on the same channel before the next channel is sampled and the result is averaged over the number of samples measured before updating the measured results.

For example, if CS1, CS2, and CS3 are sampled during the sensor cycle, and the AVG[2:0] bits are set to take 4 samples per channel, then the full sensor cycle will be: CS1, CS1, CS1, CS1, CS2, CS2, CS2, CS2, CS3, CS3, CS3, CS3.

Table 5.16 AVG Bit Decode

AVG[2:0]			NUMBER OF SAMPLES TAKEN PER MEASUREMENT
2	1	0	
0	0	0	1
0	0	1	2
0	1	0	4
0	1	1	8 (default)
1	0	0	16
1	0	1	32
1	1	0	64
1	1	1	128

Bit 2 - SAMP_TIME - Determines the time to take a single sample.

- '0' - The sampling time is ~2.56ms.
- '1' (default) - The sampling time is ~1.28ms.

Bits 1 - 0 - CYCLE_TIME[1:0] - Determines the overall cycle time for all measured channels during normal operation as shown in [Table 5.17](#). All measured channels are sampled at the beginning of the cycle time. If additional time is remaining, then the device is placed into a lower power state for the remaining duration of the cycle.

Table 5.17 CYCLE_TIME Bit Decode

CYCLE_TIME[1:0]		OVERALL CYCLE TIME
1	0	
0	0	35ms
0	1	70ms (default)
1	0	105ms
1	1	140ms

APPLICATION NOTE: The programmed cycle time is only maintained if the total averaging time for all samples is less than the programmed cycle. The AVG[2:0] bits will take priority so that if more samples

are required than would normally be allowed during the cycle time, the cycle time will be extended as necessary to accommodate the number of samples to be measured.

5.11 Calibration Activate Registers

Table 5.18 Calibration Activate Registers

ADDR	R/W	REGISTER	B7	B6	B5	B4	B3	B2	B1	B0	DEFAULT
26h	R/W	Calibration Activate	CS8_CAL	CS7_CAL	CS6_CAL	CS5_CAL	CS4_CAL	CS3_CAL	CS2_CAL	CS1_CAL	FFh

The Calibration Activate register force the respective sensors to be re-calibrated. When a bit is set, the corresponding Capacitive Touch Sensor will be re-calibrated and the bit will be automatically cleared once the re-calibration routine has finished. During the re-calibration routine, the sensors will not detect a press for up to 600ms and the Sensor Base Count register values will be invalid. During this time, any press on the corresponding sensors will invalidate the re-calibration.

Bit 7 - CS8_CAL - When set, the CS8 input is re-calibrated. This bit is automatically cleared once the sensor has been re-calibrated successfully.

Bit 6 - CS7_CAL - When set, the CS7 input is re-calibrated. This bit is automatically cleared once the sensor has been re-calibrated successfully.

Bit 5 - CS6_CAL - When set, the CS6 input is re-calibrated. This bit is automatically cleared once the sensor has been re-calibrated successfully.

Bit 4 - CS5_CAL - When set, the CS5 input is re-calibrated. This bit is automatically cleared once the sensor has been re-calibrated successfully.

Bit 3 - CS4_CAL - When set, the CS4 input is re-calibrated. This bit is automatically cleared once the sensor has been re-calibrated successfully.

Bit 2 - CS3_CAL - When set, the CS3 input is re-calibrated. This bit is automatically cleared once the sensor has been re-calibrated successfully.

Bit 1 - CS2_CAL - When set, the CS2 input is re-calibrated. This bit is automatically cleared once the sensor has been re-calibrated successfully.

Bit 0 - CS1_CAL - When set, the CS1 input is re-calibrated. This bit is automatically cleared once the sensor has been re-calibrated successfully.

5.12 Interrupt Enable Register

Table 5.19 Interrupt Enable Register

ADDR	R/W	REGISTER	B7	B6	B5	B4	B3	B2	B1	B0	DEFAULT
27h	R/W	Interrupt Enable	CS8_INT_EN	CS7_INT_EN	CS6_INT_EN	CS5_INT_EN	CS4_INT_EN	CS3_INT_EN	CS2_INT_EN	CS1_INT_EN	FFh

The Interrupt Enable registers determine whether a sensor touch or release causes the interrupt pin to be asserted.

Bit 7 - CS8_INT_EN - Enables the interrupt pin to be asserted if a touch is detected on CS8 (associated with the CS8 status bit).

Datasheet

- '0' - The interrupt pin will not be asserted if a touch is detected on CS8 (associated with the CS8 status bit).
- '1' (default) - The interrupt pin will be asserted a touch is detected on CS8 (associated with the CS8 status bit).

Bit 6 - CS7_INT_EN - Enables the interrupt pin to be asserted if a touch is detected on CS7 (associated with the CS7 status bit).

Bit 5 - CS6_INT_EN - Enables the interrupt pin to be asserted if a touch is detected on CS6 (associated with the CS6 status bit).

Bit 4 - CS5_INT_EN - Enables the interrupt pin to be asserted if a touch is detected on CS5 (associated with the CS5 status bit).

Bit 3 - CS4_INT_EN - Enables the interrupt pin to be asserted if a touch is detected on CS4 (associated with the CS4 status bit).

Bit 2 - CS3_INT_EN - Enables the interrupt pin to be asserted if a touch is detected on CS3 (associated with the CS3 status bit).

Bit 1 - CS2_INT_EN - Enables the interrupt pin to be asserted if a touch is detected on CS2 (associated with the CS2 status bit).

Bit 0 - CS1_INT_EN - Enables the interrupt pin to be asserted if a touch is detected on CS1 (associated with the CS1 status bit).

5.13 Repeat Rate Enable Register

Table 5.20 Repeat Rate Enable Register

ADDR	R/W	REGISTER	B7	B6	B5	B4	B3	B2	B1	B0	DEFAULT
28h	R/W	Repeat Rate Enable	CS8_RPT_EN	CS7_RPT_EN	CS6_RPT_EN	CS5_RPT_EN	CS4_RPT_EN	CS3_RPT_EN	CS2_RPT_EN	CS1_RPT_EN	FFh

The Repeat Rate Enable register determines the interrupt behavior of the buttons as described in [Section 4.6.1](#).

Bit 7 - CS8_RPT_EN - Enables the repeat rate for Capacitive Touch Sensor 8.

- '0' - The repeat rate for CS8 is disabled. It will only generate an interrupt when a touch is detected and when a release is detected no matter how long the touch is held for.
- '1' (default) - The repeat rate for CS8 is enabled. In the case of a "touch" event, it will generate an interrupt when a touch is detected and a release is detected. In the case of a "press and hold" event, it will generate an interrupt when a touch is detected and at the repeat rate so long as the touch is held. It will not generate an interrupt when a release is detected.

Bit 6 - CS7_RPT_EN - Enables the repeat rate for Capacitive Touch Sensor 7.

Bit 5 - CS6_RPT_EN - Enables the repeat rate for Capacitive Touch Sensor 6.

Bit 4 - CS5_RPT_EN - Enables the repeat rate for Capacitive Touch Sensor 5.

Bit 3 - CS4_RPT_EN - Enables the repeat rate for Capacitive Touch Sensor 4.

Bit 2 - CS3_RPT_EN - Enables the repeat rate for Capacitive Touch Sensor 3.

Bit 1 - CS2_RPT_EN - Enables the repeat rate for Capacitive Touch Sensor 2.

Bit 0 - CS1_RPT_EN - Enables the repeat rate for Capacitive Touch Sensor 1.

5.14 Multiple Touch Configuration Register

Table 5.21 Multiple Touch Configuration

ADDR	R/W	REGISTER	B7	B6	B5	B4	B3	B2	B1	B0	DEFAULT
2Ah	R/W	Multiple Touch Config	MULT_BLK_EN	-	-	-	B_MULT_T[1:0]		-	-	80h

The Multiple Touch Configuration register controls the settings for the multiple touch detection circuitry. These settings determine the number of simultaneous buttons that may be pressed before action is taken.

Bit 7 - MULT_BLK_EN - Enables the multiple button blocking circuitry.

- '0' - The multiple touch circuitry is disabled. The device will not block multiple touches.
- '1' (default) - The multiple touch circuitry is enabled. The device will accept the number of touches equal to programmed multiple touch threshold and block all others. It will remember which sensor is valid and block all others until that sensor has been released.

Bits 3 - 2 - B_MULT_T[1:0] - Determines the number of simultaneous touches on all sensors before a Multiple Touch Event is detected and sensors are blocked. The bit decode is given by [Table 5.22](#).

Table 5.22 B_MULT_T Bit Decode

B_MULT_T[1:0]		NUMBER OF SIMULTANEOUS TOUCHES
1	0	
0	0	1 (default)
0	1	2
1	0	3
1	1	4

5.15 Recalibration Configuration Register

Table 5.23 Recalibration Configuration Registers

ADDR	R/W	REGISTER	B7	B6	B5	B4	B3	B2	B1	B0	DEFAULT
2Fh	R/W	Recalibration Configuration	BUT_LD_TH	-	-	NEG_DELTA_CNT[1:0]		CAL_CFG[2:0]			8Bh

The Recalibration Configuration register controls the automatic re-calibration routine settings as well as advanced controls to program the Sensor Threshold register settings.

Bit 7 - BUT_LD_TH - Enables setting all Sensor Threshold registers by writing to the Sensor 1 Threshold register.

- '0' - Each Sensor X Threshold register is updated individually.
- '1' (default) - Writing the Sensor 1 Threshold register will automatically overwrite the Sensor Threshold registers for all sensors (Sensor Threshold 1 through Sensor Threshold 8). The

Datasheet

individual Sensor X Threshold registers (Sensor 2 Threshold through Sensor 8 Threshold) can be individually updated at any time.

Bits 4 - 3 - NEG_DELTA_CNT[1:0] - Determines the number of negative delta counts necessary to trigger a digital re-calibration as shown in [Table 5.24](#).

Table 5.24 NEG_DELTA_CNT Bit Decode

NEG_DELTA_CNT[1:0]		NUMBER OF CONSECUTIVE NEGATIVE DELTA COUNT VALUES
1	0	
0	0	8
0	1	16 (default)
1	0	32
1	1	None (disabled)

Bits 2 - 0 - CAL_CFG[2:0] - Determines the update time and number of samples of the automatic re-calibration routine. The settings applies to all sensors universally (though individual sensors can be configured to support re-calibration - see [Section 5.11](#)).

Table 5.25 CAL_CFG Bit Decode

CAL_CFG[2:0]			RECALIBRATION SAMPLES (SEE Note 5.1)	UPDATE TIME (SEE Note 5.2)
2	1	0		
0	0	0	16	16
0	0	1	32	32
0	1	0	64	64
0	1	1	256	256 (default)
1	0	0	256	1024
1	0	1	256	2048
1	1	0	256	4096
1	1	1	256	7936

Note 5.1 Recalibration Samples refers to the number of samples that are measured and averaged before the Base Count is updated however does not control the base count update period. Once this target number of update cycles is reached, the device may wait additional time as determined by the Update Time before the base count is updated as determined by the settings.

Note 5.2 Update Time refers to the amount of time (in polling cycle periods) that elapses before the Base Count is updated. For those settings that have the Update Time greater than the Recalibration Samples value, the device will wait (and continue to average the updated base count) until the Update Time has elapsed before the base count is updated.

5.16 Sensor Threshold Registers

Table 5.26 Sensor Threshold Registers

ADDR	R/W	REGISTER	B7	B6	B5	B4	B3	B2	B1	B0	DEFAULT
30h	R/W	Sensor 1 Threshold	-	64	32	16	8	4	2	1	40h
31h	R/W	Sensor 2 Threshold	-	64	32	16	8	4	2	1	40h
32h	R/W	Sensor 3 Threshold	-	64	32	16	8	4	2	1	40h
33h	R/W	Sensor 4 Threshold	-	64	32	16	8	4	2	1	40h
34h	R/W	Sensor 5 Threshold	-	64	32	16	8	4	2	1	40h
35h	R/W	Sensor 6 Threshold	-	64	32	16	8	4	2	1	40h
36h	R/W	Sensor 7 Threshold	-	64	32	16	8	4	2	1	40h
37h	R/W	Sensor 8 Threshold	-	64	32	16	8	4	2	1	40h

The Sensor Threshold registers store the delta threshold that is used to determine if a touch has been detected. When a touch occurs, the input signal of the corresponding sensor changes due to the capacitance associated with a touch. If the sensor input change exceeds the threshold settings, then a touch is detected.

When the BUT_LD_TH bit is set (see [Section 5.15](#) - bit 7), writing data to the Sensor 1 Threshold register will update all of the sensor threshold registers (31h - 37h inclusive).

5.17 Sensor Noise Threshold Registers

Table 5.27 Sensor Noise Threshold Registers

ADDR	R/W	REGISTER	B7	B6	B5	B4	B3	B2	B1	B0	DEFAULT
38h	R/W	Sensor Noise Threshold 1	CS4_BN_TH [1:0]		CS3_BN_TH [1:0]		CS2_BN_TH [1:0]		CS1_BN_TH [1:0]		55h
39h	R/W	Sensor Noise Threshold 2	CS8_BN_TH [1:0]		CS7_BN_TH [1:0]		CS6_BN_TH [1:0]		CS5_BN_TH [1:0]		55h

The Sensor Noise Threshold registers control the value of a secondary internal threshold to detect noise and improve the automatic recalibration routine. If a Capacitive Touch Sensor output exceeds the Sensor Noise Threshold but does not exceed the sensor threshold, then it is determined to be caused by a noise spike. That sample is not used by the automatic re-calibration routine.

The Sensor Noise Threshold is proportional to the programmed threshold as shown in [Table 5.28](#).

Table 5.28 CSx_BN_TH Bit Decode

CSX_BN_TH[1:0]		THRESHOLD DIVIDE SETTING
1	0	
0	0	25%
0	1	37.5% (default)
1	0	50%
1	1	62.5%

5.17.1 Sensor Noise Threshold 1 Register

The Sensor Noise Threshold 1 register controls the noise threshold for Capacitive Touch Sensors 1-4.

Bits 7-6 - CS4_BN_TH[1:0] - Controls the noise threshold for Capacitive Touch Sensor 4.

Bits 5-4 - CS3_BN_TH[1:0] - Controls the noise threshold for Capacitive Touch Sensor 3.

Bits 3-2 - CS2_BN_TH[1:0] - Controls the noise threshold for Capacitive Touch Sensor 2.

Bits 1-0 - CS1_BN_TH[1:0] - Controls the noise threshold for Capacitive Touch Sensor 1.

5.17.2 Sensor Noise Threshold 2 Register

The Sensor Noise Threshold 2 register controls the noise threshold for Capacitive Touch Sensors 5 - 8.

Bits 7-6 - CS8_BN_TH[1:0] - Controls the noise threshold for Capacitive Touch Sensor 8.

Bits 5-4 - CS7_BN_TH[1:0] - Controls the noise threshold for Capacitive Touch Sensor 7.

Bits 3-2 - CS6_BN_TH[1:0] - Controls the noise threshold for Capacitive Touch Sensor 6.

Bits 1-0 - CS5_BN_TH[1:0] - Controls the noise threshold for Capacitive Touch Sensor 5.

5.18 Standby Channel Register

Table 5.29 Standby Channel Register

ADDR	R/W	REGISTER	B7	B6	B5	B4	B3	B2	B1	B0	DEFAULT
40h	R/W	Standby Channel	CS8_STBY	CS7_STBY	CS6_STBY	CS5_STBY	CS4_STBY	CS3_STBY	CS2_STBY	CS1_STBY	00h

The Standby Channel register controls which (if any) Capacitive Touch Sensors are active during Standby.

Bit 7 - CS8_STBY - Controls whether the CS8 channel is active in Standby.

- '0' (default) - The CS8 channel not be sampled during Standby.
- '1' - The CS8 channel will be sampled during Standby. It will use the Standby threshold setting, and the standby averaging and sensitivity settings.

Bit 6 - CS7_STBY - Controls whether the CS7 channel is active in Standby.

Bit 5 - CS6_STBY - Controls whether the CS6 channel is active in Standby.

Bit 4 - CS5_STBY - Controls whether the CS5 channel is active in Standby.

Bit 3 - CS4_STBY - Controls whether the CS4 channel is active in Standby.

Bit 2 - CS3_STBY - Controls whether the CS3 channel is active in Standby.

Bit 1 - CS2_STBY - Controls whether the CS2 channel is active in Standby.

Bit 0 - CS1_STBY - Controls whether the CS1 channel is active in Standby.

5.19 Standby Configuration Register

Table 5.30 Standby Configuration Register

ADDR	R/W	REGISTER	B7	B6	B5	B4	B3	B2	B1	B0	DEFAULT
41h	R/W	Standby Configuration	AVG_SUM	-	STBY_AVG[2:0]			STBY_SAMP_TIME	STBY_CY_TIME [1:0]		1Dh

The Standby Configuration register controls averaging and cycle time for those sensors that are active in Standby.

Bit 7 - AVG_SUM - Determines whether the active sensors will average the programmed number of samples or whether they will accumulate for the programmed number of samples.

- '0' - (default) - The active sensor delta count values will be based on the average of the programmed number of samples when compared against the threshold.
- '1' - The active sensor delta count values will be based on the summation of the programmed number of samples when compared against the threshold.

Bits 5 - 3 - STBY_AVG[2:0] - Determines the number of samples that are taken for all active channels during the sensor cycle as shown in [Table 5.31](#). All samples are taken consecutively on the same channel before the next channel is sampled and the result is averaged over the number of samples measured before updating the measured results.

Table 5.31 STBY_AVG Bit Decode

STBY_AVG[2:0]			NUMBER OF SAMPLES TAKEN PER MEASUREMENT
2	1	0	
0	0	0	1
0	0	1	2
0	1	0	4
0	1	1	8 (default)
1	0	0	16
1	0	1	32
1	1	0	64
1	1	1	128

Bit 2 - STBY_SAMP_TIME - Determines the time to take a single sample when the device is in Standby.

Datasheet

- '0' - The sampling time is ~2.56ms.
- '1' (default) - The sampling time is ~1.28ms.

Bits 1 - 0 - STBY_CY_TIME[2:0] - Determines the overall cycle time for all measured channels during normal operation as shown in [Table 5.17](#). All measured channels are sampled at the beginning of the cycle time. If additional time is remaining, then the device is placed into a lower power state for the remaining duration of the cycle.

Table 5.32 STBY_CY_TIME Bit Decode

STBY_CY_TIME[1:0]		OVERALL CYCLE TIME
1	0	
0	0	35ms
0	1	70ms (default)
1	0	105ms
1	1	140ms

APPLICATION NOTE: The programmed cycle time is only maintained if the total averaging time for all samples is less than the programmed cycle. The STBY_AVG[2:0] bits will take priority so that if more samples are required than would normally be allowed during the cycle time, the cycle time will be extended as necessary to accommodate the number of samples to be measured.

5.20 Standby Sensitivity Register

Table 5.33 Standby Configuration Register

ADDR	R/W	REGISTER	B7	B6	B5	B4	B3	B2	B1	B0	DEFAULT
42h	R/W	Standby Sensitivity	-	-	-	-	-	STBY_SENSE[2:0]			02h

The Standby Sensitivity register controls the sensitivity for sensors that are active in Standby.

Bits 2 - 0 - STBY_SENSE[2:0] - Controls the sensitivity for sensors that are active in Standby. The sensitivity settings act to scale the relative delta count value higher or lower based on the system parameters. A setting of 000b is the most sensitive while a setting of 111b is the least sensitive. At the more sensitive settings, touches are detected for a smaller delta C corresponding to a "lighter" touch. These settings are more sensitive to noise however and a noisy environment may flag more false touches than higher sensitivity levels.

APPLICATION NOTE: A value of 128x is the most sensitive setting available. At the most sensitivity settings, the MSB of the Delta Count register represents 64 out of ~25,000 which corresponds to a touch of approximately 0.25% of the base capacitance (or a ΔC of 25fF from a 10pF base capacitance). Conversely a value of 1x is the least sensitive setting available. At these settings, the MSB of the Delta Count register corresponds to a delta count of 8192 counts out of ~25,000 which corresponds to a touch of approximately 33% of the base capacitance (or a ΔC of 3.33pF from a 10pF base capacitance).

Table 5.34 STBY_SENSE Bit Decode

STBY_SENSE[2:0]			SENSITIVITY MULTIPLIER
2	1	0	
0	0	0	128x (most sensitive)
0	0	1	64x
0	1	0	32x (default)
0	1	1	16x
1	0	0	8x
1	0	1	4x
1	1	0	2x
1	1	1	1x - (least sensitive)

5.21 Standby Threshold Register

Table 5.35 Standby Threshold Register

ADDR	R/W	REGISTER	B7	B6	B5	B4	B3	B2	B1	B0	DEFAULT
43h	R/W	Standby Threshold	-	64	32	16	8	4	2	1	40h

The Standby Threshold registers stores the delta threshold that is used to determine if a touch has been detected. When a touch occurs, the input signal of the corresponding sensor changes due to the capacitance associated with a touch. If the sensor input change exceeds the threshold settings, then a touch is detected.

5.22 Sensor Base Count Registers

Table 5.36 Sensor Base Count Registers

ADDR	R/W	REGISTER	B7	B6	B5	B4	B3	B2	B1	B0	DEFAULT
50h	R	Sensor 1 Base Count	128	64	32	16	8	4	2	1	C8h
51h	R	Sensor 2 Base Count	128	64	32	16	8	4	2	1	C8h
52h	R	Sensor 3 Base Count	128	64	32	16	8	4	2	1	C8h
53h	R	Sensor 4 Base Count	128	64	32	16	8	4	2	1	C8h
54h	R	Sensor 5 Base Count	128	64	32	16	8	4	2	1	C8h

Table 5.36 Sensor Base Count Registers (continued)

ADDR	R/W	REGISTER	B7	B6	B5	B4	B3	B2	B1	B0	DEFAULT
55h	R	Sensor 6 Base Count	128	64	32	16	8	4	2	1	C8h
56h	R	Sensor 7 Base Count	128	64	32	16	8	4	2	1	C8h
57h	R	Sensor 8 Base Count	128	64	32	16	8	4	2	1	C8h

The Sensor Base Count registers store the calibrated “Not Touched” input value from the Capacitive Touch Sensor inputs. These registers are periodically updated by the re-calibration routine.

The routine uses an internal adder to add the current count value for each reading to the sum of the previous readings until sample size has been reached. At this point, the upper 16 bits are taken and used as the Sensor Base Count. The internal adder is then reset and the re-calibration routine continues.

The data presented is determined by the BASE_SHIFT[3:0] bits (see [Section 5.5](#)).

5.23 LED Output Type Register

Table 5.37 LED Output Type Register

ADDR	R/W	REGISTER	B7	B6	B5	B4	B3	B2	B1	B0	DEFAULT
71h	R/W	LED Output Type	-	-	-	-	-	-	LED2_OT	LED1_OT	00h

The LED Output Type register controls the type of output for the LED pins. Each pin is controlled by a single bit.

Bit 1 - LED2_OT - Determines the output type of the LED2 pin.

- '0' (default) - The LED2 pin is an open-drain output with an external pull-up resistor. When the appropriate pin is set to the “active” state (logic '1') then the pin will be driven low. Conversely, when the pin is set to the “inactive” state (logic '0', then the pin will be left in a High Z state and pulled high via an external pull-up resistor.
- '1' - The LED2 pin is a push-pull output. When driving a logic '1' the pin is driven high. When driving a logic '0' the pin is driven low.

Bit 0 - LED1_OT - Determines the output type of the LED1 pin.

5.24 Sensor LED Linking Register

Table 5.38 Sensor LED Linking Register

ADDR	R/W	REGISTER	B7	B6	B5	B4	B3	B2	B1	B0	DEFAULT
72h	R/W	Sensor LED Linking	-	-	-	-	-	-	CS2_LED2	CS1_LED1	00h

The Sensor LED Linking registers control whether a Capacitive Touch Sensor is linked to an LED output or not. If the corresponding bit is set, then the appropriate LED output will change states defined by the LED Behavior controls (see [Section 5.27](#)) in response to the Capacitive Touch sensor.

Bit 1 - CS2_LED2 - Links the LED2 output to a detected touch on the CS2 sensor. When a touch is detected, the LED is actuated and will behave as determined by the LED Behavior controls.

- '0' (default) - The LED 2 output is not associated with a the CS2 input. If a touch is detected on the CS2 input, then the LED will not automatically be actuated. The LED is enabled and controlled via the LED Output Configuration register (see [Section 5.24](#)) and the LED Behavior registers (see [Section 5.27](#)).
- '1' - The LED 2 output is associated with the CS2 input. If a touch is detected on the CS2 input then the LED will be actuated and behave as defined in [Table 5.43](#).

Bit 0 - CS1_LED1 - Links the LED1 output to a detected touch on the CS1 sensor. When a touch is detected, the LED is actuated and will behave as determined by the LED Behavior controls.

5.25 LED Polarity Register

Table 5.39 LED Polarity Register

ADDR	R/W	REGISTER	B7	B6	B5	B4	B3	B2	B1	B0	DEFAULT
73h	R/W	LED Polarity	-	-	-	-	-	-	LED2_ POL	LED1_ POL	00h

The LED Polarity registers control the logical polarity of the LED outputs.

APPLICATION NOTE: The polarity controls determine the final LED pin drive. A touch on a linked Capacitive Touch Sensor is treated in the same way as the LED Output Control bit being set to a logic '1'.

APPLICATION NOTE: For LED operation, the duty cycle settings determine the % of time that the LED pin will be driven to a logic '1' state in a non-inverted system or to a logic '0' state in an inverted system. The duty cycle settings operate independently of the polarity controls. Therefore, the Max Duty Cycle settings define the maximum % of time that the LED pin will be driven high in a non-inverted system while the Min Duty Cycle settings determine the minimum % of time that the LED pin will be driven high in a non-inverted system.

The LED drive assumes that the LEDs are configured such that if the LED pin is driven to a logic '0' then the LED will be on and that the CAP1028 LED pin is sinking the LED current. Conversely, if the LED pin is driven to a logic '1' then the LED will be off and there is no current flow.

Finally, the breathe operations will always ramp the duty cycle from the minimum duty cycle to the maximum duty cycle and then back down to the minimum duty cycle.

The LED Polarity controls lead to two conditions that have the apparent effect of changing the duty cycle settings. If an LED output is non-inverted then the Maximum Duty Cycle settings will define the maximum % of time that the LED is **off**. Conversely the Minimum Duty Cycle settings will define the minimum % of time that the LED is **off**. As well, when there is no touch detected or the LED Output Control register bit is at a logic '0' then the LED output will be driven at the minimum duty cycle setting. The relative brightness will then ramp from maximum to minimum and back.

If an LED output is inverted, then the Maximum Duty Cycle settings will define the maximum % of time that the LED is **on** and the Minimum Duty Cycle settings will determine the minimum % of time that the LED is **on**. As well, when there is no touch detected, or the LED Output Control register bit is at a logic '0', then the LED output will be driven at the minimum duty cycle setting. The relative brightness will then ramp from minimum to maximum and back.

Bit 1 - LED2_POL - Determines the polarity of the LED2 output.

Datasheet

- '0' - The LED2 output is inverted. A setting of '1' in the LED Output register will cause the output to be driven to a logic '0' as determined by the LED behavior. Similarly, the duty cycles corresponding to Pulse and Breathe operations will indicate the amount of time that the LED is driven to a logic '0' state (corresponding to "active").
- '1' - The LED2 output is non-inverted. A setting of '1' in the LED Output register will cause the output to be driven to a logic '1' or left in the high-z state as determined by its output type and LED behavior. Similarly, the duty cycles corresponding to Pulse and Breathe operations will indicate to the amount of time that the LED is driven to a logic '1' state (corresponding to "inactive").

Bit 0 - LED1_POL - Determines the polarity of the LED1 output.

5.26 LED Output Control Register

Table 5.40 LED Output Control Register

ADDR	R/W	REGISTER	B7	B6	B5	B4	B3	B2	B1	B0	DEFAULT
74h	R/W	LED Output Control	-	-	-	-	-	-	LED2_DR	LED1_DR	00h

The LED Output Control Register controls the output state of the LED pins.

All LEDs that are associated with a Capacitive Touch Sensor channel are automatically enabled and will be actuated per the LED Behavior.

For those LEDs that are not linked with a Capacitive Touch Sensor channel, then the bit state determines whether the LED is actuated or not actuated.

The LED Polarity Control register will determine the non actuated state of the LED pins.

Table 5.41 shows the interaction between the polarity controls, output controls and relative brightness.

Table 5.41 LED Polarity Behavior

LED OUTPUT CONTROL REGISTER	POLARITY	MAX DUTY	MIN DUTY	LED BEHAVIORS	BRIGHTNESS	LED APPEARANCE
0	inverted	maximum % of time that the LED is on (logic 0)	minimum % of time that the LED is on (logic 0)	off	maximum brightness at minimum duty cycle	on at minimum duty cycle
1	inverted	maximum % of time that the LED is on (logic 0)	minimum % of time that the LED is on (logic 0)	on	maximum brightness at max duty cycle. Brightness ramps from min to max	according to LED behavior
0	non-inverted	maximum % of time that the LED is off (logic 1)	minimum % of time that the LED is off (logic 1)	off	maximum brightness at 100 - min duty cycle	on at 100 - min duty cycle (Note 5.3)
1	non-inverted	maximum % of time that the LED is off (logic 1)	minimum % of time that the LED is off (logic 1)	on	maximum brightness at 100 - min duty cycle. Brightness ramps from max to min	according to LED behavior

Note 5.3 For example: when polarity is non-inverted, if min duty cycle is 0, then the LED would be at logic 1 (off) 0% of the time. It will be at logic 0 (on), 100% of the time (100 - min duty cycle).

Bit 1 - LED2_DR - Determines whether LED2 output is driven high or low.

- '0' (default) - The LED2 output is driven at the minimum duty cycle or not actuated.
- '1' - The LED2 output is High Z or driven at the maximum duty cycle or actuated.

Bit 0 - LED1_DR - Determines whether LED1 output is driven high or low.

5.27 LED Behavior Registers

Table 5.42 LED Behavior Registers

ADDR	R/W	REGISTER	B7	B6	B5	B4	B3	B2	B1	B0	DEFAULT
81h	R/W	LED Behavior	-	-	-	-	LED2_CTL[1:0]		LED1_CTL[1:0]		00h

The LED Behavior registers control the operation of LEDs. Each LED pin is controlled by a 2-bit field and the behavior is determined by whether the LED is linked to a Capacitive Touch Sensor or not.

If the corresponding LED output is linked to a Capacitive Touch Sensor than the Start and Stop triggers are used. The defined behavior will activate when the Start Trigger is met and will stop when the Stop Trigger is met.

If the LED output is not associated with a a Capacitive Touch Sensor, then the appropriate behavior will be enabled / disabled by the LED Output Control register. If the respective LEDx_DR bit is set to a logic '1' then this will be associated as a "touch" and if the LEDx_DR bit is set to a logic '0' then this will be associated as a "release".

The LED Polarity Control register will determine the non actuated state of the LED outputs. If the LED Polarity Control register is set to be inverted (default), then an non actuated LED pin will be driven to a logic '1' state and the LED will be off. If the LED Polarity Control register is set to be non-inverted, then the non actuated LED pin will be driven to the logic '0' state and the LED will be on.

APPLICATION NOTE: If an LED is not linked to a Capacitive Touch Sensor and is breathing (via the Breathe or Pulse behaviors), it will finish its current "breath" before any changes to behavior are processed.

APPLICATION NOTE: If an LED is not linked to the Capacitive Touch Sensor and configured to operate using Pulse 1 Behavior, then the circuitry will only be actuated when the corresponding bit is set. It will not check the bit condition until the Pulse 1 behavior is finished. The device will not remember if the bit was cleared and reset while it was actuated.

APPLICATION NOTE: If an LED is actuated and it is switched from linked to a Capacitive Touch Sensor to unlinked (or vice versa), then the LED will respond to the new command source immediately. For example, if a linked LED was actuated by a touch and the control is changed so that it is unlinked, it will check the status of the corresponding LED Output Control bit. If that bit is '0', then the LED will behave as if a release was detected. Likewise, if an unlinked LED was actuated by the LED Output Control register and the control is changed so that it is linked and no touch is detected, then the LED will behave as if a release was detected.

APPLICATION NOTE: If the period for any breathe operation is changed while the LED is actuated, then the LED output will be reset to 0% drive and any breathing will re-initiate at the new settings. For Pulse 1 and Pulse 2 behaviors, the number of pulses will be retained.

Bits 3 - 2 - LED2_CTL[1:0] - Determines the behavior of LED2 as shown in [Table 5.43](#).

Bits 1 - 0 - LED1_CTL[1:0] - Determines the behavior of LED1 as shown in [Table 5.43](#).

Table 5.43 LEDx_CTL Bit Decode

LEDX_CTL [1:0]		OPERATION	DESCRIPTION	START TRIGGER	STOP TRIGGER
1	0				
0	0	Direct	The LED is driven to the programmed state (active or inactive). See Figure 5.5	Touch Detected or LED Control bit set	Release Detected or LED Control bit cleared
0	1	Pulse 1	The LED will "Pulse" a programmed number of times. During each "Pulse" the LED will breathe up to the maximum brightness and back down to the minimum brightness so that the total "Pulse" period matches the programmed value.	Touch or Release Detected (See Section 5.31) or LED Control bit set	n/a
1	0	Pulse 2	The LED will Breathe when the start trigger is detected. When the stop trigger is detected, it will "Pulse" a number of times then return to its minimum brightness.	Touch Detected or LED Control bit set	Release Detected or LED Control bit cleared
1	1	Breathe	The LED will breathe. It will be driven with a duty cycle that ramps up from the programmed minimum duty cycle (default 0%) to the programmed maximum duty cycle (default 100%) and then back down. Each ramp takes up 50% of the programmed period. The total period of each "breath" is determined by the LED Breathe Period controls - see Section 5.30 .	Touch Detected or LED Control bit set	Release Detected or LED Control bit cleared

APPLICATION NOTE: The PWM frequency is determined based on the selected LED behavior, the programmed breathe period, and the programmed min and max duty cycles. For the Direct Mode, the PWM frequency is calculated based on the programmed Rise and Fall times. If these are set at 0, then the maximum PWM frequency will be used based on the programmed duty cycle settings.

5.28 LED Pulse 1 Period Register

Table 5.44 LED Pulse 1 Period Register

ADDR	R/W	REGISTER	B7	B6	B5	B4	B3	B2	B1	B0	DEFAULT
84h	R/W	LED Pulse 1 Period	ST_TRIG	P1_PER6	P1_PER5	P1_PER4	P1_PER3	P1_PER2	P1_PER1	P1_PER0	20h

The LED Pulse Period 1 register determines the overall period of a pulse operation as determined by the LED_CTL registers (see [Table 5.43](#) - setting 01b). Each LSB represents 32ms so that a setting of 14h (20d) would represent a period of 640ms. The total range is from 32ms to 4.06 seconds as shown in [Table 5.45](#).

APPLICATION NOTE: Due to constraints on the LED Drive PWM operation, any Breathe Period less than 160ms (05h) may not be achievable. The device will breathe at the minimum period possible as determined by the period and min / max duty cycle settings.

Bit 7 - ST_TRIG - Determines the start trigger for the LED Pulse behavior.

- '0' (default) - The LED will Pulse when a touch is detected.
- '1' - The LED will Pulse when a release is detected.

The Pulse 1 operation is shown in [Figure 5.1](#) when the LED output is configured for non-inverted polarity and in [Figure 5.2](#) for inverted polarity.

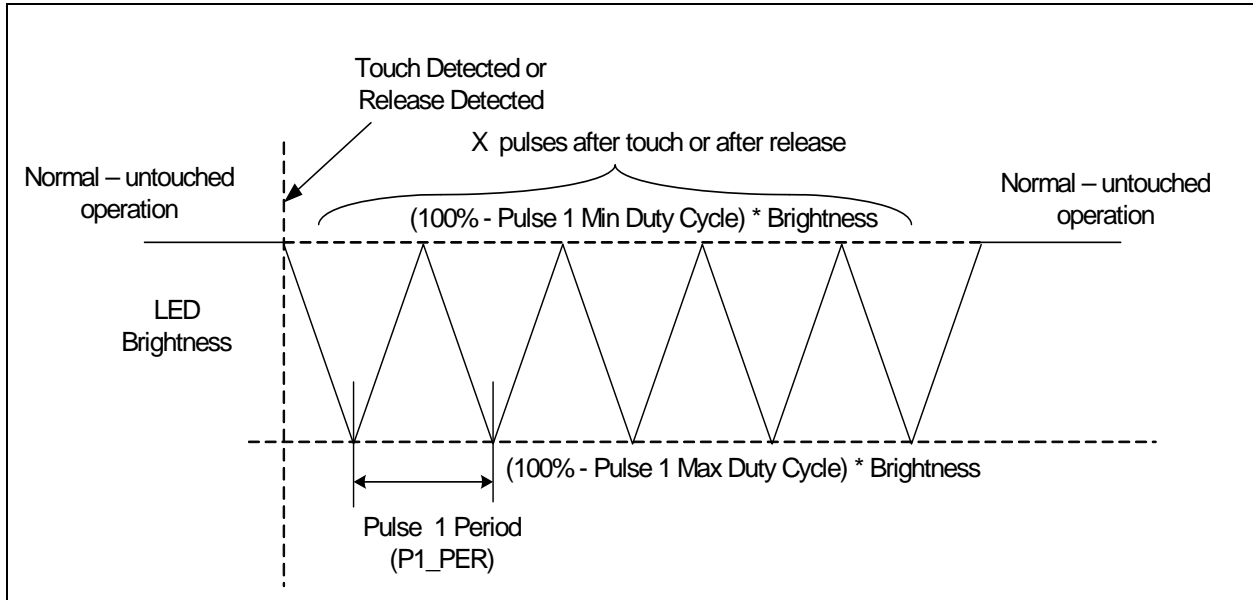

Figure 5.1 Pulse Behavior with Non-Inverted Polarity

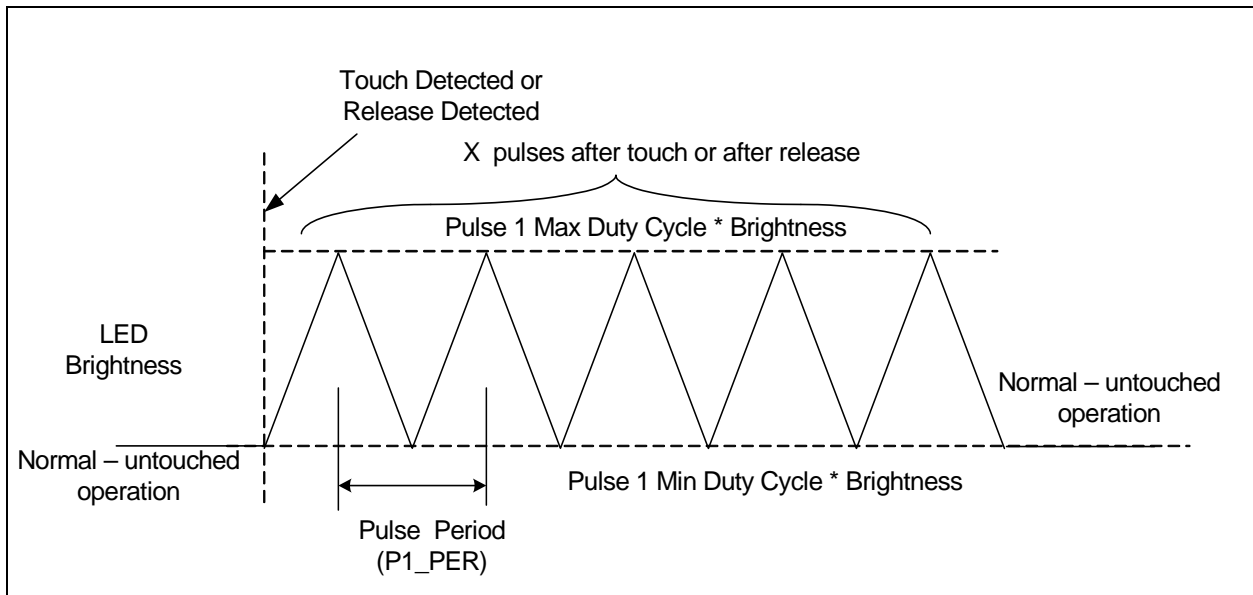

Figure 5.2 Pulse Behavior with Inverted Polarity

Table 5.45 LED Pulse / Breathe Period Example

SETTING (HEX)	SETTING (DECIMAL)	TOTAL BREATHE / PULSE PERIOD (MS)
00h	0	32
01h	1	32
02h	2	64
03h	3	96
04h	4	128
...
7Ch	124	3,968
7Dh	125	4,000
7Eh	126	4,032
7Fh	127	4,064

5.29 LED Pulse 2 Period Register

Table 5.46 LED Pulse 2 Period Register

ADDR	R/W	REGISTER	B7	B6	B5	B4	B3	B2	B1	B0	DEFAULT
85h	R/W	LED Pulse 2 Period	-	P2_PER6	P2_PER5	P2_PER4	P2_PER3	P2_PER2	P2_PER1	P2_PER0	14h

The LED Pulse 2 Period register determines the overall period of a pulse operation as determined by the LED_CTL registers (see [Table 5.43](#) - setting 10b). Each LSB represents 32ms so that a setting of 14h (20d) would represent a period of 640ms. The total range is from 32ms to 4.06 seconds (see [Table 5.45](#)).

APPLICATION NOTE: Due to constraints on the LED Drive PWM operation, any Breathe Period less than 160ms (05h) may not be achievable. The device will breathe at the minimum period possible as determined by the period and min / max duty cycle settings.

The Pulse 2 Behavior is shown in [Figure 5.3](#) for non-inverted polarity and in [Figure 5.4](#) for inverted polarity.

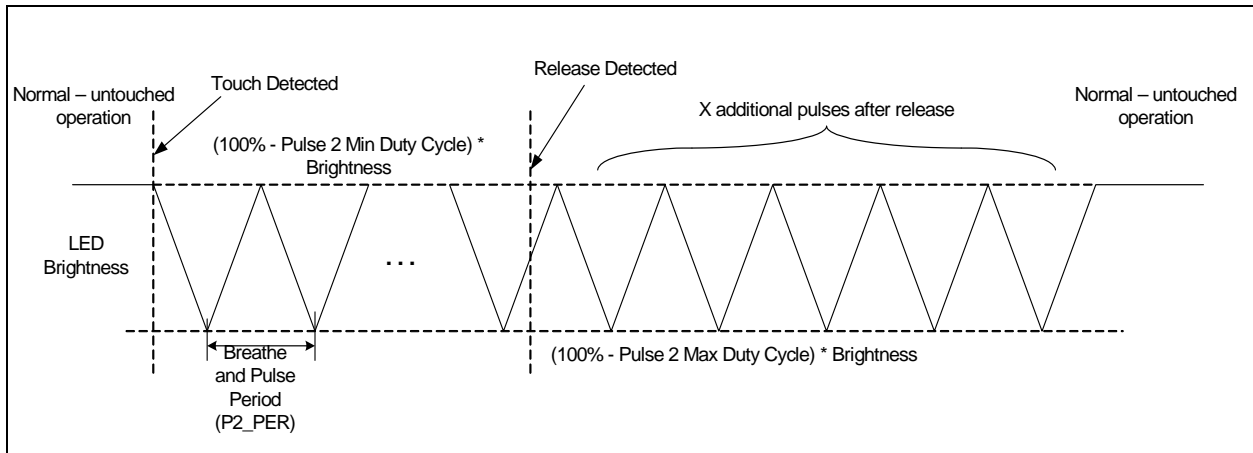
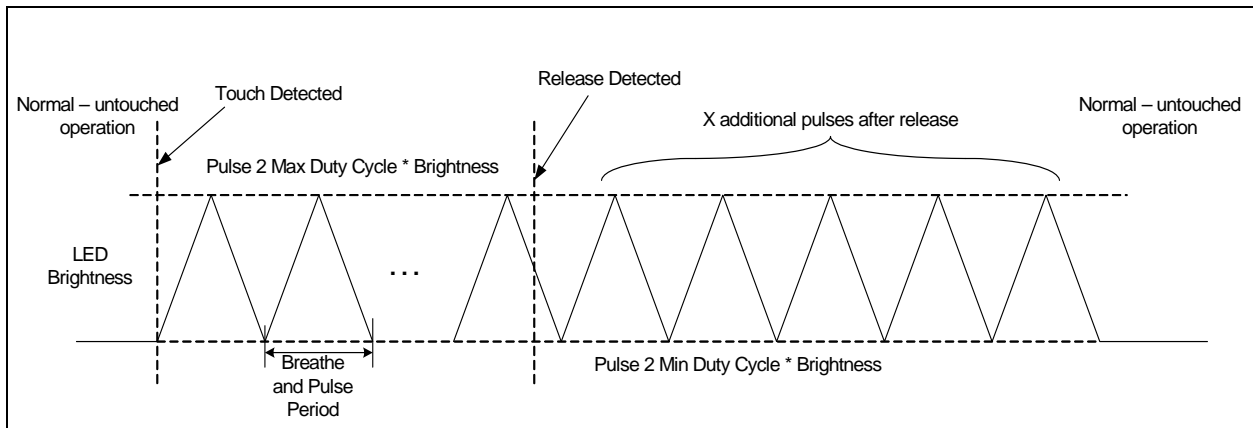
Figure 5.3 Pulse 2 Behavior with Non-Inverted Polarity

Figure 5.4 Pulse 2 Behavior with Inverted Polarity

5.30 LED Breathe Period Register

Table 5.47 LED Breathe Period Register

ADDR	R/W	REGISTER	B7	B6	B5	B4	B3	B2	B1	B0	DEFAULT
86h	R/W	LED Breathe Period	-	BR_PER6	BR_PER5	BR_PER4	BR_PER3	BR_PER2	BR_PER1	BR_PER0	5Dh

The LED Breathe Period register determines the overall period of a breathe operation as determined by the LED_CTL registers (see [Table 5.43](#) - setting 11b). Each LSB represents 32ms so that a setting of 14h (20d) would represent a period of 640ms. The total range is from 32ms to 4.06 seconds (see [Table 5.45](#)).

APPLICATION NOTE: Due to constraints on the LED Drive PWM operation, any Breathe Period less than 160ms (05h) may not be achievable. The device will breathe at the minimum period possible as determined by the period and min / max duty cycle settings.

5.31 LED Configuration Register

Table 5.48 LED Configuration Register

ADDR	R/W	REGISTER	B7	B6	B5	B4	B3	B2	B1	B0	DEFAULT
88h	R/W	LED Config	-	RAMP_ALERT	PULSE2_CNT[2:0]			PULSE1_CNT[2:0]			04h

The LED Configuration register controls general LED behavior as well as the number of pulses that are sent for the PULSE LED output behavior.

Bit 6 - RAMP_ALERT - Determines whether the device will assert the ALERT# pin when LEDs actuated by the LED Output Control register bits have finished their respective behaviors.

- '0' (default) - The ALERT# pin will not be asserted when LEDs actuated by the LED Output Control register have finished their programmed behaviors.
- '1' - The ALERT# pin will be asserted whenever any LED that is actuated by the LED Output Control register has finished its programmed behavior.

Bits 5 - 3 - PULSE2_CNT[2:0] - Determines the number of pulses used for the Pulse 2 behavior as shown in [Table 5.49](#).

Bits 2 - 0 - PULSE1_CNT[2:0] - Determines the number of pulses used for the Pulse 1 behavior as shown in [Table 5.49](#).

Table 5.49 PULSEX_CNT Decode

PULSEX_CNT[2:0]			NUMBER OF BREATHS
2	1	0	
0	0	0	1 (default - Pulse 2)
0	0	1	2
0	1	0	3
0	1	1	4
1	0	0	5 (default - Pulse 1)
1	0	1	6
1	1	0	7
1	1	1	8

5.32 LED Duty Cycle Registers

Table 5.50 LED Duty Cycle Registers

ADDR	R/W	REGISTER	B7	B6	B5	B4	B3	B2	B1	B0	DEFAULT
90h	R/W	LED Pulse 1 Duty Cycle	P1_MAX_DUTY[3:0]				P1_MIN_DUTY[3:0]				F0h
91h	R/W	LED Pulse 2 Duty Cycle	P2_MAX_DUTY[3:0]				P2_MIN_DUTY[3:0]				F0h
92h	R/W	LED Breathe Duty Cycle	BR_MAX_DUTY[3:0]				BR_MIN_DUTY[3:0]				F0h
93h	R/W	Direct Duty Cycle	DR_MAX_DUTY[3:0]				DR_MIN_DUTY[3:0]				F0h

The LED Duty Cycle registers determine the minimum and maximum duty cycle settings used for the LED for each LED behavior. These settings affect the brightness of the LED when it is fully off and fully on.

The LED driver duty cycle will ramp up from the minimum duty cycle (see [Section 5.32](#)) to the maximum duty cycle and back down again.

APPLICATION NOTE: Changes to the Duty Cycle settings will be applied immediately. When the respective register is written, the LED output will be reset to the minimum (or maximum) setting and restarted at the updated settings.

APPLICATION NOTE: Upon power on reset (or upon release of the RESET pin), the first breath will breathe from 100% (or 0% duty cycle as determined by the polarity registers) to the programmed minimum (or maximum as determined by the polarity registers) and then proceed normally.

APPLICATION NOTE: If the min duty cycle and the max duty cycle are set to the same % then the minimum duty cycle will automatically be changed to the next lower setting. For example, if the maximum duty cycle were set at 1100b (35%) and the minimum duty cycle were set at 1101b (35%), the device will automatically use the minimum value at 1100b (25%).

Bits 7 - 4 - X_MAX_DUTY[3:0] - Determines the maximum PWM duty cycle for the LED drivers as shown in [Table 5.51](#)

Bits 3 - 0 - X_MIN_DUTY[3:0] - Determines the minimum PWM duty cycle for the LED drivers as shown in [Table 5.51](#).

Table 5.51 LED Duty Cycle Decode

X_MAX/MIN_DUTY [3:0]				MAXIMUM DUTY CYCLE	MINIMUM DUTY CYCLE
3	2	1	0		
0	0	0	0	1%	0%
0	0	0	1	2%	1%
0	0	1	0	3%	2%
0	0	1	1	4%	3%
0	1	0	0	5%	4%

Table 5.51 LED Duty Cycle Decode (continued)

X_MAX/MIN_DUTY [3:0]				MAXIMUM DUTY CYCLE	MINIMUM DUTY CYCLE
3	2	1	0		
0	1	0	1	6%	5%
0	1	1	0	7%	6%
0	1	1	1	9%	7%
1	0	0	0	11%	9%
1	0	0	1	14%	11%
1	0	1	0	18%	14%
1	0	1	1	25%	18%
1	1	0	0	35%	25%
1	1	0	1	50%	35%
1	1	1	0	70%	50%
1	1	1	1	100%	70%

5.33 LED Direct Ramp Rates Register

Table 5.52 LED Direct Ramp Rates Register

ADDR	R/W	REGISTER	B7	B6	B5	B4	B3	B2	B1	B0	DEFAULT
94h	R/W	LED Direct Ramp Rates	-	-	RISE_RATE[2:0]			FALL_RATE[2:0]			00h

The LED Direct Ramp Rates register control the rising and falling edge time of an LED that is configured to operate in Direct mode. The rising edge time corresponds to the amount of time the LED takes to transition from its minimum duty cycle to its maximum duty cycle. Conversely, the falling edge time corresponds to the amount of time that the LED takes to transition from its maximum duty cycle to its minimum duty cycle.

Bits 5 - 3 - RISE_RATE[2:0] - Determines the rising edge time of an LED when it transitions from its minimum drive state to its maximum drive state as shown in [Table 5.53](#).

Bits 2 - 0 - FALL_RATE[2:0] - Determines the falling edge time of an LED when it transitions from its maximum drive state to its minimum drive state as shown in [Table 5.53](#).

Table 5.53 Rise / Fall Rate and Off Delay Decode

RISE_RATE/ FALL_RATE / DIR_OFF_DLY [2:0]			RISE / FALL TIME (T_{RISE} / T_{FALL}), OFF DELAY (T_{OFF})
2	1	0	
0	0	0	0
0	0	1	250ms
0	1	0	500ms

Table 5.53 Rise / Fall Rate and Off Delay Decode (continued)

RISE_RATE/ FALL_RATE / DIR_OFF_DLY [2:0]			RISE / FALL TIME (T_{RISE} / T_{FALL}), OFF DELAY (T_{OFF})
2	1	0	
1	1	1	750ms
1	0	0	1s
1	0	1	1.25s
1	1	0	1.5s
1	1	1	2s

5.34 LED Off Delay Register

Table 5.54 LED Off Delay Register

ADDR	R/W	REGISTER	B7	B6	B5	B4	B3	B2	B1	B0	DEFAULT
95h	R/W	LED Off Delay Register	-	-		-	-	DIR_OFF_DLY [2:0]			00h

The LED Off Delay register determines the amount of time an LED In Direct Mode remains active after it is no longer actuated (such as after a release has been detected or the drive state has been changed).

Bits 2 - 0 - DIR_OFF_DLY[2:0] - Determines the turn-off delay for all LEDs that are configured to operate in Direct Mode as shown in [Table 5.53](#).

The Direct Mode operation is determined by the combination of programmed Rise Time, Fall Time, Min and Max Duty cycles, Off Delay, and polarity. [Figure 5.5](#) shows the behavior for Non-Inverted polarity while [Figure 5.6](#) shows the behavior for inverted polarity.

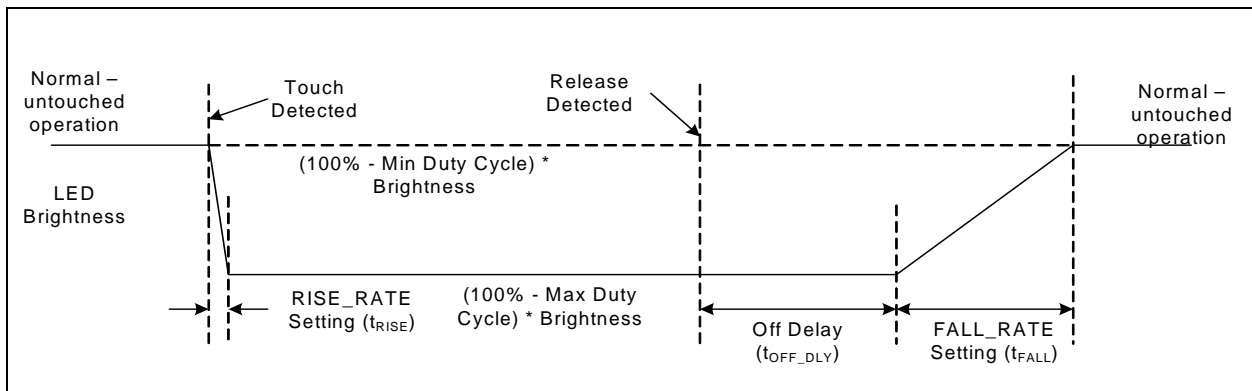

Figure 5.5 Direct Mode Behavior for Non-Inverted Polarity

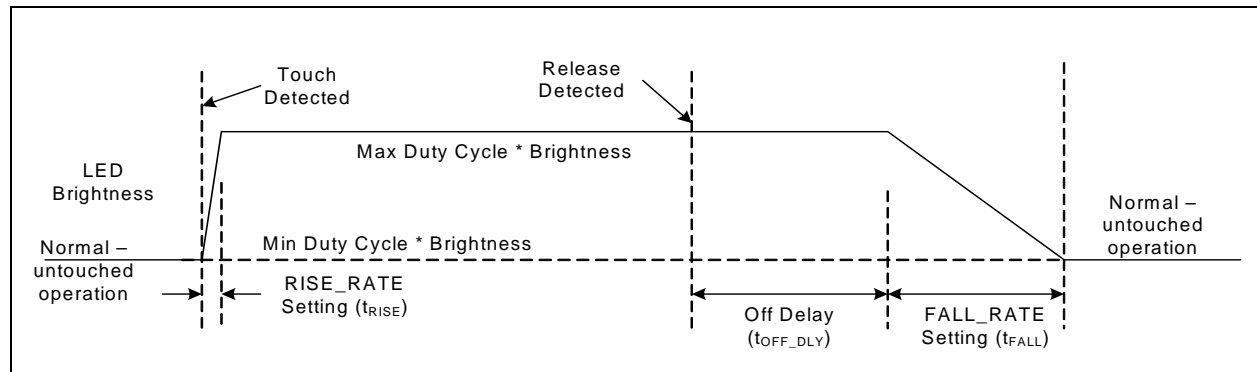

Figure 5.6 Direct Mode Behavior for Inverted Polarity

5.35 Product ID Register

Table 5.55 Product ID Register

ADDR	R/W	REGISTER	B7	B6	B5	B4	B3	B2	B1	B0	DEFAULT
FDh	R	Product ID	0	1	0	0	0	0	1	0	42h

The Product ID register stores a unique 8-bit value that identifies the device.

5.36 Manufacturer ID Register

Table 5.56 Vendor ID Register

ADDR	R/W	REGISTER	B7	B6	B5	B4	B3	B2	B1	B0	DEFAULT
FEh	R	Manufacturer ID	0	1	0	1	1	1	0	1	5Dh

The Vendor ID register stores an 8-bit value that represents SMSC.

5.37 Revision Register

Table 5.57 Revision Register

ADDR	R/W	REGISTER	B7	B6	B5	B4	B3	B2	B1	B0	DEFAULT
FFh	R	Revision	1	0	0	0	0	0	0	1	81h

The Revision register stores an 8-bit value that represents the part revision.

Chapter 6 Package Information

6.1 CAP1028 Package Drawings

Revision 1.1 (08-05-09)

66
 DATASHEET

SMSC CAP1028

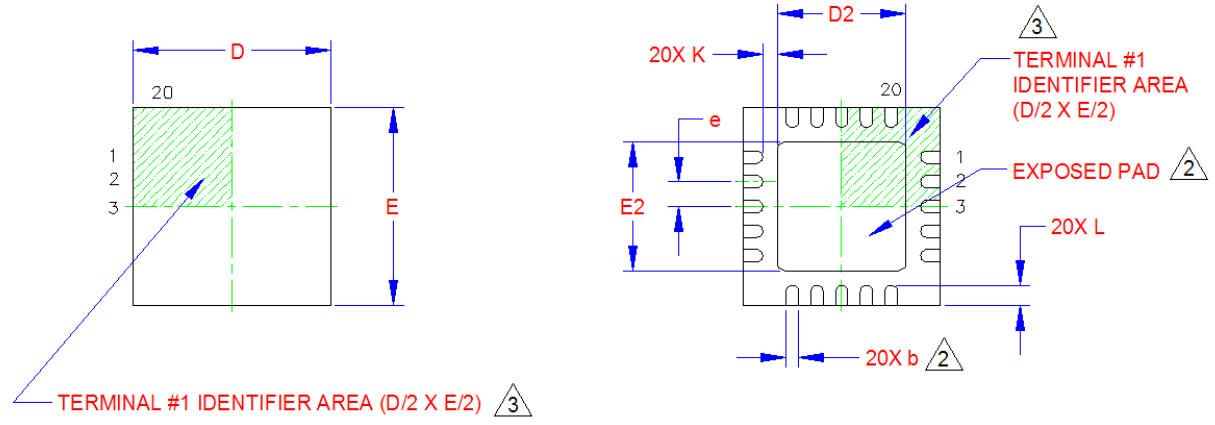

TOP VIEW

BOTTOM VIEW

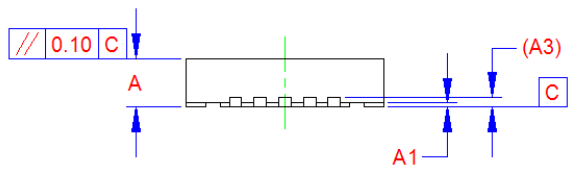

SIDE VIEW

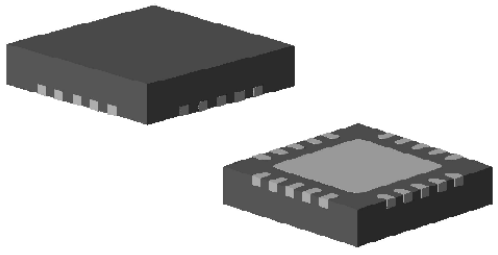

3-D VIEWS

Figure 6.1 20-Pin QFN 4mm x 4mm Package Drawing

COMMON DIMENSIONS					
SYMBOL	MIN	NOM	MAX	NOTE	REMARK
A	0.80	0.85	0.90	-	OVERALL PACKAGE HEIGHT
A1	0	0.02	0.05	-	STANDOFF
A3	0.20 REF			-	LEAD-FRAME THICKNESS
D/E	3.90	4.00	4.10	-	X/Y BODY SIZE
D2/E2	2.50	2.60	2.70	2	X/Y EXPOSED PAD SIZE
L	0.35	0.40	0.45	-	TERMINAL LENGTH
b	0.18	0.25	0.30	2	TERMINAL WIDTH
K	0.20	-	-	-	TERMINAL TO PAD DISTANCE
e	0.50 BSC			-	TERMINAL PITCH

NOTES:

1. ALL DIMENSIONS ARE IN MILLIMETERS.
2. POSITION TOLERANCE OF EACH TERMINAL AND EXPOSED PAD IS $\pm 0.05\text{mm}$ AT MAXIMUM MATERIAL CONDITION. DIMENSIONS "b" APPLIES TO PLATED TERMINALS AND IT IS MEASURED BETWEEN 0.15 AND 0.30 mm FROM THE TERMINAL TIP.
3. DETAILS OF TERMINAL #1 IDENTIFIER ARE OPTIONAL BUT MUST BE LOCATED WITHIN THE AREA INDICATED.

Figure 6.2 20-Pin QFN 4mm x 4mm Package Dimensions

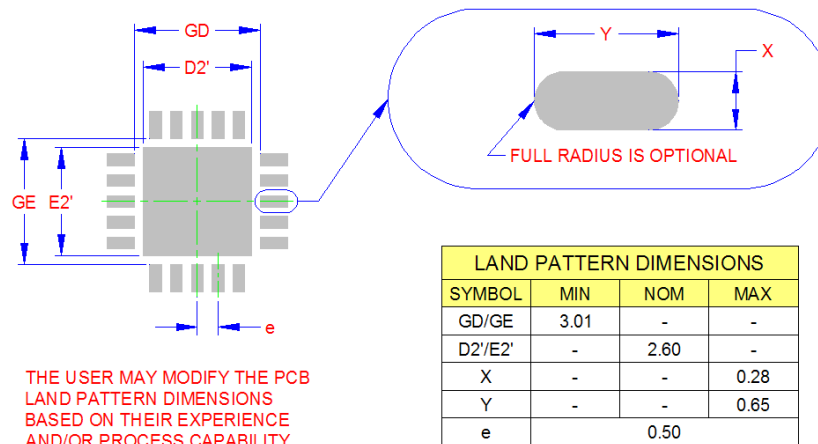

RECOMMENDED PCB LAND PATTERN

Figure 6.3 20-Pin QFN 4mm x 4mm PCB Drawing

6.2 Package Marking

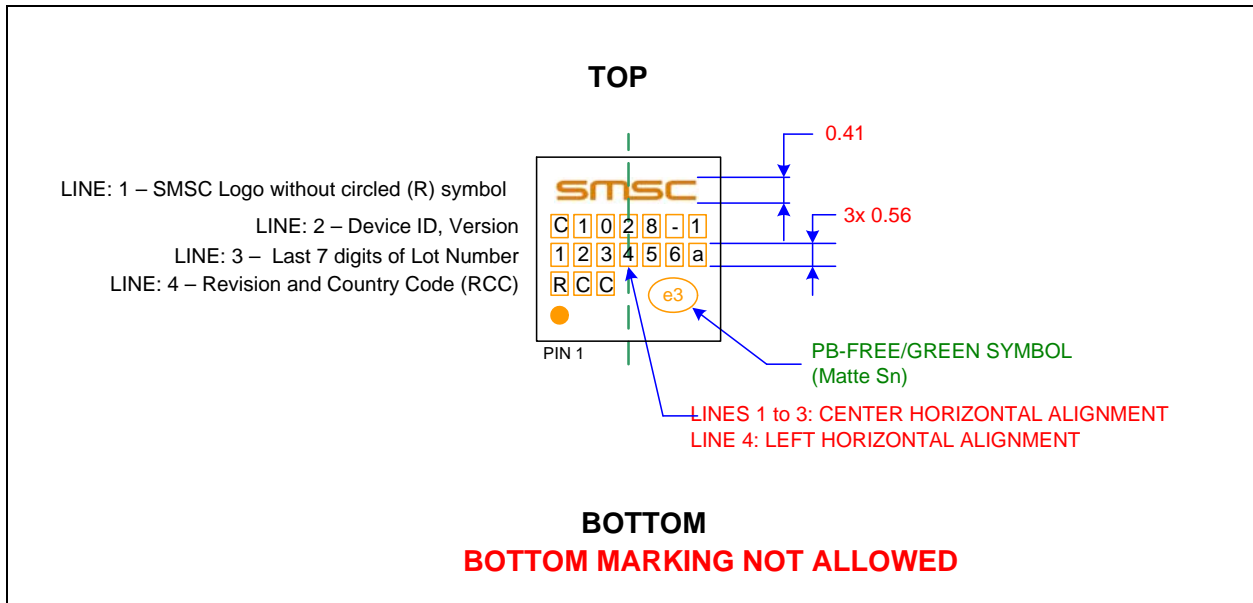

Figure 6.4 CAP1028 Package Markings

Table 7.1 Customer Revision History (continued)

REVISION LEVEL & DATE	SECTION/FIGURE/ENTRY	CORRECTION
	Section 6.2, "Package Marking"	Updated package markings per new standards
Rev. 1.0 (06-16-09)	Document title modified; reel size added to ordering information; updates to pinout, general description and register set.	
	Chapter 1, Pin Description	Pin tables modified adding SPI to "ALERT# / BC_IRQ#" pin Updated pin description for WAKE/SPI_MOSI pin to identify that it can be an input during Deep Sleep.
	Table 2.1, "Absolute Maximum Ratings"	Table and notes following table modified
	Section 3.1, "Communications"	Updated paragraph to describe proper ADDR_COMM pin function
	Table 3.1, "ADDR_COMM Pin Decode"	"I2C" added "SMBus" in "Protocol Used" column
	Figure 3.1, "SPI Timing"	Updated figure
	Section 3.7, "BC-Link Interface"	Removed "8051" from 2nd paragraph
	Chapter 4, General Description	Second to last paragraph removed, not needed as clarification follows
	Section 4.1, "Power States"	Removed mention of LED driver outputs
	Figure 4.1, "System Diagram for CAP1028"	Updated system diagram for proper ADDR_COMM pin usage. Changed from pull-up to VDD to pull-down to GND
	Section 4.2, "RESET Pin"	Modified to indicate all communication buses
	Section 4.3, "WAKE/SPI_MOSI Pin Operation"	Updated text for wake pin during Deep Sleep
	Section 4.4, "LED Drivers"	"Pulse 1" modified
	Section 4.4, "LED Drivers"	Updated text for # of LEDs
	Table 5.1, "Register Set in Hexadecimal Order"	Updated text and register descriptions for incorrect #'s Cap Sense channels
Rev. 0.56 (5/1/09)	General	Fixed typos and updated text as necessary. Cleaned up system diagrams
	Figure 4.1, "System Diagram for CAP1028"	Updated figures for pin names
	Section 5.5, "Sensitivity Control Register"	Renamed bit fields
	Section 5.6, "Configuration Register"	Renamed bits 5 and 6

Datasheet

Table 7.1 Customer Revision History (continued)

REVISION LEVEL & DATE	SECTION/FIGURE/ENTRY	CORRECTION
Rev. 0.53 (4/23/09)	Section 3.4, "SPI Interface"	Updated section to describe Normal operation
Rev. 0.52 (4/17/09)	General	Initial document creation