

64 bit Read Only ISO15693 Standard Compliant Contactless Identification Device

General Description

The EM4033 is a 64 bit Read Only CMOS integrated circuit intended for use in passive long-range applications. The IC is full compliant with the ISO/IEC15693 and ISO18000-3 standards.

Each device contains a 64 bit unique serial number, programmed during the production, which guarantees the uniqueness of each device.

The read only memory offers 200 years data retention, tailored feature for long life-term asset applications such as archives and libraries.

The chip's low current consumption offers many essential benefits such as long reading ranges and makes it a robust and reliable solution in harsh environments.

The EM4033 integrates an optimized command set thus supporting all mandatory, an optional and one custom command.

The ISO15693 anticollision algorithm allows several tags to be simultaneously in operation within the field. The Advanced Quiet storage feature, implemented in the chip, speeds up the inventory processes, increasing in a meaningful way the item detection speed.

Applications

- Laundry
- Long-term asset management
- Archives and collections
- Libraries
- Access Control and Ticketing

IC Block Diagram

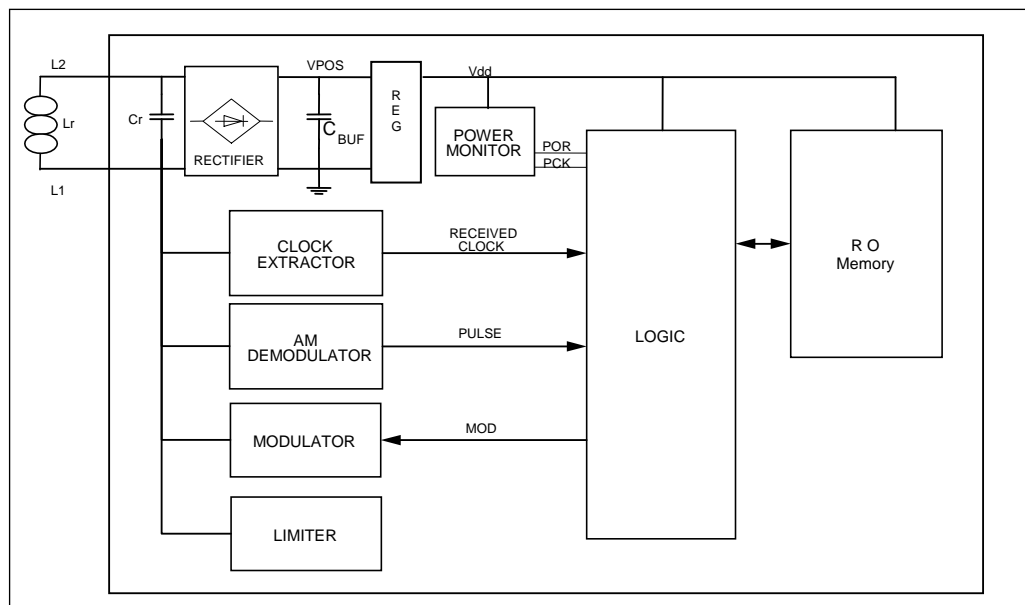

Fig. 2

Features

- Supports ISO15693 / ISO18000-3 standards
- Operating Frequency: 13.56MHz \pm 7kHz (ISM, world-wide licence free available)
- 200 years data retention
- Long read range IC offering high and reliable performances
- ISO/IEC 15693 anticollision algorithm allowing several tags within the reader field at the same time
- 64-bit Unique Identifier (UID)
- Quiet Storage feature to speed up inventory processes
- On-chip resonant capacitor: 23.5pF
- No external supply buffer capacitor needed
- 40 to +85°C temperature range
- Bonding pads optimised for flip-chip assembly

Typical Operating Configuration

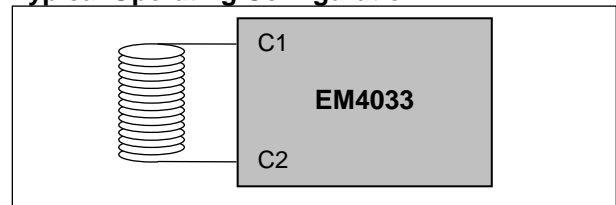

Fig. 1