

# CL-150 シリーズ

Mono-Color Upward-Lighting Type **CL-150 Series**

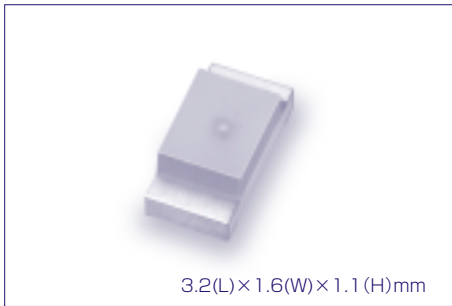

3.2(L)×1.6(W)×1.1(H)mm

● 標準サイズのチップLEDです。

● Standard size chip LED

発光色のラインアップにつきましては、発注時にお問い合わせの上、ご確認ください。

Please contact us at the time of order for the lineup of luminescent colors.

## ●絶対最大定格/Absolute Maximum Rating

(Ta 25°C)

Product code	Pd (mW)	I <sub>F</sub> (mA)	I <sub>FP</sub> (mA)	V <sub>R</sub> (V)	Top (°C)	Tst (°C)
CL-150 (UR,HRを除く) Except UR and HR	65	25	100*1	5	-25~+80	-30~+85
CL-150UR/HR	78	30				

\*1 I<sub>FP</sub>の条件はduty 1/10、パルス巾30msecです。

\*1 Condition for I<sub>FP</sub> is pulse of 1/10 duty and 30msec width.

## ●電気的光学的特性/Electro-optical Characteristics

(Ta 25°C)

Product code	Lighting color	I <sub>F</sub> (mA)	V <sub>F</sub>		λ <sub>p</sub> typ (nm)	Δλ typ (nm)	I <sub>v</sub> **		
			typ (V)	max (V)			I <sub>F</sub> (mA)	min (mcd)	typ (mcd)
CL-150R	Red	20	2.2	2.6	700	100	20	0.5	1.3
CL-150D	Orange	20	2.2	2.6	605	40	20	2.4	7.1
CL-150Y	Yellow	20	2.1	2.6	589	40	20	2.6	6.4
CL-150YG	Yellow green	20	2.2	2.6	570	30	20	5	18
CL-150G	Green	20	2.2	2.6	567	26	20	2.5	10
CL-150FG	Fresh green	20	2.2	2.6	560	26	20	2.2	6.5
CL-150PG	Pure green	20	2.2	2.6	557	24	20	1	3
CL-150SR	Super brightness red	20	2	2.6	650	40	20	1.5	4.3
CL-150SD	Super brightness orange	20	2	2.6	630	40	20	2	6.2
CL-150UR	Ultra brightness red	20	1.8	2.6	660	20	20	3.5	13
CL-150HR	High brightness red	20	1.8	2.6	660	20	20	5	23

\*NIST規格に準拠

\*Per NIST standards

## ●外形寸法図/Outline drawing

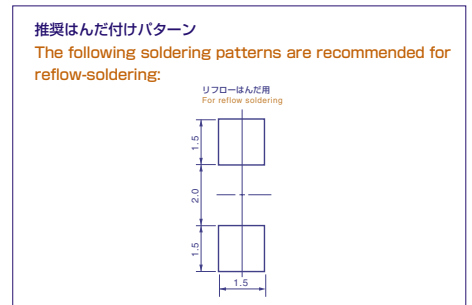
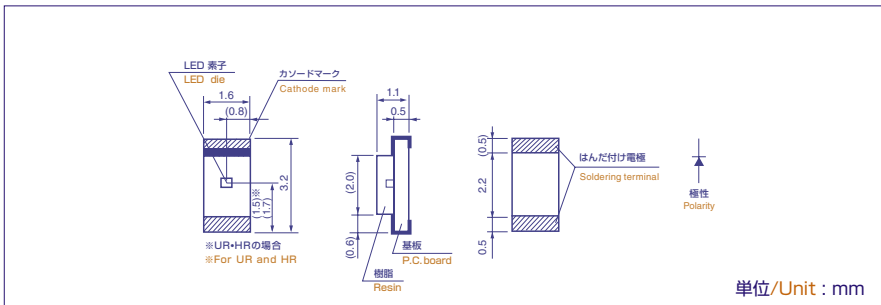

## ■ 諸特性 / Characteristics

