



LBN07080 SAW Filter Electrical Characteristic

Specifications

Parameter	Unit	Minimum	Typical	Maximum
Center Frequency	MHz	69.92	70	70.08
Insertion Loss	dB	-	30.5	32.5
1 dB Bandwidth	MHz	-	14.68	-
3 dB Bandwidth	MHz	15.2	15.25	-
40 dB Bandwidth	MHz	-	15.97	16.0
50 dB Bandwidth	MHz	-	16.05	-
Passband Variation	dB	-	1.0	1.5
Absolute Delay	usec	-	3.89	4.0
Ultimate Rejection	dB	45	50	-
Substrate Material		YZ LiNbO3		
Ambient Temperature	°C	25		
Package Size		DIP3512 (35x12.7x5.2mm ³)		

Typical Performance

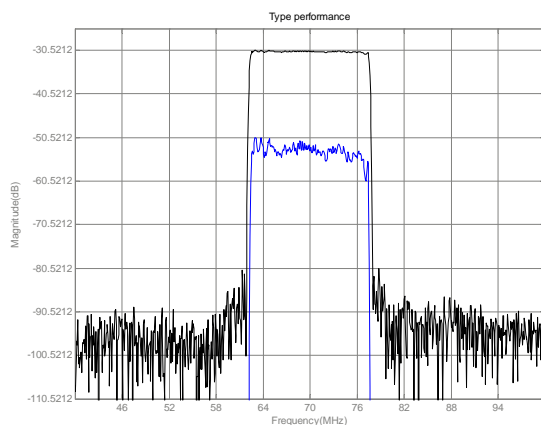

Package Outline

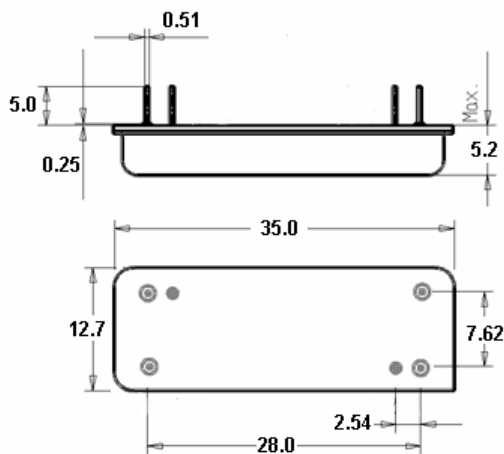

Matching Configuration

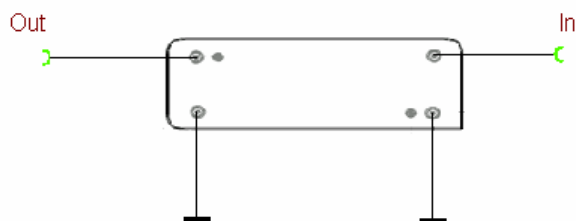

Source/Load Impedance=50 ohm

Notes - Component values may change depending on board layout.