

Innovair™

2-Wire Low-Profile Duct Smoke Detector

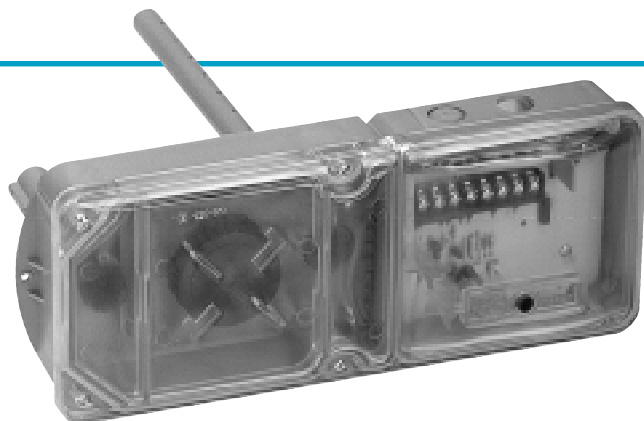

A Division of Pittway
3825 Ohio Avenue, St. Charles, IL 60174
1-800-SENSOR2 (736-7672), Fax 630-377-6495
<http://www.systemsensor.com>



Models Available

- DH100I 2-wire Ionization Detector**
- DH100P 2-wire Photoelectric Detector**

Features

- Outside mounting tabs
- Telescoping sampling tube*
- Built-in reset button
- Easy to clean
- 12/24 VDC operation
- Ion or photo models available
- Remote test station option
- Air velocity rating from 500 to 4000 FPM
- Remote annunciator option
- Easy and quick mounting to round or rectangular ducts from 1'-12' wide
- Textured cover for convenient visual inspection
- UL 268A listed
- 3-year warranty

System Sensor DH100 2-wire duct smoke detector is available as either an ionization or photoelectric model. This new design allows for simplified cleaning and

Specifications

| | |
|------------------------------|--|
| Length: | 14 ³ / ₈ inches (37 cm.) |
| Width: | 5 ¹ / ₂ inches (14 cm.) |
| Depth: | 2 ³ / ₄ inches (7 cm.) |
| Shipping Weight: | 3.75 lbs. (1.7 kg.) |
| Operating Temperature Range: | 23° to 131° F (-5° to 55° C) |

maintenance, or a change in application without removing the duct housing. The DH100 samples air currents passing through a duct and gives dependable performance for management of fans, blowers, and air conditioning systems, preventing the spread of toxic smoke and fire gases through the protected area.

WARNING: Duct smoke detectors have specific limitations. **DUCT DETECTORS ARE:**

NOT a substitute for an open area smoke detector, **NOT** a substitute for early warning detection, and **NOT** a replacement for a building's regular fire detection system.

Refer to NFPA 72 and 90A for additional duct detector application information.

| | |
|---------------------------|------------------------------|
| Operating Humidity Range: | 10% to 93% relative humidity |
| Air Duct Velocity: | 500 to 4000 ft./min. |

*Patent pending

Architectural/Engineering Specifications

The air duct smoke detector shall be a System Sensor Model DH100 Series Duct Smoke Detector. The detector housing shall be UL listed per UL 268A specifically for use in air handling systems. The detector shall operate at air velocities of 500 feet per minute to 4000 feet per minute. It shall be capable of local testing via magnetic switch or remote testing using the RTS451KEY Remote Test Station. The unit shall be reset by local reset button or RTS451KEY. The duct detector housing shall incorporate an airtight smoke chamber in compliance with UL 268A, Standard for Smoke Detectors for Duct Applications. The housing shall be capable of mounting to either rectangular or round

ducts without adapter brackets. An integral filter system shall be included to reduce dust and residue effects on detector and housing, thereby reducing maintenance and servicing. Sampling tubes shall either be telescoping or be easily installed after the housing is mounted to the duct by passing through the duct housing. The enclosure shall meet all applicable NEC and NFPA standards regarding electrical junction boxes. Terminal connections shall be of the strip and clamp method suitable for 12-18 AWG wiring.

Electrical Ratings – DH100 (Includes Detector)

| | |
|-----------------------|--|
| System Voltage: | 12/24 VDC |
| Ripple Voltage: | 4 Volts peak to peak |
| Start-up Capacitance: | 0.02 μ F maximum |
| Standby Ratings: | 8.5 VDC minimum 35 VDC maximum 120 μ A maximum |
| Alarm Ratings: | 4.2 VDC minimum at 10mA 6.6 VDC maximum at 100mA Alarm current must be limited to 100mA or less by the control panel. If used, the RA400Z remote lamp operates within the specified alarm currents. |
| Reset Voltage: | 2.50 VDC minimum |
| Reset Time: | 0.3 Sec. maximum |
| Start-up Time: | 34.0 Sec. maximum |

DH100 Wiring Guide

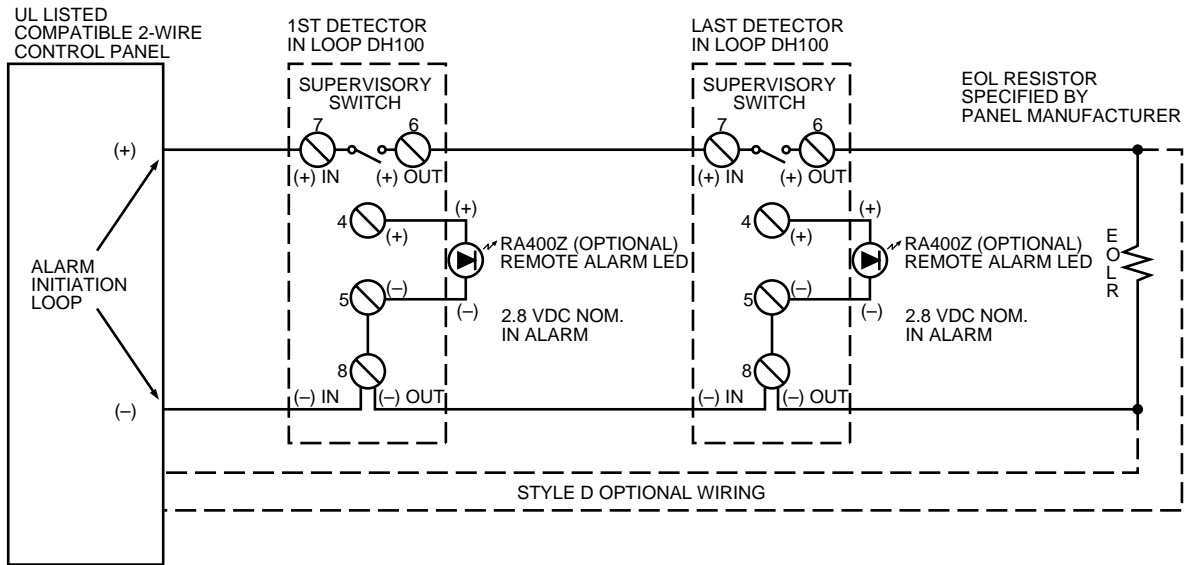

System wiring diagram for 2-wire duct detectors (detectors powered from initiating circuit)

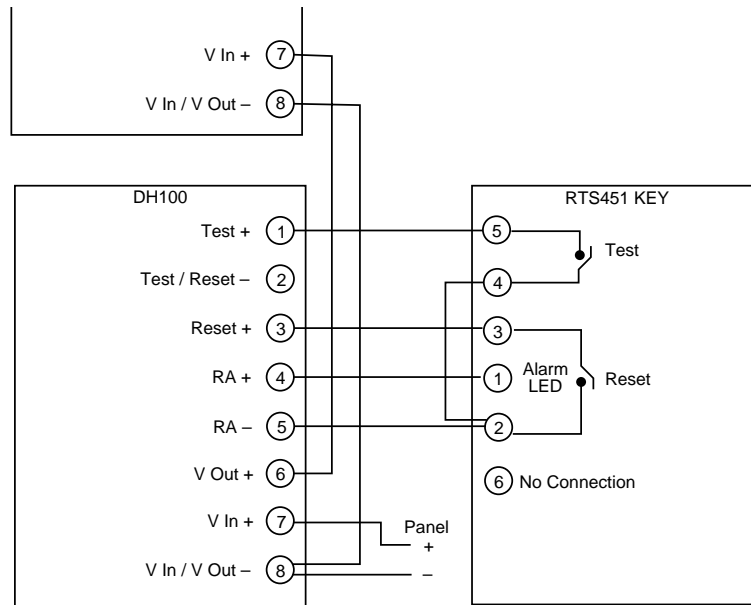

Wiring diagram for RTS451/RTS451KEY Remote Test Station to 2-wire duct detectors

Ordering Information

| Part No. | Description | Part No. | Description |
|--------------------|--|--------------|---|
| DH100I | 2-wire ionization duct detector | RTS451KEY | Remote test station with key lock |
| DH100P | 2-wire photoelectronic duct detector | RTS451 | Remote test station |
| A5052-00 | Replacement ionization sensor board | RA400Z | Remote annunciator alarm LED |
| A5069-00 | Replacement photoelectronic sensor board | APA451 | Remote annunciator with piezo alarm |
| A5061-00 | 2-wire power board | MOD400R | Sensitivity test module |
| Accessories | | F36-09-00 | Replacement air filters (two per package) |
| ST-1.5 | Metal sampling tube duct widths 1'-2' | M02-04-00 | Test magnet |
| ST-3 | Metal sampling tube duct widths 2'-4' | P48-21-00 | End cap for metal sampling tubes |
| ST-5 | Metal sampling tube duct widths 4'-8' | S08-39-01 | Photo replacement screen |
| ST-10 | Metal sampling tube duct widths 8'-12' | PA400B | Mini-Alert sounder |
| T80-71-00 | Telescoping sampling tube | PS24LOB | Mini-Alert add-on strobe |
| P48-55-00 | End cap for T80-71-00 | PS12/24LENSC | Ceiling-mount "SMOKE" lens |
| | | PS12/24LENSW | Wall-mount "SMOKE" lens |

Accessories

System Sensor provides system flexibility with a variety of accessories, including two remote test stations, and several different means of visible and audible system annunciation. As with our duct detectors, all duct detector accessories are UL listed.

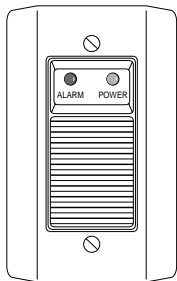

APA451
Piezo
Annunciator
(UL S4011)

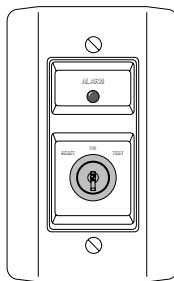

RTS451KEY
Remote Test
Station with Key
(UL S2522)

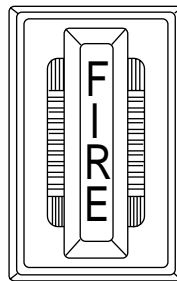

PA400 with
PS24LOW Add-on Strobe
(PS12/24LENSW
smoke lens option available)
(UL S3593)

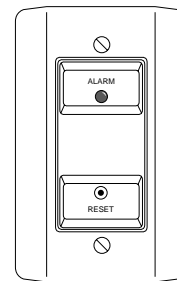

RTS451
Remote Test
Station
(UL S2522)

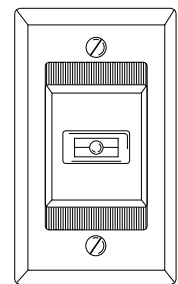

RA400Z
Remote
Annunciator
(UL S2522)

System Sensor Worldwide Manufacturing & Distribution

In Canada:

Telephone: 905-812-0767
Fax: 905-812-0771

In the Far East:

Telephone: 852-2191-9003
Fax: 852-2736-6580

In Italy:

Telephone: 39-40-9490-111
Fax: 39-40-382137

In the United Kingdom:

Telephone: 44-1403-276500
Fax: 44-1403-276501

In China:

Telephone: 852-2191-9003
Fax: 852-2736-6580

In India:

Telefax: 91-022-8202564

In Singapore:

Telephone: 65-273-2230
Fax: 65-273-2610