

## 16mm Diameter, Single-Turn, Cermet Industrial Panel Controls



### Features

- 16mm diameter, single-turn industrial panel controls
- Cermet film element
- Single unit, single shaft
- Excellent environmental characteristics
- Wide temperature range of  $-55^{\circ}\text{C}$  to  $+125^{\circ}\text{C}$
- Metal shaft and bushing
- Linear taper
- Shaft lock available
- Panel and PCB mounting styles
- Lug or right angle mount pin terminals
- 3.2mm diameter shafts in slot, flat or round end styles
- Standard 10mm or 15mm shaft length

### Specifications

#### Electrical

<b>Standard Resistance Range</b>	100Ω to 1MΩ
<b>Resistance Tolerance</b>	±20% standard (±10% special order)
<b>End Resistance</b>	3Ω max.
<b>Resistance Taper</b>	B = linear
<b>Peak Noise (C.R.V.)</b>	3% or 5Ω, whichever is greater
<b>Power Rating</b>	0.5 watt at $+70^{\circ}\text{C}$ , 0 watt at $+120^{\circ}\text{C}$
<b>Maximum Input Voltage</b>	400VDC or power rating, whichever is smaller
<b>Temperature Coefficient</b>	±100 ppm/ $^{\circ}\text{C}$ , 200Ω to 500kΩ ±250 ppm/ $^{\circ}\text{C}$ , other values
<b>Insulation Resistance</b>	500MΩ minimum at 500VDC
<b>Dielectric Strength</b>	500VAC, 1 minute

#### Mechanical

<b>Mechanical Travel</b>	$260^{\circ} \pm 10^{\circ}$
<b>Shaft Torque</b>	20 to 200 gf·cm (0.277 to 2.773 oz·in)
<b>Stop Strength</b>	3 kgf·cm (41.59 oz·in) max.
<b>Mounting Nut Torque</b>	10.2 kgf·cm (141.4 oz·in) max.
<b>Solderability</b>	$235^{\circ}\text{C}$ , 5 seconds
<b>Marking</b>	Model type, taper, resistance, shaft type, terminal identification, date code

#### Environmental

<b>Temperature Range</b>	$-55^{\circ}\text{C}$ to $+125^{\circ}\text{C}$
<b>High Temperature Exposure</b>	$+120^{\circ}\text{C}$ , 250 hours $\Delta\text{T/R} \leq \pm 4\%$
<b>Load Life</b>	$+70^{\circ}\text{C}$ , 1,000 hours with rated load $\Delta\text{T/R} \leq \pm 5\%$
<b>Thermal Shock</b>	$-55^{\circ}\text{C} \sim +120^{\circ}\text{C}$ , 5 cycles without load $\Delta\text{T/R} \leq \pm 3\%$
<b>Vibration</b>	10-55Hz, 1.5mm amplitude, 3 directions, 2 hours each $\Delta\text{T/R} \leq \pm 2\%$
<b>Soldering Heat Resistance</b>	$350^{\circ}\text{C}$ , 3 seconds $\Delta\text{T/R} \leq \pm 1\%$
<b>Rotational Life</b>	15,000 cycles (500 cycles for shaft lock models only) without load $\Delta\text{T/R} \leq \pm 4\%$

$\Delta\text{T/R}$  = Total Resistance Change

**GF16**  
**Panel Mount, Single Unit, Single Shaft**  
**Right Angle Ear-Lug Terminals, 3-Lug Inline Pattern**

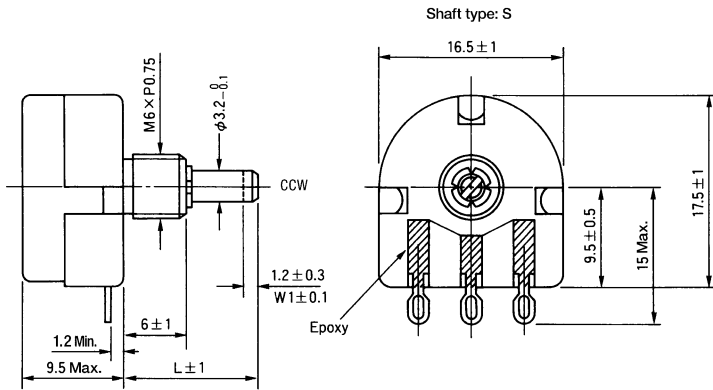

**Recommended Panel Mounting Hole**

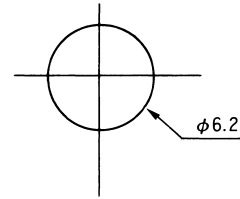

**GF16L**  
**Panel Mount, Single Unit, Single Shaft with Shaft Lock**  
**Right Angle Ear-Lug Terminals, 3-Lug Inline Pattern**

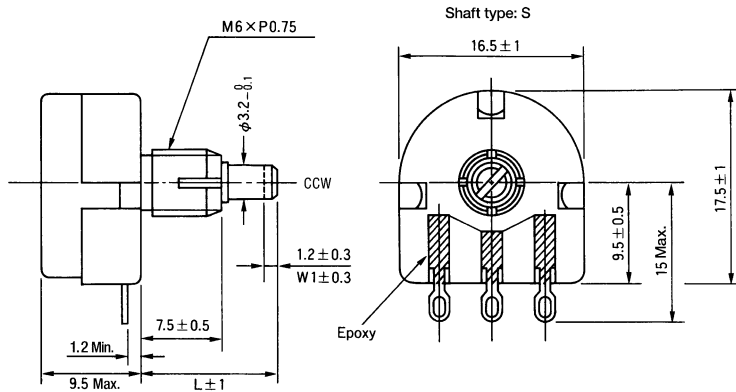

**Recommended Panel Mounting Hole**

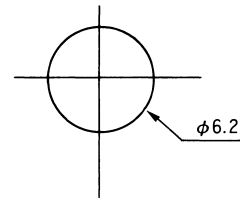

**GF16**  
**PCB Mount, Single Unit, Single Shaft**  
**Right Angle Mount Pin Terminals, 3-Pin Inline Pattern, 2-Pin Rear Support Bracket**

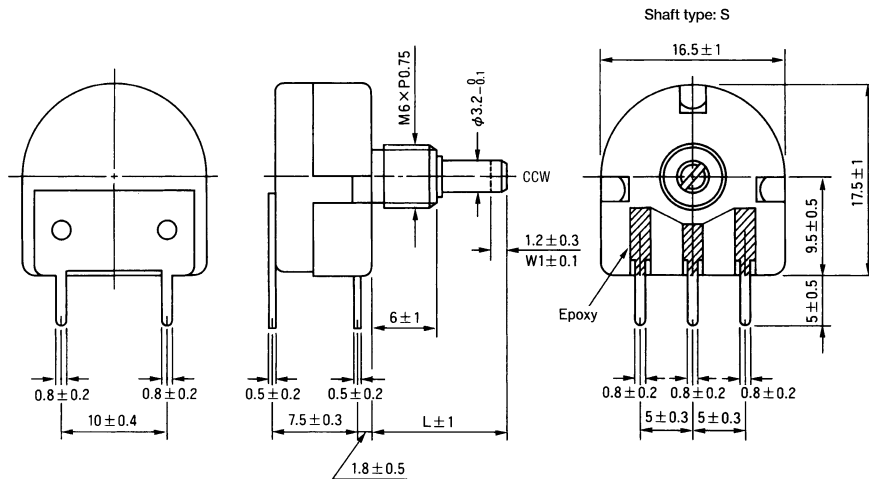

**Recommended PCB Mounting Holes**

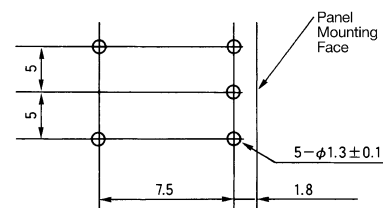

**GF16L**

**PCB Mount, Single Unit, Single Shaft with Shaft Lock**

**Right Angle Mount Pin Terminals, 3-Pin Inline Pattern, 2-Pin Rear Support Bracket**

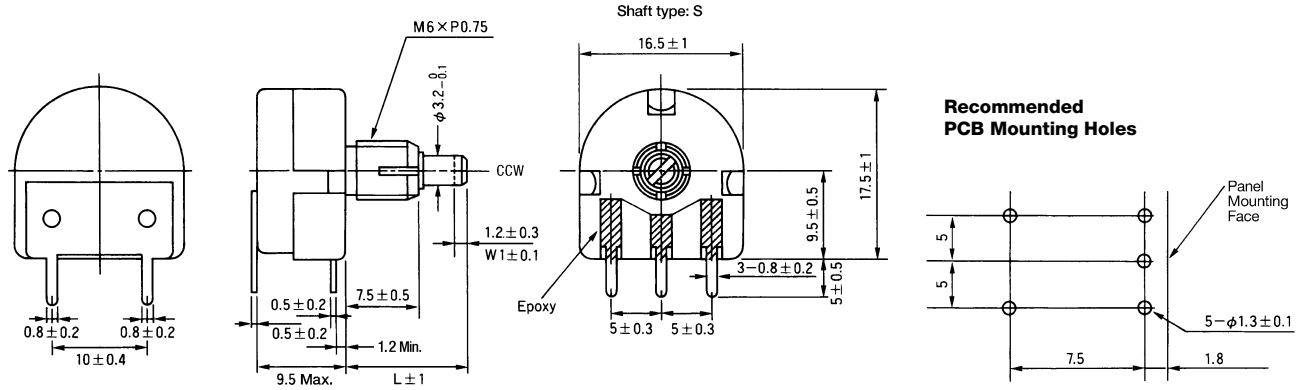

**GF P 16 L 10 S B 103 M**

NOTE: FMS = From Mounting Surface

- ➔ **Resistance Tolerance:** **M** = ±20% (standard).  
**K** = ±10% (special order).
- ➔ **Resistance Code:** Expressed in ohms. A three digit code where the first two digits are significant figures, and the third digit indicates the number of zeros that follow these figures (i.e., 100 = 10Ω; 101 = 100Ω; 102 = 1,000Ω; 103 = 10,000Ω; 105 = 1,000,000Ω). See table for standard resistance values.
- ➔ **Resistance Taper:** **B** = Linear.
- ➔ **Shaft End Style:** **S** = Slotted.  
**F** = Flatted.  
**R** = Round.
- ➔ **Standard Shaft Length:** **10** = 10mm FMS.  
**15** = 15mm FMS.  
Up to 30mm shaft length available (special order).
- ➔ **Shaft Lock:** **L** = With Shaft Lock.  
**Blank** = Without Shaft Lock.
- ➔ **Size:** **16** = 16mm Diameter.
- ➔ **Style:** **Blank** = Panel Mount, Single Unit, Single Shaft, Right Angle Ear-Lug Terminals, 3-Lug Inline Pattern.  
**P** = PCB Mount, Single Unit, Single Shaft, Right Angle Mount Pin Terminals, 3-Pin Inline Pattern, 2-Pin Rear Support Bracket.
- ➔ **TOCOS Series Name:** **GF** = Cermet Film Element.

Standard Resistance Values and Part Numbering Codes

Standard Nominal Total Resistance Values and Part Numbering Codes

Resistance (Ω)	Code	Resistance (Ω)	Code	Resistance (Ω)	Code	Resistance (Ω)	Code	Resistance (Ω)	Code
100	101	1,000	102	10,000	103	100,000	104	1,000,000	105
200	201	2,000	202	20,000	203	200,000	204		
500	501	5,000	502	50,000	503	500,000	504		

Refer to Shaft End Styles Specifications and Hardware Specifications for details and availability.  
For additional information, refer to Guidelines and Precautions for Using Panel Controls.