

Three Termination Capacitor/Resistor EMI Filter for Signal Lines

ISO 9001:2000
TS-16949

Type KCR

1. Features

- The KCR Series provides improved reduction of radiated noise and drives it into the ground.
- Capacitor/Resistor filter

2. Applications

- Noise reduction in a variety of circuits

3. Ordering & Specifying Information

Type designation shall be as the following form.

KCR	1206	T	TE	220/500
Type	Size	Termination Material	Packaging	Capacitance/Resistance
	1206	T: Sn	TE: 7" Embossed Taping 2,000 pcs/reel	2 Significant digits + No. of zeros

4. Dimension and Structure

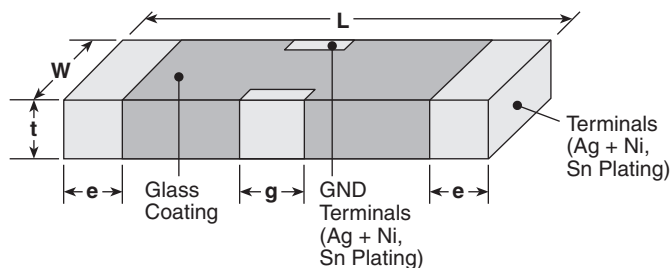

Size	L	W	t	g	e
1206	.126±.008 (3.2±0.2)	.063±.008 (1.6±0.2)	.031±.008 (0.8±0.2)*	.039±.012 (1.0±0.3)	.016±.012 (0.4±0.3)

* KCR1206T221/500: t = .043 ± .008 (1.1 ± 0.2)
KCR1206T221/101: t = .043 ± .008 (1.1 ± 0.2)

4.1 Circuit

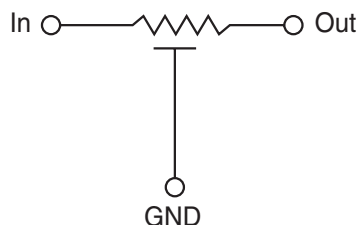

5. Ratings

Ordering Code	Capacitance (pF)	Capacitance Tolerance	Resistance (Ω)	Resistance Tolerance (%)	Power Rating (W)	Temp. Range (°C)
KCR1206T220/500	22	+50 ~ -20	50	±30	1/16	-40 ~ +85
KCR1206T220/101	22		100			
KCR1206T470/500	47		50			
KCR1206T470/101	47		100			
KCR1206T101/500	100		50			
KCR1206T101/101	100		100			
KCR1206T221/500	220		50			
KCR1206T221/101	220		100			

Customized parts are available upon request.

5.1 Rating

Item	Specification
Operating temperature range	-40°C ~ +85°C
Storage temperature range	-40°C ~ +85°C (After soldering)
Measuring condition (Standard)	
Temperature	15 ~ 35°C
Relative humidity	20 ~ 90%
Measuring condition (Precision)	
Temperature	20°C ±1°C
Relative humidity	60 ~ 67%

6. Characteristics

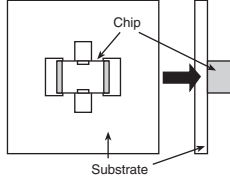
Item	Requirement	Conditions															
Insulation Resistance	Min 1000M ohms	Applied rated voltage for 60 seconds.															
Capacitance	Within the tolerance	Frequency: 1kHz Voltage: 1Vrms															
DC Resistance	Within the tolerance	DC: 0.3V Max.															
Terminal Adhesion Strength	No physical damage	Solder a chip to a test substrate and then laterally apply a load (5N, 500gF) in the arrow direction. 															
Soldering Heat Resistance	Appearance: No physical damage Capacitance: Within tolerance Dielectric Loss: Within tolerance Insulation Resistance: Within tolerance	Flux: 25% rosin Pre-heating: 60 sec Pre-heating Temp: 150°C Solder: H60A Solder Temp: 260°C ±5°C Dip Time: 5 ±0.5 sec															
Solderability	More than 95% of the terminal electrode shall be covered with new solder.	Flux: 25% rosin Pre-heating: 60 sec Pre-heating Temp: 150°C Solder: H60A Solder Temp: 230°C ±5°C Dip Time: 4 ±1 sec															
Temperature Cycle	Appearance: No physical damage Capacitance: Within tolerance Dielectric Loss: Within tolerance Insulation Resistance: Within tolerance	Repeat the following heat cycle 10 times: <table border="1"> <thead> <tr> <th>Step</th> <th>Temperature</th> <th>Time</th> </tr> </thead> <tbody> <tr> <td>1</td> <td>-40°C ±3°C</td> <td>30 min ±3 min</td> </tr> <tr> <td>2</td> <td>Room Temp.</td> <td>15 min max.</td> </tr> <tr> <td>3</td> <td>85°C ±2°C</td> <td>30 min ±3 min</td> </tr> <tr> <td>4</td> <td>Room Temp.</td> <td>15 min max.</td> </tr> </tbody> </table>	Step	Temperature	Time	1	-40°C ±3°C	30 min ±3 min	2	Room Temp.	15 min max.	3	85°C ±2°C	30 min ±3 min	4	Room Temp.	15 min max.
Step	Temperature	Time															
1	-40°C ±3°C	30 min ±3 min															
2	Room Temp.	15 min max.															
3	85°C ±2°C	30 min ±3 min															
4	Room Temp.	15 min max.															
High Temperature Resistance	Appearance: No physical damage Capacitance: Within tolerance Dielectric Loss: Within tolerance Insulation Resistance: Within tolerance	Temp: 70°C ±2°C Bias: 150% of rated voltage Test Time: 1000+48/-0 hour															
Humidity Resistance (unload)	Appearance: No physical damage Capacitance: Within tolerance Dielectric Loss: Within tolerance Insulation Resistance: Within tolerance	Temp: 85°C ±2°C Humidity: 85% ±5% Test Time: 500+24/-0 hour															

6. Characteristics Cont.

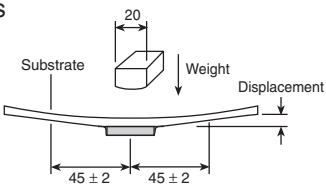
Item	Requirement	Conditions
Vending Substrate	Appearance: No physical damage Capacitance: Within tolerance	After soldering a chip to a test substrate, bend the substrate by 1 mm and then measure. The substrate is GE4 or based on GE4. 
Humidity Resistance (load)	Appearance: No physical damage Capacitance: Within tolerance Dielectric Loss: Within tolerance Insulation Resistance: Within tolerance	Temp: 40°C ±2°C Humidity: 90 - 95% Bias: 100% of rated voltage Test Time: 500+24/-0 hour
Low Temperature Resistance (unload)	Appearance: No physical damage Capacitance: Within tolerance Dielectric Loss: Within tolerance Insulation Resistance: Within tolerance	Temp: -40°C ±2°C Test Time: 1000+48/-0 hour
Vibration	Appearance: No physical damage Capacitance: Within tolerance Dielectric Loss: Within tolerance Insulation Resistance: Within tolerance	The frequency of applied vibratoin should be swept from 10 Hz to 55 Hz and return to 10 Hz. This cycle time should be about 1 min and thiscycle should be repeated. Amplitude (total Excursion): 1.5 mm This motion shall be applied for period of 2 hours in each 3 mutually perpendicular axes. (total of 6 hours)

After Temperature cycle test, High temperature resistance test, Humidity resistance test or Low temperature resistance test, the tested sample should be measured after having left in temperature from 15° to 35°C and relative humidity from 45% to 75% for 24 hours.

7. Packaging Specifications

7.1 Taping

Packaging of components on continuous tape is complete with carrier tape for putting components and cover tape for sealing.

(1) Dimensions of Carrier Tape

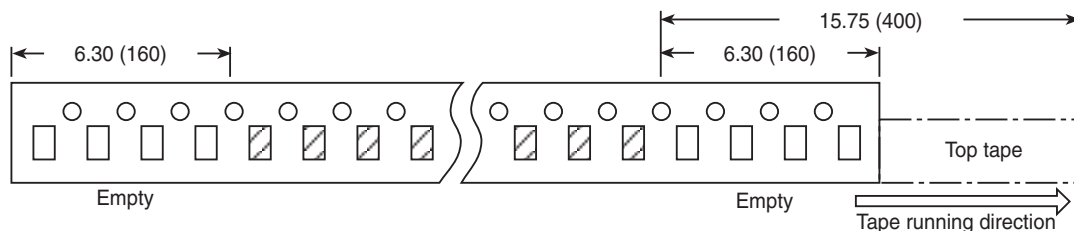

(1) Dimensions of Carrier Tape Cont.

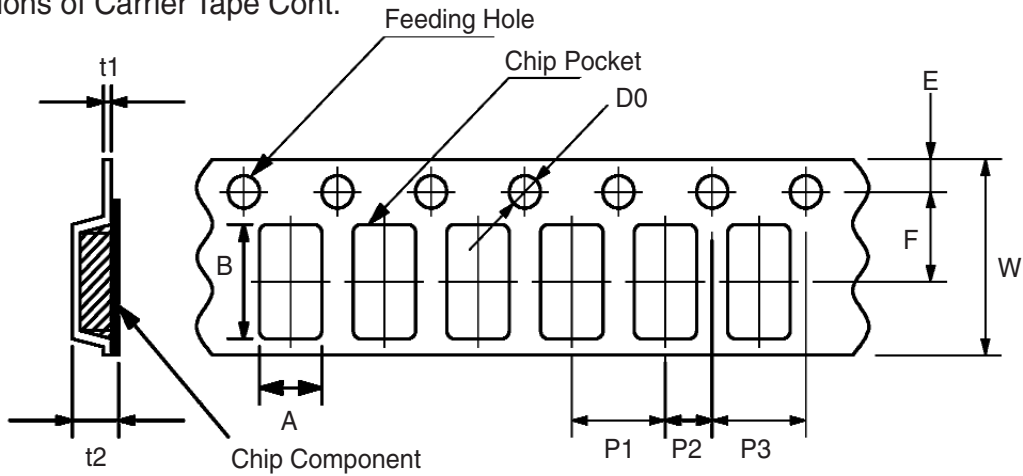

Dimensions in inches (mm)

Series	A	B	W	F	E	P1
KCR1206	0.078 ± 0.003 (2.0 ± 0.1)	0.137 ± 0.003 (3.5 ± 0.1)	0.314 ± 0.011 (8.0 ± 0.3)	0.137 ± 0.02 (3.5 ± 0.05)	0.068 ± 0.003 (1.75 ± 0.1)	0.157 ± 0.003 (4.0 ± 0.1)

Dimensions in inches (mm)

Series	P2	P3	D0	t1	t2
KCR1206	0.078 ± 0.02 (2.0 ± 0.05)	0.157 ± 0.003 (4.0 ± 0.1)	$0.059 \pm^{+0.003}_{-0}$ ($1.5 \pm^{+0.1}_{-0}$)	0.011 ± 0.001 (0.3 ± 0.05)	0.098 (2.5 max)

(2) Reel dimensions

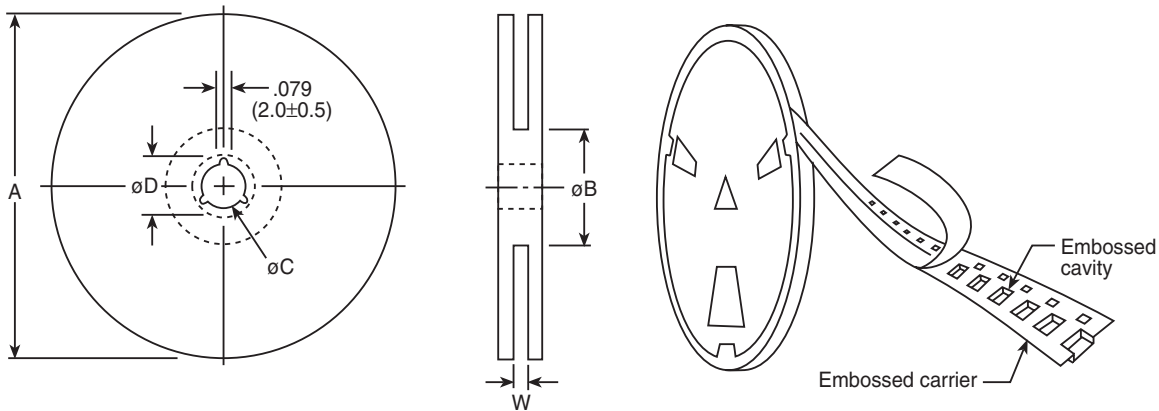

Dimensions in inches (mm)

Series	A	B	C	D	E	W (min)	W (max)
KCR1206	7.00 ± 0.78 (178 ± 2)	2.36 (60 min)	0.511 ± 0.02 (13 ± 0.5)	0.83 ± 0.03 (21 ± 0.8)	0.079 ± 0.02 (2 ± 0.5)	0.311 ± 0.059 (7.9 ± 1.5)	0.429 ± 0.059 (10.9 ± 1.5)

8. General Information

(1) Storage

The products must be stored from 10° to 35°C and from 30% to 70% RH before soldering.

(2) Soldering

In general, ceramics are very sensitive to thermal shocks. Therefore the parts shall not be exposed to a sudden temperature increase, decrease or partial heating.

Products shall be pre-heated prior to soldering. The temperature difference between the solder temperature and product temperature does not exceed 130°C.

It is desirable that the soldering temperature be kept 240° - 250°C and that soldering time be less than 4 seconds.

Flux shall be rosin type. Do not use strong acid type flux.

The tip of the soldering iron shall be 20 W or less, 3f or less, and 220° - 250° C. Recommended soldering thermal and time conditions are shown in the Recommend Soldering Conditions.

(3) Mounting

After mounting components on the printed circuit board, do not apply stress through board bending or mishandling.

(4) Pattern design

The land pattern is recommended as follows.

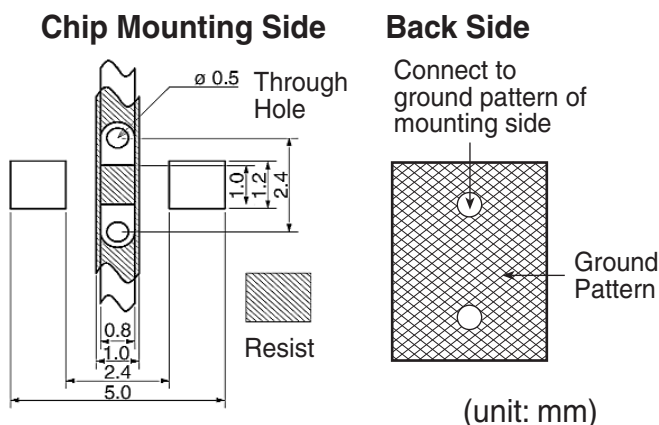

9. Recommended Soldering Conditions

Recommended Condition for Reflow Soldering

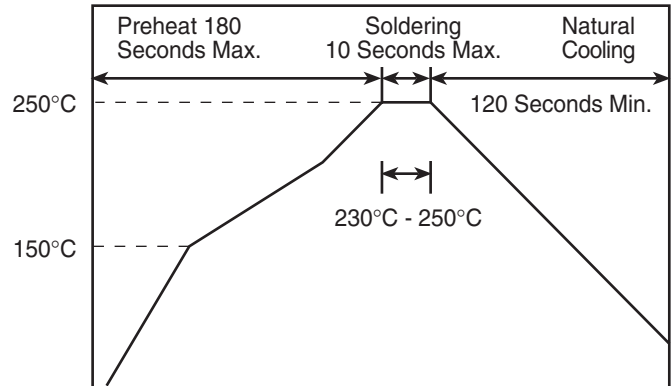

Recommended Condition for Flow Soldering

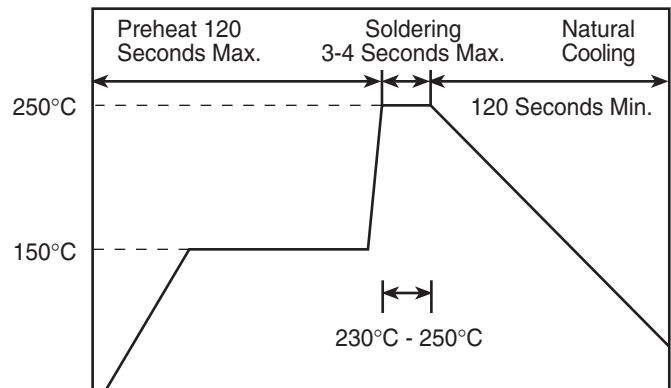

Recommended Condition for Iron Soldering

