

BASEBAND DELAY LINE

GENERAL DESCRIPTION

The KKA4661 is an integrated baseband delay line circuit with one line delay. It is suitable for decoders with colour-difference signal outputs \pm (R-Y) and \pm (B-Y). Device is functionally identical to the TDA4661 Philips.

FEATURES

- Two comb filters, using the switched-capacitor technique, for one line delay time (64 μ S)
- 3 MHz internal clock signal derived from a 6 MHz CCO, line-locked by the sandcastle pulse (64 μ S line)
- Comb filtering functions for NTSC colour-difference signals to suppress cross-colour
- Clamping of AC-coupled input signals \pm (R-Y) and \pm (B-Y)

QUICK REFERENCE DATA

Parameter	Symbol	Type $U_{VCC}=5.0$ V		
		Min.	Type	Max
Analogy supply current, mA	I_{p1}	-	-	6.0
Digital supply current, mA	I_{p2}	-	-	1.0
Input fixing voltage (on pins 14 and 16), V	$U_{14,16}$	1.3	-	1.7
Output voltage (on pins 11 and 12), V	$U_{11,12}$	2.5	-	3.3
Output signal (peak-to-peak value)				
\pm (R-Y) on pin 11	U_{011}	-	1.05	-
\pm (B-Y) on pin 12	U_{012}	-	1.33	-
Ratio of output amplitudes at equal input signals ($U_{14}=U_{16}=1.33$ V), dB	U_{11}/U_{12}	-0.4	-	0.4
Ratio of output signals on pins 11 and 12 for adjacent time samples at constant input signals ($U_{14}=U_{16}=1.33$ V), dB	U_n/U_{n+1}	-0.1	-	0.1
Gain for PAL and NTSC	G_v	5.3	-	6.3
Gain for SECAM (ratio U_o/U_i), dB		-0.6	-	0.4
Delay of delayed signals, μ S	t_d	63.94	-	64.06
Delay of non-delayed signals, nS	t_{dn}	40	-	80
Transient time of delayed signal on pins 11 respectively 12, nS	t_{tr}	-	350	-
Transient time of non-delayed signal on pins 11 respectively 12, nS	t_{trn}	-	320	-
Noise voltage (RMS value; pins 11 and 12), mV	U_n	-	-	1.2
Weighted signal-to-noise ratio, dB	S/N(w)	-	54	-

PIN CONFIGURATION



BLOCK DIAGRAM

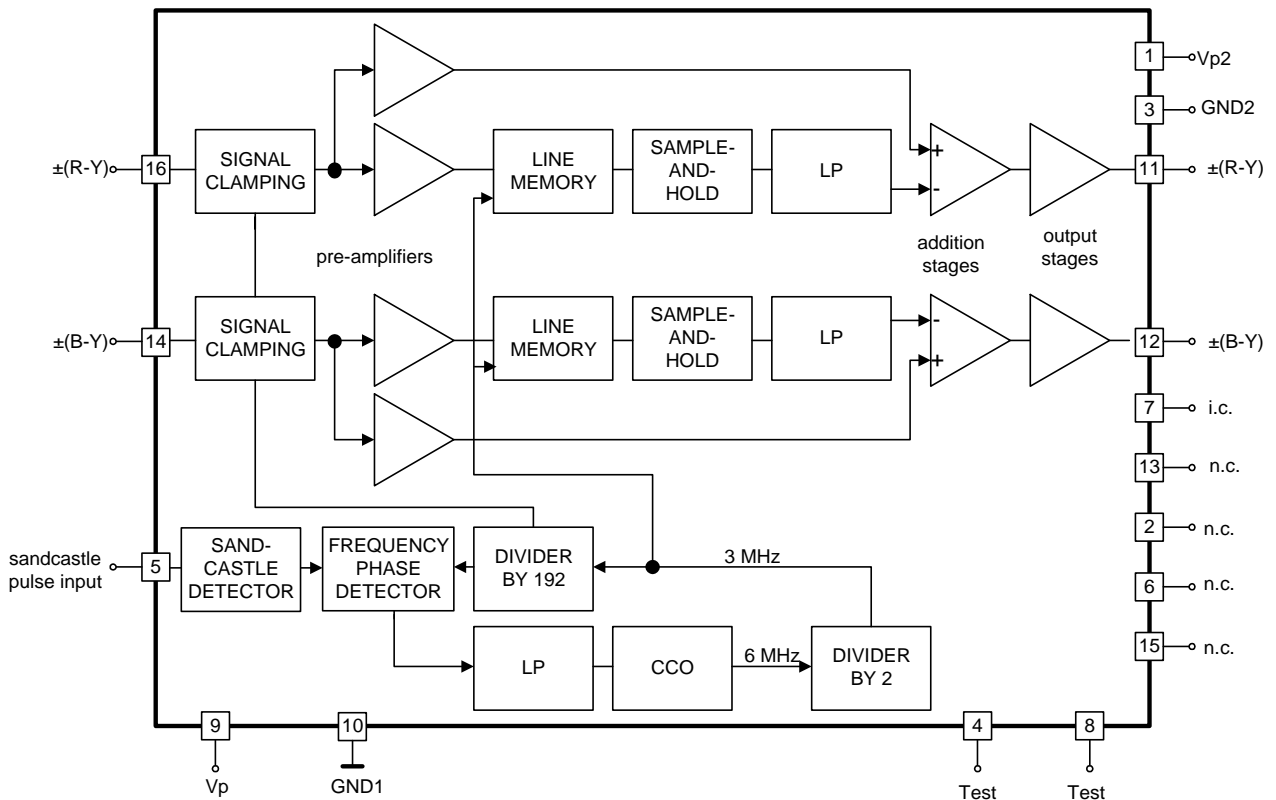

**N SUFFIX PLASTIC DIP
(MS - 001BB)**

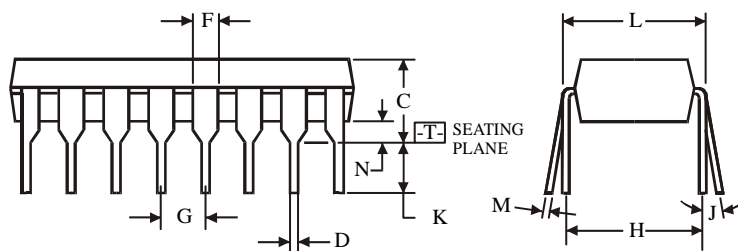
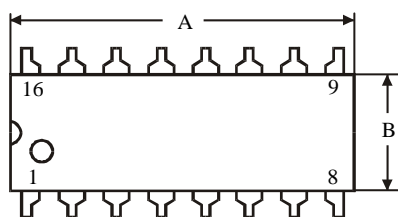
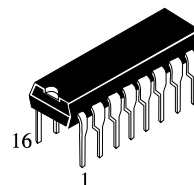

$\oplus 0.25 (0.010) \text{ (M) T}$

NOTES:

- Dimensions "A", "B" do not include mold flash or protrusions.
Maximum mold flash or protrusions 0.25 mm (0.010) per side.

Symbol	Dimension, mm	
	MIN	MAX
A	18.67	19.69
B	6.1	7.11
C		5.33
D	0.36	0.56
F	1.14	1.78
G	2.54	
H	7.62	
J	0°	10°
K	2.92	3.81
L	7.62	8.26
M	0.2	0.36
N	0.38	