

HIGH SPEED CMOS LOGIC IC ELM7SH66xB Analog switch

■ General description

ELM7SH66xB is CMOS analog switch. It realizes high speed operation with low power consumption by CMOS features. With low on resistance and high transmission rate, it realizes wider input voltage range.

■ Features

- Same electrical characteristic and high speed operation as 74VHC series
- Low consumption current : I_{dd}=1.0μA(Max.)(T_{op}=25°C)
- Wide power voltage range : 2.0V~5.5V
- Wide input voltage range : V_{ih}=5.5V(Max.)(V_{dd}=0~5.5V)
- High speed : T_{pd}=2ns(Typ.) (V_{dd}=5.0V)
- Small package : SOT-25, SSOT-25(SC-88A)
- Same function and pin configuration as ELM7SxxB

■ Application

- Cell phones
- Digital cameras
- Portable electrical appliances like PDA, etc.
- Computers and peripherals
- Digital electrical appliances like LCD TV sets, DVD recorders/players, STB, etc.
- Modification inside print board, adjustment of timing, solution to noise
- Power voltage change from 5V to 3V

■ Selection guide

ELM7SH66xB-EL

Symbol		
a	Function	66 : Analog switch
b	Package	M : SOT-25 T : SSOT-25(SC-88A)
c	Product version	B
d	Taping direction	EL : Refer to PKG file

ELM7SH $\overset{\uparrow}{\text{6}} \overset{\uparrow}{\text{6}}$ x $\overset{\uparrow}{\text{B}}$ - $\overset{\uparrow}{\text{EL}}$
 a b c d

■ Maximum absolute ratings

Parameter	Symbol	Limit	Unit
Power supply voltage	V _{dd}	-0.5~+6.0	V
Input voltage	V _{in}	-0.5~+6.0	V
Output voltage	V _{out}	-0.5~V _{dd} +0.5	V
Input protection diode current	I _{ik}	-20	mA
Output parasitic diode current	I _{ok}	±20	mA
Output current	I _{out}	±25	mA
VDD/GND current	I _{dd} , I _{gnd}	±50	mA
Power dissipation	P _d	150	mW
Storage temperature	T _{stg}	-65~+150	°C

HIGH SPEED CMOS LOGIC IC ELM7SH66xB Analog switch

■ Suggested operating condition

Parameter	Symbol	Limit		Unit
Power voltage	Vdd	2.0~5.5		V
Input voltage	Vin	0~5.5		V
Output voltage	Vout	0~Vdd		V
Operating temperature	Top	-40~+85		°C
High-input down-time	tr, tf	Vdd=3.3±0.3V	0~200	ns
		Vdd=5.0±0.5V	0~100	

■ Pin configuration

TOP VIEW

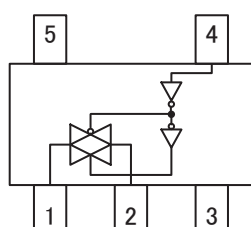

Pin No.	Pin name
1	IN/OUT
2	OUT/IN
3	GND
4	CONTROL
5	VDD

Control	Switch
Low	OFF
High	ON

■ AC electrical characteristics

tr=tf=3ns

Parameter	Sym.	Vdd	Top=25°C			Top=-40~+85°C		Unit	Condition
			Min.	Typ.	Max.	Min.	Max.		
Propagation delay-time	tPLH	2.0		4	20		23	ns	CL=50pF RL=10kΩ
	tPHL	3.3		3	6		8		
		5.0		2	5		6		
Output enable-time	tZL	2.0		9	50		65	ns	CL=50pF RL=1kΩ
	tZH	3.3		5	10		12		
		5.0		3	8		10		
Output disable-time	tLZ	2.0		12	60		75	ns	CL=50pF RL=1kΩ
	tHZ	3.3		10	23		27		
		5.0		8	20		25		
Maximum control input frequency	fin	2.0		30				MHz	CL=15pF RL=1kΩ Vout=Vdd/2
		3.0		30					
		4.5		30					
Control input capacity	Cin			5	10		10	pF	
SW-input/output capacity	Cin/out			6				pF	
Feed-through capacity	Cin-out			0.5				pF	
Equivalent inner capacity	Cpd			13				pF	

* Cpd is IC's inner equivalent capacity which is calculated from non-loaded operating current consumption referred to test circuit. Averaged operating current consumption at non load is calculated as following formula; $I_{dd}(opr) = Cpd \cdot Vdd \cdot fin + I_{dd}$

HIGH SPEED CMOS LOGIC IC ELM7SH66xB Analog switch

■ DC electrical characteristics

Parameter	Sym.	Vdd	Top=25°C			Top=-40~+85°C		Unit	Condition
			Min.	Typ.	Max.	Min.	Max.		
Input voltage	Vih	2.0	1.50			1.50		V	
		3.0	2.10			2.10			
		5.5	3.85			3.85			
	Vil	2.0			0.50		0.50	V	
		3.0			0.90		0.90		
		5.5			1.65		1.65		
ON-resister	Ron	2.0		130	350		550	Ω	Vcont=Vdd Vin=0~Vdd Iin/out=1mA
		3.0		22	50		65		
		4.5		12	25		35		
SW-OFF leak-current	IS (OFF)	5.5	-0.1		0.1	-1.0	1.0	μA	Vcont=GND Vin=Vdd Vout=GND
SW-ON leak-current	IS (ON)	5.5	-0.1		0.1	-1.0	1.0	μA	Vcont=Vdd Vin=Vdd or GND
Cont input current	Icont	5.5	-0.1		0.1	-1.0	1.0	μA	Vin=Vdd or GND
Static current	Idd	5.5			1.0		5.0	μA	Vin=Vdd or GND

■ Test circuit

- Ron : ON resister

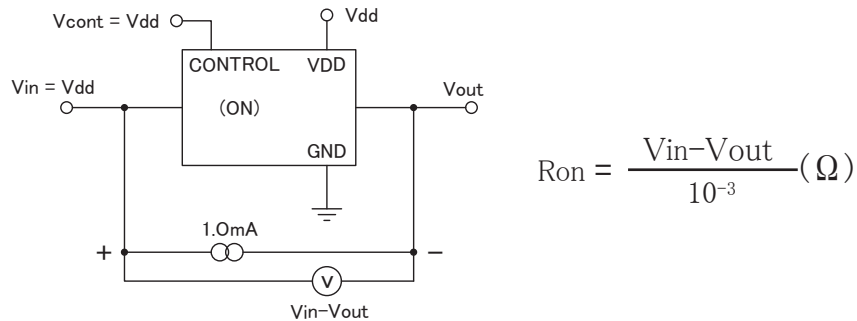

- IS(OFF) : SW-OFF leak

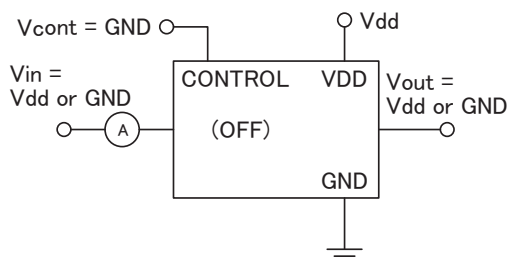

- IS(ON) : SW-ON leak current

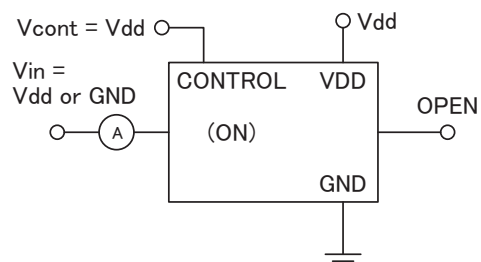

HIGH SPEED CMOS LOGIC IC ELM7SH66xB Analog switch

- t_{PLH} , t_{PHL} : Propagation delay-time (SW-input→SW-output)

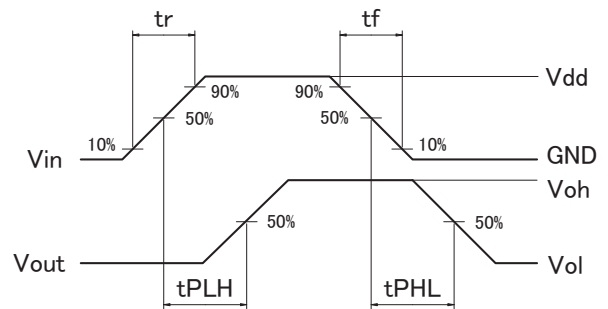
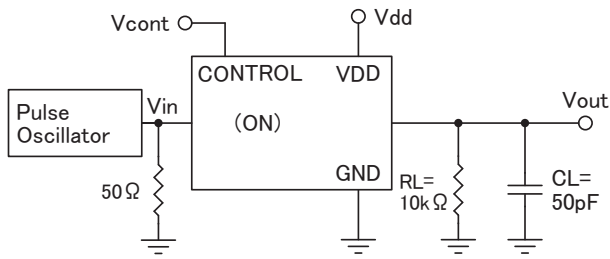

- t_{ZH} , t_{ZL}/t_{HZ} , t_{LZ} : Output enable time, Output disable time

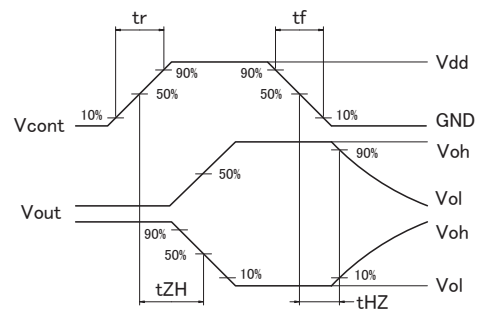
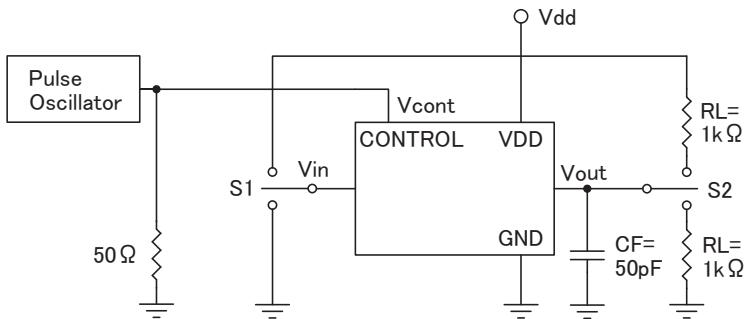

	t_{ZH}	t_{ZL}	t_{HZ}	t_{LZ}
S1	Vdd	GND	Vdd	GND
S2	GND	Vdd	GND	Vdd

- Maximum controlled input frequency

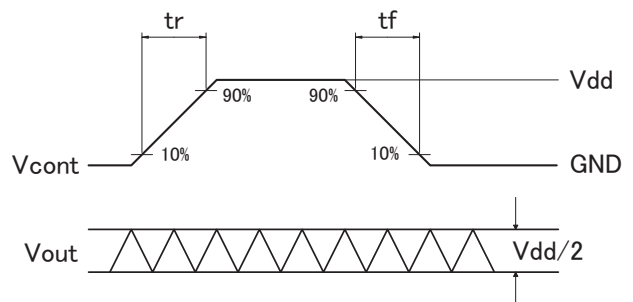
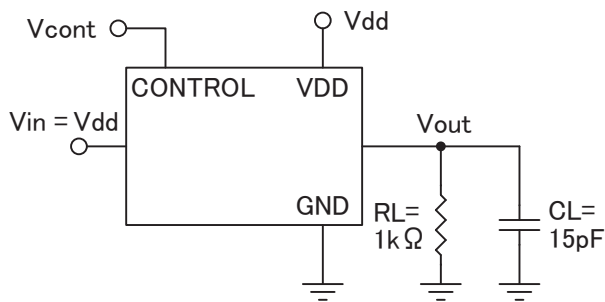

Note : Input duty cycle 50%

■ Marking

SOT-25

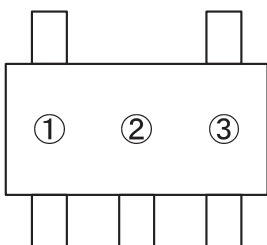

SSOT-25

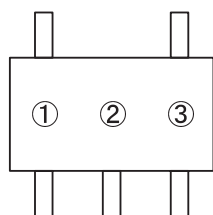

No.	Mark	Content
①	F	ELM7SH series
②	9	ELM7SH66xB
③	A~Z (except I, O, X)	Lot No.