

PMB 8877

S-GOLD₃[™] - Turbo Engine for
EDGE-enabled Multimedia Phones



S-GOLD₃[™] TAKES Infineon Technology's well-known S-GOLD[®] architecture to new performance spheres. Its performance-optimized implementation nearly doubles the multimedia power of previous S-GOLD[®] controllers. High processor speed combined with multimedia hardware accelerators and advanced connectivity make this device the "turbo engine" of the S-GOLD[®] family. Even the most performance-greedy applications such as video telephony and 3D graphics can easily be handled without additional hardware. S-GOLD₃[™]'s proven architecture known as "application-enhanced modem" is extremely efficient with respect to overall system cost, footprint, feature set, power consumption, and application performance. Its EDGE capable modem marks the third generation of Infineon's EDGE-enabled baseband solutions. Configurable with a UMTS co-processor, S-GOLD₃[™] extends into the growing 3G market, offering easy migration from a GSM/GPRS/EGPRS phone to a dual-mode wideband CDMA/GSM terminal.

AS NEXT-GENERATION mobile phones go further and further beyond pure communication functionality, S-GOLD₃[™] offers cost-optimized access to multimedia functions such as camera support of up to 5 MPixel (with JPEG camera module), video replay up to 15 fps/CIF resolution, video streaming over EDGE in MPEG4/H.264/Real format, video recording, and advanced audio codecs like AAC++. Supporting all this functionality without the need for additional hardware, S-GOLD₃[™] enables a true 3-chip system solution with minimum cost and size requirements. For even more demanding feature need S-GOLD₃[™] is configurable with a number of co-devices such as multimedia companion chips and/or WCDMA co-modem for 3G feature phones.

S-GOLD₃[™]'S[™] OVERALL SYSTEM performance is based on the outstanding processor speed of its ARM[®]926 CPU which is tailored to run at up to 312 MHz. Data and instruction caches as well as general-purpose zero-wait-state memories allow for fast memory access, fully exploiting the processing power of the CPU core. To keep power consumption at a minimum several power measures control the activation, the frequency selection, and the power-down modes of the various on-chip resources. To enable efficient access to external memory devices S-GOLD₃[™] allows for low-latency access to a number of memory types such as NOR/NAND Flash, SDRAM, cellular RAM, PSRAM. DDR SDRAMs can be operated "high speed", transferring data twice per clock cycle.

COMBINED WITH Infineon's latest SMARTi[™] RF devices and SM-POWER[™] power management ICs, S-GOLD₃[™] comprises the system solution for next-generation, EDGE-enabled mobile phones with minimum bill-of-material and space constraints.

Key Application Features

- ARM[®]926 based single modem and application processor with cache support and fast tightly-coupled memories
- Parallel/serial display interface supporting high resolution color displays
- High-speed serial display interface for cost-effective clam-shell mechanics
- Camera interface supporting camera applications of up to 5 MPixel
- MPEG4/H.263 accelerator hardware (MOVE[®] coprocessor)
- 2x MMC/SD interfaces, SD IO capable
- USB 2.0 on-the-go, full speed
- Fast IRDA
- Dedicated NAND flash controller supporting burst mode and error detection
- Standardized multimedia extension interface (MMIC-IF) supporting external hardware accelerator ICs such as complex display/camera modules or graphic accelerators
- 2 bi-directional digital audio interfaces (I²S) to connect audio companion ICs and Bluetooth modules
- Support for video streaming + video telephony
- Support of DDR-SDRAM devices

Key Modem Features

- E-GPRS/GPRS/GSM modem supporting up to multislots class 12
- FR, HR, EFR, AMR
- HSCSD class 10
- SAIC
- DTM class 11
- Polyphonic Ringer support for up to 64 voices at up to 48 kHz sampling rate
- Echo cancellation/noise reduction
- GTT/TTY

www.infineon.com/mobilesolutions

Mobile Solutions



Never stop thinking

Application Example Quad-Band EGPRS Solution

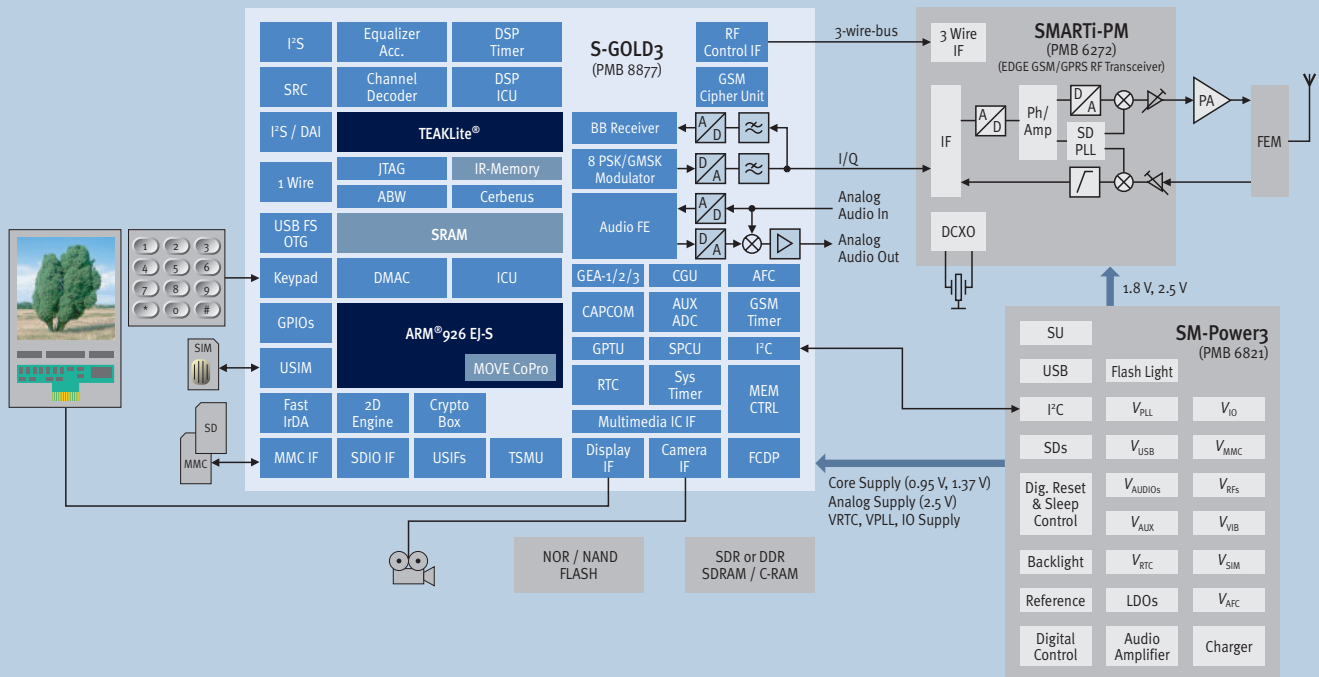

Applications

- E-GPRS/GPRS/GSM multimedia phones with tomorrow's multimedia requirements
- Minimum space E-GPRS/GPRS data modules supporting up to multislot class 12
- WCDMA phone and data module applications (in combination with WCDMA co-processor)

Key Benefits

- High integration level of key multimedia features allowing for minimum cost system solutions for tomorrow's feature phones
- High overall system performance with high-speed ARM subsystem and double-data rate memory access
- Proven leading-edge modem technology with third generation E-GPRS evolution
- Feature flexibility through upgrade options with multimedia chips via standardized interface
- 3G upgradeable with WCDMA coprocessor
- Connectivity to Bluetooth, FM Radio, WLAN, A-GPS and other modules

Note: TEAKLite® is a registered trademark of ParthusCeva, Ltd.
ARM® is a registered trademark of ARM, Ltd.

How to reach us:
<http://www.infineon.com>

Published by
Infineon Technologies AG
81726 München, Germany

© Infineon Technologies AG 2006.
All Rights Reserved.

Attention please!

The information herein is given to describe certain components and shall not be considered as a guarantee of characteristics. Terms of delivery and rights to technical change reserved.

We hereby disclaim any and all warranties, including but not limited to warranties of non-infringement, regarding circuits, descriptions and charts stated herein.

Information

For further information on technology, delivery terms and conditions and prices please contact your nearest Infineon Technologies Office.

Warnings

Due to technical requirements components may contain dangerous substances. For information on the types in question please contact your nearest Infineon Technologies Office.

Infineon Technologies Components may only be used in life-support devices or systems with the express written approval of Infineon Technologies, if a failure of such components can reasonably be expected to cause the failure of that life-support device or system, or to affect the safety or effectiveness of that device or system. Life support devices or systems are intended to be implanted in the human body, or to support and/or maintain and sustain and/or protect human life. If they fail, it is reasonable to assume that the health of the user or other persons may be endangered.

Ordering No. B134-H8540-G1-X-7600
Printed in Germany
PS 01061. nb