

Small Package, High Performance, Asynchronous Boost for 10 WLED Driver

General Description

The RT9293 is a high frequency, asynchronous boost converter. The internal MOSFET can support up to 10 White LEDs for backlighting and OLED power application, and the internal soft start function can reduce the inrush current. The device operates with 1-MHz fixed switching frequency to allow small external components and to simplify possible EMI problems. For the protection, the RT9293A provides 50V OVP and the RT9293B provides 50V/20V OVP to allow inexpensive and small-output capacitors with lower voltage ratings. The LED current is initially set with the external sense resistor R_{SET} . The RT9293 is available in the tiny package type TSOT-23-6 and WDFN-8L 2x2 packages to provide the best solution for PCB space saving and total BOM cost.

Ordering Information

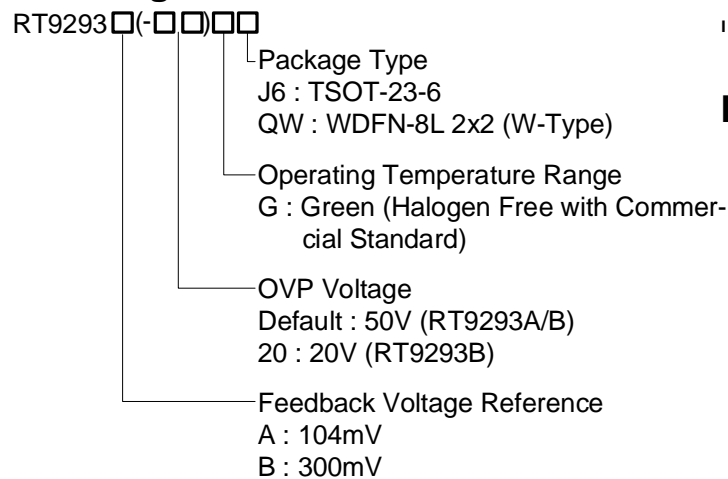

Note :

- Richtek Green products are :
 - } RoHS compliant and compatible with the current requirements of IPC/JEDEC J-STD-020.
 - } Suitable for use in SnPb or Pb-free soldering processes.

Marking Information

For marking information, contact our sales representative directly or through a Richtek distributor located in your area, otherwise visit our website for detail.

Features

- | VIN Operating Range : 2.5V to 5.5V
- | Internal Power N-MOSFET Switch
- | Wide Range for PWM Dimming (100Hz to 200kHz)
- | Minimize the External Component Counts
- | Internal Soft Start
- | Internal Compensation
- | Under Voltage Protection
- | Over Voltage Protection
- | Over Temperature Protection
- | Small TSOT-23-6 and 8-Lead WDFN Packages
- | RoHS Compliant and Halogen Free

Applications

- | Cellular Phones
- | Digital Cameras
- | PDAs and Smart Phones and MP3 and OLED.
- | Portable Instruments

Pin Configurations

(TOP VIEW)

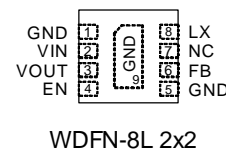
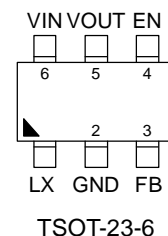

Typical Application Circuit

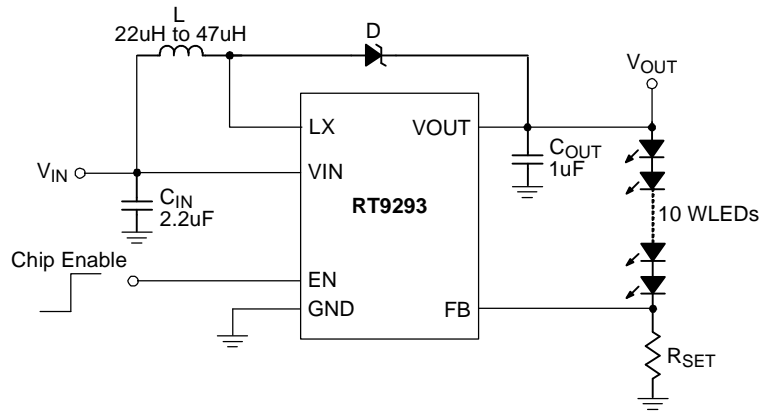

Functional Pin Description

Pin No.		Pin Name	Pin Function
RT9293□GJ6	RT9293□GQW		
1	8	LX	Switching Pin.
2	1, 5, 9 (Exposed pad)	GND	Ground Pin. The exposed pad must be soldered to a large PCB and connected to GND for maximum power dissipation.
3	6	FB	Feedback Pin, put a resistor to GND to setting the current.
4	4	EN	Chip Enable (Active High).
5	3	VOUT	Output Voltage Pin.
6	2	VIN	Input Supply.
--	7	NC	No Internal Connection.

Function Block Diagram

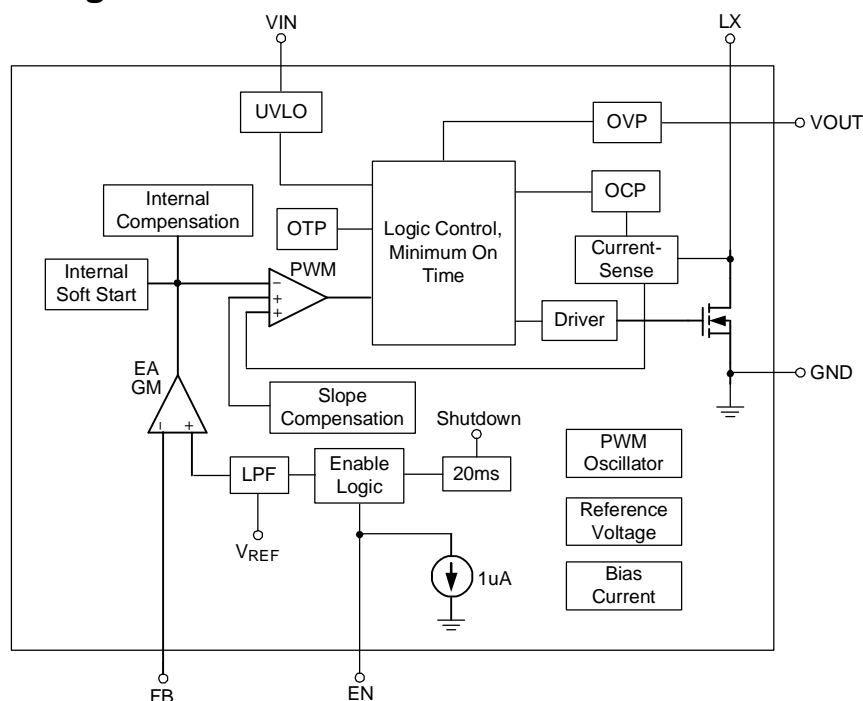

Absolute Maximum Ratings (Note 1)

Supply Input Voltage, V_{IN} -----	-0.3V to 6V
Switching Pin, LX -----	-0.3V to 50V
VOUT -----	-0.3V to 46V
Other Pins -----	-0.3V to 6V
Power Dissipation, P_D @ $T_A = 25^\circ\text{C}$	
TSOT-23-6 -----	0.392W
WDFN-8L 2x2 -----	0.606W
Package Thermal Resistance (Note 3)	
TSOT-23-6, θ_{JA} -----	255°C/W
WDFN-8L 2x2, θ_{JA} -----	165°C/W
WDFN-8L 2x2, θ_{JC} -----	20°C/W
Lead Temperature (Soldering, 10 sec.)-----	260°C
Junction Temperature -----	150°C
Storage Temperature Range -----	-65°C to 150°C

Recommended Operating Conditions (Note 2)

Junction Temperature Range -----	-40°C to 125°C
Ambient Temperature Range -----	-40°C to 85°C

Electrical Characteristics

($V_{IN} = 3.7\text{V}$, $C_{IN} = 2.2\mu\text{F}$, $C_{OUT} = 0.47\mu\text{F}$, $I_{OUT} = 20\text{mA}$, $L = 22\mu\text{H}$, $T_A = 25^\circ\text{C}$, unless otherwise specified)

Parameter	Symbol	Conditions	Min	Typ	Max	Unit
Input Voltage	V_{IN}		2.5	--	5.5	V
Under Voltage Lock Out	V_{UVLO}		2	2.2	2.45	V
UVLO Hysteresis			-	0.1	--	V
Quiescent Current	I_Q	FB = 1.5V, No Switching	-	400	600	uA
Supply Current	I_{IN}	FB = 0V, Switching	-	1	2	mA
Shutdown Current	I_{SHDN}	$V_{EN} < 0.4\text{V}$	-	1	4	uA
Line Regulation		$V_{IN} = 3$ to 4.3V	-	1	--	%
Load Regulation		1mA to 20mA	-	1	--	%
Operation Frequency	fosc		0.75	1	1.25	MHz
Maximum Duty Cycle			90	92	--	%
Clock Rate			0.1	--	200	kHz
Feedback Reference Voltage	RT9293A	V_{REF}	94	104	114	mV
	RT9293B		285	300	315	
On Resistance	$R_{DS(ON)}$		-	0.7	1.2	Ω

To be continued

Parameter		Symbol	Conditions	Min	Typ	Max	Unit
EN Threshold	Logic-High Voltage	V_{IH}		1.4	--	--	V
	Logic-Low Voltage	V_{IL}		--	--	0.5	V
EN Sink Current		I_{IH}		--	1	--	uA
EN Hysteresis				--	0.1	--	V
Over-Voltage Threshold	OVP = 50V	V_{OVP}		42	46	50	V
	RT9293B-20			16	17.5	20	
Over-Current Threshold		I_{OCP}		1	1.2	--	A
OTP		T_{OTP}		--	160	--	°C
OTP Hysteresis				--	30	--	°C
Shutdown Delay		T_{SHDN}		--	20	--	ms

Note 1. Stresses listed as the above "Absolute Maximum Ratings" may cause permanent damage to the device. These are for stress ratings. Functional operation of the device at these or any other conditions beyond those indicated in the operational sections of the specifications is not implied. Exposure to absolute maximum rating conditions for extended periods may remain possibility to affect device reliability.

Note 2. The device is not guaranteed to function outside its operating conditions.

Note 3. θ_{JA} is measured in the natural convection at $T_A = 25^\circ\text{C}$ on a low effective single layer thermal conductivity test board of JEDEC 51-3 thermal measurement standard. The case point of θ_{JC} is on the expose pad for the WDFN package.

Typical Operating Characteristics

Efficiency vs. Output Current

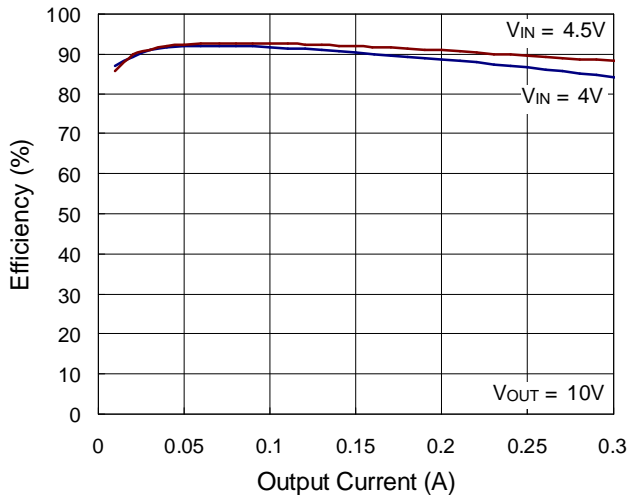

Efficiency vs. Input Voltage

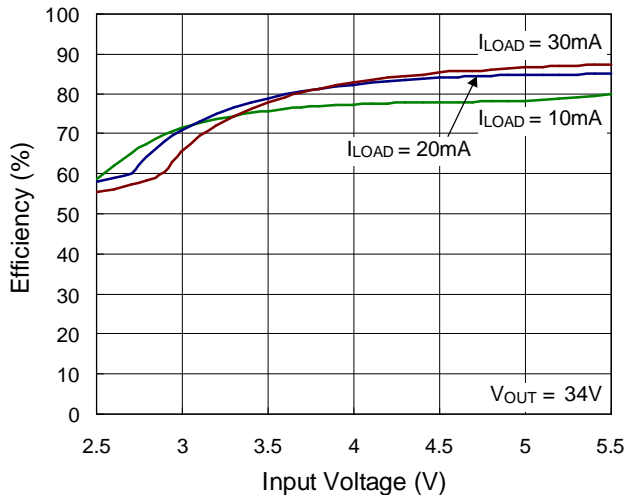

Output Voltage vs. Output Current

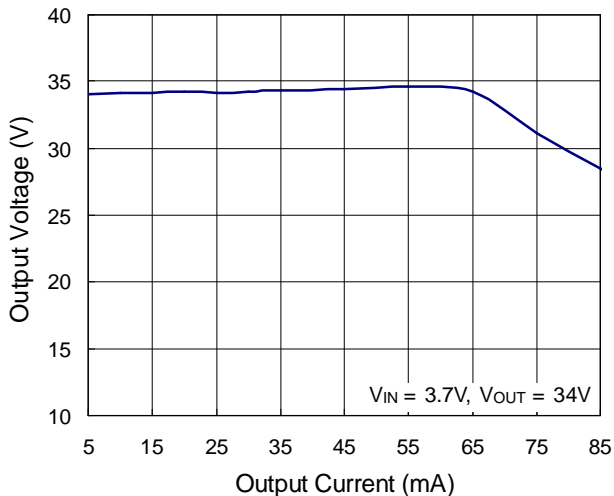

Quiescent Current vs. Input Voltage

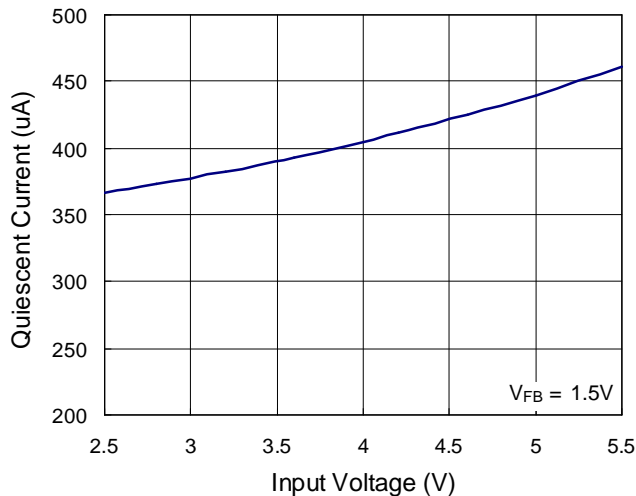

Frequency vs. Input Voltage

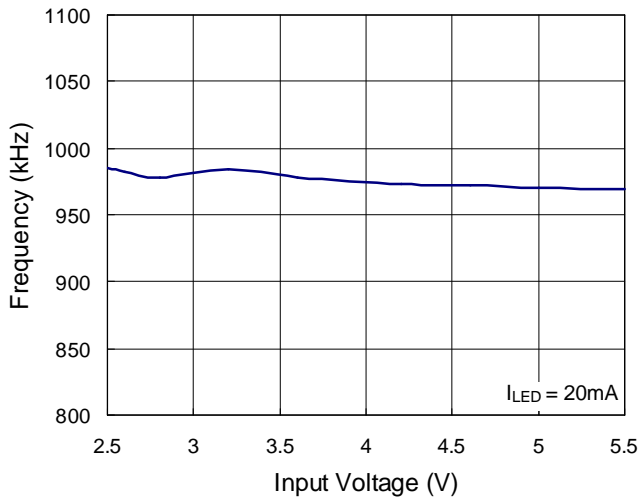

Frequency vs. Temperature

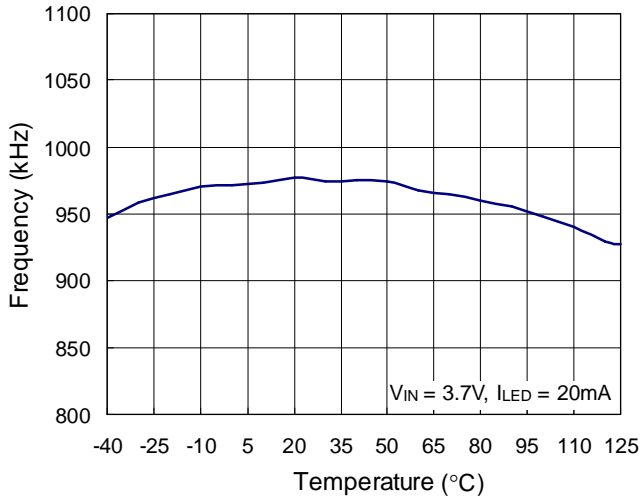

Reference Voltage vs. Input Voltage

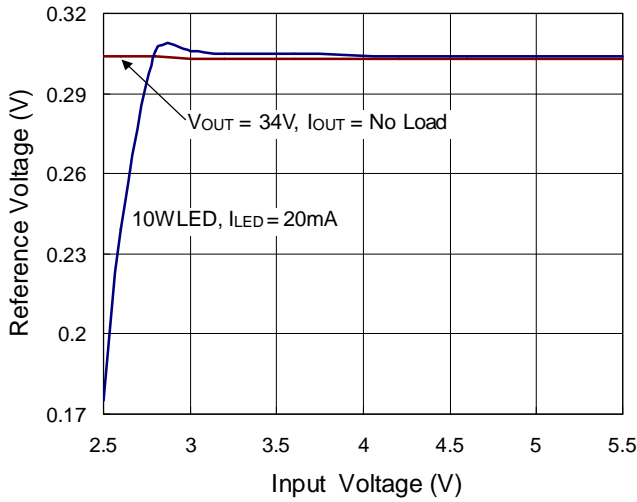

Reference Voltage vs. Temperature

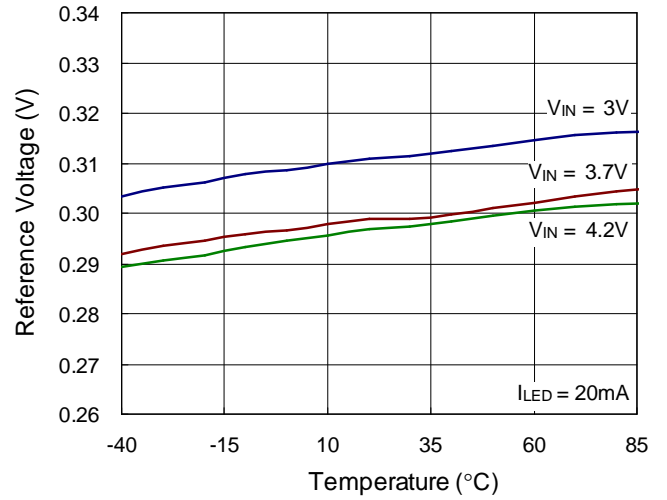

Reference Voltage vs. Output Current

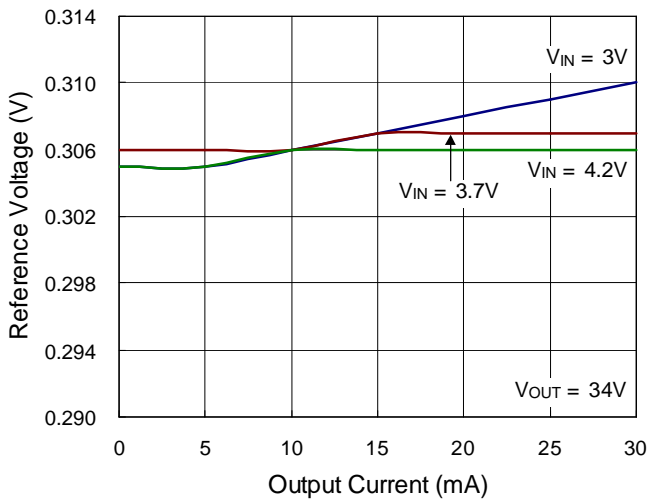

Enable Threshold vs. Input Voltage

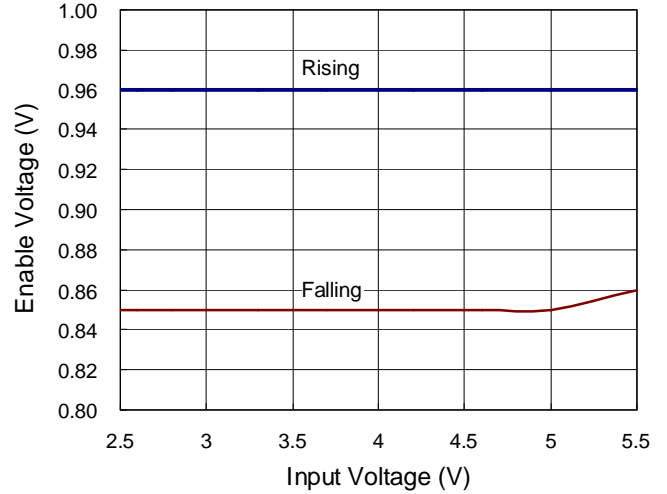

LED Current vs. Duty

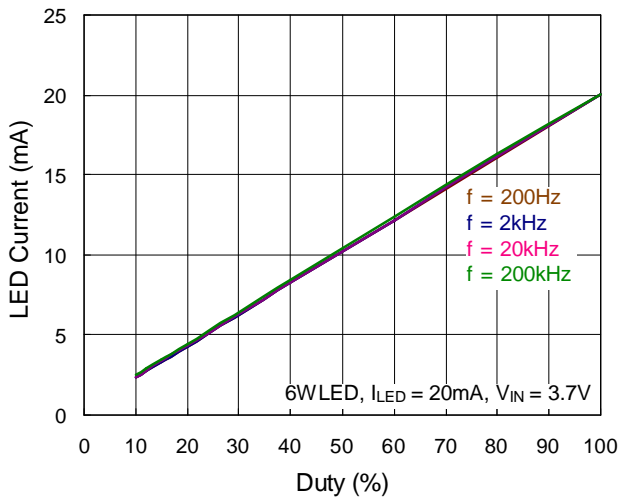

Power On from EN

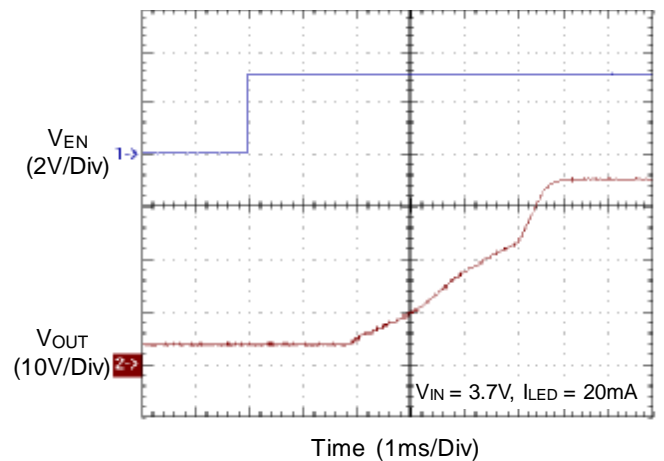

Power Off from EN

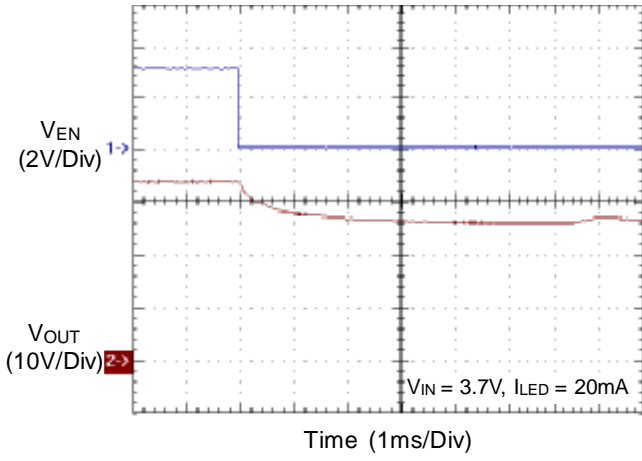

Ripple Voltage

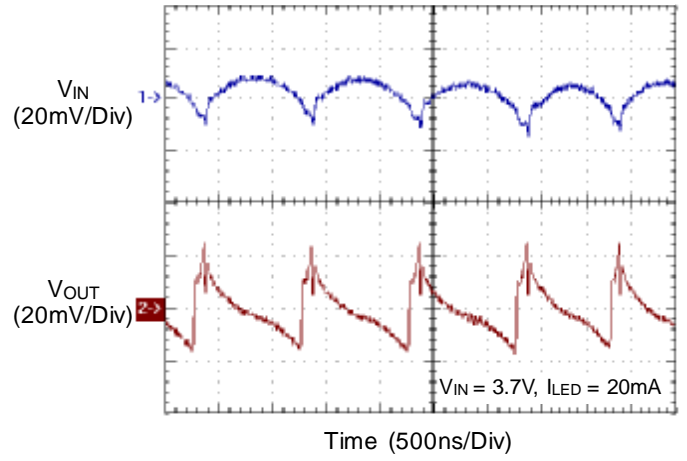

PWM Dimming from EN

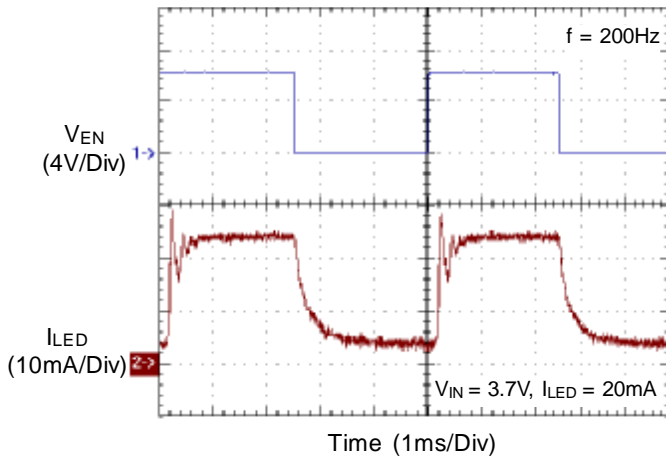

PWM Dimming from EN

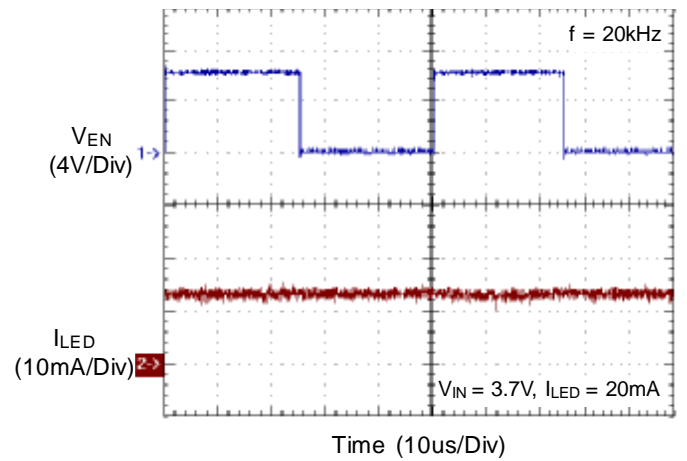

Applications Information

LED Current Setting

The loop of Boost structure will keep the FB pin voltage equal to the reference voltage V_{REF} . Therefore, when R_{SET} connects FB pin and GND, the current flows from V_{OUT} through LED and R_{SET} to GND will be decided by the current on R_{SET} , which is equal to following equation.

$$I_{LED} = \frac{V_{REF}}{R_{SET}}$$

Dimming Control

a. Using a PWM Signal to EN Pin

For the brightness dimming control of the RT9293, the IC provides typically 300mV feedback voltage when the EN pin is pulled constantly high. However, EN pin allows a PWM signal to reduce this regulation voltage by changing the PWM duty cycle to achieve LED brightness dimming control. The relationship between the duty cycle and FB voltage can be calculated as following equation.

$$V_{FB} = \text{Duty} \times 300\text{mV}$$

Where

Duty = duty cycle of the PWM signal

300mV = internal reference voltage

As shown in Figure 1, the duty cycle of the PWM signal is used to cut the internal 300mV reference voltage. An internal low pass filter is used to filter the pulse signal. And then the reference voltage can be made by connecting the output of the filter to the error amplifier for the FB pin voltage regulation.

However, the internal low pass filter 3db frequency is 500Hz. When the dimming frequency is lower than 500Hz, V_A is also a PWM signal and the LED current is controlled directly by this signal. When the frequency is higher than 500Hz, PWM is filtered by the internal low pass filter and the V_A approach a DC signal. And the LED current is a DC current which eliminate the audio noise. Two figures of PWM Dimming from EN are shown in Typical Operating Characteristics section and the PWM dimming frequency is 200Hz and 20kHz respectively.

But there is an offset in error amplifier which will cause the V_A variation. In low PWM duty signal situation, the

filtered reference voltage is low and the offset can cause bigger variation of the output current. So the RT9293A is not recommend to be dimming by the EN pin. For the RT9293B, the minimum duty vs frequency is listed in following table.

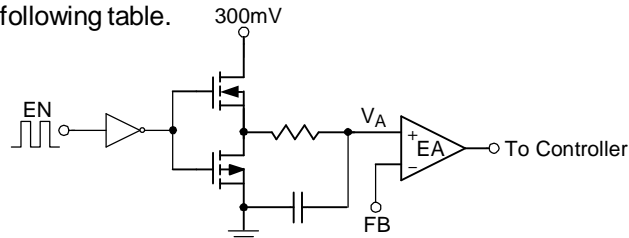

Figure 1. Block Diagram of Programmable FB Voltage Using PWM Signal

	Duty Minimum
Dimming frequency < 500Hz	4%
Dimming frequency > 500Hz	10%

b. Using a DC Voltage

Using a variable DC voltage to adjust the brightness is a popular method in some applications. The dimming control using a DC voltage circuit is shown in Figure 2. As the DC voltage increases, the current flows through R3 increasingly and the voltage drop on R3 increase, i.e. the LED current decreases. For example, if the V_{DC} range is from 0V to 2.8V and assume the RT9293 is selected which V_{REF} is equal to 0.3V, the selection of resistors in Figure 2 sets the LED current from 21mA to 0mA. The LED current can be calculated by the following equation.

$$I_{LED} = \frac{V_{REF} - \frac{R3 \times (V_{DC} - V_{REF})}{R4}}{R_{SET}}$$

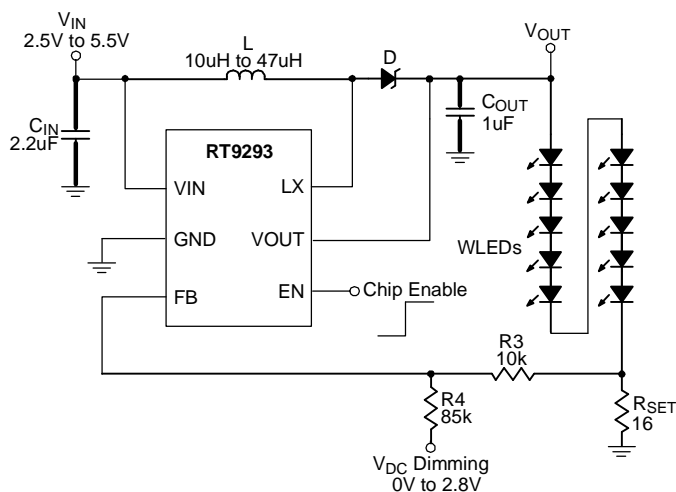

Figure 2. Dimming Control Using a DC Voltage

c. Using a Filtered PWM signal

Another common application is using a filtered PWM signal as an adjustable DC voltage for LED dimming control. A filtered PWM signal acts as the DC voltage to regulate the output current. The recommended application circuit is shown as Figure 3. In this circuit, the output ripple depends on the frequency of PWM signal. For smaller output voltage ripple (<100mV), the recommended frequency of 2.8V PWM signal should be above 2kHz. To fix the frequency of PWM signal and change the duty cycle of PWM signal can get different output current. The LED current can be calculated by the following equation.

$$I_{LED} = \frac{V_{REF} - \frac{R3 \times (V_{PWM} \times Duty - V_{REF})}{R4 + R_{DC}}}{R_{SET}}$$

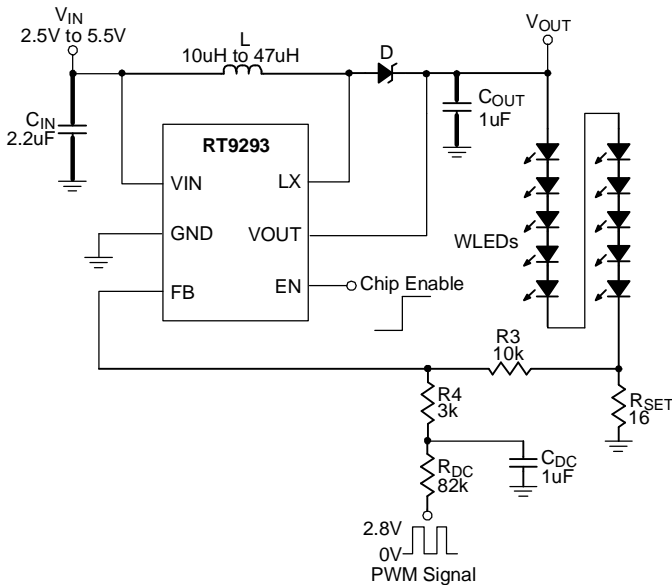

Figure 3. Dimming Control Using a Filtered PWM Signal

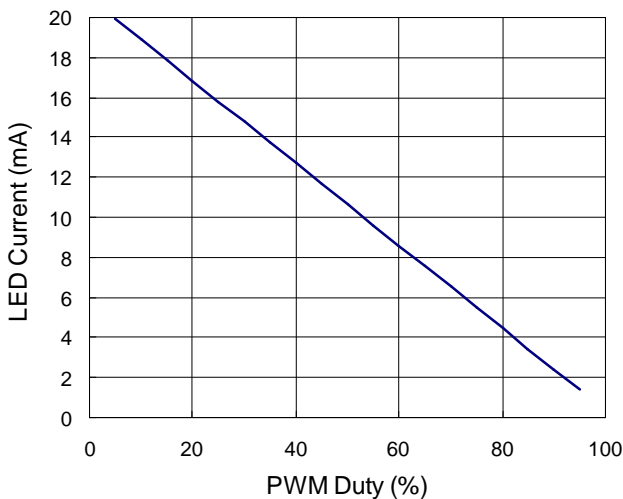

Figure 4. PWM Duty Cycle vs. LED Current

By the above equation and the application circuit shown in Figure 3, and assume the RT9293 is selected which V_{REF} is equal to 0.3V. Figure 4 shows the relationship between the LED current and PWM duty cycle. For example, when the PWM duty is equal to 60%, the LED current will be equal to 8.6mA. When the PWM duty is equal to 40%, the LED current will be equal to 12.7mA.

Constant Output Voltage Control

The output voltage of the R9293 can be adjusted by the divider circuit on the FB pin. Figure 5 shows the application circuit for the constant output voltage. The output voltage can be calculated by the following Equations.

$$V_{OUT} = V_{REF} \times \frac{R1 + R2}{R2} ; R2 > 10k$$

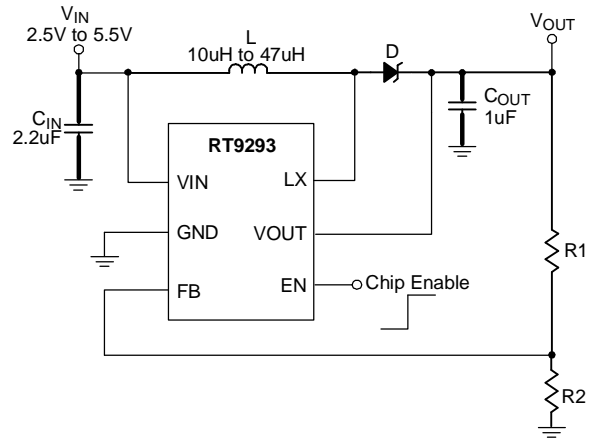

Figure 5. Constant Output Voltage Application

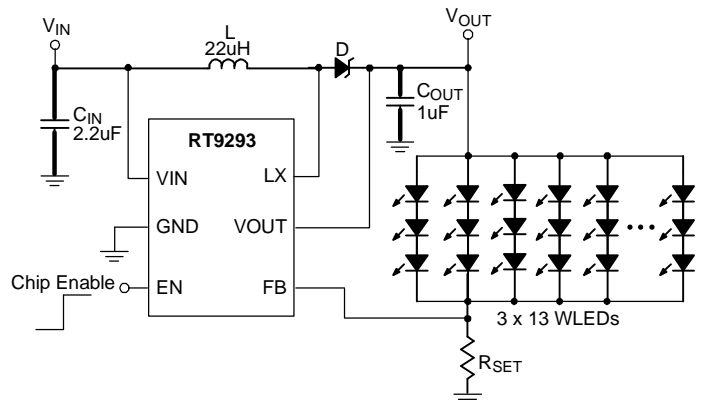

Figure 6. Application for Driving 3 X 13 WLEDs

Application for Driving 3 x 13 WLEDs

The RT9293 can drive different WLEDs topology. For example, the Figure 6 shows the 3x13 WLEDs and total current is equal to 260mA. The total WLEDs current can be set by the R_{SET} which is equal to following equation.

$$I_{Total} = \frac{V_{REF}}{R_{SET}}$$

Power Sequence

In order to assure the normal soft start function for suppressing the inrush current the input voltage should be ready before EN pulls high.

Soft-Start

The function of soft-start is made for suppressing the inrush current to an acceptable value at the beginning of power-on. The RT9293 provides a built-in soft-start function by clamping the output voltage of error amplifier so that the duty cycle of the PWM will be increased gradually in the soft-start period.

Current Limiting

The current flow through inductor as charging period is detected by a current sensing circuit. As the value comes across the current limiting threshold, the N-MOSFET will be turned off so that the inductor will be forced to leave charging stage and enter discharging stage. Therefore, the inductor current will not increase over the current limiting threshold.

OVP/UVLO/OTP

The Over Voltage Protection is detected by a junction breakdown detecting circuit. Once V_{OUT} goes over the detecting voltage, LX pin stops switching and the power N-MOSFET will be turned off. Then, the V_{OUT} will be clamped to be near V_{OVP} . As the output voltage is higher than a specified value or input voltage is lower than a specified value, the chip will enter protection mode to prevent abnormal function. As the die temperature is higher than 160°C, the chip also will enter protection mode. The power MOSFET will be turned off during protection mode to prevent abnormal operation.

Inductor Selection

The recommended value of inductor for 10 WLEDs applications is from 10uH to 47uH. Small size and better efficiency are the major concerns for portable devices, such as the RT9293 used for mobile phone. The inductor should have low core loss at 1MHz and low DCR for better efficiency. The inductor saturation current rating should be considered to cover the inductor peak current.

Capacitor Selection

Input ceramic capacitor of 2.2uF and output ceramic capacitor of 1uF are recommended for the RT9293 applications for driving 10 series WLEDs. For better voltage filtering, ceramic capacitors with low ESR are recommended. X5R and X7R types are suitable because of their wider voltage and temperature ranges.

Thermal Considerations

For continuous operation, do not exceed absolute maximum operation junction temperature. The maximum power dissipation depends on the thermal resistance of IC package, PCB layout, the rate of surroundings airflow and temperature difference between junction to ambient. The maximum power dissipation can be calculated by following formula :

$$P_{D(MAX)} = (T_{J(MAX)} - T_A) / \theta_{JA}$$

Where $T_{J(MAX)}$ is the maximum operation junction temperature, T_A is the ambient temperature and the θ_{JA} is the junction to ambient thermal resistance.

For the recommended operating conditions specification of RT9293, the maximum junction temperature of the die is 125°C. The junction to ambient thermal resistance θ_{JA} is layout dependent. The junction to ambient thermal resistance for TSOT-23-6 package is 255°C/W and for WDFN-8L 2x2 package is 165°C/W on the standard JEDEC 51-3 single layer thermal test board. The maximum power dissipation at $T_A = 25^\circ\text{C}$ can be calculated by following formula :

$$P_{D(MAX)} = (125^\circ\text{C} - 25^\circ\text{C}) / (165^\circ\text{C/W}) = 0.606\text{W for WDFN-8L 2x2 packages}$$

$$P_{D(MAX)} = (125^\circ\text{C} - 25^\circ\text{C}) / (255^\circ\text{C/W}) = 0.392\text{W for TSOT-23-6 packages}$$

The maximum power dissipation depends on operating ambient temperature for fixed $T_{J(MAX)}$ and thermal resistance θ_{JA} . For RT9293 packages, the Figure 7 of derating curves allows the designer to see the effect of rising ambient temperature on the maximum power allowed.

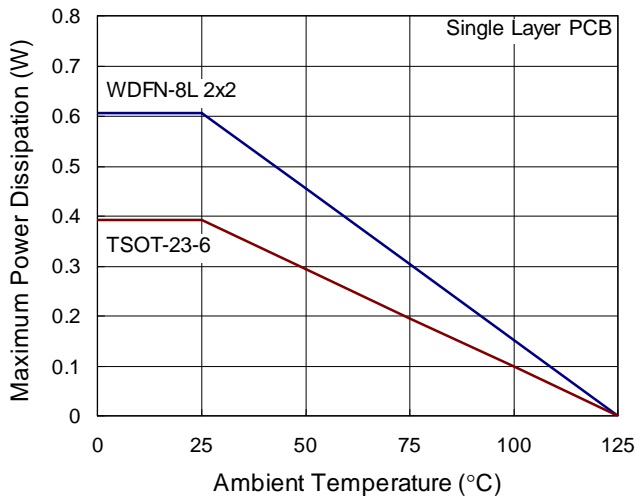

Figure 7. Derating Curves for RT9293 Packages

Layout Consideration

For best performance of the RT9293, the following guidelines must be strictly followed.

- } Input and Output capacitors should be placed close to the IC and connected to ground plane to reduce noise coupling.
- } The GND and Exposed Pad should be connected to a strong ground plane for heat sinking and noise protection.
- } Keep the main current traces as possible as short and wide.
- } LX node of DC-DC converter is with high frequency voltage swing. It should be kept at a small area.
- } Place the feedback components as close as possible to the IC and keep away from the noisy devices.

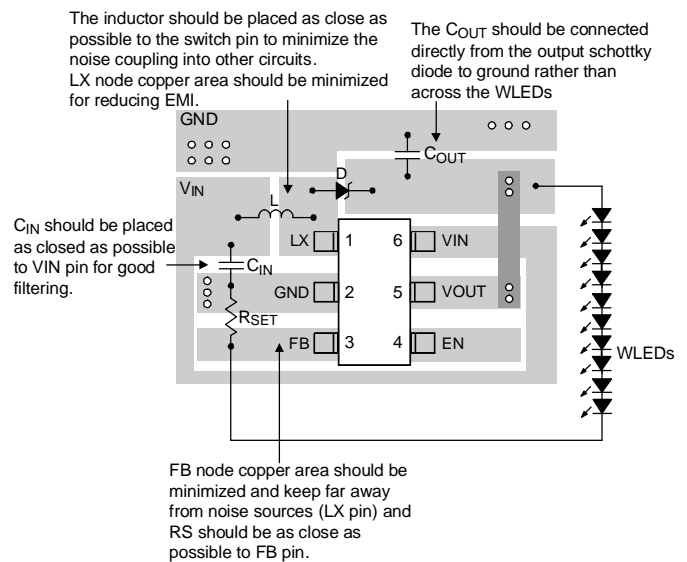
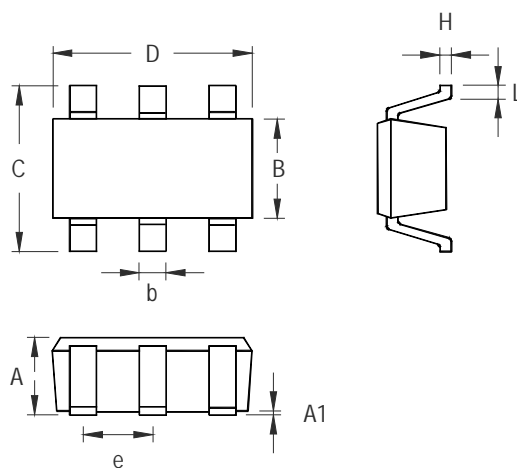

Figure 8. The Layout Consideration of the RT9293

Outline Dimension



Symbol	Dimensions In Millimeters		Dimensions In Inches	
	Min	Max	Min	Max
A	0.700	1.000	0.028	0.039
A1	0.000	0.100	0.000	0.004
B	1.397	1.803	0.055	0.071
b	0.300	0.559	0.012	0.022
C	2.591	3.000	0.102	0.118
D	2.692	3.099	0.106	0.122
e	0.838	1.041	0.033	0.041
H	0.080	0.254	0.003	0.010
L	0.300	0.610	0.012	0.024

TSOT-23-6 Surface Mount Package

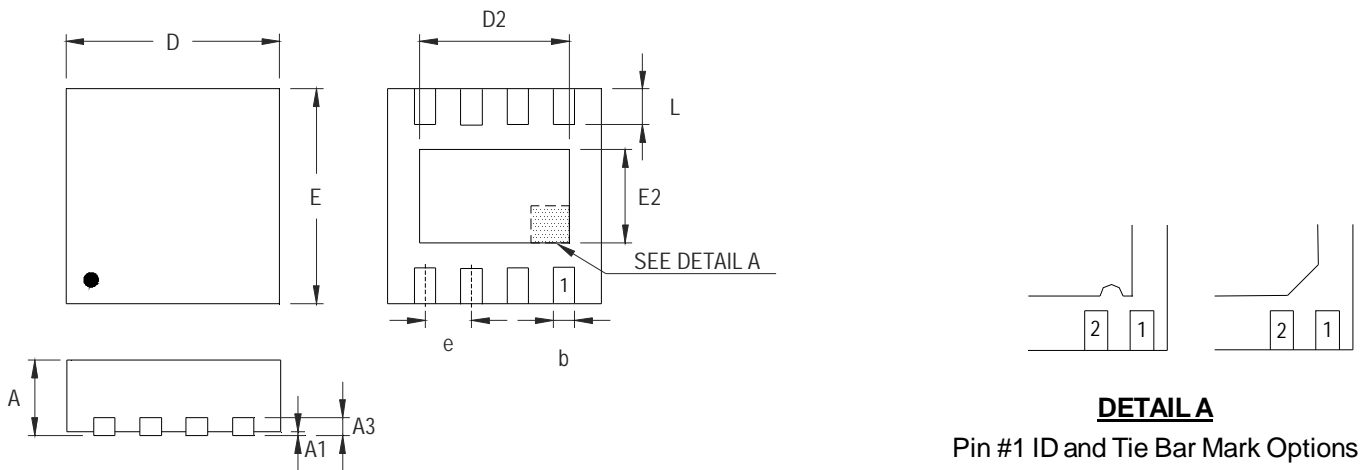

Note : The configuration of the Pin #1 identifier is optional, but must be located within the zone indicated.

Symbol	Dimensions In Millimeters		Dimensions In Inches	
	Min	Max	Min	Max
A	0.700	0.800	0.028	0.031
A1	0.000	0.050	0.000	0.002
A3	0.175	0.250	0.007	0.010
b	0.200	0.300	0.008	0.012
D	1.950	2.050	0.077	0.081
D2	1.000	1.250	0.039	0.049
E	1.950	2.050	0.077	0.081
E2	0.400	0.650	0.016	0.026
e	0.500		0.020	
L	0.300	0.400	0.012	0.016

W-Type 8L DFN 2x2 Package

Richtek Technology Corporation

Headquarter
5F, No. 20, Taiyuen Street, Chupei City
Hsinchu, Taiwan, R.O.C.
Tel: (8863)5526789 Fax: (8863)5526611

Richtek Technology Corporation

Taipei Office (Marketing)
8F, No. 137, Lane 235, Paochiao Road, Hsintien City
Taipei County, Taiwan, R.O.C.
Tel: (8862)89191466 Fax: (8862)89191465
Email: marketing@richtek.com

Information that is provided by Richtek Technology Corporation is believed to be accurate and reliable. Richtek reserves the right to make any change in circuit design, specification or other related things if necessary without notice at any time. No third party intellectual property infringement of the applications should be guaranteed by users when integrating Richtek products into any application. No legal responsibility for any said applications is assumed by Richtek.