

isc Silicon NPN Darlington Power Transistor

2SD1022

DESCRIPTION

- Collector-Emitter Sustaining Voltage-
: $V_{CEO(SUS)} = 100V(\text{Min})$
- High DC Current Gain
: $h_{FE} = 1500(\text{Min}) @ I_C = 3A$
- Low Saturation Voltage

APPLICATIONS

- Designed for general purpose amplifier applications.

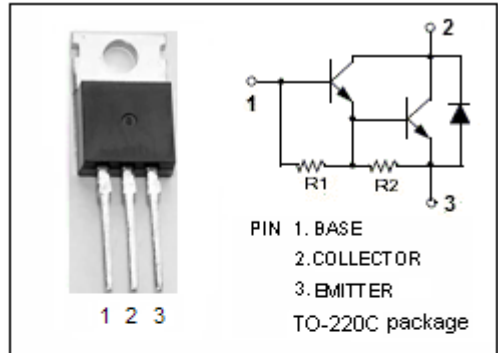

ABSOLUTE MAXIMUM RATINGS($T_a=25^\circ\text{C}$)

SYMBOL	PARAMETER	VALUE	UNIT
V_{CBO}	Collector-Base Voltage	100	V
V_{CEO}	Collector-Emitter Voltage	100	V
V_{EBO}	Emitter-Base Voltage	7	V
I_C	Collector Current-Continuous	5	A
I_{CP}	Collector Current-Peak	8	A
I_B	Base Current-Continuous	0.5	A
I_{BM}	Base Current-Peak	1	A
P_C	Collector Power Dissipation @ $T_C=25^\circ\text{C}$	30	W
T_J	Junction Temperature	150	$^\circ\text{C}$
T_{stg}	Storage Temperature Range	-55~150	$^\circ\text{C}$

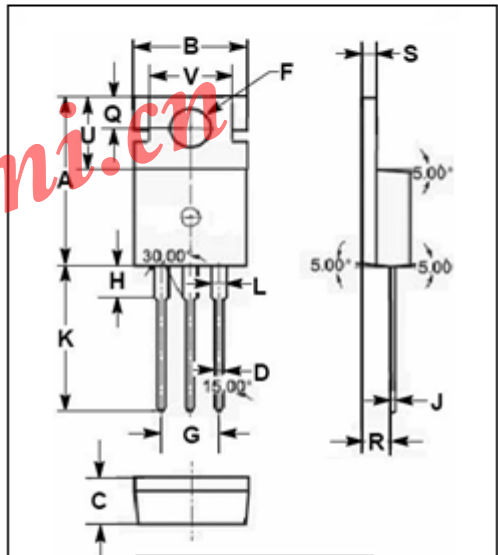

DIM	mm	
	MIN	MAX
A	15.70	15.90
B	9.90	10.10
C	4.20	4.40
D	0.70	0.90
F	3.40	3.60
G	4.98	5.18
H	2.70	2.90
J	0.44	0.46
K	13.20	13.40
L	1.10	1.30
Q	2.70	2.90
R	2.50	2.70
S	1.29	1.31
U	6.45	6.65
V	8.66	8.86

THERMAL CHARACTERISTICS

SYMBOL	PARAMETER	MAX	UNIT
$R_{th\ j-c}$	Thermal Resistance, Junction to Case	4.17	$^\circ\text{C/W}$

isc Silicon NPN Darlington Power Transistor**2SD1022****ELECTRICAL CHARACTERISTICS** $T_C=25^\circ\text{C}$ unless otherwise specified

SYMBOL	PARAMETER	CONDITIONS	MIN	TYP.	MAX	UNIT
$V_{CE(sat)}$	Collector-Emitter Saturation Voltage	$I_C=3\text{A}; I_B=3\text{mA}$			1.5	V
$V_{BE(sat)}$	Base-Emitter Saturation Voltage	$I_C=3\text{A}; I_B=3\text{mA}$			2.0	V
I_{CBO}	Collector Cutoff Current	$V_{CB}=100\text{V}; I_E=0$			0.1	mA
I_{CEO}	Collector Cutoff Current	$V_{CE}=100\text{V}; I_B=0$			0.1	mA
I_{EBO}	Emitter Cutoff Current	$V_{EB}=7\text{V}; I_C=0$			5	mA
h_{FE}	DC Current Gain	$I_C=3\text{A}; V_{CE}=3\text{V}$	1500		30000	
f_T	Current-Gain—Bandwidth Product	$I_C=0.5\text{A}; V_{CE}=10\text{V}$		20		MHz

Switching times

t_{on}	Turn-on Time	$I_C=5\text{A}, I_{B1}=-I_{B2}=5\text{mA}$ $R_L=5\ \Omega; V_{BB2}=4\text{V}$			2.0	μs
t_{stg}	Storage Time				5.0	μs
t_f	Fall Time				3.0	μs