

## PAS302BCA-32 CMOS VGA DIGITAL IMAGE SENSOR

### General Description

The PAS302BCA-32 is a highly integrated CMOS active-pixel image sensor that has a VGA resolution of 644H x 484V. The PAS302BCA-32 outputs 10-bit RGB raw data through a parallel data bus and is available in 32-pin LCC package.

The PAS302BCA-32 can be programmed to set the exposure time for different luminance condition via I<sup>2</sup>C™ serial control bus. By programming the internal register sets, it can perform on-chip frame rate adjustment, offset correction DAC and programmable gain control.

### Features

- **VGA(644 x 484 pixels) resolution, ~1/4" Lens**
- **Bayer-RGB color filter array**
- **Output format: 10-bit parallel RGB raw data**
- **On-chip 10-bit pipelined A/D converter**
- **On-chip programmable gain amplifier**
  - 4-bit color gain amplifier (x1~x2)
  - 4-bit global gain amplifier (x1~x2)
- **Digital gain stage**
- **Continuous variable frame time(1/2sec~1/30sec)**
- **Continuous variable exposure time**
- **I<sup>2</sup>C™ Interface**
- **Support flash light timing**
- **Single 2.5V / 3.3V supply voltage**
- **< 15mA(~30 fps) power dissipation**
- **2μA power dissipation when power down mode**
- **Window-Of-Interest (WOI)**
- **Sub-sampling**
- **Defect compensation**

### Key Specification

<b>Supply Voltage</b>	2.5V ~ 3.3V
<b>Resolution</b>	644(H) x 484(V)
<b>Array diagonal</b>	4.5mm (~1/4"Optic)
<b>Pixel Size</b>	5.6μm x 5.6μm
<b>Chief Ray Angle</b>	12° ~ 14°
<b>Frame rate</b>	~30 fps
<b>System clock</b>	Up to 48 MHz
<b>Pixel clock</b>	Up to 12MHz
<b>Sensitivity</b>	1.88 V/Lux-Sec
<b>Color filter</b>	RGB Bayer Pattern
<b>Exposure Time</b>	~ Frame time to Line time
<b>Scan Mode</b>	Progressive
<b>S/N Ratio</b>	> 45 dB
<b>Package</b>	32-pin LCC

Note1: Only two decoupling capacitors needed  
 Note2: Good sensitivity compared to competitors

## 1. Pin Assignment

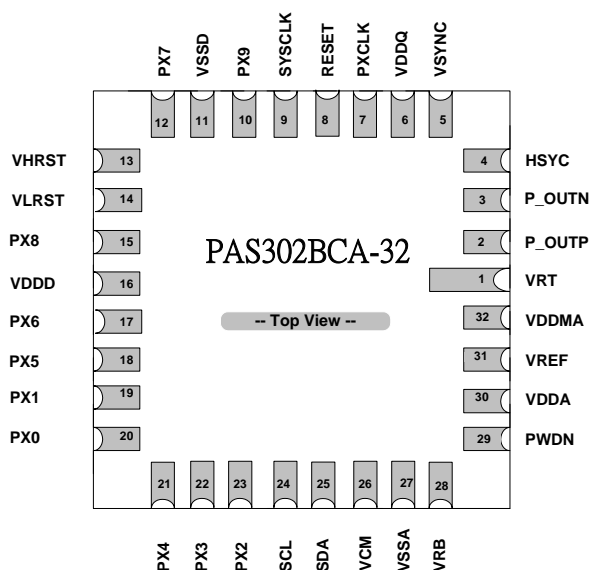

Figure 1.1. PAS302BCA-32 pin assignment

Pin No.	Name	Type	Description
1	VRT	BYPASS	Voltage reference top
2	P_OUTP	BYPASS	Analog test output P
3	P_OUTN	BYPASS	Analog test output N
4	HSYNC	OUT	Horizontal synchronization signal.
5	VSYNC	OUT	Vertical synchronization signal.
6	VDDQ	PWR	Digital VDD, 2.5V to 3.3V.
7	PXCLK	OUT	Pixel clock output.
8	RESET	IN	Resets all registers to their default values (chip reset when high)
9	SYSCLK	IN	Master clock input.
10	PX9	OUT	Digital data out.
11	VSSD	GND	Digital ground.
12	PX7	OUT	Digital data out.
13	VHRST	BYPASS	Sensor reset power
14	VLRST	BYPASS	Sensor reset power
15	PX8	OUT	Digital data out.
16	VDDD	PWR	Digital VDD,
17	PX6	OUT	Digital data out.
18	PX5	OUT	Digital data out.
19	PX1	OUT	Digital data out.
20	PX0	OUT	Digital data out.
21	PX4	OUT	Digital data out.
22	PX3	OUT	Digital data out.
23	PX2	OUT	Digital data out.

24	SCL	IN	I <sup>2</sup> C™ clock.
25	SDA	I/O	I <sup>2</sup> C™ data. Internal pull high resistor is 10KΩ.
26	VCM	BYPASS	Voltage common mode
27	VSSA	GND	Analog ground.
28	VRB	BYPASS	Voltage reference bottom
29	PWDN	IN	Power Down (chip power down when high)
30	VDDA	PWR	Analog VDD,
31	VREF	IN	Internal voltage reference.
32	VDDMA	PWR	Analog VDD, 2.5V to 3.3V.

## 2. Block Diagram

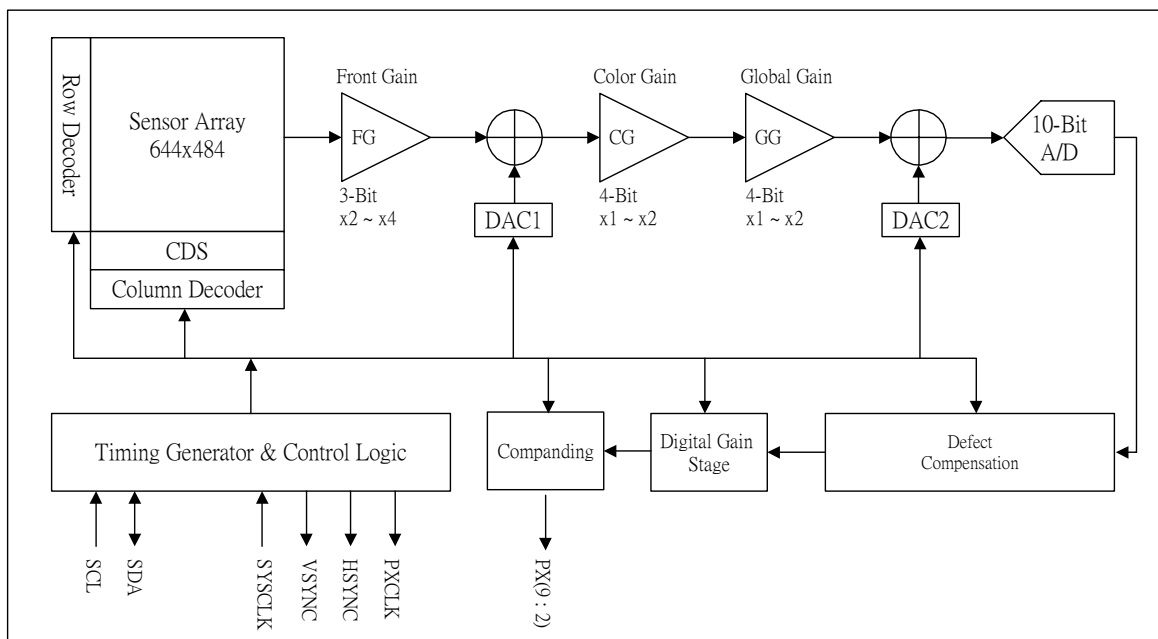

Figure 2.1. PAS302BCA-32 sensor block diagram

The PAS302BCA-32 is a 1/4" CMOS imaging sensor with 644x488 physical pixels. The active region of sensor array is 644x484 as shown in Fig. 2.1. The sensor array is covered with Bayer pattern color filters and micro-lens. The first pixel location <0,0> is programmable in 2 direction (X and Y) and the default value is at the left-down side of sensor array.

After a programmable exposure time, the signals of image are sampled first with CDS (Correlated Double Sampling) block to improve S/N ratio and reduce fixed pattern noise.

Three analog gain stages are implemented before signals are transferred to 10-Bit ADC. The front gain stage (FG) can be programmed to fit the saturation level of sensor to the full-range input of ADC. The programmable color gain stage (CG) is used to balance the luminance response difference between B, G and R color. The global gain stage (GG) is programmed to adapt the gain to the image luminance.

After three gain stages, the signals will be digitized by the on-chip 10-Bit ADC. After the image data have been digitized, further adjustment to the signal can be applied before the data is output to next stage.

### 3. Function Description

#### 3.1. Defect Compensation

The Defect Compensation block can detect the possible defect pixel and replace it with average output of like-colored pixels from near side of defect pixel. There is no limitation capability of defect pixel number. This function can be programmed to enable/disable by user.

#### 3.2. Companding Curves

The companding function which means compressing and expanding is used to simulate the gamma curve and do non-linear transformation before the data is output. There are 4 curves selected by setting Register Compand\_Sel as shown in Fig. 3.1. This function can be programmed to enable/disable by user.

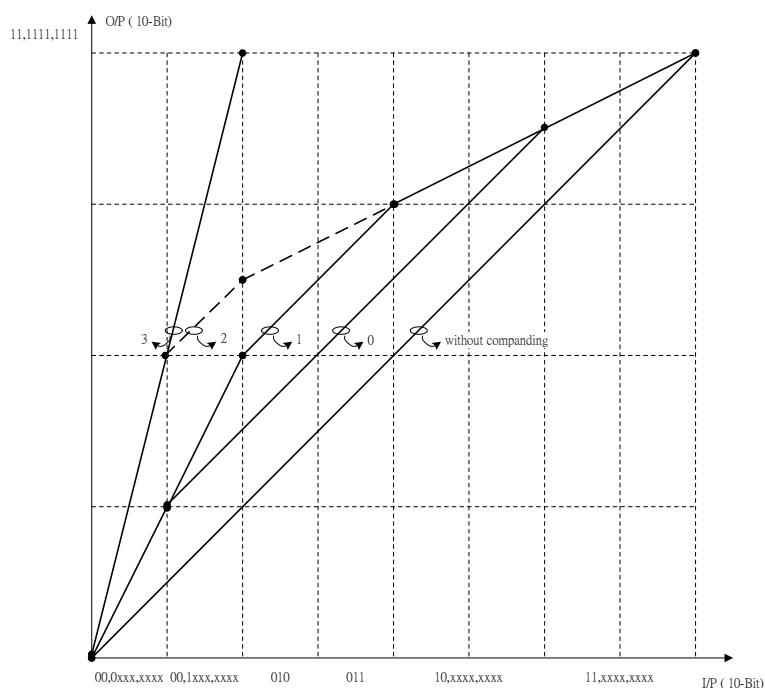

Figure 3.1 Companding curves program by Compand\_EnH and Compand\_Sel.

#### 3.3. Power Down Mode

The PAS302BCA-32 can be powered down by setting register “Sw\_PwrDn” = 1 or by enable Pwdn pin. The register value will sustain in the power down mode. PAS302BCA-32 supports 2 power down modes:

- Software power down : Set register “Sw\_PwrDn” = 1 to power down all the internal block except I<sup>2</sup>C<sup>TM</sup>.
- Hardware power down : Pull Pwdn pin to high to power down the chip. The chip will go into standby mode.

#### 3.4. Reset Mode

The PAS302BCA-32 can be reseted by setting register “Sw\_Reset” = 1 or by enable Reset pin. PAS302BCA-32 supports 2 reset modes:

- Software reset : Set register “Sw\_Reset” = 1 to reset all the I<sup>2</sup>C<sup>TM</sup> registers.
- Hardware reset : Pull Reset pin to high to reset the full chip.

## 4. Output Format

### 4.1. Physical Sensor Array

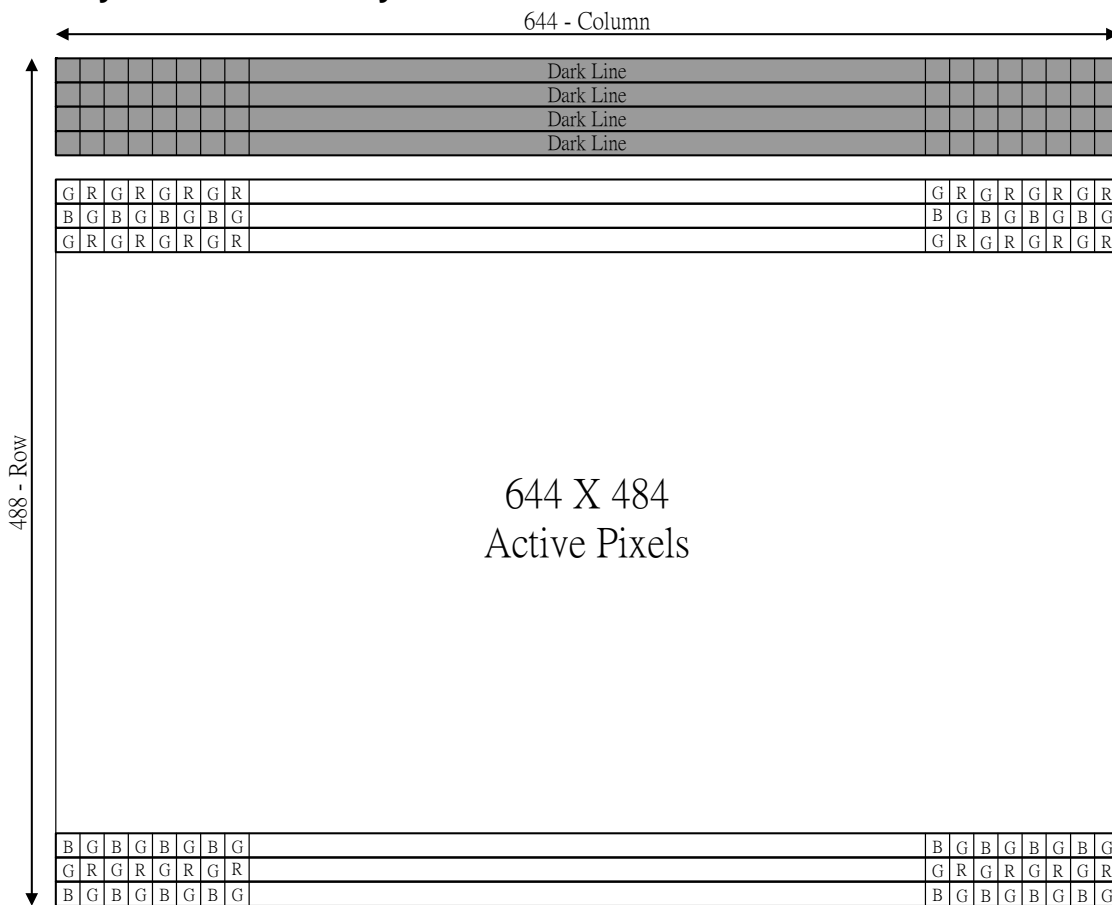

Figure 4.1 Physical Sensor Array

### 4.2. Output Timing

VGA mode ( 644 x 488 ) pixel readout:

H\_Start[9:0] = 0, V\_Start[8:0] = 0, H\_Size[9:0] = 643, V\_Size[8:0] = 487,  
 Nov\_By2[7:0] = 87,

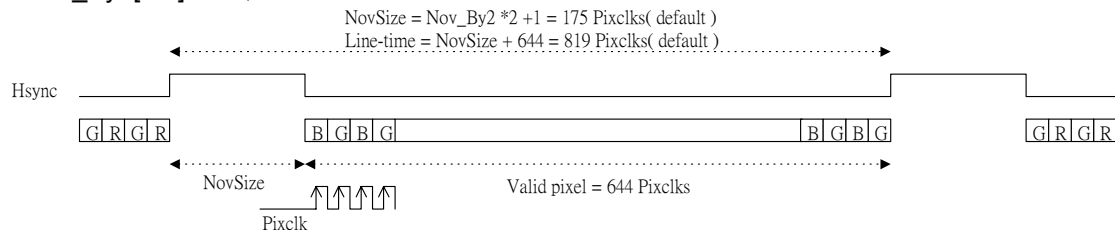

Figure 4.2 Inter-line timing ( default )

If Mask\_Dark[3] = 0,

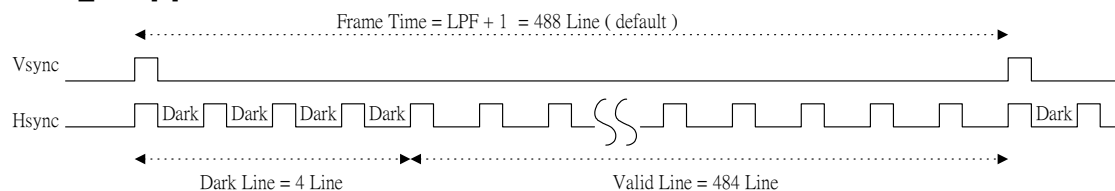

Figure 4.3 Inter-frame timing (LPF default setting = 487, Mask\_Dark[3] =0)

If Mask\_Dark[3] = 1,

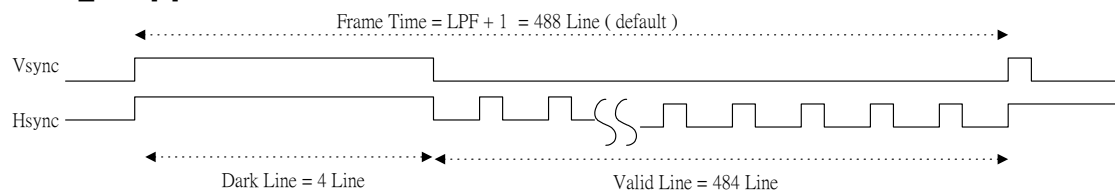

Figure 4.4 Inter-frame timing (LPF default setting = 487, Mask\_Dark[3] =1)

### 4.3. Hardware Windowing

Users are allowed to define window size as well as window location in PAS302BCA-32, Window size can range from 20x14 to 644x484. The location of window can be anywhere in the sensor array. Window location and size is defined by register H\_Start, V\_Start, H\_Size and V\_Size; the H\_Start defines the starting column while V\_Start defines the starting row of the window; the H\_Size define the column width of the window and V\_Start define the row depth of the window.

### 4.4. Sub-sampling

PAS302BCA-32 can be programmed to output image in QVGA and QQVGA size by setting Registers Skip\_Digital or Skip\_Analog. In QVGA sub-sampling mode, both vertical and horizontal pixels are sub-sampling at 1/2, while in QQVGA sub-sampling mode, both vertical and horizontal pixels are sub-sampling at 1/4. The maximum sub-sampling rate is 1/16.

## 5. I<sup>2</sup>C™ Bus

PAS302BCA-32 supports I<sup>2</sup>C™ bus transfer protocol and acts as slave device. The 7 bits unique slave address is 1000000 and the bus supports receiving / transmitting speed up to 400kHz.

### 5.1. I<sup>2</sup>C™ Bus Overview

There are only two lines SDA (serial data) and SCL (serial clock) carry information between the devices which are connected by I<sup>2</sup>C™ bus. Normally both SDA and SCL lines are open collector structure and pulled high by external pull-up resistors.

Only the master can initiate a transfer (start), generate clock signals, and terminate a transfer (stop).

Start Condition :

A high to low transition of the SDA line while SCL is high defines a start condition.

Stop Condition :

A low to high transition of the SDA line while SCL is high defines a stop condition.

Valid Data:

The data on the SDA line must be stable during the high period of the SCL clock. Within each byte, MSB is always transferred first. Read/write control bit is the LSB of the first byte.

Both the master and slave can transmit and receive data from the bus.

Acknowledge :

The receiving device should pull down the SDA line during high period of the SCL clock line when a byte was transferred completely by transmitter. When in the case of that a master received data from a slave, the master does not generate an acknowledgment on the last byte to indicate the end of a master read cycle.

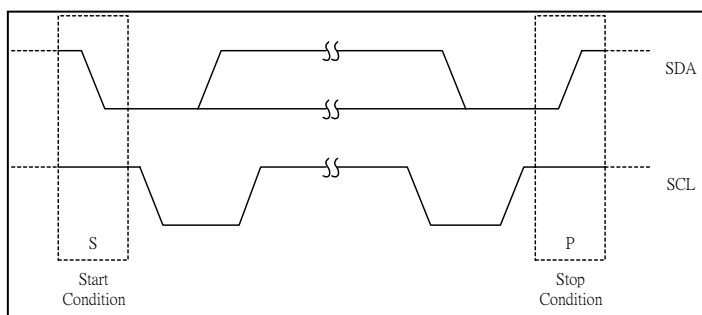

Figure 5-1: Start and Stop Conditions

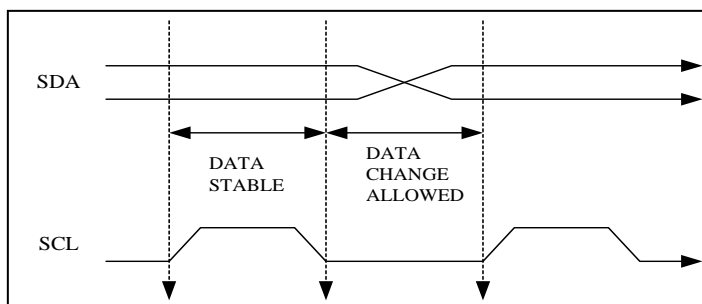

Figure 5-2: Valid Data



## 5.2. Data Transfer Format

### 5.2.1. Master transmits data to slave (write cycle)

- S : Start
- A : Acknowledge by slave
- P : Stop
- RW : The LSB of 1st byte to decide whether current cycle is read or write cycle.  
If RW=1 that means read cycle, if RW=0 that means write cycle..
- SUBADDRESS : The address values of PAS302BCA-32 internal control registers  
(Please refer to PAS302BCA-32 register description)

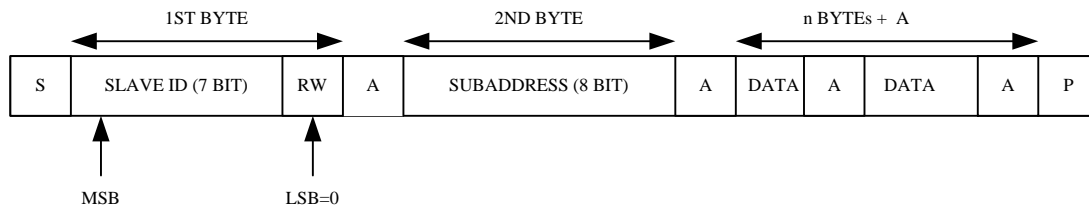

During the write cycle, the master generates start condition and then places the 1st byte data that combined slave address (7 bits) with a read/write control bit on SDA line. After slave(PAS302BCA-32) issues acknowledgment, the master places 2nd byte (sub-address) data on SDA line. And then following the slave's( PAS302BCA-32) acknowledgment, the master places the 8 bits data on SDA line and transmit to PAS302BCA-32 control register (address was assigned by 2nd byte). After PAS302BCA-32 issue acknowledgment, the master can generate a stop condition to end this write cycle. In the condition of multi-byte write, the PAS302BCA-32 sub-address will be increased automatically after each DATA byte has been transferred. The Data and A cycles are repeated until last byte write. Every control registers value inside PAS302BCA-32 can be programming via this way. (Please refer to Figure 5.3.)

### 5.2.2. Slave transmits data to master (read cycle)

- The sub-address was assigned by previous write cycle
- The sub-address is automatically increased after each byte read
- Am : Acknowledged by master
- Note there is no acknowledgment from master after last byte read

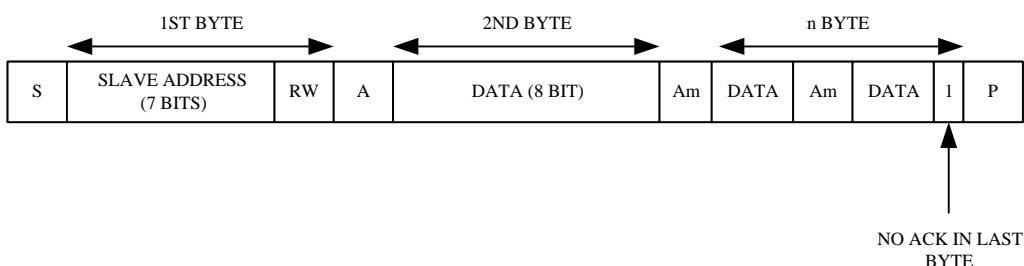

During read cycle, the master generates start condition and then place the 1st byte data that combine slave address (7 bits) with a read/write control bit to SDA line. After slave issue acknowledgment, 8 bits DATA was placed on SDA line by PAS302BCA-32. The 8 bit data was read from PAS302BCA-32 internal control register that address was assigned by previous write cycle. Following the master acknowledgment, the PAS302BCA-32 place the next 8 bits data (address is increased automatically) on SDA line and then transfer to master serially. The DATA and Am cycles are repeated until the last byte read. After last byte read, Am is no longer

generated by master but instead of keeping SDA line as high. The slave (PAS302BCA-32) must releases SDA line back to master to generate STOP condition. (Please refer to Figure 5.3.)

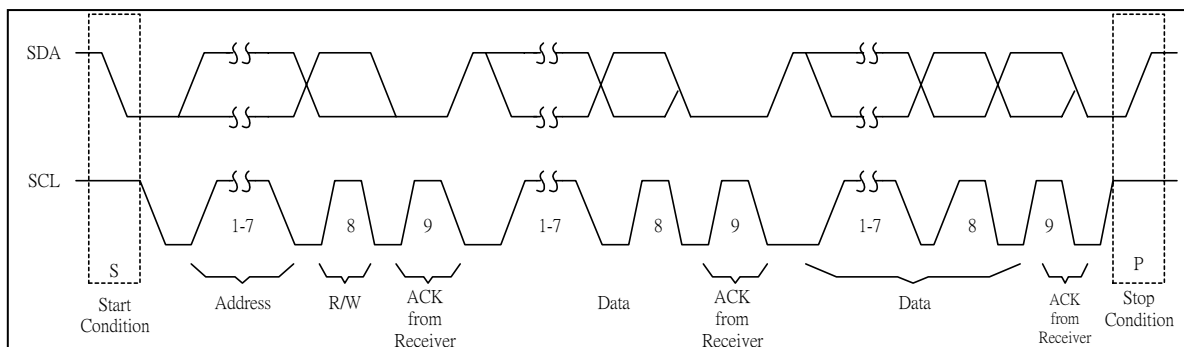
**Figure 5.3 Data Transfer Format**

### 5.3. I<sup>2</sup>C™ Bus Timing

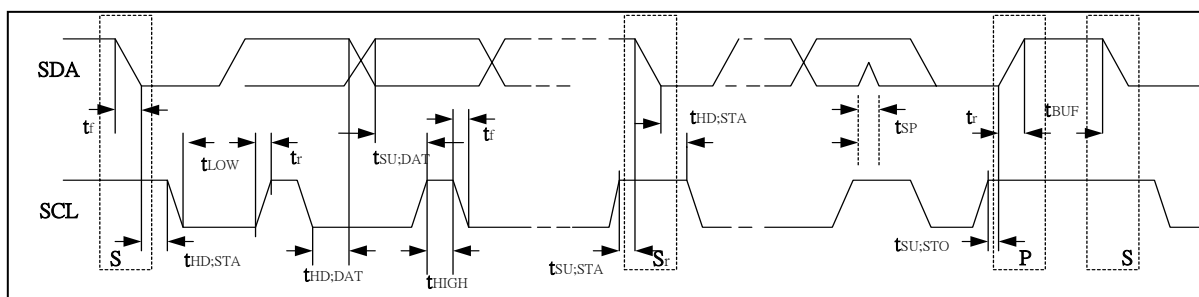
**Figure 5.4 I<sup>2</sup>C™ Bus Timing**

### 5.4. I<sup>2</sup>C™ Bus Timing Specification

PARAMETER	SYMBOL	STANDARD-MODE		UNIT
		MIN.	MAX.	
SCL clock frequency	$f_{scl}$	10	400	kHz
Hold time (repeated) START condition. After this period, the first clock pulse is generated.	$t_{HD:STA}$	4.0	-	$\mu s$
Low period of the SCL clock	$t_{LOW}$	4.7	-	$\mu s$
HIGH period of the SCL clock	$t_{HIGH}$	0.75	-	$\mu s$
Set-up time for a repeated START condition	$t_{SU:STA}$	4.7	-	$\mu s$
Data hold time. For I <sup>2</sup> C™ bus device	$t_{HD:DAT}$	0	3.45	$\mu s$
Data set-up time	$t_{SU:DAT}$	250	-	ns
Rise time of both SDA and SCL signals	$t_r$	30	N.D.(Note)	ns
Fall time of both SDA and SCL signals	$t_f$	30	N.D. (Note)	ns
Set-up time for STOP condition	$t_{SU:STO}$	4.0	-	$\mu s$
Bus free time between a STOP and START	$t_{BUF}$	4.7	-	$\mu s$
Capacitive load for each bus line	$C_b$	1	15	pF
Noise margin at LOW level for each connected device (including hysteresis)	$V_{nL}$	0.1 VDD	-	V

Noise margin at HIGH level for each connected device (including hysteresis)	$V_{nH}$	0.2 VDD	-	V
---	----------	---------	---	---

Note: It depends on the "high" period time of SCL.

## 6. Electrical Characteristics

### Absolute Maximum Ratings

<b>Ambient Storage Temperature</b>		-40°C ~ +125°C
<b>Supply Voltages</b> ( with respect to Ground )	<b>V<sub>DDD</sub></b>	3V
	<b>V<sub>DDA</sub></b>	3V
	<b>V<sub>DDMA</sub></b>	4V
	<b>V<sub>DDQ</sub></b>	4V
<b>All Input / Output Voltages ( with respect to Ground )</b>		-0.3V to V <sub>DDQ</sub> + 1V
<b>Lead Temperature, Surface-mount process</b>		+230°C
<b>ESD Rating, Human Body model</b>		2000V

### DC Electrical Characteristics ( VDD = 2.5V ± 4% , Ta =0°C ~ 70°C )

Symbol	Parameter	Min.	Typ.	Max.	Unit
<b>Type :PWR</b>					
V <sub>DDA</sub>	DC Supply voltage – Analog	2.4	2.5	2.6	V
V <sub>DDD</sub>	DC Supply voltage – Digital	2.4	2.5	2.6	V
V <sub>DDQ</sub>	DC Supply voltage – I/O	2.4	-	3.3	V
V <sub>DDMA</sub>	DC Supply voltage – Analog	2.4	-	3.3	V
I <sub>DD</sub>	Operating Current		15		mA
I <sub>PWDN</sub>	Power Down current		2		µA
<b>Type :IN &amp; I/O Reset and SYSCLK</b>					
V <sub>IH</sub>	Input voltage HIGH	0.7 x V <sub>DDQ</sub>			V
V <sub>IL</sub>	Input voltage LOW			0.3 x V <sub>DDQ</sub>	V
C <sub>IN</sub>	Input capacitor			10	pF
<b>Type : OUT &amp; I/O for PXD0:7, PXCK, H/VSYNC &amp; SDA, load 10pf, 1.2kΩ,2.5volts</b>					
V <sub>OH</sub>	Output voltage HIGH	0.9 x V <sub>DDQ</sub>			V
V <sub>OL</sub>	Output voltage LOW			0.1 x V <sub>DDQ</sub>	V

### AC Operating Condition

Symbol	Parameter	Min.	Typ.	Max.	Unit
SYSCLK	Master clock frequency			48	MHz
PXCK	Pixel clock output frequency			12	MHz

### Sensor Characteristics

Parameter		Typ.	Unit	Note
Sensitivity		1.88	V/ Lux-Sec	
Signal to Noise Ratio		> 45	dB	
Dynamic Range		60	dB	
Temperature Range	Operation	-10 ~ 70	°C	
	Stable Image	0 ~ 50		

### 7. Reference Circuit Schematic

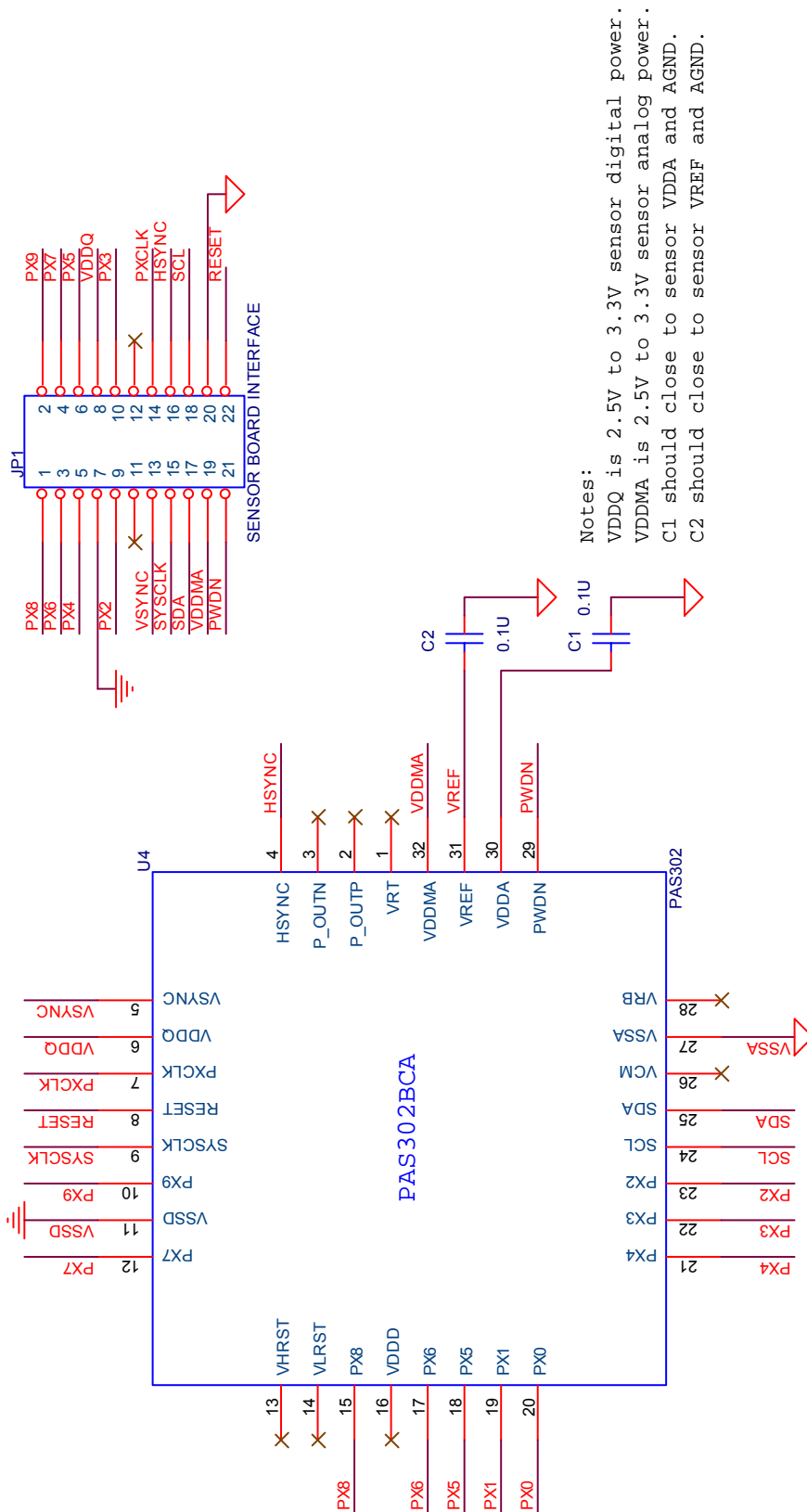

### 8. Package Specification

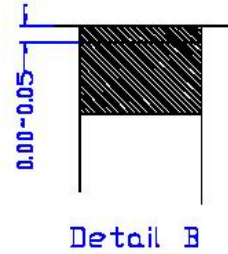
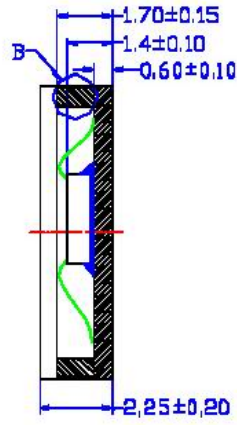
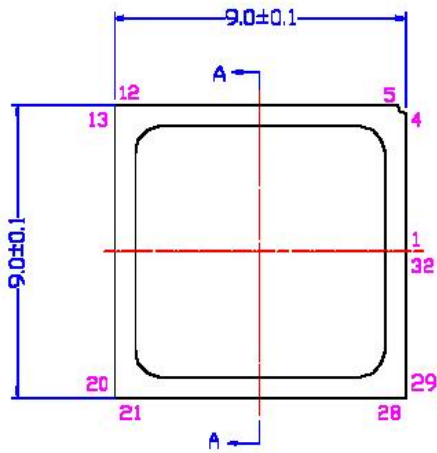

A-A Section

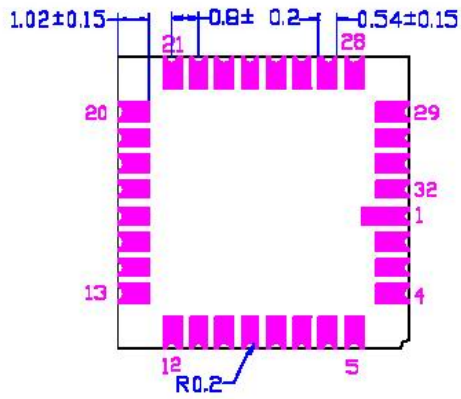

Unit:mm

9. Recommended Lens and Holder

