



REVISION HISTORY

<u>Revision</u>	<u>Description</u>	<u>Issue Date</u>
Rev. 1.0	Initial Issue	Jul.25.2004
Rev. 1.1	Revised Icc	Aug.13.2004
Rev. 1.2	Deleted L grade Added SL grade Added I_{SB1}/I_{DR} values when $T_A = 25^\circ C$ and $T_A = 40^\circ C$ Revised FEATURES & ORDERING INFORMATION Lead free and green package available to Green package available Added packing type in ORDERING INFORMATION Revised V_{TERM} to V_{T1} and V_{T2} Deleted T_{SOLDER} in ABSOLUTE MAXIMUM RATINGS	Mar.30.2009

FEATURES

- Fast access time : 35/55/70ns
- Low power consumption:
 - Operating current : 12/10/7mA (TYP.)
 - Standby current : 1 μ A (TYP.) LL-version
 - 0.8 μ A (TYP.) SL-version
- Single 2.7V ~ 3.6V power supply
- All inputs and outputs TTL compatible
- Fully static operation
- Tri-state output
- Data retention voltage : 1.5V (MIN.)
- **Green package available**
- Package : 32-pin 450 mil SOP
 - 32-pin 600 mil P-DIP
 - 32-pin 8mm x 20mm TSOP-I
 - 32-pin 8mm x 13.4mm STSOP
 - 36-ball 6mm x 8mm TFBGA

GENERAL DESCRIPTION

The LY62L1024 is a 1,048,576-bit low power CMOS static random access memory organized as 131,072 words by 8 bits. It is fabricated using very high performance, high reliability CMOS technology. Its standby current is stable within the range of operating temperature.

The LY62L1024 is well designed for very low power system applications, and particularly well suited for battery back-up nonvolatile memory application.

The LY62L1024 operates from a single power supply of 2.7V ~ 3.6V and all inputs and outputs are fully TTL compatible

PRODUCT FAMILY

Product Family	Operating Temperature	Vcc Range	Speed	Power Dissipation	
				Standby(I _{SB1} ,TYP.)	Operating(I _{CC} ,TYP.)
LY62L1024	0 ~ 70°C	2.7 ~ 3.6V	35/55/70ns	1 μ A(LL)/0.8 μ A(SL)	12/10/7mA
LY62L1024(E)	-20 ~ 80°C	2.7 ~ 3.6V	35/55/70ns	1 μ A(LL)/0.8 μ A(SL)	12/10/7mA
LY62L1024(I)	-40 ~ 85°C	2.7 ~ 3.6V	35/55/70ns	1 μ A(LL)/0.8 μ A(SL)	12/10/7mA

FUNCTIONAL BLOCK DIAGRAM

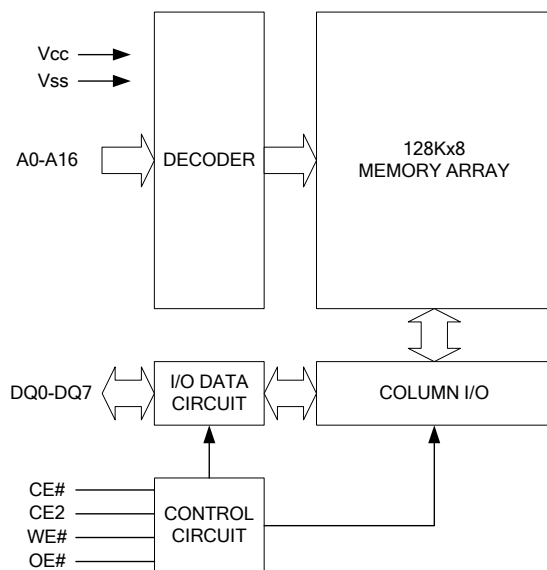

PIN DESCRIPTION

SYMBOL	DESCRIPTION
A0 - A16	Address Inputs
DQ0 - DQ7	Data Inputs/Outputs
CE#, CE2	Chip Enable Inputs
WE#	Write Enable Input
OE#	Output Enable Input
Vcc	Power Supply
Vss	Ground
NC	No Connection



PIN CONFIGURATION

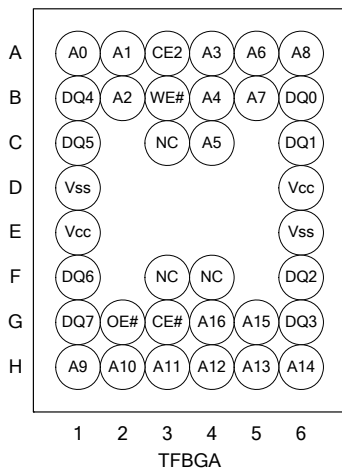
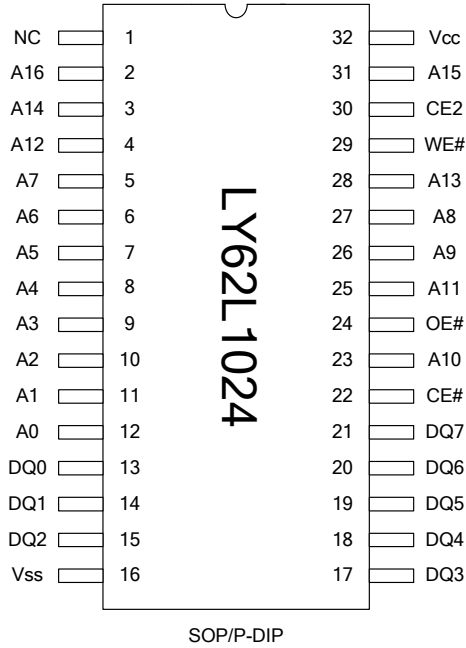



ABSOLUTE MAXIMUM RATINGS*

PARAMETER	SYMBOL	RATING	UNIT
Voltage on Vcc relative to Vss	V _{T1}	-0.5 to 4.6	V
Voltage on any other pin relative to Vss	V _{T2}	-0.5 to V _{cc} +0.5	V
Operating Temperature	T _A	0 to 70(C grade)	°C
		-20 to 80(E grade)	
		-40 to 85(I grade)	
Storage Temperature	T _{STG}	-65 to 150	°C
Power Dissipation	P _D	1	W
DC Output Current	I _{OUT}	50	mA

*Stresses greater than those listed under "Absolute Maximum Ratings" may cause permanent damage to the device. This is a stress rating only and functional operation of the device or any other conditions above those indicated in the operational sections of this specification is not implied. Exposure to the absolute maximum rating conditions for extended period may affect device reliability.

TRUTH TABLE

MODE	CE#	CE2	OE#	WE#	I/O OPERATION	SUPPLY CURRENT
Standby	H	X	X	X	High-Z	I _{SB} , I _{SB1}
	X	L	X	X	High-Z	I _{SB} , I _{SB1}
Output Disable	L	H	H	H	High-Z	I _{cc} , I _{cc1}
Read	L	H	L	H	D _{OUT}	I _{cc} , I _{cc1}
Write	L	H	X	L	D _{IN}	I _{cc} , I _{cc1}

Note: H = V_{IH}, L = V_{IL}, X = Don't care.



DC ELECTRICAL CHARACTERISTICS

PARAMETER	SYMBOL	TEST CONDITION	MIN.	TYP. ⁴	MAX.	UNIT		
Supply Voltage	V _{CC}		2.7	3.0	3.6	V		
Input High Voltage	V _{IH} ¹		2.2	-	V _{CC} +0.3	V		
Input Low Voltage	V _{IL} ²		-0.2	-	0.6	V		
Input Leakage Current	I _{LI}	V _{CC} ≥ V _{IN} ≥ V _{SS}	-1	-	1	μA		
Output Leakage Current	I _{LO}	V _{CC} ≥ V _{OUT} ≥ V _{SS} , Output Disabled	-1	-	1	μA		
Output High Voltage	V _{OH}	I _{OH} = -1mA	2.2	2.7	-	V		
Output Low Voltage	V _{OL}	I _{OL} = 2mA	-	-	0.4	V		
Average Operating Power supply Current	I _{CC}	Cycle time = Min. CE# = V _{IL} and CE2 = V _{IH} , I _{I/O} = 0mA Other pins at V _{IL} or V _{IH}	-35	-	12	35	mA	
			-55	-	10	30	mA	
			-70	-	7	25	mA	
	I _{CC1}	Cycle time = 1μs CE# = 0.2V and CE2 ≥ V _{CC} -0.2V, I _{I/O} = 0mA Other pins at 0.2V or V _{CC} - 0.2V	-	1	5	mA		
Standby Power Supply Current	I _{SB}	CE# = V _{IH} or CE2 = V _{IL} , other pins at V _{IL} or V _{IH}	-	0.3	0.5	mA		
	I _{SB1}	CE# ≥ V _{CC} -0.2V or CE2 ≤ 0.2V Others at 0.2V or V _{CC} - 0.2V	LL	-	1	10	μA	
			LLE/LLI	-	1	20	μA	
			SL ⁺⁵	25°C	-	0.8	2	μA
			SLE ⁺⁵		-	0.8	2	μA
			SLI ⁺⁵	40°C	-	1	2	μA
			SL		-	0.8	5	μA
SLE/SLI	-	0.8	8	μA				

Notes:

- V_{IH}(max) = V_{CC} + 3.0V for pulse width less than 10ns.
- V_{IL}(min) = V_{SS} - 3.0V for pulse width less than 10ns.
- Over/Undershoot specifications are characterized, not 100% tested.
- Typical values are included for reference only and are not guaranteed or tested.
Typical values are measured at V_{CC} = V_{CC}(TYP.) and T_A = 25°C
- This parameter is measured at V_{CC} = 3.0V

**CAPACITANCE (T_A = 25°C, f = 1.0MHz)**

PARAMETER	SYMBOL	MIN.	MAX	UNIT
Input Capacitance	C _{IN}	-	6	pF
Input/Output Capacitance	C _{I/O}	-	8	pF

Note : These parameters are guaranteed by device characterization, but not production tested.

AC TEST CONDITIONS

Input Pulse Levels	0.2V to V _{CC} - 0.2V
Input Rise and Fall Times	3ns
Input and Output Timing Reference Levels	1.5V
Output Load	C _L = 30pF + 1TTL, I _{OH} /I _{OL} = -1mA/2mA

AC ELECTRICAL CHARACTERISTICS**(1) READ CYCLE**

PARAMETER	SYM.	LY62L1024-35		LY62L1024-55		LY62L1024-70		UNIT
		MIN.	MAX.	MIN.	MAX.	MIN.	MAX.	
Read Cycle Time	t _{RC}	35	-	55	-	70	-	ns
Address Access Time	t _{AA}	-	35	-	55	-	70	ns
Chip Enable Access Time	t _{ACE}	-	35	-	55	-	70	ns
Output Enable Access Time	t _{OE}	-	25	-	30	-	35	ns
Chip Enable to Output in Low-Z	t _{CLZ} *	10	-	10	-	10	-	ns
Output Enable to Output in Low-Z	t _{OLZ} *	5	-	5	-	5	-	ns
Chip Disable to Output in High-Z	t _{CHZ} *	-	15	-	20	-	25	ns
Output Disable to Output in High-Z	t _{OHZ} *	-	15	-	20	-	25	ns
Output Hold from Address Change	t _{OH}	10	-	10	-	10	-	ns

(2) WRITE CYCLE

PARAMETER	SYM.	LY62L1024-35		LY62L1024-55		LY62L1024-70		UNIT
		MIN.	MAX.	MIN.	MAX.	MIN.	MAX.	
Write Cycle Time	t _{WC}	35	-	55	-	70	-	ns
Address Valid to End of Write	t _{AW}	30	-	50	-	60	-	ns
Chip Enable to End of Write	t _{CW}	30	-	50	-	60	-	ns
Address Set-up Time	t _{AS}	0	-	0	-	0	-	ns
Write Pulse Width	t _{WP}	25	-	45	-	55	-	ns
Write Recovery Time	t _{WR}	0	-	0	-	0	-	ns
Data to Write Time Overlap	t _{DW}	20	-	25	-	30	-	ns
Data Hold from End of Write Time	t _{DH}	0	-	0	-	0	-	ns
Output Active from End of Write	t _{OW} *	5	-	5	-	5	-	ns
Write to Output in High-Z	t _{WHZ} *	-	15	-	20	-	25	ns

*These parameters are guaranteed by device characterization, but not production tested.



TIMING WAVEFORMS

READ CYCLE 1 (Address Controlled) (1,2)

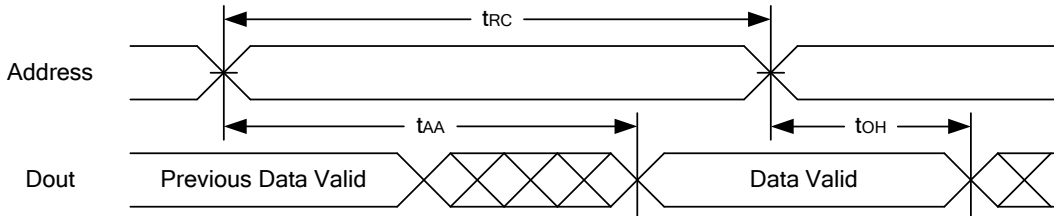

READ CYCLE 2 (CE# and CE2 and OE# Controlled) (1,3,4,5)

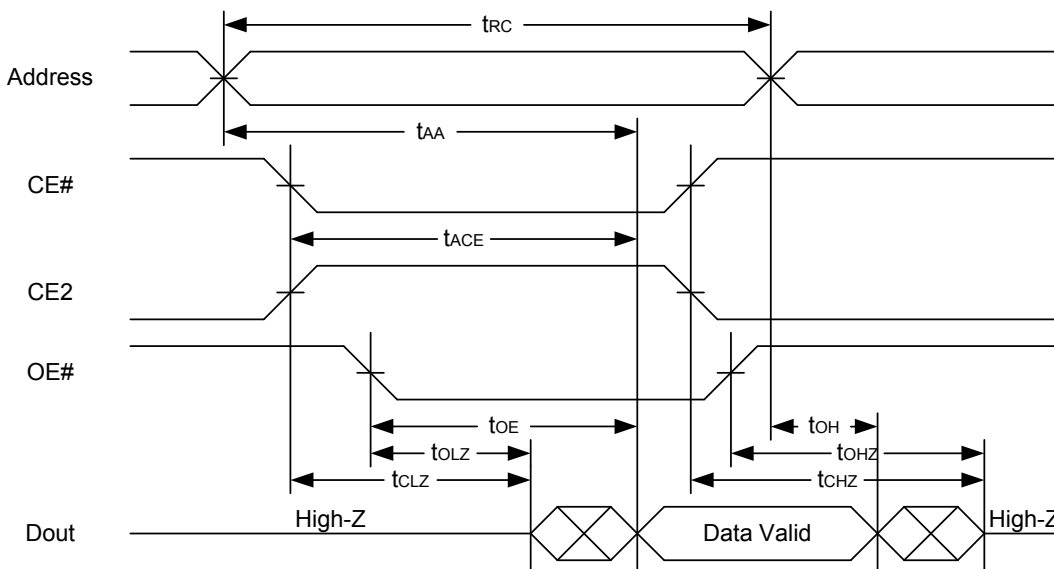

Notes :

1. WE# is high for read cycle.
2. Device is continuously selected OE# = low, CE# = low, CE2 = high.
3. Address must be valid prior to or coincident with CE# = low, CE2 = high; otherwise tAA is the limiting parameter.
4. tCLZ, tOLZ, tCHZ and tOHZ are specified with CL = 5pF. Transition is measured ±500mV from steady state.
5. At any given temperature and voltage condition, tCHZ is less than tCLZ, tOHZ is less than tOLZ.

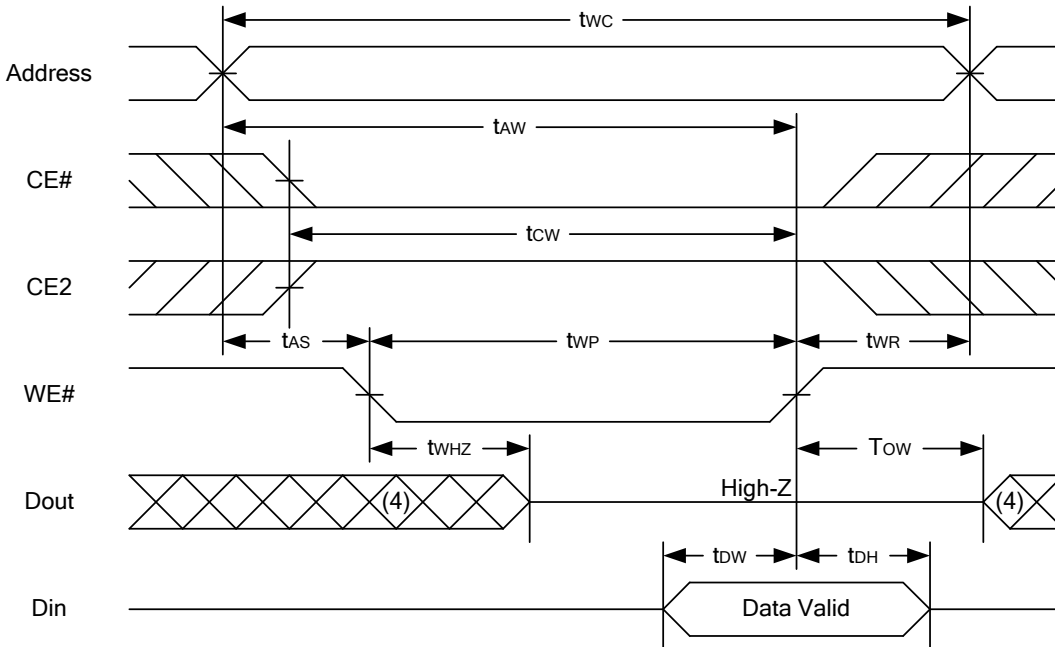
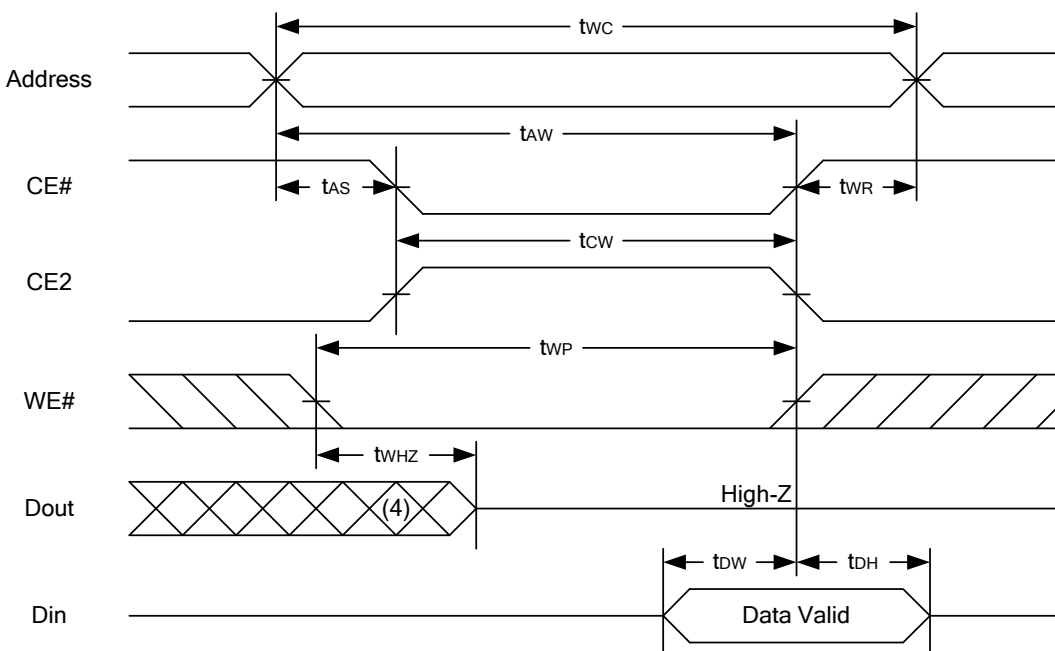
WRITE CYCLE 1 (WE# Controlled) (1,2,3,5,6)

WRITE CYCLE 2 (CE# and CE2 Controlled) (1,2,5,6)

Notes :

1. WE#, CE# must be high or CE2 must be low during all address transitions.
2. A write occurs during the overlap of a low CE#, high CE2, low WE#.
3. During a WE#-controlled write cycle with OE# low, t_{wp} must be greater than $t_{whz} + t_{dw}$ to allow the drivers to turn off and data to be placed on the bus.
4. During this period, I/O pins are in the output state, and input signals must not be applied.
5. If the CE# low transition and CE2 high transition occurs simultaneously with or after WE# low transition, the outputs remain in a high impedance state.
6. t_{ow} and t_{whz} are specified with $C_L = 5pF$. Transition is measured $\pm 500mV$ from steady state.



DATA RETENTION CHARACTERISTICS

PARAMETER	SYMBOL	TEST CONDITION	MIN.	TYP.	MAX.	UNIT		
V _{CC} for Data Retention	V _{DR}	CE# ≥ V _{CC} - 0.2V or CE2 ≤ 0.2V	1.5	-	3.6	V		
Data Retention Current	I _{DR}	V _{CC} = 1.5V CE# ≥ V _{CC} - 0.2V or CE2 ≤ 0.2V Other pins at 0.2V or V _{CC} -0.2V	LL	-	0.5	5	μA	
			LLE/LLI	-	0.5	10	μA	
			SL	25°C	-	0.4	2	μA
			SLE	40°C	-	0.5	2	μA
			SLI		SL	-	0.4	5
			SLE/SLI	-	0.4	8	μA	
Chip Disable to Data Retention Time	t _{CDR}	See Data Retention Waveforms (below)	0	-	-	ns		
Recovery Time	t _R		t _{RC} *	-	-	ns		

t_{RC}* = Read Cycle Time

DATA RETENTION WAVEFORM

Low V_{CC} Data Retention Waveform (1) (CE# controlled)

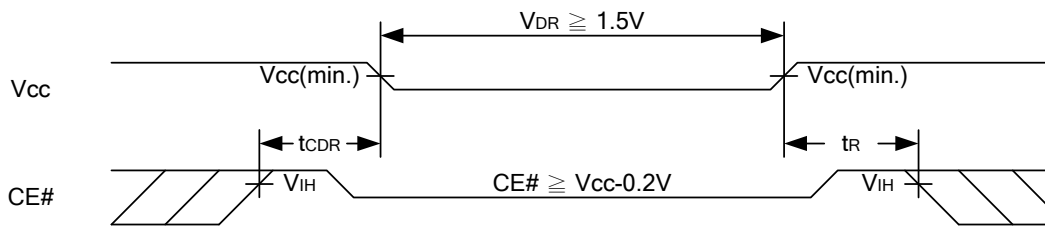

Low V_{CC} Data Retention Waveform (2) (CE2 controlled)

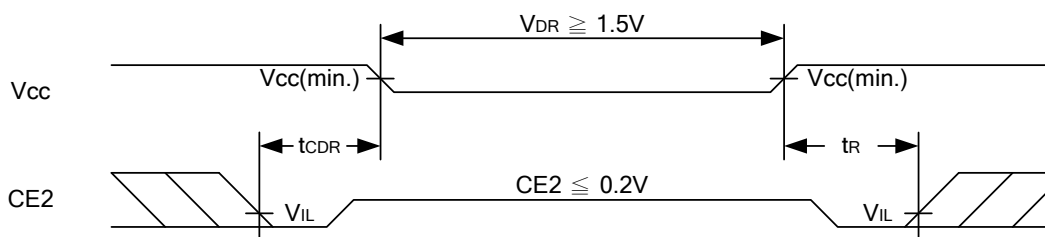



PACKAGE OUTLINE DIMENSION

32 pin 450 mil SOP Package Outline Dimension

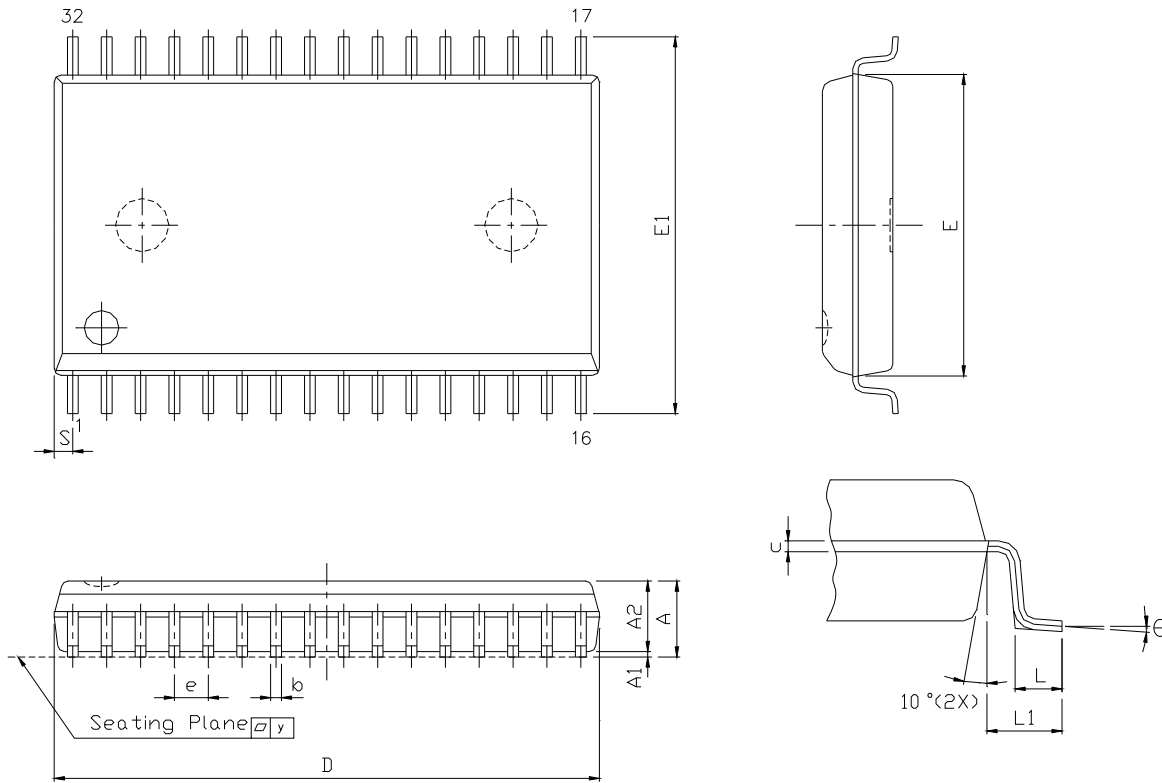

SYM.	UNIT	INCH.(BASE)	MM(REF)
	A		0.118 (MAX)
A1		0.004(MIN)	0.102(MIN)
A2		0.111(MAX)	2.82(MAX)
b		0.016(TYP)	0.406(TYP)
c		0.008(TYP)	0.203(TYP)
D		0.817(MAX)	20.75(MAX)
E		0.445 ±0.005	11.303 ±0.127
E1		0.555 ±0.012	14.097 ±0.305
e		0.050(TYP)	1.270(TYP)
L		0.0347 ±0.008	0.881 ±0.203
L1		0.055 ±0.008	1.397 ±0.203
S		0.026(MAX)	0.660 (MAX)
y		0.004(MAX)	0.101(MAX)
∅		0° -10°	0° -10°



32 pin 600 mil P-DIP Package Outline Dimension

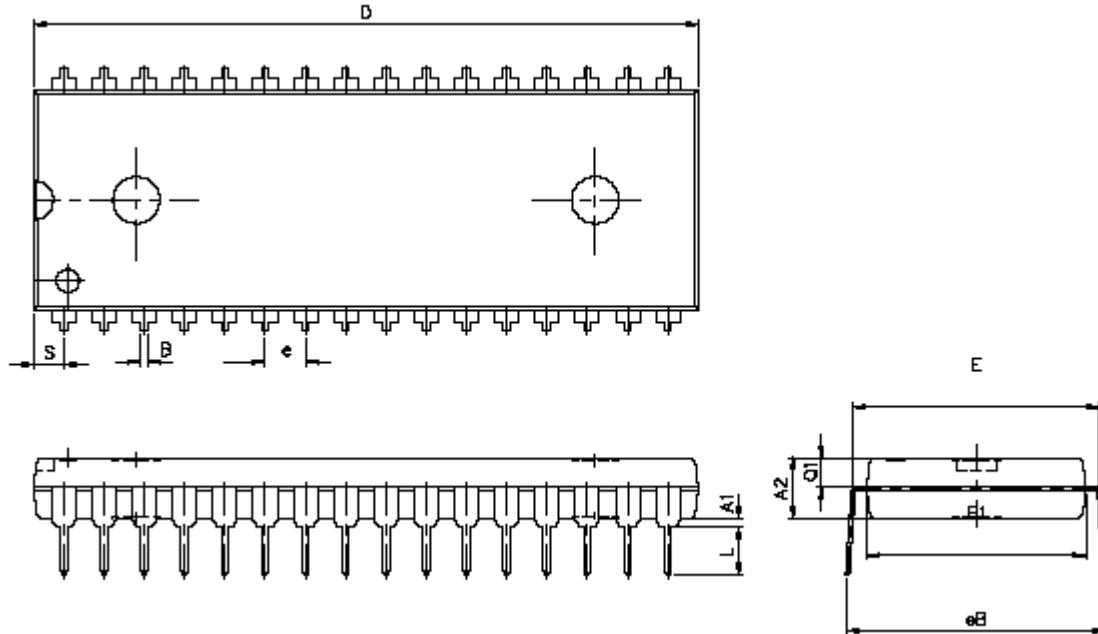

SYM.	UNIT	INCH(BASE)	MM(REF)
A1		0.001 (MIN)	0.254 (MIN)
A2		0.150 ± 0.005	3.810 ± 0.127
B		0.018 ± 0.005	0.457 ± 0.127
D		1.650 ± 0.005	41.910 ± 0.127
E		0.600 ± 0.010	15.240 ± 0.254
E1		0.544 ± 0.004	13.818 ± 0.102
e		0.100 (TYP)	2.540 (TYP)
eB		0.640 ± 0.020	16.256 ± 0.508.
L		0.130 ± 0.010	3.302 ± 0.254
S		0.075 ± 0.010	1.905 ± 0.254
Q1		0.070 ± 0.005	1.778 ± 0.127

Note : D/E1/S dimension do not include mold flash.



32 pin 8mm x 20mm TSOP-I Package Outline Dimension

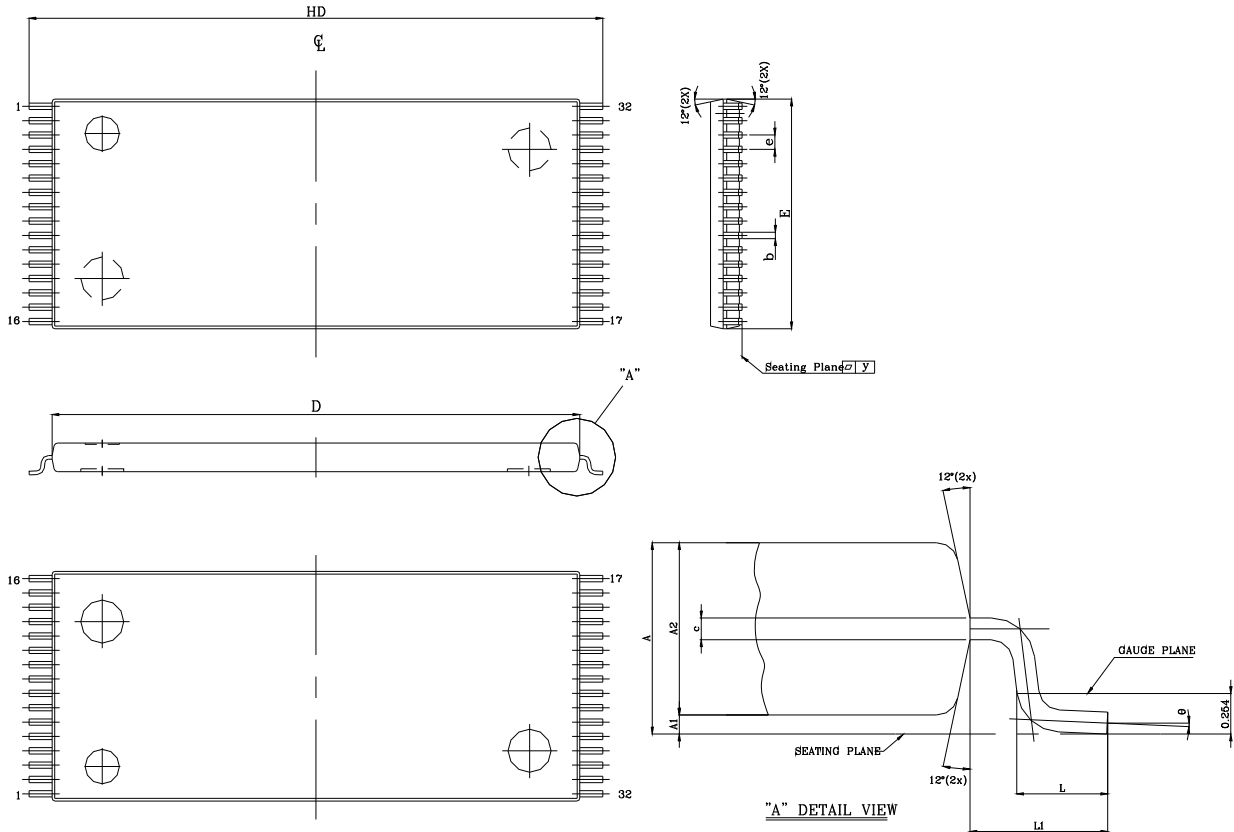

SYM. \ UNIT	INCH(BASE)	MM(REF)
A	0.047 (MAX)	1.20 (MAX)
A1	0.004 ±0.002	0.10 ±0.05
A2	0.039 ±0.002	1.00 ±0.05
b	0.008 + 0.002 - 0.001	0.20 + 0.05 - 0.03
c	0.005 (TYP)	0.127 (TYP)
D	0.724 ±0.004	18.40 ±0.10
E	0.315 ±0.004	8.00 ±0.10
e	0.020 (TYP)	0.50 (TYP)
HD	0.787 ±0.008	20.00 ±0.20
L	0.0197 ±0.004	0.50 ±0.10
L1	0.0315 ±0.004	0.08 ±0.10
y	0.003 (MAX)	0.076 (MAX)
θ	0° ~ 5°	0° ~ 5°



32 pin 8mm x 13.4mm STSOP Package Outline Dimension

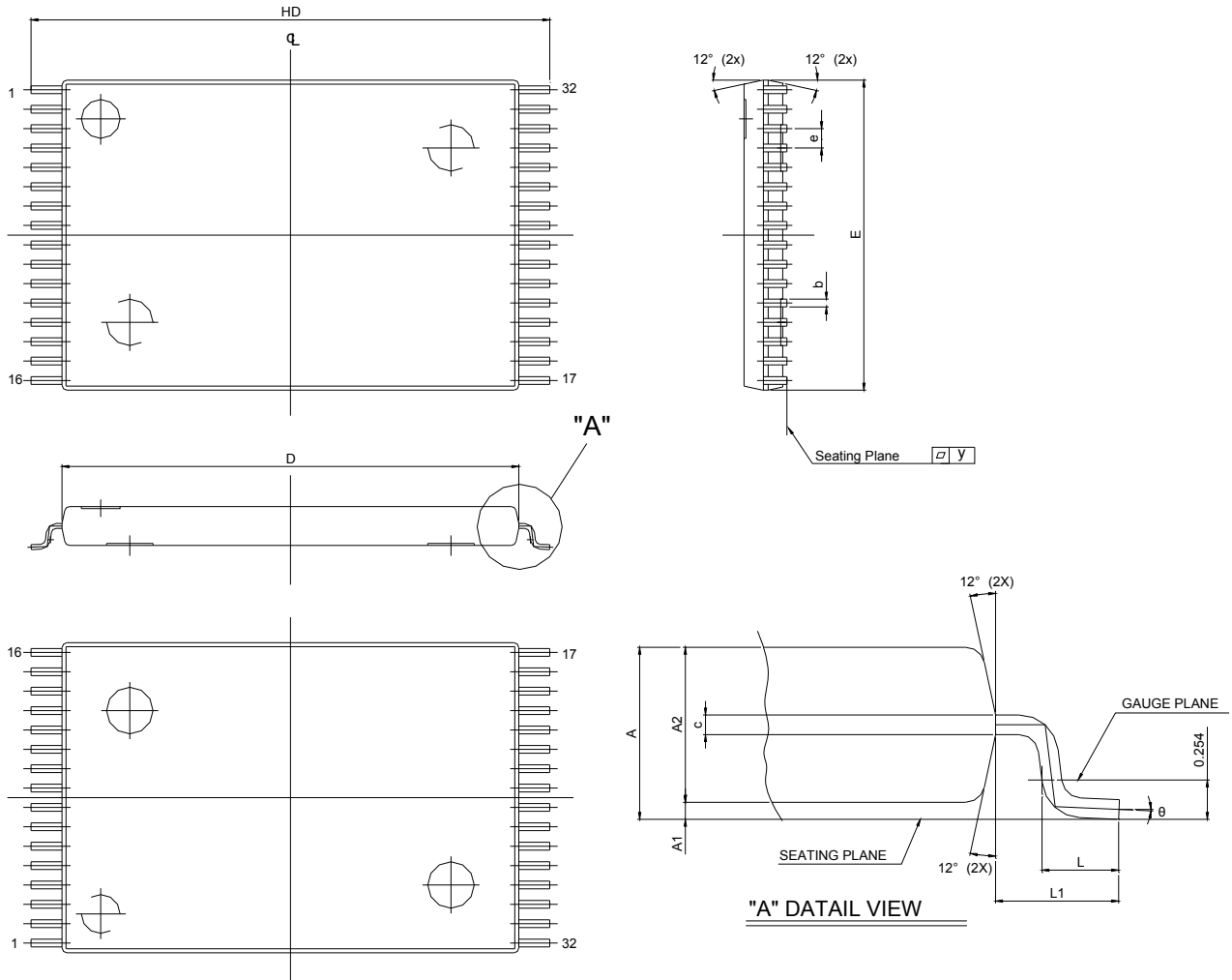

SYM.	UNIT	INCH(BASE)	MM(REF)
A		0.049 (MAX)	1.25 (MAX)
A1		0.005 ±0.002	0.130 ±0.05
A2		0.039 ±0.002	1.00 ±0.05
b		0.008 ±0.01	0.20±0.025
c		0.005 (TYP)	0.127 (TYP)
D		0.465 ±0.004	11.80 ±0.10
E		0.315 ±0.004	8.00 ±0.10
e		0.020 (TYP)	0.50 (TYP)
HD		0.528±0.008	13.40 ±0.20.
L		0.0197 ±0.004	0.50 ±0.10
L1		0.0315 ±0.004	0.8 ±0.10
y		0.003 (MAX)	0.076 (MAX)
Θ		0°~5°	0°~5°

36 ball 6mm x 8mm TFBGA Package Outline Dimension

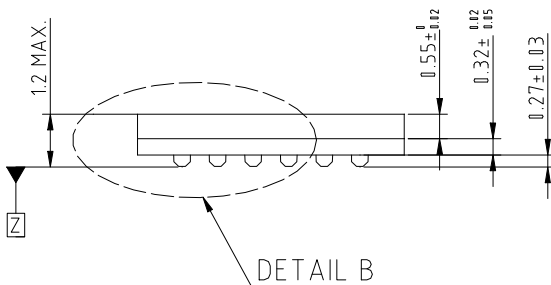
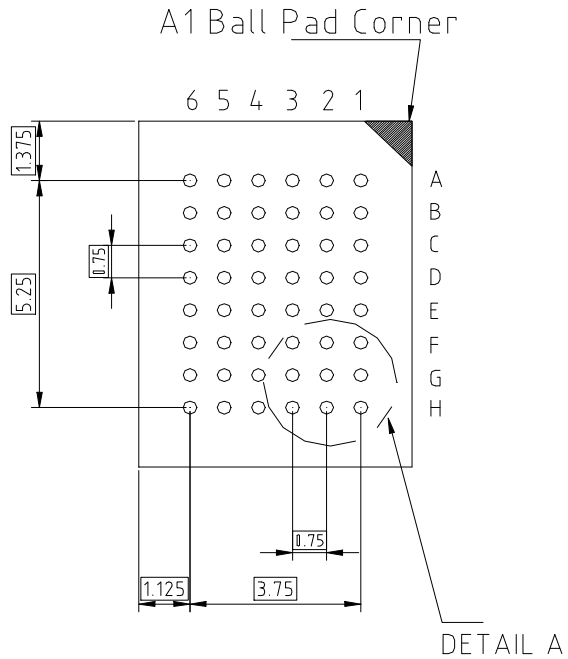
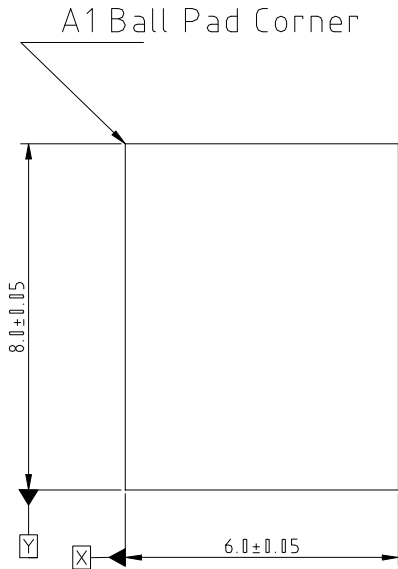

SIDE VIEW

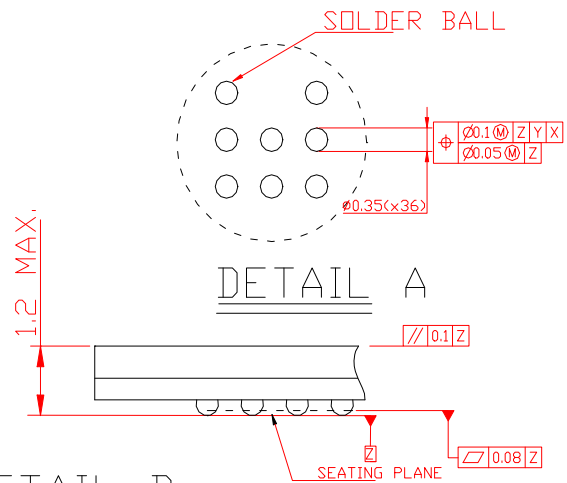

DETAIL B



ORDERING INFORMATION

LY62L1024 U V - WW XX Y Z

Z : Packing Type
Blank : Tube or Tray
T : Tape Reel

Y : Temperature Range
Blank : (Commercial) 0°C ~ 70°C
E : (Extended) -20°C ~ +80°C
I : (Industrial) -40°C ~ +85°C

XX : Power Type
LL : Ultra Low Power
SL : Special Ultra Low Power

WW : Access Time(Speed)

V : Lead Information
L : Green Package

U : Package Type
S : 32-pin 450 mil SOP
P : 32-pin 600 mil P-DIP
L : 32-pin 8 mm x 20 mm TSOP-I
R : 32-pin 8 mm x 13.4 mm STSOP
G : 36-ball 6 mm x 8 mm TFBGA



Lyontek Inc.

LY62L1024

Rev. 1.2

128K X 8 BIT LOW POWER CMOS SRAM

THIS PAGE IS LEFT BLANK INTENTIONALLY.