

Model 5219
Triaxial, 3 Lug Bayonet BNC Style, (F) Bulkhead Mount

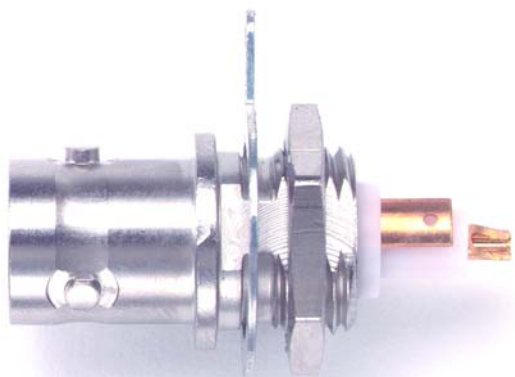

Model 5219
Triaxial, 3 Lug Bayonet BNC Style,
(F) Bulkhead Mount

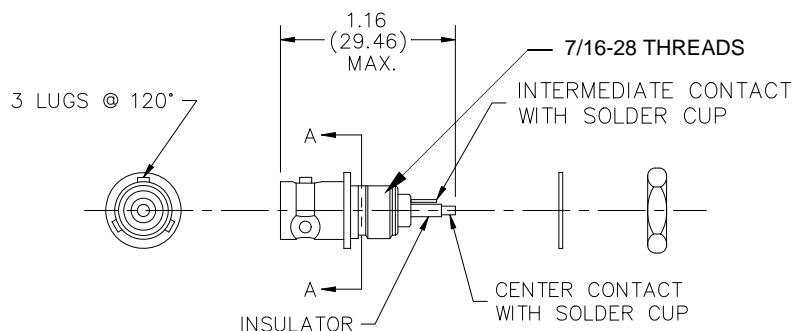

0.05" MAX PANEL THICKNESS

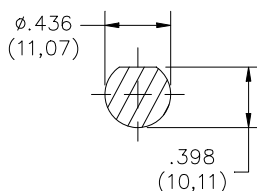

SECTION A-A

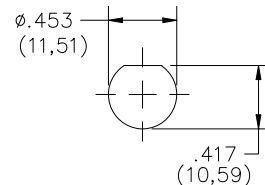

MOUNTING HOLE PATTERN

Materials

Body/Fittings: Brass per QQ-B-626, Alloy 360, 1/2 Hard
Tarnish Resistant

Dielectric: PTFE per MIL-P-19468

Center Contact: Gold Plated Beryllium Copper per QQ-C-530, Cond. HT. & MIL-C-49142.

Marking: "POMONA 5219"

Ratings

Operating Voltage: 500 VRMS

Nominal Impedance: 50 Ohms

Frequency Range: DC to 500 MHZ

Operating Temperature: -65°C to +165°C

Ordering Information

Model: 5219

USA: Sales: 800-490-2361
Technical Support: technicalsupport@pomonatest.com
Fax: 425-446-5844

Europe: 31-(0) 40 2675 150 **International:** 425-446-5500

Where to Buy: www.pomonaelectronics.com

All dimensions are in inches. Tolerances (except noted): .xx = ±.02" (.51 mm), .xxx = ±.005" (.127 mm). All specifications are to the latest revisions. Specifications are subject to change without notice. Registered trademarks are the property of their respective companies.