

**RGC10DH THRU RGC10MH**

● **FEATURES**

- \* Halogen-free type
- \* Lead free product, compliance to RoHs
- \* GPRC (Glass passivated rectifier chip) inside
- \* Glass passivated cavity-free junction
- \* Lead less chip form, no lead damage
- \* Low power loss , High efficiency
- \* High current capability
- \* Plastic package has Underwriters Laboratory Flammability Classification 94V-0

● **APPLICATION**

- \* General purpose rectification
- \* Surge absorption

● **MECHANICAL DATA**

**Case :** Packed with FRP substrate and epoxy underfilled  
**Terminals :** Pure Tin plated (Lead-Free), solderable per MIL-STD-750, Method 2026.  
**Polarity :** Cathode Band, Laser marking  
**Weight :** 0.02 gram

● **PACKING**

- \* 3,000 pieces per 7" (178mm ± 2mm) reel
- \* 4 reels per box
- \* 6 boxes per carton

● **OUTLINE DIMENSIONS**

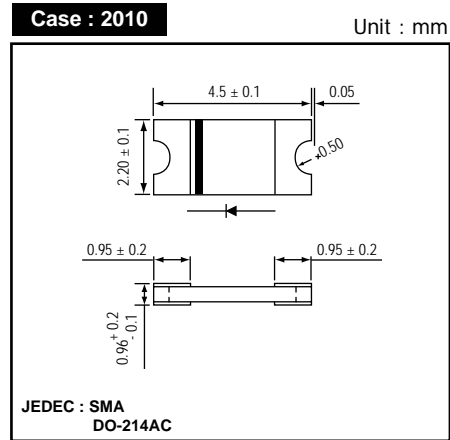

● **MARKING**

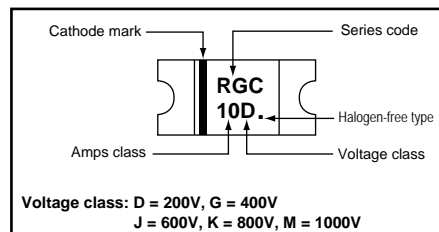

**Absolute Maximum Ratings (Ta = 25 °C)**

ITEM	Symbol	Conditions	RGC10					Unit
			DH	GH	JH	KH	MH	
Repetitive peak reverse voltage	VRRM		200	400	600	800	1000	V
Average forward current	IF(AV)		1.0					A
Peak forward surge current	IFSM	8.3ms single half sine-wave	30					A
Reverse recovery time	Trr	IF = 0.5A, IR = 1.0A, Irr = 0.25A	150	250	300	500		nS
Operating storage temperature Range	Tj,TSTG		-65 to +175					°C

ITEM	Symbol	Conditions	Min.	Typ.	Max.	Unit
Forward voltage	VF	IF = 1.0A	-	1.05	1.30	V
Repetitive peak reverse current	IRRM	VR = Max. VRRM , Ta = 25 °C	-	0.10	5	uA
Junction capacitance	Cj	VR = 4V, f = 1.0 MHz	-	8.2	-	pF
Thermal resistance	Rth(JA)	Junction to ambient (NOTE)	-	61	-	°C/W
	Rth(JL)	Junction to lead (NOTE)	-	7	-	

NOTES : (1) Thermal resistance from junction to ambient and from junction to lead P.C.B. mounted on 0.2 x 0.2" (5.0 x 5.0mm) copper pad areas.  
 (2) Preliminary draft.

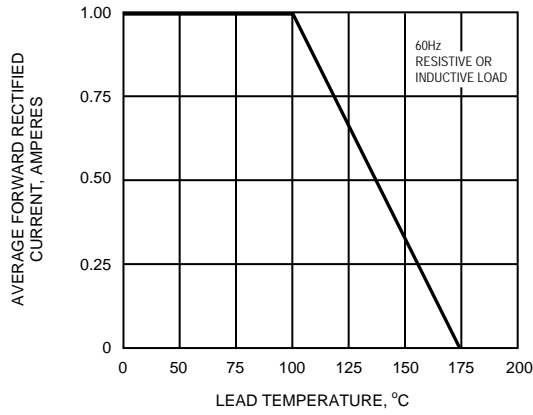
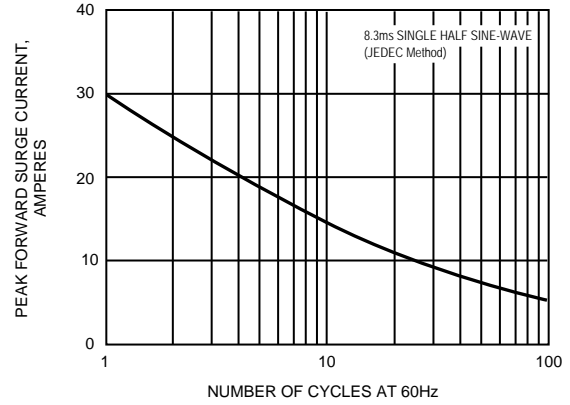
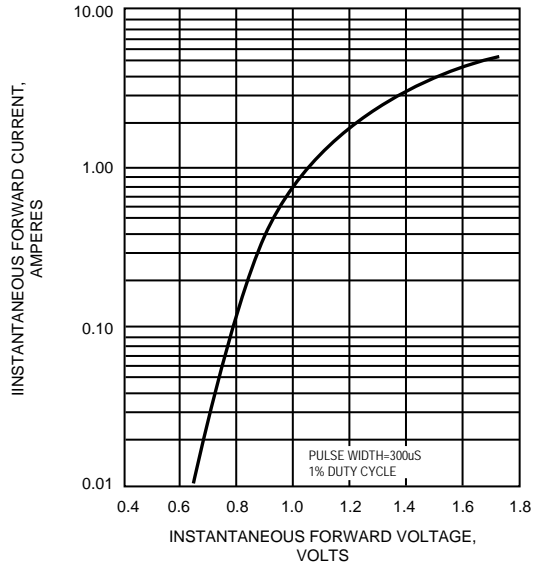
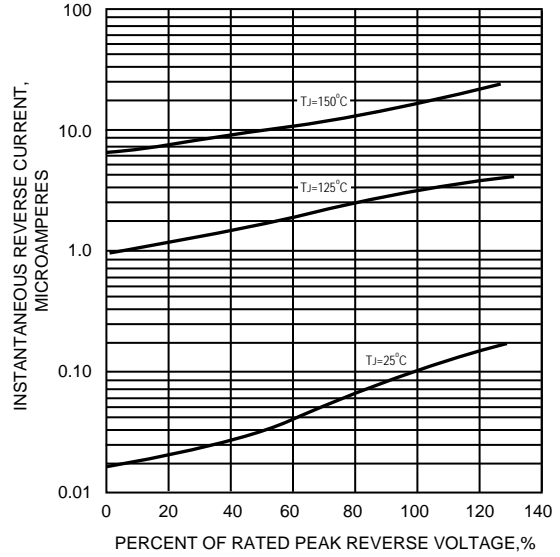
**FIG.1 - FORWARD CURRENT DERATING CURVE**

**FIG.2 - MAXIMUM NON-REPETITIVE PEAK FORWARD SURGE CURRENT**

**FIG.3 - TYPICAL INSTANTANEOUS FORWARD CHARACTERISTICS**

**FIG.4 - TYPICAL REVERSE CHARACTERISTICS PER BRIDGE ELEMENT**

**FIG.5 - TYPICAL JUNCTION CAPACITANCE**
