

C-1X-622(C)-TDFB(3)-SSC4



Features

- SC Duplex Single Mode Transceiver
- Industry Standard 1x9 Footprint
- Complies with SONET OC-12 SDH STM-4
- Single +3.3V/5V power supply
- Operating Temperature Range 0 to 70°C
- PECL Differential Inputs and Outputs
- TTL/LVTTL Signal Detection Output [C-1X-622C-TDFB(3)-SSC4]
- PECL/LVPECL Signal Detection Output [C-1X-622-TDFB(3)-SSC4]
- Wave Solderable and Aqueous Washable
- Uncooled laser diode with MQW structure
- Complies with Bellcore GR-468-CORE
- ATM 622 Mbps Link application
- SONET/SDH Equipment Interconnect application
- RoHS compliance available

Absolute Maximum Rating

Parameter	Symbol	Min.	Max.	Unit	Note
Power Supply Voltage	V_{cc}	0	6.0	V	C-1X-622(C)-TDFB-SSC4
Power Supply Voltage	V_{cc}	0	3.6	V	C-1X-622(C)-TDFB3-SSC4
Output Current	I_{out}	0	30	mA	
Soldering Temperature	-	-	240	°C	10 seconds on leads only
Operating temperature	T_{opr}	0	70	°C	
Storage Temperature	T_{stg}	-40	85	°C	

Recommended Operating Condition

Parameter	Symbol	Min.	Typ.	Max.	Unit	Note
Power Supply Voltage	V_{cc}	4.75	5	5.25	V	C-1X-622(C)-TDFB-SSC4
Power Supply Voltage	V_{cc}	3.1	3.3	3.5	V	C-1X-622(C)-TDFB3-SSC4
Operating Temperature (Case)	T_{opr}	0	-	70	°C	
Data Rate	-	-	622	-	Mbps	

Transmitter Specifications

Parameter	Symbol	Min	Typical	Max	Unit	Notes
Optical						
Optical Transmit Power	P_o	-3	-	+2	dBm	
Output center Wavelength	λ	1280	1310	1335	nm	C-13-622(C)-TDFB(3)-SSC4
Output center Wavelength	λ	1480	1550	1580	nm	C-15-622(C)-TDFB(3)-SSC4
Output Spectrum Width	$\Delta\lambda$	-	-	1	nm	-20 dB width
Side Mode Suppression Ratio	S_r	30	35	-	dB	
Extinction Ratio	ER	10	-	-	dB	
Output Eye	Compliant with ITU recommendation G.957					
Optical Rise Time	t_r	-	-	1.2	ns	10% to 90% Values
Optical Fall Time	t_f	-	-	1.2	ns	10% to 90% Values
Relative Intensity Noise	RIN	-	-	-120	dB/Hz	
Total Jitter	TJ	-	-	0.55	ns	Measured with 2 ²³ -1 PRBS with 72 ones and 72 zeros.

C-1X-622(C)-TDFB(3)-SSC4

Transmitter Specifications

Parameter	Symbol	Min	Typical	Max	Unit	Notes
Electrical						
Power Supply Current	I_{CC}	-	-	150	mA	Maximum current is specified at V_{CC} = Maximum @ maximum temperature
Data Input Current-Low	I_{IL}	-350	-	-	μ A	
Data Input Current-High	I_{IH}	-	-	350	μ A	
Differential Input Voltage	$V_{IH}-V_{IL}$	300	-	-	mV	
Data Input Voltage-Low	$V_{IL}-V_{CC}$	-2.0	-	-1.58	V	These inputs are compatible with 10K, 10KH and 100K ECL and PECL inputs
Data Input Voltage-High	$V_{IH}-V_{CC}$	-1.1	-	-0.74	V	

Receiver Specifications

Parameter	Symbol	Min	Typical	Max	Unit	Notes
Optical						
Sensitivity	-	-	-	-28	dBm	Measured with 2 ²³ -1 PRBS, BER= 10 ⁻¹⁰
Maximum Input Power	P_{in}	-3	-	-	dBm	
Signal Detect-Asserted	P_a	-	-	-28	dBm	Measured on transition: low to high
Signal Detect-Deasserted	P_d	-40	-	-	dBm	Measured on transition: high to low
Signal Detect-Hysteresis		-	3	-	dB	
Wavelength of Operation		1100	-	1600	nm	

Receiver Specifications

Parameter	Symbol	Min	Typical	Max	Unit	Note
Electrical						
Power Supply Current	I_{CC}	-	-	100	mA	The current excludes the output load current
Data Output Voltage-Low	$V_{OL}-V_{CC}$	-2.0	-	-1.58	V	These outputs are compatible with 10K, 10KH and 100KECL and PECL outputs
Data Output Voltage-High	$V_{OH}-V_{CC}$	-1.1	-	-0.74	V	
Signal Detect Output Voltage-Low	V_{SDL}	-	-	0.5	V	C-1X-622C-TDFB(3)-SSC4
Signal Detect Output Voltage-High	V_{SDH}	2.0	-	-	V	
Signal Detect Output Voltage-Low	$V_{SDL}-V_{CC}$	-2.0	-	-1.58	V	C-1X-622-TDFB(3)-SSC4
Signal Detect Output Voltage-High	$V_{SDH}-V_{CC}$	-1.1	-	-0.74	V	

C-1X-622(C)-TDFB(3)-SSC4

Connection Diagram

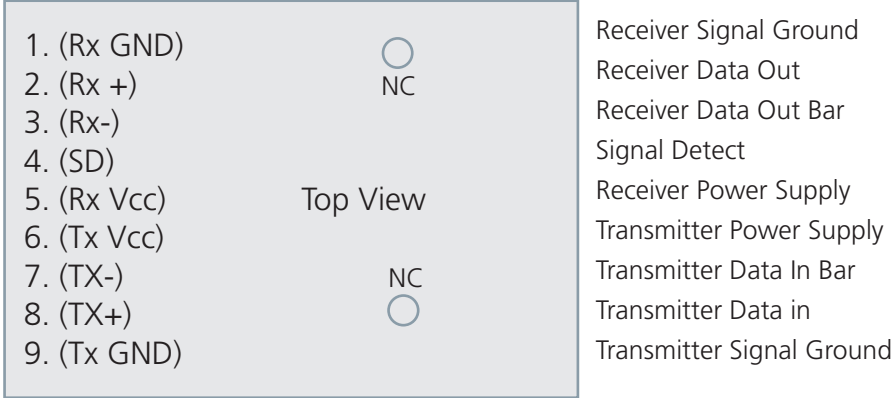

PIN	Symbol	Notes
1	RxGND	Directly connect this pin to the receiver ground plane
2	RD+	See recommended circuit schematic
3	RD-	See recommended circuit schematic
4	SD	Active high on this indicates a received optical signal
5	RxVcc	+3.3V/5V dc power for the receiver section
6	TxVcc	+3.3V/5V dc power for the transmitter section
7	TD-	See recommended circuit schematic
8	TD+	See recommended circuit schematic
9	TxGND	Directly connect this pin to the transmitter ground plane

C-1X-622(C)-TDFB(3)-SSC4

Recommended Circuit Schematic

C-1X-622-TDFB(3)-SSC4

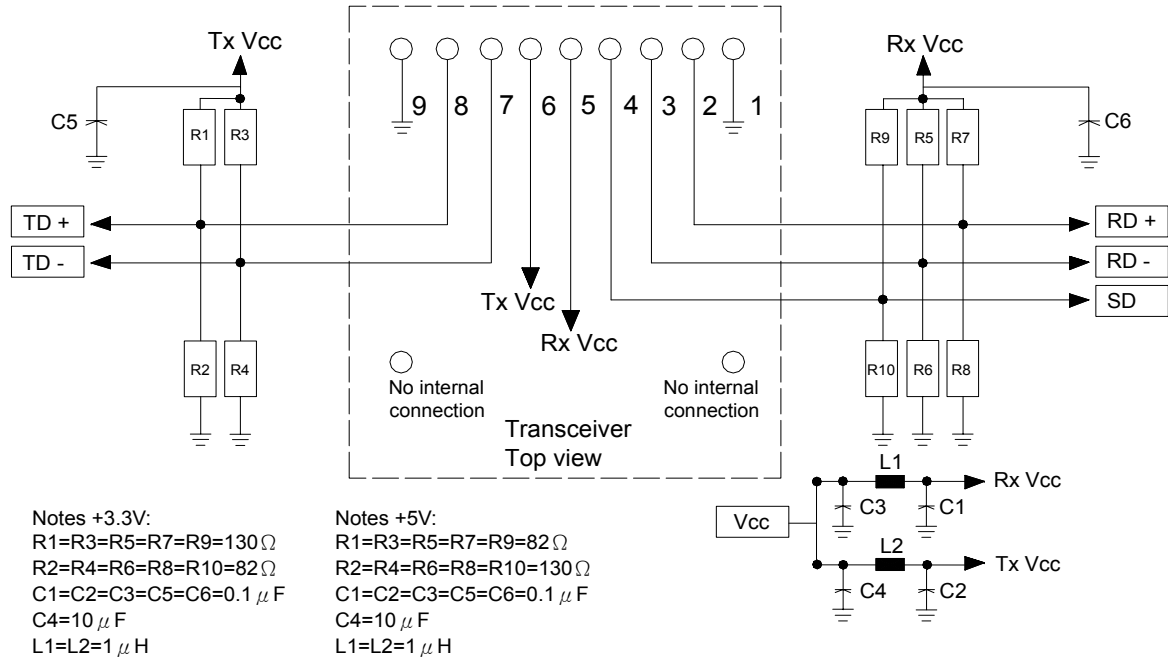

C-1X-622C-TDFB(3)-SSC4

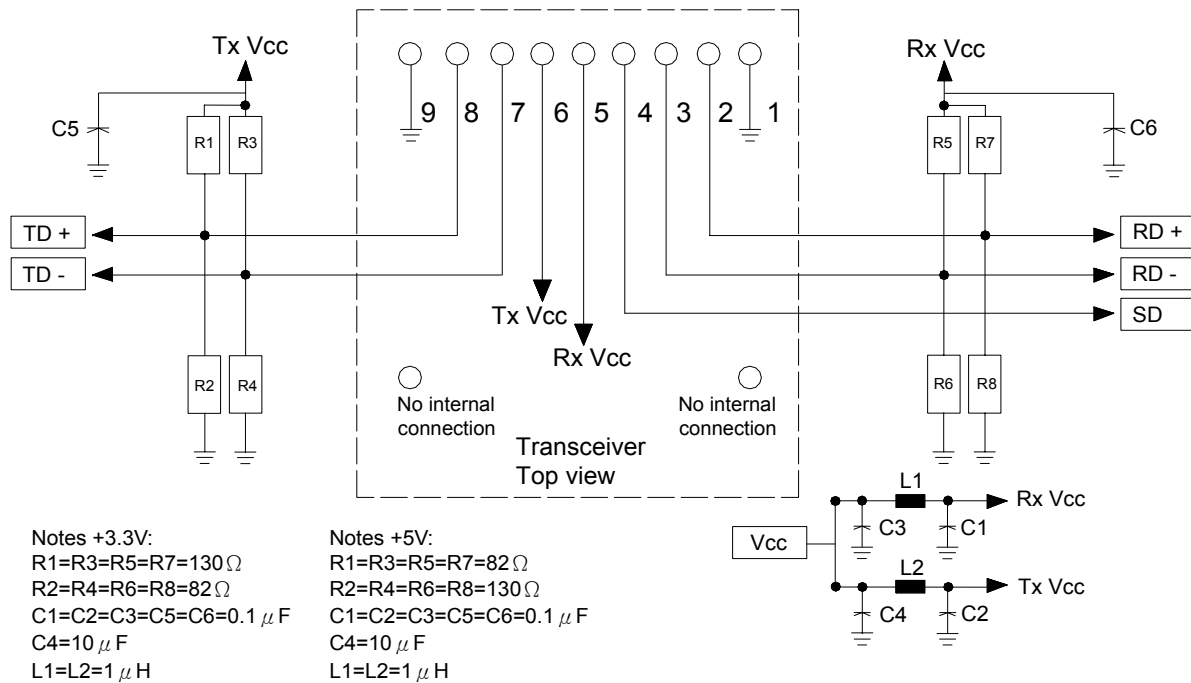

The split-loaded terminations for ECL signals need to be located at the input of devices receiving those ECL signals. The power supply filtering is required for good EMI performance. Use short tracks from the inductor L1/L2 to the module Rx Vcc. A GND plane under the module is required for good EMI and sensitivity performance.

C-1X-622(C)-TDFB(3)-SSC4

Package Diagram (10.4 mm SC transceiver assembly)

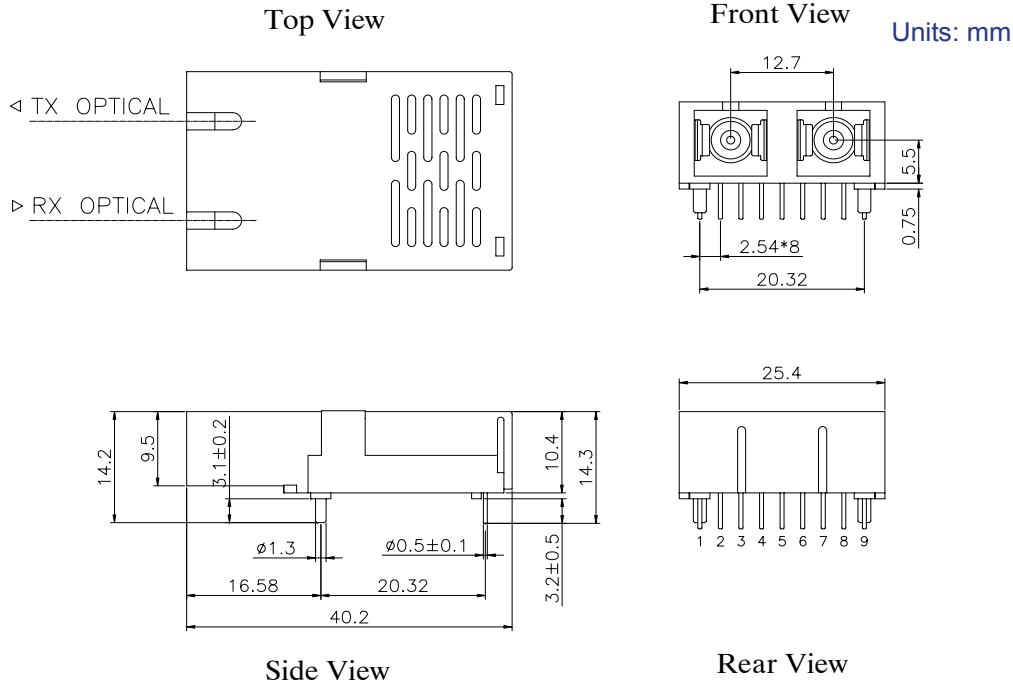

Package Optiot:
Blank / A = Black Case

Package Diagram (9.8 mm SC transceiver assembly)

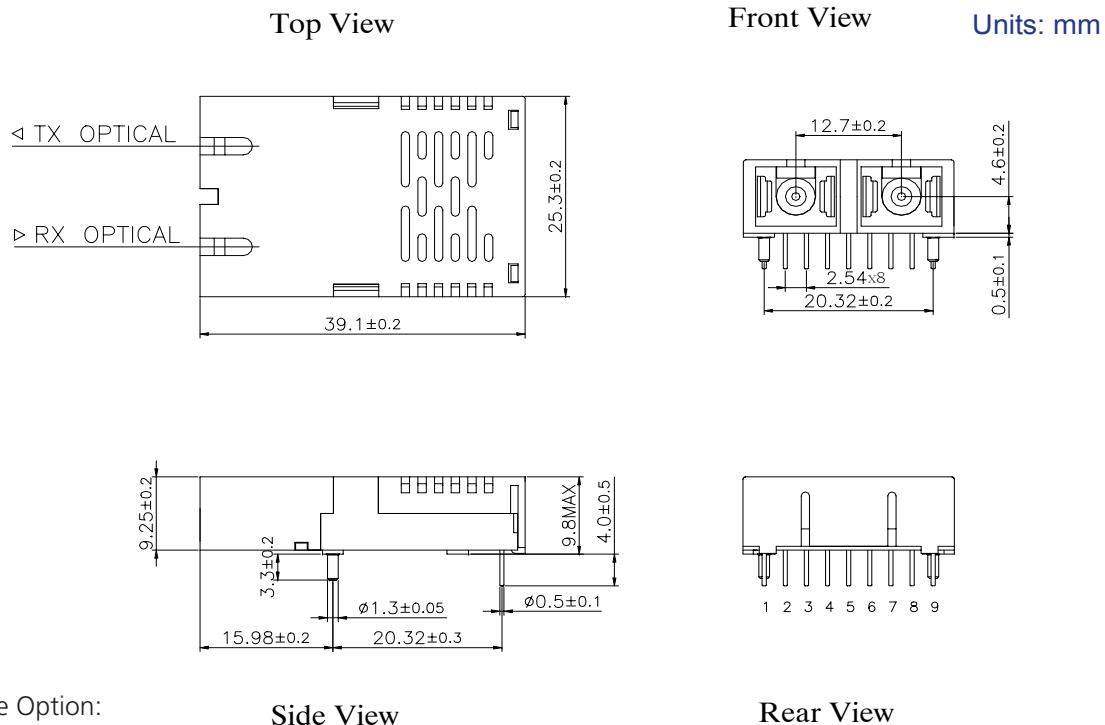

Package Option:
B / E : Blue case
C / D : Black case

C-1X-622(C)-TDFB(3)-SSC4

Ordering Information

Available Options:

C-13-622-TDFB(3)-SSC4	C-13-622C-TDFB(3)-SSC4	C-13-622-TDFB(3)-SSC4-G5	C-13-622C-TDFB(3)-SSC4-G5
C-13-622-TDFB(3)-SSC4A	C-13-622C-TDFB(3)-SSC4A	C-13-622-TDFB(3)-SSC4A-G5	C-13-622C-TDFB(3)-SSC4A-G5
C-13-622-TDFB(3)-SSC4B	C-13-622C-TDFB(3)-SSC4B	C-13-622-TDFB(3)-SSC4B-G5	C-13-622C-TDFB(3)-SSC4B-G5
C-13-622-TDFB(3)-SSC4C	C-13-622C-TDFB(3)-SSC4C	C-13-622-TDFB(3)-SSC4C-G5	C-13-622C-TDFB(3)-SSC4C-G5
C-13-622-TDFB(3)-SSC4D	C-13-622C-TDFB(3)-SSC4D	C-13-622-TDFB(3)-SSC4D-G5	C-13-622C-TDFB(3)-SSC4D-G5
C-13-622-TDFB(3)-SSC4E	C-13-622C-TDFB(3)-SSC4E	C-13-622-TDFB(3)-SSC4E-G5	C-13-622C-TDFB(3)-SSC4E-G5
C-15-622-TDFB(3)-SSC4	C-15-622C-TDFB(3)-SSC4	C-15-622-TDFB(3)-SSC4-G5	C-15-622C-TDFB(3)-SSC4-G5
C-15-622-TDFB(3)-SSC4A	C-15-622C-TDFB(3)-SSC4A	C-15-622-TDFB(3)-SSC4A-G5	C-15-622C-TDFB(3)-SSC4A-G5
C-15-622-TDFB(3)-SSC4B	C-15-622C-TDFB(3)-SSC4B	C-15-622-TDFB(3)-SSC4B-G5	C-15-622C-TDFB(3)-SSC4B-G5
C-15-622-TDFB(3)-SSC4C	C-15-622C-TDFB(3)-SSC4C	C-15-622-TDFB(3)-SSC4C-G5	C-15-622C-TDFB(3)-SSC4C-G5
C-15-622-TDFB(3)-SSC4D	C-15-622C-TDFB(3)-SSC4D	C-15-622-TDFB(3)-SSC4D-G5	C-15-622C-TDFB(3)-SSC4D-G5
C-15-622-TDFB(3)-SSC4E	C-15-622C-TDFB(3)-SSC4E	C-15-622-TDFB(3)-SSC4E-G5	C-15-622C-TDFB(3)-SSC4E-G5

Part numbering Definition:

C - 1X - 622(C) - TDFB(3) - S SC TxPower Temperature and Package -RoHS

- Wavelength
 - 13 = Wavelength 1310nm
 - 15 = Wavelength 1550nm
- Communication protocol
 - (622 Mbps)
 - 622 = PECL/VLPECL signal detection output
 - 622C = TTL/LVTTL signal detection output
- TDFB= +5V DFB Transceiver
TDFB3= +3.3V DFB Transceiver
- Single mode fiber
- Connector options
SC
- Tx Power range
4 = -3 to +2 dBm
- Temperature range and package
 - Blank / A = Black case 10.4 mm
 - B / E = Blue case 9.8 mm
 - C / D = Black case 9.8 mm
- Ordering Information
 - Blank = RoHS non-compliant product
 - G5 = RoHS 5/6-compliant product (lead exemption)
 - GR = Full RoHS compliant product (no exemption)

Warnings

Handling Precautions: This device is susceptible to damage as a result of electrostatic discharge (ESD). A static free environment is highly recommended. Follow guidelines according to proper ESD procedures.

Laser Safety: Radiation emitted by laser devices can be dangerous to human eyes. Avoid eye exposure to direct or indirect radiation.

Legal Notice

IMPORTANT NOTICE!

All information contained in this document is subject to change without notice, at LuminentOIC's sole and absolute discretion. LuminentOIC warrants performance of its products to current specifications only in accordance with the company's standard one-year warranty; however, specifications designated as "preliminary" are given to describe components only, and LuminentOIC expressly disclaims any and all warranties for said products, including express, implied, and statutory warranties, warranties of merchantability, fitness for a particular purpose, and non-infringement of proprietary rights. Please refer to the company's Terms and Conditions of Sale for further warranty information.

LuminentOIC assumes no liability for applications assistance, customer product design, software performance, or infringement of patents, services, or intellectual property described herein. No license, either express or implied, is granted under any patent right, copyright, or intellectual property right, and LuminentOIC makes no representations or warranties that the product(s) described herein are free from patent, copyright, or intellectual property rights. Products described in this document are NOT intended for use in implantation or other life support applications where malfunction may result in injury or death to persons. LuminentOIC customers using or selling products for use in such applications do so at their own risk and agree to fully defend and indemnify LuminentOIC for any damages resulting from such use or sale.

THE INFORMATION CONTAINED IN THIS DOCUMENT IS PROVIDED ON AN "AS IS" BASIS. Customer agrees that LuminentOIC is not liable for any actual, consequential, exemplary, or other damages arising directly or indirectly from any use of the information contained in this document. Customer must contact LuminentOIC to obtain the latest version of this publication to verify, before placing any order, that the information contained herein is current.

© LuminentOIC, Inc. 2003
All rights reserved