

**CONNECTOR DESIGNATORS**  
**A-B\*-C-D-E-F**  
**G-H-J-K-L-S**  
 \* Conn. Desig. B See Note 7  
**DIRECT COUPLING**

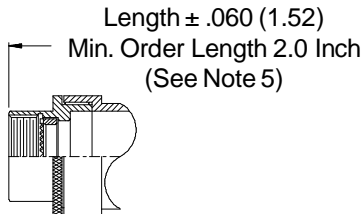

**STYLE 2 (STRAIGHT)**  
 See Note 1)

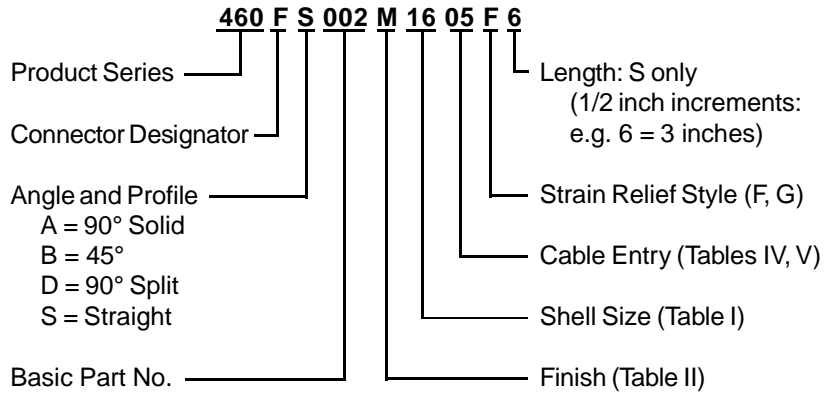
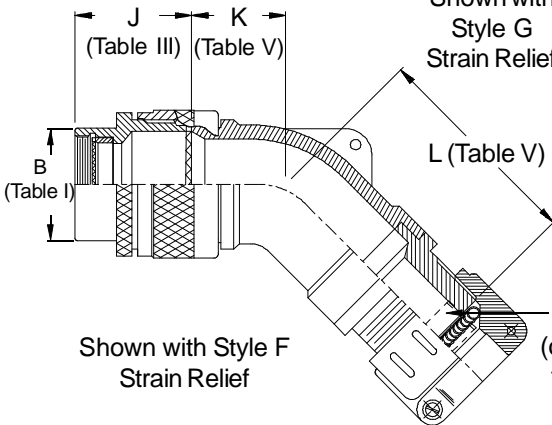
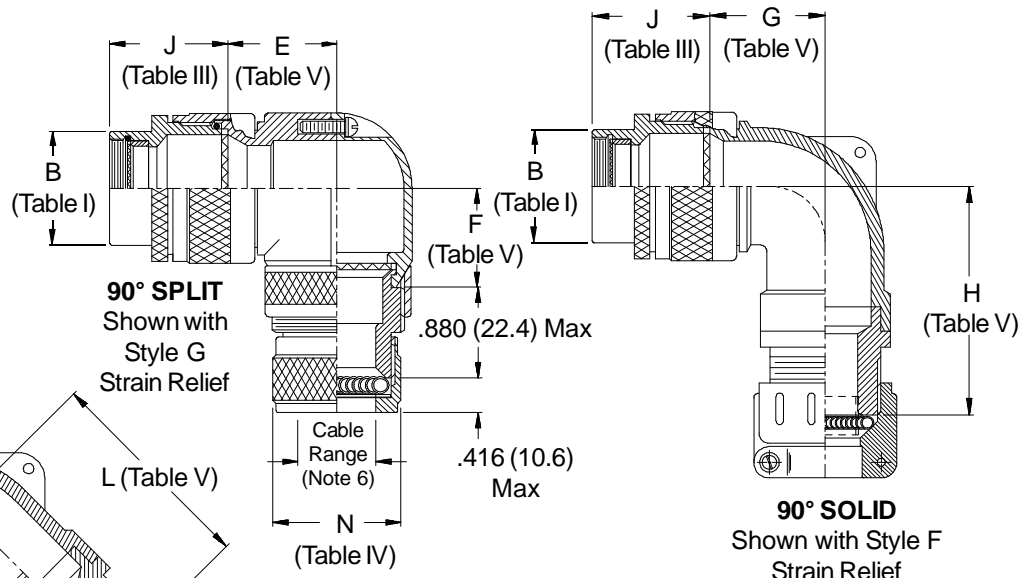
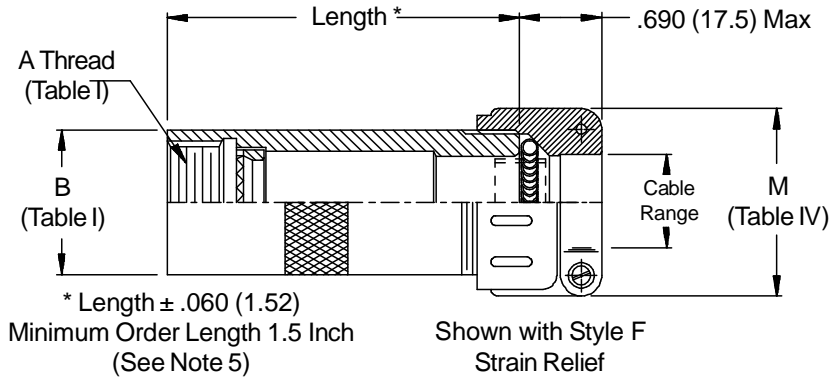

469-001-XX Shield Support Ring (order separately) is recommended for use in all G-Spring backshells (see page 463-8)

**460-002**  
**EMI/RFI Non-Environmental G-Spring Backshell**  
with Strain Relief  
**Direct Coupling - Low Profile and Split 90°**



See inside back cover fold-out or pages 13 and 14 for Tables I and II.

TABLE III: FRONT ADAPTER			
Shell Size	J Max - Conn. Designator		
	A-D-E-F	B-G-K	C
	J-H-L-S		
08/09	1.000 (25.4)	1.250 (31.8)	
10/11	1.000 (25.4)	1.250 (31.8)	
12/13	1.000 (25.4)	1.250 (31.8)	1.735 (44.1)
14/15	1.000 (25.4)	1.250 (31.8)	1.915 (48.6)
16/17	1.000 (25.4)	1.416 (36.0)	1.915 (48.6)
18/19	1.000 (25.4)	1.416 (36.0)	1.915 (48.6)
20/21	1.000 (25.4)	1.416 (36.0)	1.915 (48.6)
22/23	1.000 (25.4)	1.416 (36.0)	1.915 (48.6)
24/25	1.000 (25.4)	1.416 (36.0)	1.915 (48.6)
28/29	1.000 (25.4)	1.416 (36.0)	1.915 (48.6)
32/33	1.000 (25.4)	1.416 (36.0)	1.915 (48.6)
36	1.000 (25.4)	1.416 (36.0)	1.915 (48.6)
40	1.000 (25.4)	1.687 (42.9)	1.915 (48.6)

TABLE IV: CABLE ENTRY							
Dash No.	M Max	N Max	Cable Range				
			Min	Max			
01	.843 (21.4)	.625 (15.9)	.156 (4.0)	.250 (6.4)			
02	.968 (24.6)	.750 (19.1)	.188 (4.8)	.375 (9.5)			
03	1.046 (26.6)	.875 (22.2)	.250 (6.4)	.438 (11.1)			
04	1.156 (29.4)	1.000 (25.4)	.280 (7.1)	.500 (12.7)			
05	1.218 (30.9)	1.125 (28.6)	.375 (9.5)	.625 (15.9)			
06	1.343 (34.1)	1.250 (31.8)	.500 (12.7)	.750 (19.1)			
07	1.468 (37.3)	1.375 (34.9)	.625 (15.9)	.875 (22.2)			
08	1.593 (40.5)	1.500 (38.1)	.750 (19.1)	1.000 (25.4)			
09	1.718 (43.6)	1.625 (41.3)	.875 (22.2)	1.125 (28.6)			
10	1.843 (46.8)	1.750 (44.5)	1.000 (25.4)	1.250 (31.8)			
11*	2.187 (55.5)	1.875 (47.6)	1.125 (28.6)	1.375 (34.9)			
12*	2.312 (58.7)	2.000 (50.8)	1.250 (31.8)	1.500 (38.1)			
13*	2.437 (61.9)	2.125 (54.0)	1.375 (34.9)	1.625 (41.3)			
14*	2.546 (64.7)	2.250 (57.2)	1.500 (38.1)	1.750 (44.5)			

\* Consult factory for availability

TABLE V: DIMENSIONS							
Dash No.	E Max	F Max	G Max	H Max	K Max	L Max	
01	.680 (17.3)	.560 (14.2)	.636 (16.2)	1.670 (42.4)	.630 (16.0)	1.720 (43.7)	
02	.750 (19.1)	.620 (15.7)	.710 (18.0)	1.790 (45.5)	.630 (16.0)	1.720 (43.7)	
03	.810 (20.6)	.690 (17.5)	.734 (18.6)	1.810 (46.0)	.692 (17.6)	1.780 (45.2)	
04	.870 (22.1)	.720 (18.3)	.825 (21.0)	1.880 (47.8)	.755 (19.2)	1.870 (47.5)	
05	.930 (23.6)	.820 (20.8)	.988 (25.1)	1.970 (50.0)	.848 (21.5)	1.980 (50.3)	
06	1.000 (25.4)	.880 (22.4)	1.087 (27.6)	2.140 (54.4)	1.036 (26.3)	2.170 (55.1)	
07	1.060 (26.9)	.940 (23.9)	1.087 (27.6)	2.140 (54.4)	1.036 (26.3)	2.170 (55.1)	
08	1.120 (28.4)	1.000 (25.4)	1.325 (33.7)	2.250 (57.2)	1.130 (28.7)	2.320 (58.9)	
09	1.180 (30.0)	1.060 (26.9)	1.325 (33.7)	2.250 (57.2)	1.130 (28.7)	2.320 (58.9)	
10	1.180 (30.0)	1.060 (26.9)	1.337 (34.0)	2.420 (61.5)	1.255 (31.9)	2.370 (60.2)	
11	1.312 (33.3)	1.219 (31.0)	1.827 (46.4)	2.670 (67.8)	1.317 (33.5)	2.470 (62.7)	
12	1.562 (39.7)	1.438 (36.5)	1.827 (46.4)	2.670 (67.8)	1.317 (33.5)	2.470 (62.7)	
13	1.562 (39.7)	1.438 (36.5)	2.027 (51.5)	2.670 (67.8)	1.348 (34.2)	2.560 (65.0)	
14	1.688 (42.9)	1.656 (42.1)	2.027 (51.5)	2.670 (67.8)	1.348 (34.2)	2.560 (65.0)	

1. Shield Support Ring (469-001-XX) is recommended for use in all G-Spring backshells (see page 463-8).
2. When maximum cable entry (page 22) is exceeded, Style 2 will be supplied. Angular Function S only.
3. Metric dimensions (mm) are indicated in parentheses.
4. Cable range is defined as the accommodations range for the wire bundle or cable. Dimensions shown are not intended for inspection criteria.
5. Consult factory for shorter lengths on straight backshells.
6. Maximum cable entry available for split elbow is 1.188 (30.2).
7. When using Connector Designator B refer to pages 18 and 19 for part number development.