

DESCRIPTION:

The 633 series is oval type specially designed for full color video and information signs. These devices are excellent for outdoor application where a wide viewing angle and readability in sunlight are essential. The semi-conductor materials used are: GaP for (633HD/HT, 633GC/GD/GT) GaAsP/GaP for (633RHC/RHD/RHT, 633YC/YD/YT and 633SD)

PACKAGE DIMENSIONS

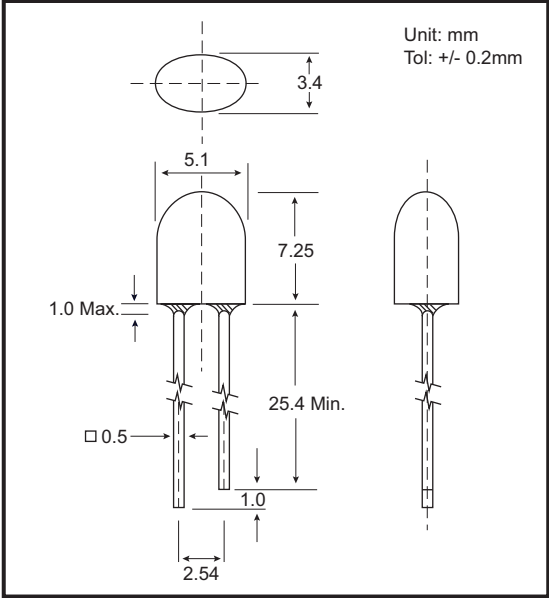

ABSOLUTE MAXIMUM RATINGS: (Ta=25°C)

Reverse Voltage	5 Volt
Reverse Current (Vr =5V)	100µA
Operating Temperature Range	-40°C To 85°C
Storage Temperature Range	-40°C To 100°C
Lead Soldering Temperature (1.6mm (1/16)From Body)	260°C For 5 Seconds

- NOTES : 1. All dimensions are in millimeters.
 2. Lead spacing is measured where the leads emerge from the package.
 3. Protuded resin under flange is 1.5 mm (0.059") Max.
 4. Specifications are subject to change without notice.

PART NO. SELECTION AND APPLICATION INFORMATION (RATINGS AT 25°C AMBIENT)

Part No.	Emitted Color	Lens Color	Peak Wavelength λp (nm)	Vf (v)		Rec. If (mA).	Iv (mcd)		View Angle 2θ1/2(Deg)
				Min	Max		Min	Typ.	
GB-633HT	Red	Red Trans.	697	1.7	2.6	5-10	1.0	15.0	X-AXIS = 110 Y-AXIS = 35
GB-633RHT	Bright Red	Red Trans.	660	1.7	2.6	10-20	6.0	30.0	X-AXIS = 110 Y-AXIS = 35
GB-633GT	Green	Green Trans.	565	1.7	2.6	10-20	6.0	30.0	X-AXIS = 110 Y-AXIS = 35
GB-633YT	Yellow	Yellow Trans.	585	1.7	2.6	10-20	6.0	30.0	X-AXIS = 110 Y-AXIS = 35
GB-633RHC	Bright Red	Water Clear	660	1.7	2.6	10-20	6.0	30.0	X-AXIS = 110 Y-AXIS = 35
GB-633GC	Green	Water Clear	565	1.7	2.6	10-20	6.0	30.0	X-AXIS = 110 Y-AXIS = 35
GB-633YC	Yellow	Water Clear	585	1.7	2.6	10-20	6.0	30.0	X-AXIS = 110 Y-AXIS = 35

TESTING CONDITION FOR EACH PARAMETER :

PARAMETER:	SYMBOL	UNIT	TEST CONDITION
REVERSE VOLTAGE	Vr	VOLT	Vr = 5.0 Volt
REVERSE CURRENT	Ir	µA	If = 20mA
FORWARD VOLTAGE	Vf	VOLT	If = 20mA
LUMINOUS INTENSITY	Iv	MCD	If = 20mA
VIEWING ANGLE	2θ1/2	DEGREE	
RECOMMENDED OPERATING CURRENT	If (Rec)	mA	

