

Three Termination Capacitor Type KGM

ISO 9001:2000
CERTIFIED
TS-16949
CERTIFIED

1. Features

- Surface mount type noise filter
- Plated terminals provide excellent solder resistance
- Small size and high rated DC current
- 0603-2A, 0805-2A, 1206-2A series is available in signal lines in addition to power line

2. Applications

- Noise reduction in high frequency circuits
- D.C. power line
- Vcc line for gate array or microcomputer

3. Ordering & Specifying Information

Type designation shall be as the following form.

KGM	0805	H	C	T	TE	220	2A
Type	Size	Rated Voltage	Temp. Charact.	Termination Material	Packaging	Capacitance	Rated Current
	0603 0805 1206 1812	C: 16V E: 25V V: 35V H:50V	C F	T: Sn	TE: 7" Embossed Taping 0603: 4,000 pcs/reel 0805: 4,000 pcs/reel 1206: 2,000 pcs/reel 1812: 1,000 pcs/reel	2 significant figures + No. of zeros	2A 4A

4. Dimension and Structure

4.1 Circuit

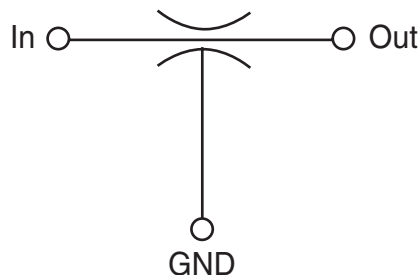

4.2 Dimension

Dimensions in inches (mm)

Size	L	W	T	g	e
0603	0.063 (1.6 ± 0.2)	0.031 (0.8 ± 0.2)	0.024 (0.6 ± 0.2)	0.020 (0.5 ± 0.3)	0.008 (0.2 ± 0.15)
0805	0.079 (2.0 ± 0.2)	0.049 (1.25 ± 0.2)	0.031 (0.8 ± 0.2*)	0.016 (0.4 ± 0.3)	0.012 (0.3 ± 0.2)
1206	0.126 (3.2 ± 0.2)	0.063 (1.6 ± 0.2)	0.031 (0.8 ± 0.2*)	0.039 (1.0 ± 0.3)	0.016 (0.4 ± 0.3)
1812	0.177 (4.5 ± 0.3)	0.126 (3.2 ± 0.3)	0.039 (1.0 ± 0.2)	0.039 (1.0 ± 0.3)	0.016 (0.4 ± 0.3)

* KGM0805 470
KGM0805 101
KGM0805 220
KGM0805 105
T: 0.035 ± (0.9 ± 0.2)

KGM1206CHT221/2A: T = 0.043 (1.1 ± 0.2)

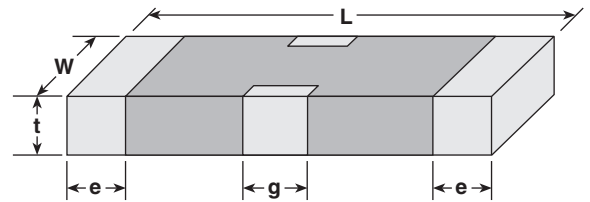

5. Structure

Single Layer Type

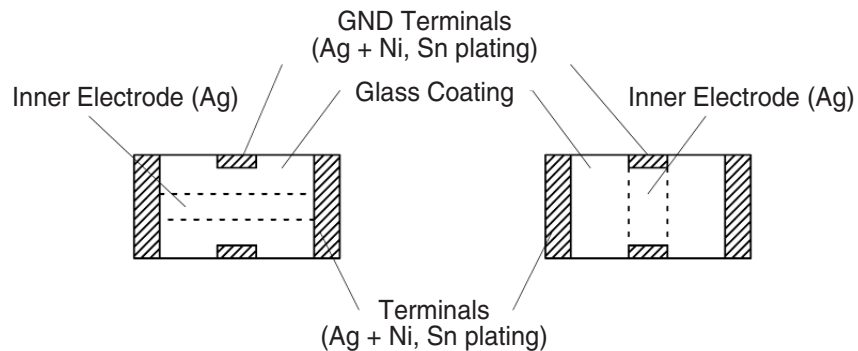

Multilayer Type

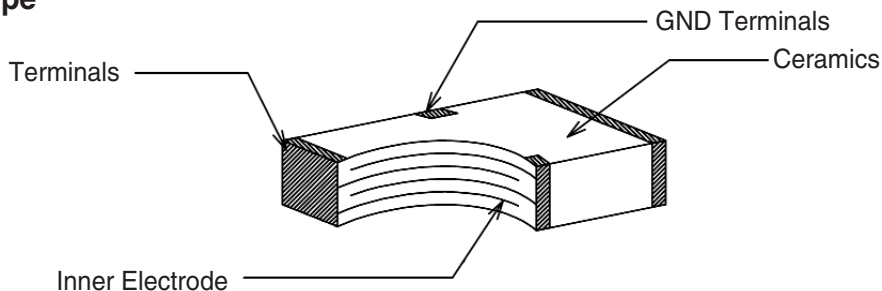

6. Standard Applications

Part Designation	Capacitance (pF)	Capacitance Tolerance (%)	Rated Voltage DC (V)	Rated Current DC (A)	Insulation Resistance Minimum (MΩ)	Operating Temperature Range
KGM0603ECTTE2202A	22	+50 ~ -20	25	2	1000	-40°C to +85°C
KGM0603ECTTE4702A	47					
KGM0603ECTTE1012A	100					
KGM0603ECTTE2212A	220					
KGM0603ECTTE4712A	470					
KGM0603ECTTE1022A	1000		16			
KGM0603CCTTE2222A	2200					
KGM0603CCTTE3322A	3300					
KGM0603CFTTE2232A	22,000					
KGM0603CFTTE1042A	100,000					
KGM0805HCTTE2202A	22	+50 ~ -20	50	2	1000	-40°C to +85°C
KGM0805HCTTE4702A	47					
KGM0805HCTTE1012A	100					
KGM0805ECTTE2212A	220					
KGM0805ECTTE4712A	470					
KGM0805ECTTE1022A	1000		25			
KGM0805ECTTE2222A	2200					
KGM0805ECTTE3322A	3300					
KGM0805EFTTE1042A	100,000					
KGM0805CFTTE1052A	1,000,000					
KGM1206HCTTE2202A	22	+50 ~ -20	50	2	1000	-40°C to +85°C
KGM1206HCTTE4702A	47					
KGM1206HCTTE1012A	100					
KGM1206HCTTE2212A	220					
KGM1206HCTTE4712A	470					
KGM1206HCTTE1022A	1000		35			
KGM1206VCTTE2222A	2200					
KGM1206ECTTE2722A	2700					
KGM1206ECTTE3322A	3300					
KGM1206ECTTE1032A	10,000					
KGM1206EFTTE1042A	100,000	+50 ~ -20	50	2	1000	-40°C to +85°C
KGM1812HCTTE4714A	470					
KGM1812HCTTE1024A	1000					
KGM1812HCTTE2224A	2200		25			
KGM1812ECTTE6824A	6800					

7. Pattern design

The land pattern is recommended as follows.

0603 Chip Mounting Side

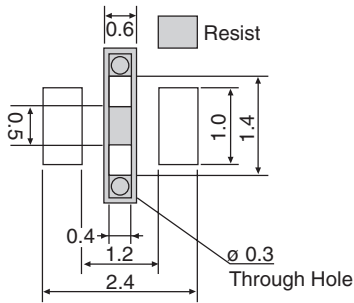

0805 Chip Mounting Side

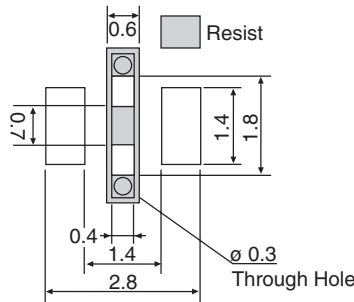

1206 Chip Mounting Side

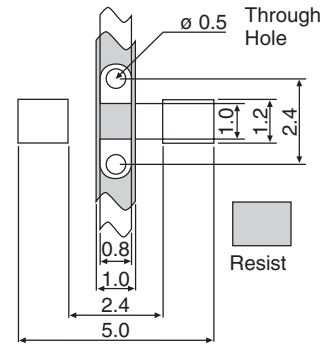

1812 Chip Mounting Side

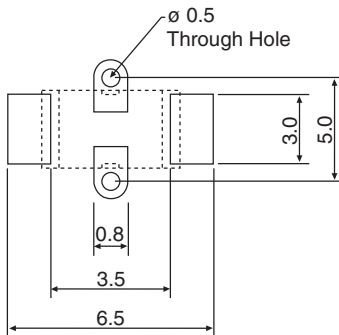

0603, 0805, 1206, 1812 Back Side

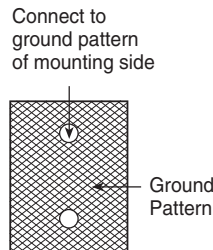

(unit: mm)

8. Characteristics

Item	Requirement	Conditions
Insulation Resistance	Min 1000M ohms	Applied rated voltage for 60 seconds.
Capacitance	Within the tolerance	Frequency: 1kHz Voltage: 1Vrms
DC Resistance	Max 60m ohms	DC: 0.3V Max.
Dielectric Withstanding Strength	No break down	Applied 250% of the rated voltage for 1 to 5 seconds. Limit surge current 50mA max.

8. Characteristics Cont.

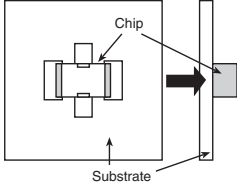
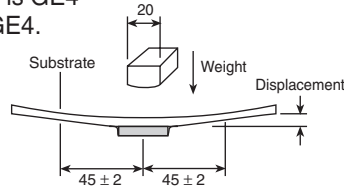
Item	Requirement	Conditions															
Terminal Adhesion Strength	No physical damage	Solder a chip to a test substrate and then laterally apply a load (5N, 500gF) in the arrow direction. 															
Soldering Heat Resistance	Appearance: No physical damage Capacitance: Within tolerance Dielectric Loss: Within tolerance Insulation Resistance: Within tolerance	Flux: 25% rosin Pre-heating: 60 sec Pre-heating Temp: 150°C Solder: H60A Solder Temp: 260°C ±5°C Dip Time: 5 ±0.5 sec															
Solderability	More than 95% of the terminal electrode shall be covered with new solder.	Flux: 25% rosin Pre-heating: 60 sec Pre-heating Temp: 150°C Solder: H60A Solder Temp: 230°C ±5°C Dip Time: 4 ±1 sec															
Temperature Cycle	Appearance: No physical damage Capacitance: Within tolerance Dielectric Loss: Within tolerance Insulation Resistance: Within tolerance	Repeat the following heat cycle 10 times: <table border="1" style="margin-left: 40px;"> <thead> <tr> <th>Step</th> <th>Temperature</th> <th>Time</th> </tr> </thead> <tbody> <tr> <td>1</td> <td>-40°C ±3°C</td> <td>30 min ±3 min</td> </tr> <tr> <td>2</td> <td>Room Temp.</td> <td>15 min max.</td> </tr> <tr> <td>3</td> <td>85°C ±2°C</td> <td>30 min ±3 min</td> </tr> <tr> <td>4</td> <td>Room Temp.</td> <td>15 min max.</td> </tr> </tbody> </table>	Step	Temperature	Time	1	-40°C ±3°C	30 min ±3 min	2	Room Temp.	15 min max.	3	85°C ±2°C	30 min ±3 min	4	Room Temp.	15 min max.
Step	Temperature	Time															
1	-40°C ±3°C	30 min ±3 min															
2	Room Temp.	15 min max.															
3	85°C ±2°C	30 min ±3 min															
4	Room Temp.	15 min max.															
High Temperature Resistance	Appearance: No physical damage Capacitance: Within tolerance Dielectric Loss: Within tolerance Insulation Resistance: Within tolerance	Temp: 70°C ±2°C Bias: 150% of rated voltage Test Time: 1000+48/-0 hour															
Humidity Resistance (unload)	Appearance: No physical damage Capacitance: Within tolerance Dielectric Loss: Within tolerance Insulation Resistance: Within tolerance	Temp: 85°C ±2°C Humidity: 85% ±5% Test Time: 500+24/-0 hour															
Vending Substrate	Appearance: No physical damage Capacitance: Within tolerance	After soldering a chip to a test substrate, bend the substrate by 1 mm and then measure. The substrate is GE4 or based on GE4. 															

8. Characteristics Cont.

Item	Requirement	Conditions
Humidity Resistance (load)	Appearance: No physical damage Capacitance: Within tolerance Dielectric Loss: Within tolerance Insulation Resistance: Within tolerance	Temp: 40°C ±2°C Humidity: 90 - 95% Bias: 100% of rated voltage Test Time: 500+24/-0 hour
Low Temperature Resistance (unload)	Appearance: No physical damage Capacitance: Within tolerance Dielectric Loss: Within tolerance Insulation Resistance: Within tolerance	Temp: -40°C ±2°C Test Time: 1000+48/-0 hour
Vibration	Appearance: No physical damage Capacitance: Within tolerance Dielectric Loss: Within tolerance Insulation Resistance: Within tolerance	The frequency of applied vibration should be swept from 10 Hz to 55 Hz and return to 10 Hz. This cycle time should be about 1 min and this cycle should be repeated. Amplitude (total Excursion): 1.5 mm This motion shall be applied for period of 2 hours in each 3 mutually perpendicular axes. (total of 6 hours)

After Temperature cycle test, High temperature resistance test, Humidity resistance test or Low temperature resistance test, the tested sample should be measured after having left in temperature from 15° to 35°C and relative humidity from 45% to 75% for 24 hours.

9. Packaging Specifications

9.1 Taping

Packaging of components on continuous tape is complete with carrier tape for putting components and cover tape for sealing.

(1) Dimensions of Carrier Tape

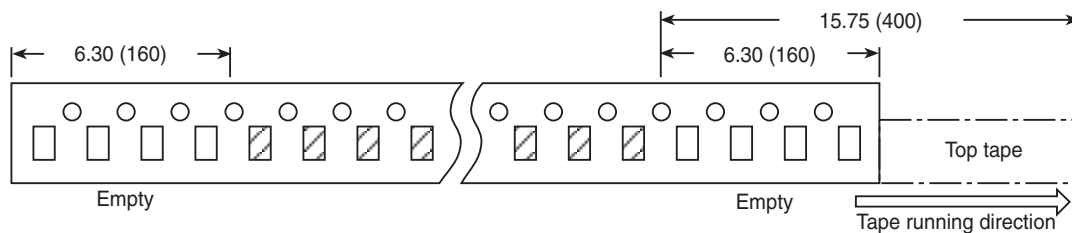

9-1 Taping Cont.

Taping shape in accordance with EIAJ RC-1009B

(2) Dimensions of Embossed Carrier Tape

Dimensions in inches (mm)

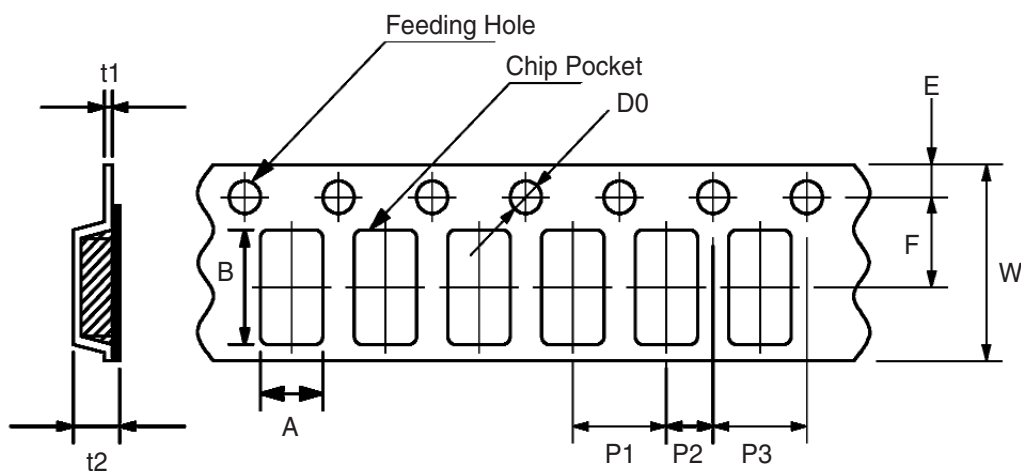

Dimensions in inches (mm)

Series	A	B	W	F	E	P1
KGM0603 Series	0.043 ± 0.002 (1.1 ± 0.05)	0.075 ± 0.002 (1.9 ± 0.05)	0.314 ± 0.003 (8.0 ± 0.1)	0.137 ± 0.002 (3.5 ± 0.05)	0.068 ± 0.003 (1.75 ± 0.1)	0.157 ± 0.003 (4.0 ± 0.1)
KGM0805 Series	0.061 ± 0.003 (1.55 ± 0.1)	0.091 ± 0.003 (2.3 ± 0.1)	0.314 ± 0.008 (8.0 ± 0.2)	0.137 ± 0.002 (3.5 ± 0.05)	0.068 ± 0.003 (1.75 ± 0.1)	0.157 ± 0.003 (4.0 ± 0.1)
KGM1206 Series	0.078 ± 0.003 (2.0 ± 0.1)	0.137 ± 0.003 (3.5 ± 0.1)	0.314 ± 0.011 (8.0 ± 0.3)	0.137 ± 0.002 (3.5 ± 0.05)	0.068 ± 0.003 (1.75 ± 0.1)	0.157 ± 0.003 (4.0 ± 0.1)
KGM1812 Series	0.137 ± 0.007 (3.5 ± 0.2)	0.192 ± 0.003 (4.9 ± 0.1)	0.472 ± 0.011 (12.0 ± 0.3)	0.216 ± 0.002 (5.5 ± 0.05)	0.068 ± 0.003 (1.75 ± 0.1)	0.157 ± 0.003 (4.0 ± 0.1)

Dimensions in inches (mm)

Series	P2	P3	D0	t1	t2
KGM0603 Series	0.078 ± 0.02 (2.0 ± 0.05)	0.157 ± 0.003 (4.0 ± 0.1)	0.059 + ^{0.003} / ₋₀ (1.5 + ^{0.1} / ₋₀)	0.011 ± 0.001 (0.3 ± 0.05)	0.098 (2.5 max)
KGM0805 Series	0.078 ± 0.02 (2.0 ± 0.05)	0.157 ± 0.003 (4.0 ± 0.1)	0.059 + ^{0.003} / ₋₀ (1.5 + ^{0.1} / ₋₀)	0.011 ± 0.001 (0.3 ± 0.05)	0.098 (2.5 max)
KGM1206 Series	0.078 ± 0.02 (2.0 ± 0.05)	0.157 ± 0.003 (4.0 ± 0.1)	0.059 + ^{0.003} / ₋₀ (1.5 + ^{0.1} / ₋₀)	0.011 ± 0.001 (0.3 ± 0.05)	0.098 (2.5 max)
KGM1812 Series	0.078 ± 0.02 (2.0 ± 0.05)	0.157 ± 0.003 (4.0 ± 0.1)	0.059 + ^{0.003} / ₋₀ (1.5 + ^{0.1} / ₋₀)	0.011 ± 0.001 (0.3 ± 0.05)	0.098 (2.5 max)

(2) Reel specifications for taping

(3) Standard Packing Quantity

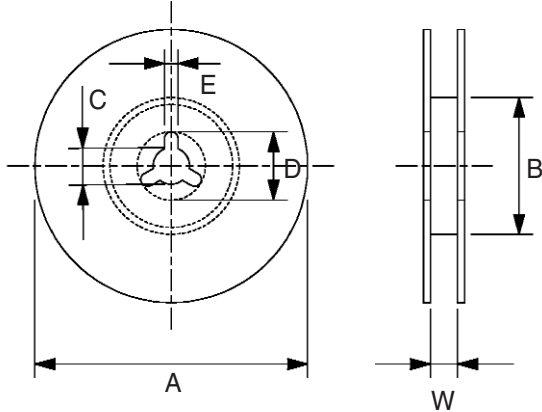

Series Name	Quantity
KGM0603 Series	4,000 pcs/reel
KGM0805 Series	4,000 pcs/reel
KGM1206 Series	2,000 pcs/reel
KGM1812 Series	1,000 pcs/reel

Dimensions in inches (mm)

Series	A	B	C	D	E	W (min)	W (max)
0603	7.00 ± 0.78 (178 ± 2)	2.36 (60 min)	0.511 ^{+0.02} _{-0.008} (13 ^{+0.5} _{-0.2})	0.83 ± 0.03 (21 ± 0.8)	0.079 ± 0.02 (2 ± 0.5)	0.311 ± 0.059 (7.9 ± 1.5)	0.429 ± 0.059 (10.9 ± 1.5)
0805							—
1206						0.468 ± 0.059 (11.9 ± 1.5)	0.606 ± 0.059 (15.4 ± 1.5)
1812							

10. Soldering

KOA filters have Ag (or Ag-Pd) Ni barrier terminals, overplated with Sn for use in either wave or reflow soldering processes.

Ceramics are very sensitive in general to thermal shock. Therefore KOA filters should not be exposed to sudden temperature increases or partial heating.

Prior to soldering, KOA filters shall be preheated so that the temperature difference during soldering will be kept within 130°C.

It is desirable that soldering temperature be kept to 240 ~ 250°C and soldering time be within 4 seconds.

Flux shall be Rosin type. Do not use strong acid type fluxes.

The tip of soldering iron should be 20 W. 3 mmø maximum.

The tip of soldering iron should be 220 - 250°C maximum. Care must be taken not to physically damage the chip through abnormal contact with soldering irons.