

2SC5772

Silicon NPN Epitaxial
VHF/UHF wide band amplifier

REJ03G0755-0200
(Previous ADE-208-1390)
Preliminary
Rev.2.00
Aug.10.2005

Features

- High gain bandwidth product
 $f_T = 9 \text{ GHz typ.}$
- High power gain and low noise figure ;
 $PG = 13 \text{ dB typ., } NF = 1.1 \text{ dB typ. at } f = 900 \text{ MHz}$

Outline

RENESAS Package code: PLSP0003ZB-A
(Package name: MPAK)

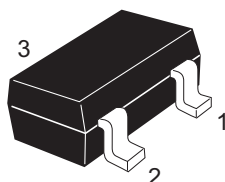

1. Emitter
2. Base
3. Collector

Note: Marking is "FR-".

Absolute Maximum Ratings

($T_a = 25^\circ\text{C}$)

Item	Symbol	Ratings	Unit
Collector to base voltage	V_{CBO}	15	V
Collector to emitter voltage	V_{CEO}	9	V
Emitter to base voltage	V_{EBO}	1.5	V
Collector current	I_C	75	mA
Collector power dissipation	P_C	700*	mW
Junction temperature	T_j	150	$^\circ\text{C}$
Storage temperature	T_{stg}	-55 to +150	$^\circ\text{C}$

* When using aluminum ceramic board (25 x 60 x 0.7 mm)

This data sheet contains tentative specification for new product development. It may partially be subject to change without notice.

Electrical Characteristics

(Ta = 25°C)

Item	Symbol	Min	Typ	Max	Unit	Test Conditions
Collector to base breakdown voltage	$V_{(BR)CBO}$	15	—	—	V	$I_C = 10 \mu A, I_E = 0$
Collector cutoff current	I_{CBO}	—	—	1	μA	$V_{CB} = 12 V, I_E = 0$
Collector cutoff current	I_{CEO}	—	—	1	mA	$V_{CE} = 9 V, R_{BE} = \infty$
Emitter cutoff current	I_{EBO}	—	—	10	μA	$V_{EB} = 1.5 V, I_C = 0$
DC current transfer ratio	h_{FE}	80	120	160		$V_{CE} = 5 V, I_C = 20 mA$
Collector output capacitance	C_{ob}	—	0.9	1.5	pF	$V_{CB} = 5 V, I_E = 0$ $f = 1 MHz$
Reverse transfer capacitance	C_{re}	—	0.7	—	pF	$V_{CB} = 5 V, I_E = 0$ $f = 1 MHz$
Gain bandwidth product	f_T	6	9	—	GHz	$V_{CE} = 5 V, I_C = 20 mA$ $f = 1 GHz$
S_{21} parameter	$ S_{21} ^2$	—	11.8	—	dB	$V_{CE} = 5 V, I_C = 20 mA$ $f = 1 GHz$
Power gain	PG	9.5	13	—	dB	$V_{CE} = 5 V, I_C = 20 mA$ $f = 900 MHz$
Noise figure	NF	—	1.1	1.9	dB	$V_{CE} = 5 V, I_C = 5 mA$ $f = 900 MHz$

Main Characteristics

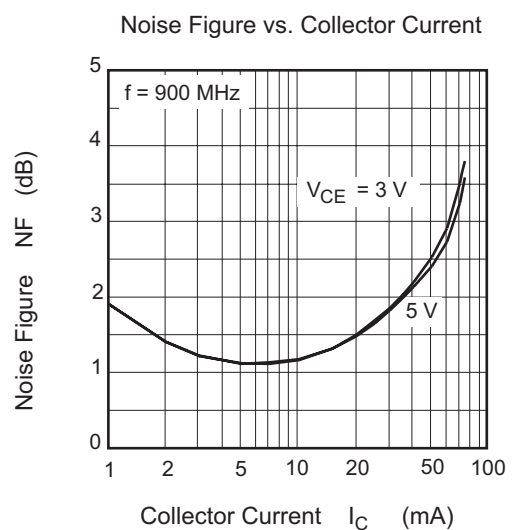
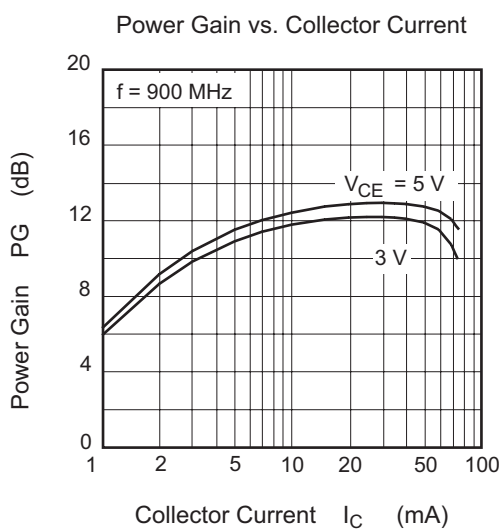
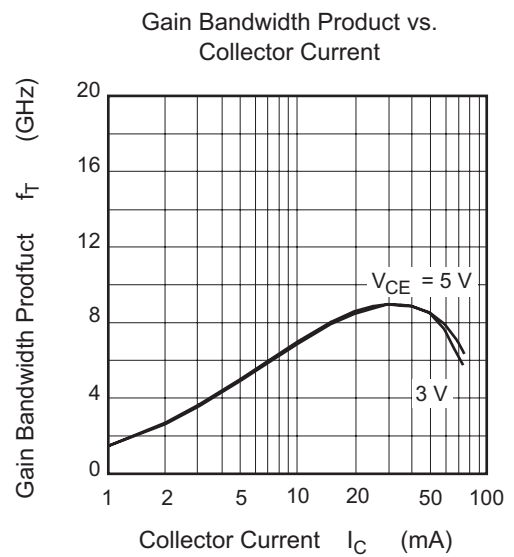
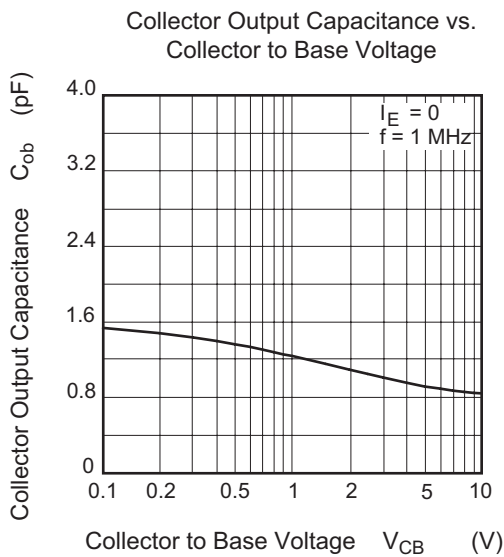
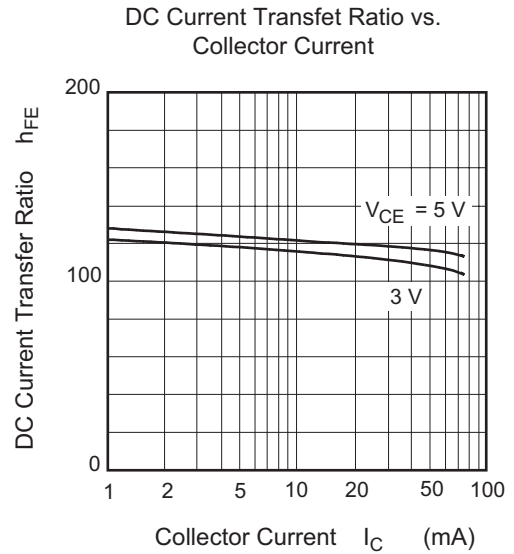
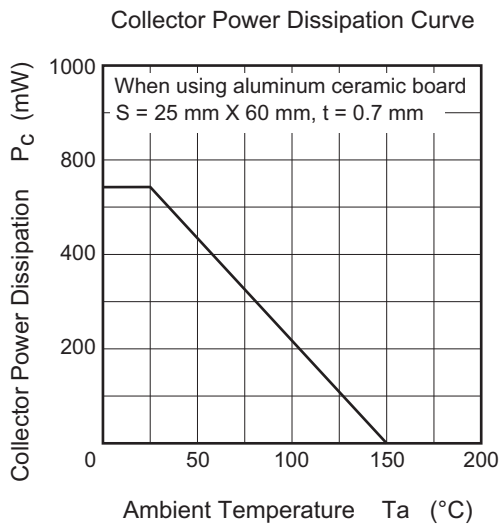

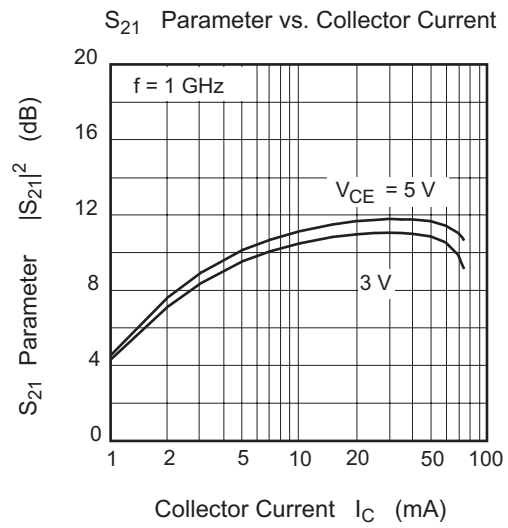

S11 Parameter vs. Frequency

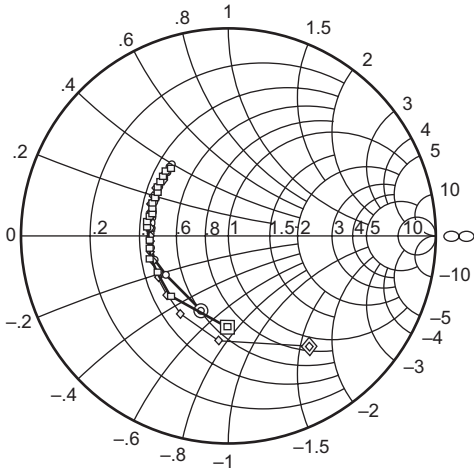

Condition: VCE = 3 V, ZO = 50 Ω
 100 to 2000 MHz (100 MHz Step)
 ○ (IC = 50 mA)
 □ (IC = 30 mA)
 ◇ (IC = 10 mA)

S21 Paramter vs. Frequency

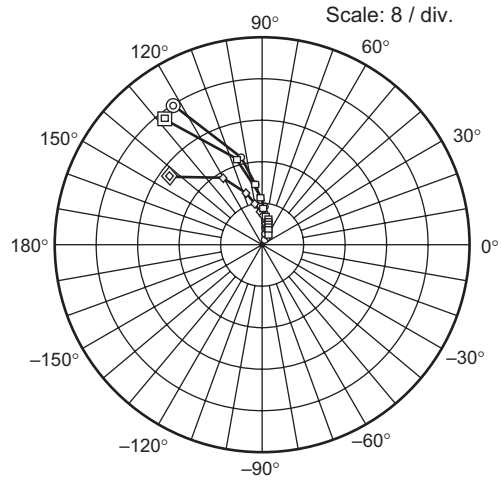

Condition: VCE = 3 V, ZO = 50 Ω
 100 to 2000 MHz (100 MHz Step)
 ○ (IC = 50 mA)
 □ (IC = 30 mA)
 ◇ (IC = 10 mA)

S12 Parameter vs. Frequency

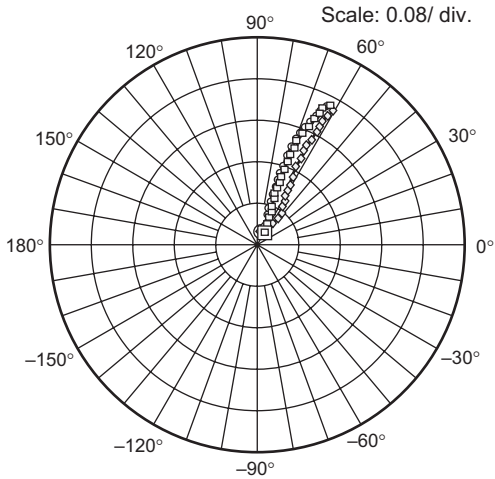

Condition: VCE = 3 V, ZO = 50 Ω
 100 to 2000 MHz (100 MHz Step)
 ○ (IC = 50 mA)
 □ (IC = 30 mA)
 ◇ (IC = 10 mA)

S22 Parameter vs. Frequency

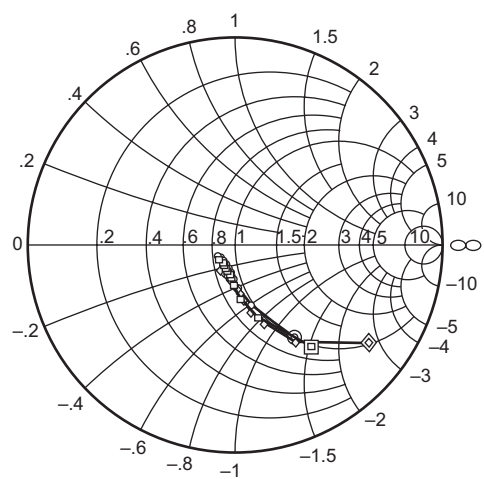

Condition: VCE = 3 V, ZO = 50 Ω
 100 to 2000 MHz (100 MHz Step)
 ○ (IC = 50 mA)
 □ (IC = 30 mA)
 ◇ (IC = 10 mA)

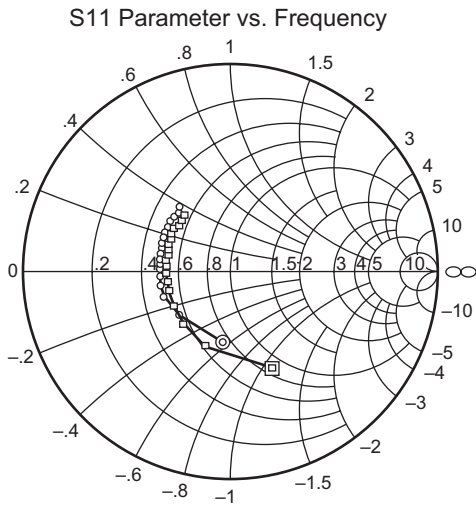

Condition: VCE = 5 V, ZO = 50 Ω
 100 to 2000 MHz (100 MHz Step)
 ○ (IC = 50 mA)
 □ (IC = 20 mA)

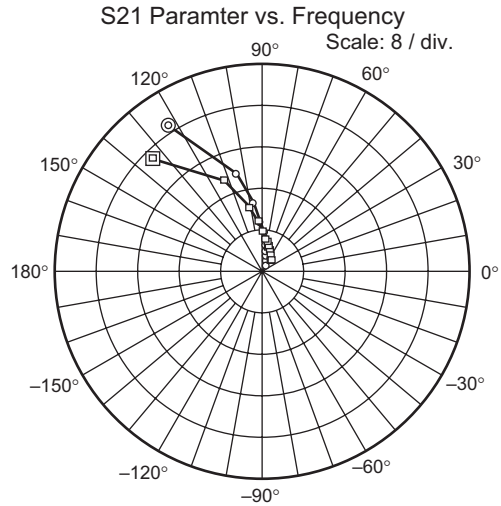

Condition: VCE = 5 V, ZO = 50 Ω
 100 to 2000 MHz (100 MHz Step)
 ○ (IC = 50 mA)
 □ (IC = 20 mA)

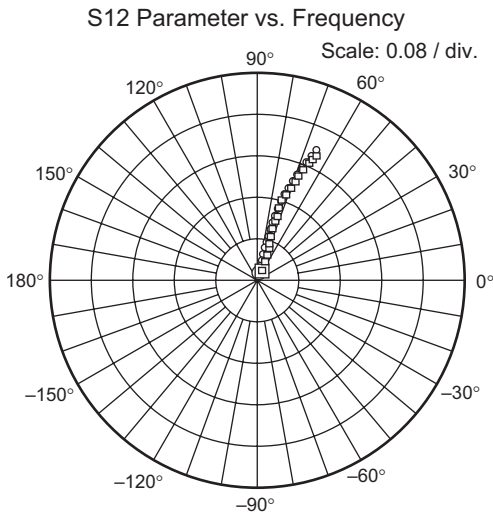

Condition: VCE = 5 V, ZO = 50 Ω
 100 to 2000 MHz (100 MHz Step)
 ○ (IC = 50 mA)
 □ (IC = 20 mA)

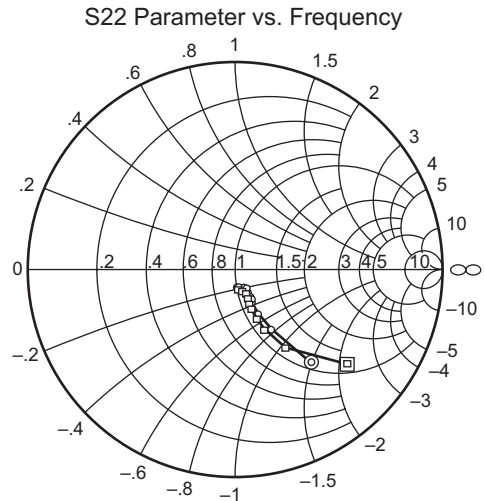

Condition: VCE = 5 V, ZO = 50 Ω
 100 to 2000 MHz (100 MHz Step)
 ○ (IC = 50 mA)
 □ (IC = 20 mA)

Sparameter

 $(V_{CE} = 3V, I_C = 10mA, Z_o = 50\Omega)$

f (MHz)	S11		S21		S12		S22	
	MAG	ANG	MAG	ANG	MAG	ANG	MAG	ANG
100	0.651	-53.8	21.22	142.8	0.035	65.6	0.802	-35.5
200	0.502	-93.8	14.62	120.0	0.054	56.9	0.554	-56.2
300	0.431	-119.6	10.48	107.6	0.067	56.0	0.401	-66.9
400	0.396	-136.4	8.09	99.8	0.079	56.9	0.317	-72.8
500	0.381	-149.9	6.57	94.2	0.091	58.9	0.263	-77.2
600	0.364	-158.7	5.54	89.7	0.103	60.3	0.227	-80.4
700	0.365	-167.2	4.78	85.9	0.116	61.6	0.201	-83.3
800	0.364	-174.6	4.22	82.5	0.128	62.5	0.183	-85.6
900	0.362	179.5	3.75	79.3	0.141	63.1	0.168	-88.3
1000	0.362	173.4	3.41	76.4	0.154	63.6	0.158	-90.2
1100	0.366	168.8	3.12	73.9	0.167	63.7	0.150	-92.7
1200	0.366	164.6	2.89	71.2	0.179	63.8	0.144	-95.0
1300	0.373	160.3	2.69	68.8	0.192	63.6	0.138	-97.0
1400	0.372	155.8	2.51	66.4	0.205	63.4	0.135	-99.0
1500	0.379	152.6	2.37	64.3	0.217	63.2	0.133	-101.7
1600	0.382	149.1	2.24	62.0	0.231	62.8	0.131	-103.7
1700	0.386	145.0	2.14	60.1	0.243	62.5	0.130	-106.0
1800	0.393	142.2	2.03	58.0	0.254	61.8	0.129	-108.2
1900	0.390	139.2	1.94	55.9	0.268	61.6	0.129	-110.5
2000	0.400	135.4	1.87	54.0	0.278	60.7	0.129	-112.1

$(V_{CE} = 3V, I_C = 30mA, Z_o = 50\Omega)$

f (MHz)	S11		S21		S12		S22	
	MAG	ANG	MAG	ANG	MAG	ANG	MAG	ANG
100	0.419	-90.2	30.42	127.3	0.026	63.9	0.608	-53.5
200	0.366	-132.9	17.49	107.6	0.040	64.4	0.357	-74.3
300	0.358	-151.9	11.80	98.6	0.055	67.0	0.247	-85.0
400	0.355	-163.8	8.88	93.1	0.070	69.5	0.193	-91.9
500	0.354	-173.3	7.14	89.0	0.085	70.6	0.162	-98.0
600	0.356	-178.8	5.97	85.5	0.100	71.5	0.141	-102.8
700	0.356	174.3	5.13	82.4	0.115	71.5	0.127	-107.4
800	0.364	169.5	4.51	79.6	0.130	71.4	0.117	-111.3
900	0.361	165.9	4.01	77.0	0.146	71.0	0.111	-114.9
1000	0.359	160.6	3.64	74.6	0.160	70.6	0.105	-118.5
1100	0.367	157.8	3.33	72.2	0.176	70.0	0.103	-121.5
1200	0.370	153.6	3.07	70.2	0.190	69.4	0.101	-124.5
1300	0.368	150.1	2.86	67.7	0.204	68.3	0.099	-127.0
1400	0.376	146.5	2.67	65.9	0.218	68.0	0.099	-129.3
1500	0.382	144.2	2.52	63.9	0.232	67.2	0.098	-131.8
1600	0.387	141.0	2.38	61.8	0.247	66.4	0.099	-133.9
1700	0.388	137.3	2.27	59.9	0.260	65.6	0.100	-135.8
1800	0.393	134.9	2.15	58.0	0.274	64.6	0.100	-138.0
1900	0.394	132.8	2.07	56.3	0.288	63.8	0.102	-139.9
2000	0.393	129.3	1.98	54.5	0.298	62.6	0.103	-140.6

$(V_{CE} = 3V, I_C = 50mA, Z_o = 50\Omega)$

f (MHz)	S11		S21		S12		S22	
	MAG	ANG	MAG	ANG	MAG	ANG	MAG	ANG
100	0.365	-111.0	31.77	122.3	0.023	65.4	0.530	-58.5
200	0.363	-147.7	17.40	104.2	0.037	68.1	0.299	-77.7
300	0.370	-162.8	11.60	96.2	0.052	71.0	0.207	-87.5
400	0.368	-172.3	8.71	91.0	0.068	72.8	0.163	-94.0
500	0.374	-179.4	6.97	87.3	0.083	73.4	0.137	-99.7
600	0.375	174.9	5.84	84.0	0.099	73.8	0.121	-104.7
700	0.378	170.4	5.02	81.2	0.114	73.6	0.110	-108.8
800	0.383	165.8	4.41	78.4	0.129	73.4	0.103	-112.5
900	0.381	161.7	3.91	76.0	0.146	72.7	0.099	-116.4
1000	0.384	157.4	3.55	73.3	0.161	72.4	0.095	-119.2
1100	0.389	153.7	3.25	71.2	0.177	71.6	0.093	-122.6
1200	0.394	150.4	3.00	69.0	0.190	70.7	0.092	-125.1
1300	0.395	147.3	2.80	66.7	0.204	69.7	0.091	-127.8
1400	0.398	144.1	2.61	64.8	0.219	69.2	0.092	-129.7
1500	0.407	141.7	2.46	62.9	0.233	68.2	0.092	-132.2
1600	0.410	139.0	2.33	60.8	0.248	67.4	0.093	-134.0
1700	0.407	135.2	2.21	59.0	0.262	66.5	0.095	-135.9
1800	0.414	133.5	2.10	57.2	0.275	65.5	0.096	-137.7
1900	0.412	130.3	2.02	55.0	0.289	64.8	0.098	-139.5
2000	0.423	127.6	1.93	53.1	0.300	63.6	0.099	-140.4

$(V_{CE} = 5V, I_C = 20mA, Z_o = 50\Omega)$

f (MHz)	S11		S21		S12		S22	
	MAG	ANG	MAG	ANG	MAG	ANG	MAG	ANG
100	0.505	-66.9	29.11	134.6	0.026	65.8	0.707	-40.5
200	0.381	-108.9	18.04	112.9	0.040	62.3	0.448	-57.3
300	0.337	-132.7	12.44	102.5	0.053	64.6	0.318	-63.3
400	0.320	-148.4	9.46	96.2	0.065	66.7	0.252	-65.8
500	0.311	-161.0	7.63	91.6	0.079	68.2	0.211	-67.2
600	0.305	-168.4	6.40	87.7	0.092	69.2	0.184	-67.9
700	0.308	-176.8	5.51	84.5	0.105	69.7	0.165	-68.5
800	0.306	177.7	4.84	81.4	0.119	70.1	0.152	-69.2
900	0.311	172.1	4.30	78.8	0.133	70.0	0.142	-70.5
1000	0.309	166.8	3.90	76.1	0.145	69.8	0.134	-71.1
1100	0.313	163.3	3.57	73.7	0.159	69.5	0.128	-72.7
1200	0.321	158.2	3.29	71.4	0.172	69.0	0.124	-74.2
1300	0.318	154.7	3.06	69.1	0.184	68.3	0.119	-75.5
1400	0.323	150.1	2.86	67.2	0.198	67.9	0.117	-77.2
1500	0.333	147.6	2.69	65.1	0.210	67.3	0.114	-79.1
1600	0.338	145.0	2.53	63.0	0.223	66.6	0.113	-80.9
1700	0.338	139.3	2.41	61.0	0.236	66.1	0.113	-83.2
1800	0.344	136.8	2.29	59.1	0.248	65.1	0.111	-85.5
1900	0.344	134.7	2.19	57.3	0.260	64.5	0.110	-88.0
2000	0.351	131.2	2.10	55.5	0.271	63.4	0.110	-89.6

$(V_{CE} = 5V, I_C = 50mA, Z_o = 50\Omega)$

f (MHz)	S11		S21		S12		S22	
	MAG	ANG	MAG	ANG	MAG	ANG	MAG	ANG
100	0.360	-99.4	34.20	124.3	0.020	66.9	0.567	-48.7
200	0.329	-139.8	19.03	105.6	0.034	68.2	0.330	-60.7
300	0.323	-157.8	12.76	97.1	0.047	71.6	0.233	-63.2
400	0.323	-168.1	9.58	92.1	0.061	73.6	0.186	-63.4
500	0.326	-176.6	7.69	88.2	0.075	74.1	0.160	-63.3
600	0.328	177.5	6.42	85.0	0.089	74.6	0.142	-63.4
700	0.326	172.1	5.51	82.0	0.103	74.4	0.131	-63.6
800	0.332	166.9	4.85	79.2	0.117	74.1	0.122	-63.9
900	0.335	163.3	4.30	76.9	0.131	73.6	0.116	-65.2
1000	0.336	159.3	3.90	74.3	0.145	73.3	0.112	-65.9
1100	0.338	155.0	3.56	72.2	0.158	72.4	0.108	-67.9
1200	0.349	151.7	3.28	69.9	0.172	72.0	0.106	-69.5
1300	0.347	148.8	3.05	67.9	0.185	71.0	0.103	-70.9
1400	0.350	144.3	2.85	65.9	0.198	70.4	0.102	-73.3
1500	0.360	142.0	2.67	64.0	0.210	69.7	0.101	-75.5
1600	0.362	139.2	2.52	62.1	0.224	68.7	0.101	-77.7
1700	0.361	135.3	2.40	60.1	0.237	67.9	0.101	-80.0
1800	0.373	133.4	2.28	58.1	0.249	66.9	0.101	-82.5
1900	0.366	130.6	2.19	56.3	0.262	66.2	0.101	-85.5
2000	0.383	127.4	2.10	54.6	0.272	65.2	0.102	-87.1

Package Dimensions

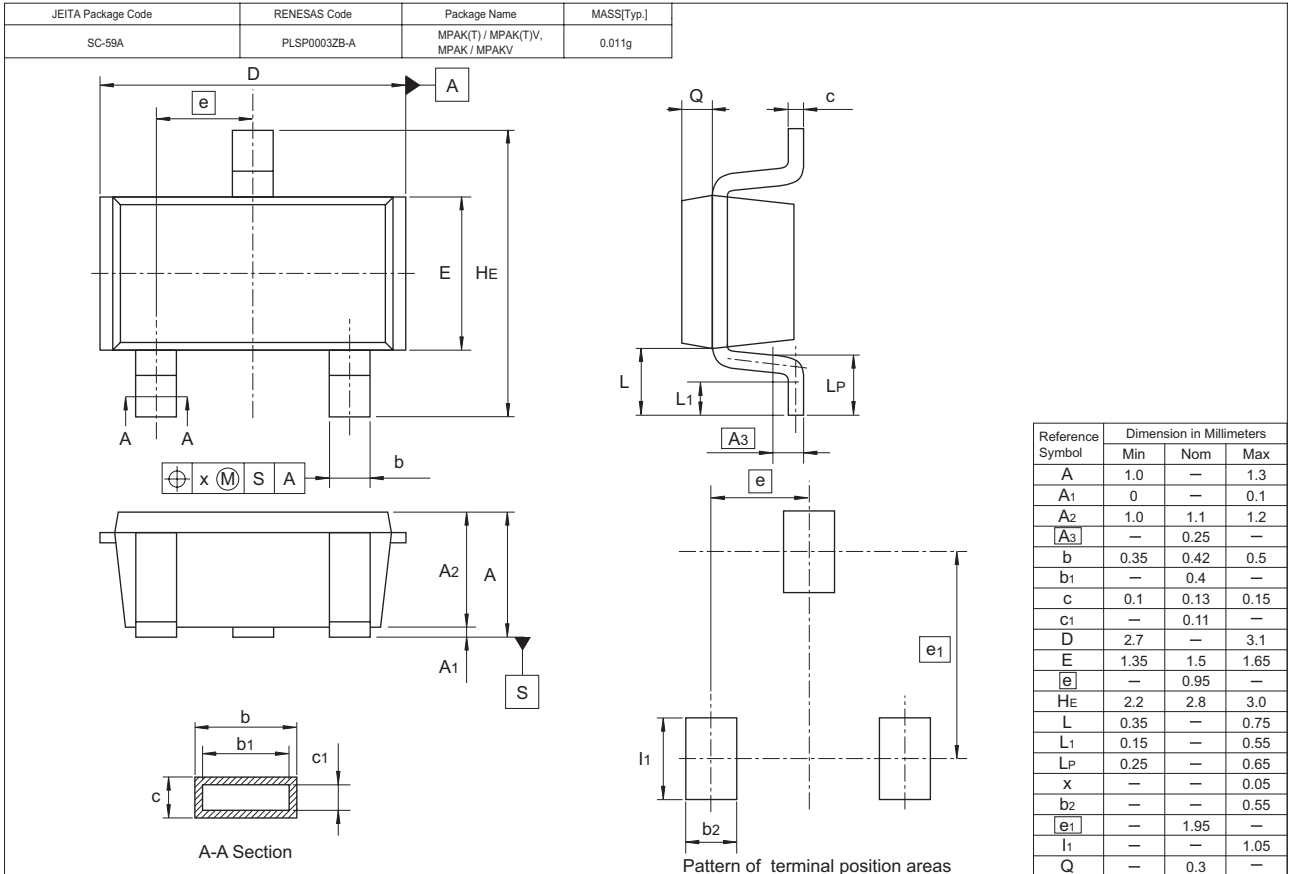

Ordering Information

Part Name	Quantity	Shipping Container
2SC5772FR-TL-E	3000	φ 178 mm Reel, 8 mm Emboss Taping

Note: For some grades, production may be terminated. Please contact the Renesas sales office to check the state of production before ordering the product.

Renesas Technology Corp. Sales Strategic Planning Div. Nippon Bldg., 2-6-2, Ohte-machi, Chiyoda-ku, Tokyo 100-0004, Japan

Keep safety first in your circuit designs!

1. Renesas Technology Corp. puts the maximum effort into making semiconductor products better and more reliable, but there is always the possibility that trouble may occur with them. Trouble with semiconductors may lead to personal injury, fire or property damage. Remember to give due consideration to safety when making your circuit designs, with appropriate measures such as (i) placement of substitutive, auxiliary circuits, (ii) use of nonflammable material or (iii) prevention against any malfunction or mishap.

Notes regarding these materials

1. These materials are intended as a reference to assist our customers in the selection of the Renesas Technology Corp. product best suited to the customer's application; they do not convey any license under any intellectual property rights, or any other rights, belonging to Renesas Technology Corp. or a third party.
2. Renesas Technology Corp. assumes no responsibility for any damage, or infringement of any third-party's rights, originating in the use of any product data, diagrams, charts, programs, algorithms, or circuit application examples contained in these materials.
3. All information contained in these materials, including product data, diagrams, charts, programs and algorithms represents information on products at the time of publication of these materials, and are subject to change by Renesas Technology Corp. without notice due to product improvements or other reasons. It is therefore recommended that customers contact Renesas Technology Corp. or an authorized Renesas Technology Corp. product distributor for the latest product information before purchasing a product listed herein.
The information described here may contain technical inaccuracies or typographical errors.
Renesas Technology Corp. assumes no responsibility for any damage, liability, or other loss rising from these inaccuracies or errors.
Please also pay attention to information published by Renesas Technology Corp. by various means, including the Renesas Technology Corp. Semiconductor home page (<http://www.renesas.com>).
4. When using any or all of the information contained in these materials, including product data, diagrams, charts, programs, and algorithms, please be sure to evaluate all information as a total system before making a final decision on the applicability of the information and products. Renesas Technology Corp. assumes no responsibility for any damage, liability or other loss resulting from the information contained herein.
5. Renesas Technology Corp. semiconductors are not designed or manufactured for use in a device or system that is used under circumstances in which human life is potentially at stake. Please contact Renesas Technology Corp. or an authorized Renesas Technology Corp. product distributor when considering the use of a product contained herein for any specific purposes, such as apparatus or systems for transportation, vehicular, medical, aerospace, nuclear, or undersea repeater use.
6. The prior written approval of Renesas Technology Corp. is necessary to reprint or reproduce in whole or in part these materials.
7. If these products or technologies are subject to the Japanese export control restrictions, they must be exported under a license from the Japanese government and cannot be imported into a country other than the approved destination.
Any diversion or reexport contrary to the export control laws and regulations of Japan and/or the country of destination is prohibited.
8. Please contact Renesas Technology Corp. for further details on these materials or the products contained therein.



RENESAS SALES OFFICES

<http://www.renesas.com>

Refer to "<http://www.renesas.com/en/network>" for the latest and detailed information.

Renesas Technology America, Inc.

450 Holger Way, San Jose, CA 95134-1368, U.S.A
Tel: <1> (408) 382-7500, Fax: <1> (408) 382-7501

Renesas Technology Europe Limited

Dukes Meadow, Millboard Road, Bourne End, Buckinghamshire, SL8 5FH, U.K.
Tel: <44> (1628) 585-100, Fax: <44> (1628) 585-900

Renesas Technology Hong Kong Ltd.

7th Floor, North Tower, World Finance Centre, Harbour City, 1 Canton Road, Tsimshatsui, Kowloon, Hong Kong
Tel: <852> 2265-6688, Fax: <852> 2730-6071

Renesas Technology Taiwan Co., Ltd.

10th Floor, No.99, Fushing North Road, Taipei, Taiwan
Tel: <886> (2) 2715-2888, Fax: <886> (2) 2713-2999

Renesas Technology (Shanghai) Co., Ltd.

Unit2607 Ruijing Building, No.205 Maoming Road (S), Shanghai 200020, China
Tel: <86> (21) 6472-1001, Fax: <86> (21) 6415-2952

Renesas Technology Singapore Pte. Ltd.

1 Harbour Front Avenue, #06-10, Keppel Bay Tower, Singapore 098632
Tel: <65> 6213-0200, Fax: <65> 6278-8001

Renesas Technology Korea Co., Ltd.

Kukje Center Bldg. 18th Fl., 191, 2-ka, Hangang-ro, Yongsan-ku, Seoul 140-702, Korea
Tel: <82> 2-796-3115, Fax: <82> 2-796-2145

Renesas Technology Malaysia Sdn. Bhd.

Unit 906, Block B, Menara Amcorp, Amcorp Trade Centre, No.18, Jalan Persiaran Barat, 46050 Petaling Jaya, Selangor Darul Ehsan, Malaysia
Tel: <603> 7955-9390, Fax: <603> 7955-9510