

Car radio DSP for advanced signal processing

Features

- Full software flexibility with two 24x24 bit DSP cores
- FM processing
- AM processing
- Dolby B noise reduction
- MP3 and C3 decoding
- Echo AND noise cancellation
- Audio processor
- Special sound effect processor
- Dual media processing
- RDS Filter, Demodulator & Decoder
- 4 + 1 channel ADC, 6 channel DAC CODEC
- IIC/SPI control busses
- SAI 6 channel serial audio interface
- SPDIF interface with sample rate converter
- Dual core external memory interface
- Debug interface
- On-chip PLL

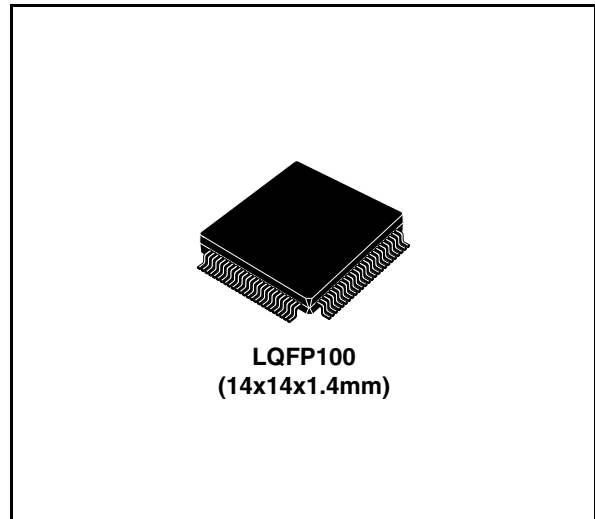

- 5V-tolerant 3V I/O interface
- Multifunction general purpose I/O ports

Description

The TDA7505 is an MPX-sampling DSP for car radio applications.

Table 1. Device summary

Order code	Package	Packing
TDA7505	LQFP100	Tray

Contents

1	Overview	6
2	Block diagram	7
3	Pin description	8
4	Electrical specifications	15
4.1	Absolute maximum ratings	15
4.2	Thermal data	15
4.3	Electrical characteristics	16
4.3.1	Recommended DC operating conditions	16
4.3.2	Power consumption	16
4.3.3	Oscillator characteristics	16
4.3.4	General interface electrical characteristics	17
4.3.5	High voltage CMOS interface DC electrical characteristics	17
4.3.6	DSP core	17
4.4	SAI interface timing - receiver	18
4.5	SAI interface timing - transmitter	18
4.6	SAI protocol	19
4.7	SPDIF receiver	19
4.8	SPI interfaces (Buffered SPI, Display SPI, RDS SPI)	20
4.9	I ² C Timing	21
4.10	DRAM/SRAM interface (EMI)	22
4.11	Debug port interface	22
5	Functional description	27
5.1	24-bit DSP core	27
5.2	DSP peripherals	28
5.2.1	Data and program memories	28
5.2.2	Serial audio interface (SAI)	29
5.2.3	Serial peripheral interface (SPI)	29
5.2.4	Sony/Philips digital interface (S/PDIF)	29
5.2.5	I2C interface	30

5.2.6	DRAM/SRAM interface (DEMI)	30
5.2.7	Debug interface	31
5.2.8	General purpose input/output	31
5.2.9	Asynchronous sample rate converter	31
5.2.10	SINCOS co-processor	31
5.2.11	PLL clock oscillator	31
5.2.12	CODEC	32
5.2.13	Radio data system (RDS)	32
5.2.14	Clock scheme	33
6	Software features	34
6.1	AM/FM base band signal processing	34
6.2	Generic audio signal processing	34
6.3	TAPE signal processing	34
6.4	CD signal processing	34
6.5	Audiophile	34
6.6	Audio decompression	34
6.7	Other	35
6.8	Functional modes	35
7	Package information	36
8	Revision history	37

List of tables

Table 1.	Device summary	1
Table 2.	Pin description	8
Table 3.	Absolute maximum ratings	15
Table 4.	Thermal data.	15
Table 5.	Recommended DC operating conditions	16
Table 6.	Power consumption	16
Table 7.	Oscillator characteristics.	16
Table 8.	General interface electrical characteristics	17
Table 9.	High voltage CMOS interface DC electrical characteristics	17
Table 10.	DSP core	17
Table 11.	SAI interface timing - receiver.	18
Table 12.	SAI interface timing - transmitter	19
Table 13.	SPDIF receiver	19
Table 14.	SPI interfaces	20
Table 15.	I ² C Timing.	21
Table 16.	DRAM timing.	22
Table 17.	DRAM refresh period	22
Table 18.	SRAM Timing	22
Table 19.	Debug port interface	22
Table 20.	ASRC	24
Table 21.	Fractional-N PLL.	24
Table 22.	ADC electrical characteristics - measurement bandwidth 10Hz to 20kHz	25
Table 23.	ADC electrical characteristics - measurement bandwidth 10Hz to 53kHz	25
Table 24.	ADC electrical characteristics - measurement bandwidth 10Hz to 192kHz	25
Table 25.	Level ADC electrical characteristics	25
Table 26.	DAC Performance.	26
Table 27.	FM stereo decoder (SW)	26
Table 28.	Examples of convenient clock schemes	33
Table 29.	Example of possible modes	35
Table 30.	Document revision history	37

List of figures

Figure 1.	Block diagram	7
Figure 2.	LQFP100 pins connection (top view)	14
Figure 3.	SAI interface timing - receiver.	18
Figure 4.	SAI interface timing - transmitter	18
Figure 5.	SAI protocol	19
Figure 6.	SPI interfaces	20
Figure 7.	SPI clocking scheme	21
Figure 8.	I ² C Timing	21
Figure 9.	Debug port serial clock timing.	23
Figure 10.	Debug port acknowledge timing	23
Figure 11.	Debug port data I/O to status timing	23
Figure 12.	Debug port read timing	24
Figure 13.	Debug port DBCK next command after read register timing.	24
Figure 14.	LQFP100 (14x14x1.4mm) mechanical data and package dimensions.	36

1 Overview

The TDA7505 integrates two 75 MIPS DSP cores. One core is used for stereo decoding, noise blanking, weak signal processing, Dolby B, music search and MP3 decoding. The second core is used for audio and sound processing and Echo & Noise cancellation. All functions are realized in SW and thus are flexible on customer request.

The device may be controlled by a main micro through either SPI or I²C interface. Through the same pins, but with separate device address (I²C) respectively separate chip select line (SPI) the main micro may communicate with the DSP or with the RDS block.

An additional SPI is available allowing a separate communication (e.g. to a display micro).

The DSP cores are integrated with their associated data and program memories.

DSP0 is declared as master. Its associated peripherals and interfaces are: I²C, SPI1 (Master SPI), SPI2 (Display SPI), Serial Audio Interface (SAI), PLL Oscillator, External Memory Interface (EMI), General Purpose I/O ports (DSP0 GPIO[0..11]), RDS filter and D/A converters.

DSP1 is declared as Co-DSP. Its associated peripherals and interfaces are: A/D converters, SPDIF, Sample Rate Converter (SRC) and General Purpose I/O ports (DSP1 GPIO[0..11]).

Both DSP's are identical (ST Orpheus core, 75 MHz clock). Only the peripherals and memory configurations are different. The internal communication takes place through a bi-directional 24/10-word exchange interface (XCHG) with complex flag and interrupts capability.

The Radio Data System (RDS, respectively RBDS) function is realized via dedicated hardware. It may run fully autonomous without SW intervention. Thus an efficient background mode as well as a low current standby mode is possible. The RDS input is connected to the A/D converter to receive the FM multiplex signal (MPX) automatically. Its output may be configured to I²C or SPI format. The pins are shared with the I²C and SPI1 of DSP0.

The device is equipped with a debug and test interface. It allows the SW development with a 100% compatible emulation system.

All functions, except RDS, are implemented in SW. Thus, the device may be adapted to customers' requirements. This implies the variable implementation of SW modules developed by the customer, ST and third parties. This flexibility also allows the usage for applications others than car radios, e.g.: Boosters.

2 Block diagram

Figure 1. Block diagram

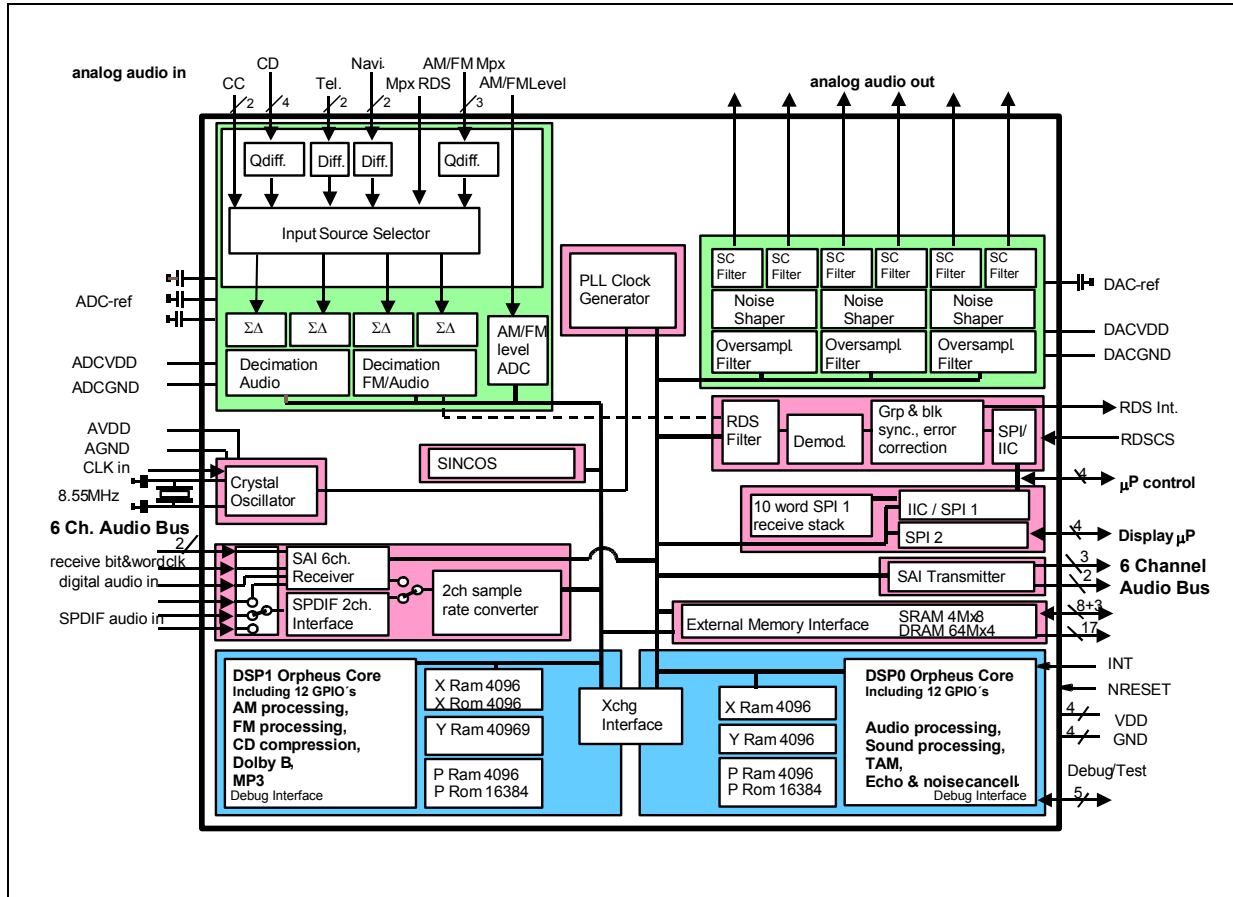

3 Pin description

Table 2. Pin description

N°	Name	Type	Function					
1	DAC4	A	Signal output D/A converter (single ended)					
2	DAC5	A	Signal output D/A converter (single ended)					
N°	Name	Type	Voltage		Function			
3	VDD1V8_1	S	1.8V		Digital Supply dedicated to internal logic			
4	GND1V8_1	S	0V		Digital Ground dedicated to internal logic			
N°	Name	Type	Reset state	After boot with			I/O	Function
				SPI	I ² C *	EMI		
5	NRESET	I	E0	E1	E1	E1	Input 5VT	System Reset. A low level applied to NRESET input initializes the IC.
6	SRCCD MISOD output MISOD input	I/O	Z	Z	Z	Z	Input 5VT Output 2mA PP/OD Input 5VT	SPDIF input source 1 (e.g.: CD) Display SPI SO (slave mode) Display SPI MI (master mode)
7	SRCMD MOSID input MOSID output DSP0 GPIO0 DSP0 GPIO0	I/O	Z	Z	Z	Z	Input 5VT Input 5VT Output 2mA PP Input 5VT Output 2mA PP	SPDIF input source 2 (e.g.: MD) Display SPI SI (slave mode) Display SPI MO (master mode) GPIO input GPIO output
8	SSD input INT DSP0 GPIO1 DSP0 GPIO1	I/O	Z	Z	Z	Z	Input 5VT Input 5VT Input 5VT Output 2mA PP	Display SPI SS slave select DSP0 external interrupt (IRQA) GPIO input GPIO output
9	CLKIN SCKD input SCKD output	I/O	Z	Z	Z	Z	Input 5VT Input 5VT Output 2mA PP	External clock input for PLL Display SPI clock (slave mode) Display SPI clock (master mode)
N°	Name	Type	Voltage		Function			
10	AVDD	S	3.3V		Supply dedicated to the PLL			
11	XTI	A	AC		Crystal oscillator input			
12	XTO	A	AC		Crystal oscillator output			
13	AGND	S	0V		Ground dedicated to the PLL			

Table 2. Pin description (continued)

N°	Name	Type	Reset State	After boot with			I/O	Function
				SPI	I ² C *	EMI		
14	RDSCS - DSP0 GPIO2 DSP0 GPIO2	I/O	Z	Z	Z	Z	Input 5VT Output 2mA OD Input 5VT Output 2mA PP	RDS SPI CS chip select in RDS bit data GPIO input GPIO output
15	INT - RDSINT DSP0 GPIO3 DSP0 GPIO3	I/O	Z	Z	Z	Z	Input 5VT Output 2mA OD Output 2mA PP Input 5VT Output 2mA PP	DSP0 external interrupt (IRQA) RDS bit clock RDS Interrupt Output GPIO input GPIO output
N°	Name	Type	Voltage			Function		
16	VDD3V3_1	S	3.3V			Digital supply dedicated to I/O structures		
17	GND3V3_1	S	0V			Digital ground dedicated to I/O structures		
18	SCKM input SCKM output SCL bi-direct DSP0 GPIO4 DSP0 GPIO4	I/O	Z	0/1	Z	Z	Input 5VT Output 2mA PP In 5VT/Out 2mA OD Input 5VT Output 2mA PP	Master/RDS SPI clock (slave m.) Master SPI clock (master mode) I ² C clock GPIO input GPIO output
N°	Name	Type	Reset state	After boot with			I/O	Function
				SPI	I ² C *	EMI		
19	MISOM output MISOM input ADDR select DSP0 GPIO5 DSP0 GPIO5	I/O	Z	0/1	Z	Z	Output 2mA PP/OD Input 5VT Input 5VT Input 5VT Output 2mA PP	Master/RDS SPI SO (slave m.) Master SPI MI (master mode) I ² C Address select line GPIO input GPIO output
20	MOSIM input MOSIM output SDA bi-direct DSP0 GPIO6 DSP0 GPIO6	I/O	Z	0/1	Z	Z	Input 5VT Output 2mA PP In 5VT/Out 2mA OD Input 5VT Output 2mA PP	Master/RDS SPI SI (slave m.) Master SPI MO (master mode) I ² C data GPIO input GPIO output
21	SSM input DSP0 GPIO7 DSP0 GPIO7	I/O	Z	Z	Z	Z	Input 5VT Input 5VT Output 2mA PP	Master SPI SS slave select GPIO input GPIO output
22	DSRA<0> DSRA<0>	I/O	0	1	1	Z	In/Out 2mA PP In/Out 2mA PP	EMI SRAM Data 0 EMI DRAM Data 0
23	DSRA<1> DSRA<1>	I/O	0	1	1	Z	In/Out 2mA PP In/Out 2mA PP	EMI SRAM Data 1 EMI DRAM Data 1
24	DSRA<2> DSRA<2>	I/O	0	1	1	Z	In/Out 2mA PP In/Out 2mA PP	EMI SRAM Data 2 EMI DRAM Data 2

Table 2. Pin description (continued)

N°	Name	Type	Reset state	After boot with			I/O	Function
				SPI	I ² C *	EMI		
25	DSRA<3> DSRA<3>	I/O	0	1	1	Z	In/Out 2mA PP In/Out 2mA PP	EMI SRAM Data 3 EMI DRAM Data 3
26	DSRA<4>	I/O	0	1	1	Z	In/Out 2mA PP	EMI SRAM Data 4
27	DSRA<5>	I/O	0	1	1	Z	In/Out 2mA PP	EMI SRAM Data 5
28	DSRA<6>	I/O	0	1	1	Z	In/Out 2mA PP	EMI SRAM Data 6
29	DSRA<7>	I/O	0	1	1	Z	In/Out 2mA PP	EMI SRAM Data 7
30	SRA<0> SRA<0>	O	0	1	1	0/1	Output 2mA PP Output 2mA PP	EMI SRAM Address 0 EMI DRAM Address 0
31	SRA<1> SRA<1>	O	0	1	1	0/1	Output 2mA PP Output 2mA PP	EMI SRAM Address 1 EMI DRAM Address 1
N°	Name	Type	Voltage			Function		
32	VDD3V3_2	S	3.3V			Digital Supply dedicated to I/O structures		
33	GND3V3_2	S	0V			Digital Ground dedicated to I/O structures		
N°	Name	Type	Reset state	After boot with			I/O	Function
				SPI	I ² C *	EMI		
34	SRA<2> SRA<2>	O	0	1	1	0/1	Output 2mA PP Output 2mA PP	EMI SRAM Address 2 EMI DRAM Address 2
35	SRA<3> SRA<3>	O	0	1	1	0/1	Output 2mA PP Output 2mA PP	EMI SRAM Address 3 EMI DRAM Address 3
36	SRA<4> SRA<4>	O	0	1	1	0/1	Output 2mA PP Output 2mA PP	EMI SRAM Address 4 EMI DRAM Address 4
37	SRA<5> SRA<5>	O	0	1	1	0/1	Output 2mA PP Output 2mA PP	EMI SRAM Address 5 EMI DRAM Address 5
38	SRA<6> SRA<6>	O	0	1	1	0/1	Output 2mA PP Output 2mA PP	EMI SRAM Address 6 EMI DRAM Address 6
39	SRA<7> SRA<7>	O	0	1	1	0/1	Output 2mA PP Output 2mA PP	EMI SRAM Address 7 EMI DRAM Address 7
40	SRA<8> SRA<8>	O	0	1	1	0/1	Output 2mA PP Output 2mA PP	EMI SRAM Address 8 EMI DRAM Address 8
N°	Name	Type	Reset state	After boot with			I/O	Function
				SPI	I ² C *	EMI		
41	SRA<9> SRA<9>	O	0	1	1	0/1	Output 2mA PP Output 2mA PP	EMI SRAM Address 9 EMI DRAM Address 9
42	SRA<10> SRA<10>	O	0	1	1	0/1	Output 2mA PP Output 2mA PP	EMI SRAM Address 10 EMI DRAM Address 10

Table 2. Pin description (continued)

N°	Name	Type	Reset state	After boot with			I/O	Function
				SPI	I ² C *	EMI		
43	SRA<11> SRA<11>	O	0	1	1	0/1	Output 2mA PP Output 2mA PP	EMI SRAM Address 11 EMI DRAM Address 11
44	SRA<12> SRA<12>	O	0	1	1	0/1	Output 2mA PP Output 2mA PP	EMI SRAM Address 12 EMI DRAM Address 12
N°	Name	Type	Voltage			Function		
45	VDD1V8_2	S	1.8V			Digital Supply dedicated to internal logic		
46	GND1V8_2 & GND3V3_3	S	0V			Digital Ground dedicated to internal logic and I/O structures		
47	VDD3V3_3	S	3.3V			Digital Supply dedicated to I/O structures		
N°	Name	Type	Reset state	After boot with			I/O	Function
				SPI	I ² C *	EMI		
48	DRD	O	1	1	1	1	Output 2mA PP	EMI data read strobe
49	DWR	O	1	1	1	1	Output 2mA PP	EMI data write strobe
50	CAS SRA<13>	O	0	1	1	0/1	Output 2mA PP Output 2mA PP	EMI DRAM CAS EMI SRAM Address 13
51	SRA<14>	O	0	1	1	0/1	Output 2mA PP	EMI SRAM Address 14
52	SRA<15> DSP0 GPIO8 DSP0 GPIO8	I/O	Z	Z	Z	0/1	Output 2mA PP Input 5VT Output 2mA PP	EMI SRAM Address 15 GPIO input GPIO output
53	INOUTA SRA<16> DSP1 GPIO0 DSP1 GPIO0	I/O	Z	Z	Z	0/1	In 5VT/Out 2mA PP Output 2mA PP Input 5VT Output 2mA PP	Multi function I/O EMI SRAM Address 16 GPIO input GPIO output
54	INOUTB SRA<17> DSP1 GPIO1 DSP1 GPIO1	I/O	Z	Z	Z	0/1	In 5VT/Out 2mA PP Output 2mA PP Input 5VT Output 2mA PP	Multi function I/O EMI SRAM Address 17 GPIO input GPIO output
55	INOUTC SRA<18> DSP1 GPIO2 DSP1 GPIO2	I/O	Z	Z	Z	0/1	In 5VT/Out 2mA PP Output 2mA PP Input 5VT Output 2mA PP	Multi function I/O EMI SRAM Address 18 GPIO input GPIO output
N°	Name	Type	Reset state	After boot with			I/O	Function
				SPI	I ² C *	EMI		
56	INOUTD SRA<19> DSP1 GPIO3 DSP1 GPIO3	I/O	Z	Z	Z	0/1	In 5VT/Out 2mA PP Output 2mA PP Input 5VT Output 2mA PP	Multi function I/O EMI SRAM Address 19 GPIO input GPIO output

Table 2. Pin description (continued)

N°	Name	Type	Reset state	After boot with			I/O	Function
				SPI	I ² C *	EMI		
57	INOUTE SRA<20> DSP1 GPIO4 DSP1 GPIO4	I/O	Z	Z	Z	0/1	In 5VT/Out 2mA PP Output 2mA PP Input 5VT Output 2mA PP	Multi function I/O EMI SRAM Address 20 GPIO input GPIO output
58	INOUTF SRA<21> RAS DSP1 GPIO5 DSP1 GPIO5	I/O	Z	Z	Z	0/1	In 5VT/Out 2mA PP Output 2mA PP Output 2mA PP Input 5VT Output 2mA PP	Multi function I/O EMI SRAM Address 21 EMI DRAM RAS GPIO input GPIO output
59	INOUTG DSP1 GPIO6 DSP1 GPIO6	I/O	Z	Z	Z	Z	In 5VT/Out 2mA PP Input 5VT Output 2mA PP	Multi function I/O GPIO input GPIO output
60	INOUTH DSP1 GPIO7 DSP1 GPIO7	I/O	Z	Z	Z	Z	In 5VT/Out 2mA PP Input 5VT Output 2mA PP	Multi function I/O GPIO input GPIO output
N°	Name	Type	Voltage			Function		
61	VDD3V3_4	S	3.3V			Digital Supply dedicated to I/O structures		
62	GND3V3_4	S	0V			Digital Ground dedicated to I/O structures		
N°	Name	Type	Reset state	After boot with			I/O	Function
				SPI	I ² C *	EMI		
63	INOUTI DSP1 GPIO8 DSP1 GPIO8	I/O	Z	Z	Z	Z	In 5VT/Out 2mA PP Input 5VT Output 2mA PP	Multi function I/O GPIO input GPIO output
64	INOUTJ	I/O	Z	Z	Z	Z	In 5VT/Out 2mA PP	Multi function I/O
65	DBCK OS1 DSP0/1 GPIO9 DSP0/1 GPIO9	I/O	Z	0	0	0	Input 5VT Out 2mA PP Input 5VT Output 2mA PP	Debug clock Chip status 1 GPIO input GPIO output
66	DBOUT DSP0/1 GPIO10 DSP0/1 GPIO10	I/O	Z	1	1	1	Output 2mA PP Input 5VT Output 2mA PP	Debug output GPIO input GPIO output
N°	Name	Type	Reset state	After boot with			I/O	Function
				SPI	I ² C *	EMI		
67	DBIN OS0 DSP0/1 GPIO11 DSP0/1 GPIO11	I/O	Z	0	0	0	Input 5VT Out 2mA PP Input 5VT Output 2mA PP	Debug input Chip status 0 GPIO input GPIO output

Table 2. Pin description (continued)

N°	Name	Type	Reset state	After boot with			I/O	Function
				SPI	I ² C *	EMI		
68	Debug/Test_Sel0	I	E1	E1	E1	E1	Input	Mode select (Debug0/1, Test)
69	Debug/Test_Sel1	I	E1	E1	E1	E1	Input	Mode select (Debug0/1, Test)
70	INOUTK	I/O	0	0	0	0	In 5VT/Out 2mA PP	Multi function I/O
N°	Name	Type	Voltage			Function		
71	VDD1V8_3	S	1.8V			Digital Supply dedicated to internal logic		
72	GNDSUB_D	S	0V			Digital substrate Ground		
N°	Name	Type	Function					
73	LEVEL_AM/FM	A	Signal input to level ADC (single ended)					
74	MPX_AM+	A	Signal input tuner AM (quasi differential)					
75	MPX_AM/FM-	A	Signal input tuner common ground (quasi differential)					
76	MPX_FM+	A	Signal input tuner FM (quasi differential)					
77	MPX_RDS	A	Signal input background tuner (for RDS) single ended					
78	Navi-	A	Signal input from navigation system (differential)					
79	Navi+	A	Signal input from navigation system (differential)					
80	Phone-	A	Signal input from Telephone (differential)					
81	Phone+	A	Signal input from Telephone (differential)					
N°	Name	Type	Voltage			Function		
82	ADCGND	S	0V			Analog Ground dedicated to the A/D converter		
83	ADCVDD	S	3.3V			Analog Supply dedicated to the A/D converter		
N°	Name	Type	Function					
84	ADCREF3	A	ADC reference voltage decoupling					
85	CD_R+	A	Signal right input from CD-changer (differential)					
86	CD_R-	A	Signal right input from CD-changer (differential)					
87	ADCREF2	A	ADC reference voltage decoupling					
88	CD_L-	A	Signal left input from CD-changer (differential)					
89	CD_L+	A	Signal left input from CD-changer (differential)					
90	ADCREF1	A	ADC reference voltage decoupling					
91	CC_R	A	Signal right input from cassette (single ended)					
92	CC_L	A	Signal left input from cassette (single ended)					
N°	Name	Type	Voltage			Function		
93	GNDSUB_A	S	0V			Analog substrate Ground		
94	DACVDD	S	3.3V			Analog Supply dedicated to the D/A converter.		

4 Electrical specifications

4.1 Absolute maximum ratings

Table 3. Absolute maximum ratings

Symbol	Parameter	Value	Unit
VDD1V8	Power supplies digital	-0.5 to +1.95	V
VDD3V3	I/O	-0.5 to +3.6	V
AVDD	Analog	-0.5 to +3.6 ⁽¹⁾	V
DACVDD	DAC	-0.5 to +3.6 ⁽¹⁾	V
ADCVDD	ADC	-0.5 to +3.6 ⁽¹⁾	V
	Analog input or output voltage	-0.5 to (AVDD+0.5) ⁽¹⁾	V
	Digital input or output voltage, 5V tolerant	Normal ⁽²⁾	-0.5 to 6.3
		Fail-safe ⁽³⁾	-0.5 to 3.8
T _{op}	Operating temperature range	-40 to 85	°C
T _{stg}	Storage temperature	-55 to 150	°C

1. The maximum difference in the voltage of AVDD, DACVDD, ADCVDD, analog inputs and analog outputs must not exceed 0.5V. Warning: Operation at or beyond these limits may result in permanent damage to the device. Normal operation is not guaranteed at these extremes.

2. During Normal Mode operation VDD3 is always available as specified.

3. During Fail-save Mode operation VDD3 may be not available.

4.2 Thermal data

Table 4. Thermal data

Symbol	Parameter	Value	Unit
R _{th j-amb}	Thermal resistance junction to ambient ⁽¹⁾	55	°C/W
T _j	Operating junction temperature	125	°C
R _{th j-case}	Thermal junction to case ⁽²⁾	10	°C/W

1. In still air

2. Measured on top side of the package

4.3 Electrical characteristics

4.3.1 Recommended DC operating conditions

Table 5. Recommended DC operating conditions

Symbol	Parameter	Test condition	Min.	Typ.	Max.	Unit
VDD1V8	Digital supply voltage		1.7	1.8	1.9	V
VDD3V3	I/O supply voltage		3.15	3.3	3.49	V
AVDD	Analog supply voltage		3.15	3.3	3.49	V
DACVDD	D/A supply voltage		3.15	3.3	3.49	V
ADCVDD	A/D supply voltage		3.15	3.3	3.49	V

4.3.2 Power consumption

Table 6. Power consumption

Symbol	Parameter	Test condition	Min.	Typ.	Max.	Unit
I _{dd}	Maximum current	Digital power supply @ 1.8V		195		mA
I _{dio}	Maximum current	Digital IO power supply @ 3.3V		6		mA
I _{DAC}	Maximum current	DAC analog power supply @ 3.3V		22		mA
I _{ADC}	Maximum current	ADC analog power supply @ 3.3V		43		mA

Note: 75MHz internal DSP clock, all CODEC channels enabled at T_{amb} = 25 °C

4.3.3 Oscillator characteristics

Table 7. Oscillator characteristics

Symbol	Parameter	Test condition	Min.	Typ.	Max.	Unit
F _{OSC}	Crystal oscillator frequency ⁽¹⁾			8.55		MHz
F _{EXT}	External oscillator frequency	connected through pin XTI ⁽¹⁾			75	MHz
F _{CLKIN}	External oscillator frequency	connected through pin CLKIN ⁽²⁾			80	MHz

1. RDS works only with 8.55Mhz quartz or alternative with 74.1MHz applied externally on XTI pin.
2. An alternative clock input (pin CLKIN) can be used for PLL to adjust the audio sampling rate. RDS can work in parallel with the 8.55MHz quartz.

4.3.4 General interface electrical characteristics

Table 8. General interface electrical characteristics

Symbol	Parameter	Test condition	Min.	Typ.	Max.	Unit
I_{il}	Low level input current without pull-up device	$V_i = 0V^{(1)}$			1	μA
I_{ih}	High level input current without pull-up device	$V_i = V_{DD3V3}^{(1)}$			1	μA
I_{oz}	Tri-state output leakage without pull up/down device	$V_o = 0V$ or $V_{DD3V3}^{(1)}$			1	μA
I_{ozFT}	5V tolerant tri-state output leakage without pull up/down device	$V_o = 0V$ or $V_{DD3V3}^{(1)}$			1	μA
		$V_o = 5.5V$		1	7	μA
$I_{latchup}$	I/O latch-up current	$V_i < 0V, V_i > V_{DD3V3}$	200			mA
V_{esd}	Electrostatic protection	Leakage, $1\mu A^{(2)}$	2000			V

1. The leakage currents are generally very small, $<1nA$. The value given here, 1 A, is a maximum that can occur after an electrostatic stress on the pin.
2. Human Body Model.

4.3.5 High voltage CMOS interface DC electrical characteristics

Table 9. High voltage CMOS interface DC electrical characteristics

Symbol	Parameter	Test condition	Min.	Typ.	Max.	Unit
V_{il}	Low Level Input Voltage	$3.0V < V_{DD3V3} < 3.6V$			$0.3 * V_{DD3V3}$	V
V_{ih}	High Level Input Voltage	$3.0V < V_{DD3V3} < 3.6V$	$0.5 * V_{DD3V3}$			V
V_{hyst}	Schmitt trigger hysteresis	$3.0V < V_{DD3V3} < 3.6V$	0.8			V
V_{ol}	Low level output Voltage	$I_{ol} = XmA^{(1),(2)}$			$0.1 * V_{DD3V3}$	V
V_{oh}	High level output Voltage		$0.89 * V_{DD3V3}$			V

1. Takes into account 200mV voltage drop in both supply lines.
2. X is the source/sink current under worst-case conditions and is depicted for every I/O or output pin in the pin description.

4.3.6 DSP core

Table 10. DSP core

Symbol	Parameter	Test condition	Min.	Typ.	Max.	Unit
F_{dsp}	DSP clock frequency			75		MHz
T_{res}	Reset signal low state duration			1		μs

4.4 SAI interface timing - receiver

Figure 3. SAI interface timing - receiver

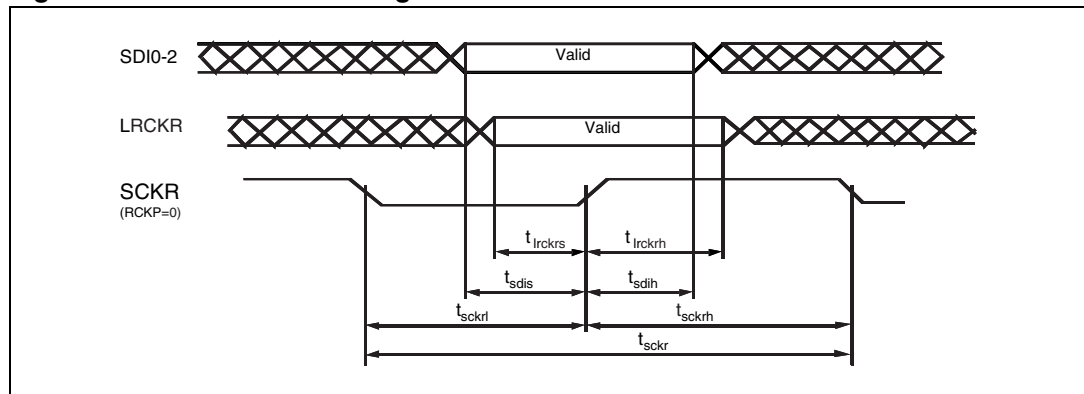

Table 11. SAI interface timing - receiver

Timing	Description	Min	Typ	Max	Unit
$T_{DSP}^{(1)}$	Internal DSP clock period (typical 1/75MHz)		13.33		ns
t_{sckr}	Minimum clock cycle	$6 T_{DSP}$			ns
t_{lrckrs}	LRCKR setup time	T_{DSP}			ns
t_{lrckrh}	LRCKR hold time	T_{DSP}			ns
t_{sdis}	SDI setup time	T_{DSP}			ns
t_{sdi}	SDI hold time	T_{DSP}			ns
t_{sckrh}	Minimum SCKR high time	$0.35 t_{sckr}$			ns
t_{sckrl}	Minimum SCKR low time	$0.35 t_{sckr}$			ns

1. T_{DSP} = DSP master clock cycle time = $1/F_{dsp}$

4.5 SAI interface timing - transmitter

Figure 4. SAI interface timing - transmitter

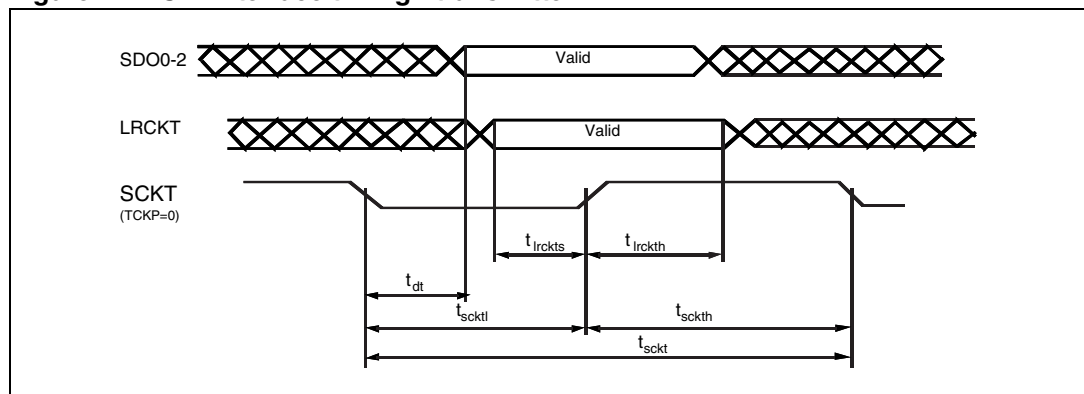

Table 12. SAI interface timing - transmitter

Timing	Description	Min	Typ	Max	Unit
$T_{DSP}^{(1)}$	Internal DSP clock period (typical 1/75MHz)		13.33		ns
t_{sckt}	Minimum clock cycle	$6 T_{DSP}$			ns
t_{lrckts}	LRCKT setup time	T_{DSP}			ns
t_{lrckth}	LRCKT hold time	T_{DSP}			ns
t_{dt}	SCKT active edge to data out valid	T_{DSP}			ns
t_{sckth}	Minimum SCKT high time	$0.35 t_{sckr}$			ns
t_{scktl}	Minimum SCKT low time	$0.35 t_{sckr}$			ns

1. T_{DSP} = DSP master clock cycle time = $1/F_{dsp}$

4.6 SAI protocol

Figure 5. SAI protocol

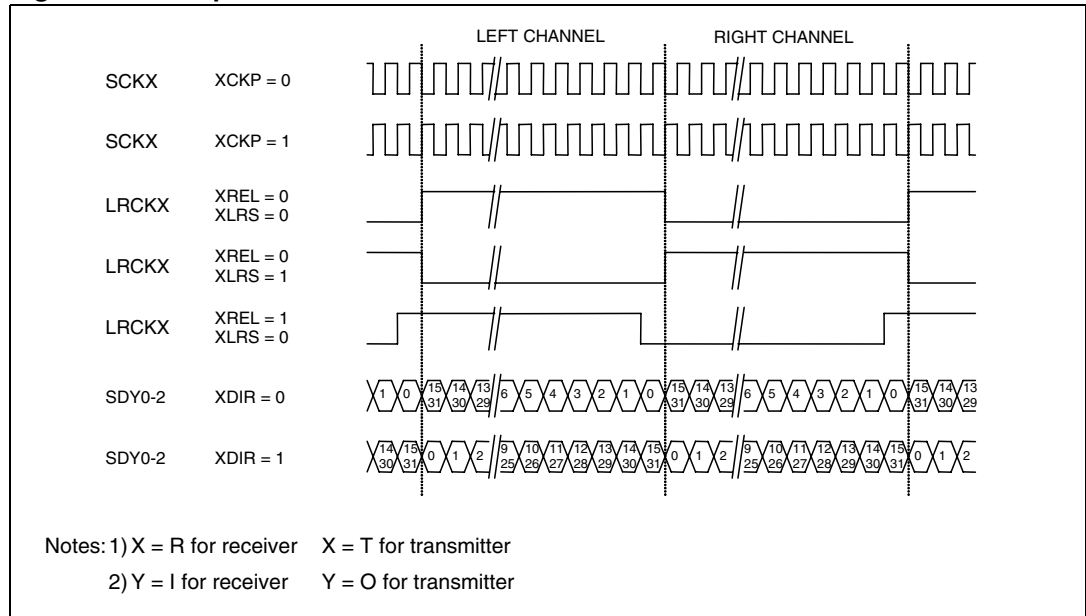

4.7 SPDIF receiver

Table 13. SPDIF receiver

Symbol	Parameter	Test condition	Min	Typ	Max	Unit
f_{spdif}	Input sampling rate	$F_{dsp} = 75 \text{ MHz}$	32		96	kHz
	Input precision with direct interface to DSP				24	bit
	Input precision with interface to ASRC				20	bit

4.8 SPI interfaces (Buffered SPI, Display SPI, RDS SPI)

Figure 6. SPI interfaces

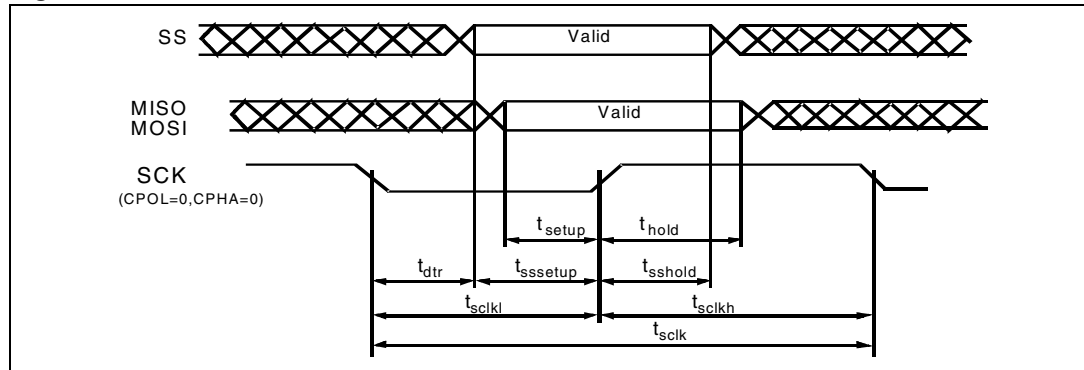
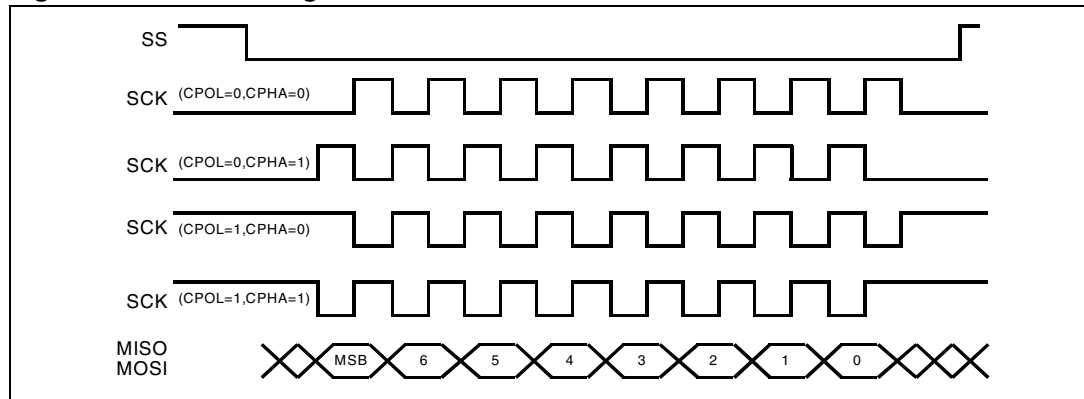

Table 14. SPI interfaces

Symbol	Description	Min	Typ	Max	Unit
T_{DSP}	Internal DSP clock period (typical 1/75MHz)		13.33		ns
Master mode					
t_{sclk}	Clock cycle	$12 T_{DSP}$			ns
t_{dtr}	SCK edge to MOSI valid	40			ns
t_{setup}	MISO setup time	16			ns
t_{hold}	MISO hold time	9			ns
t_{sckh}	SCK high time	$0.5 t_{sclk}$			ns
t_{sckl}	SCK low time	$0.5 t_{sclk}$			ns
$t_{sssetup}$	SS setup time	40			ns
t_{sshold}	SS hold time	25			ns
Slave mode					
t_{sclk}	Clock cycle	$12 T_{DSP}$			ns
t_{dtr}	SCK edge to MOSI valid	40			ns
t_{setup}	MOSI setup time	16			ns
t_{hold}	MOSI hold time	9			ns
t_{sckh}	SCK high time	$0.5 t_{sclk}$			ns
t_{sckl}	SCK high low	$0.5 t_{sclk}$			ns
$t_{sssetup}$	SS setup time	40			ns
t_{sshold}	SS hold time	20			ns

Figure 7. SPI clocking scheme



4.9 I²C Timing

Figure 8. I²C Timing

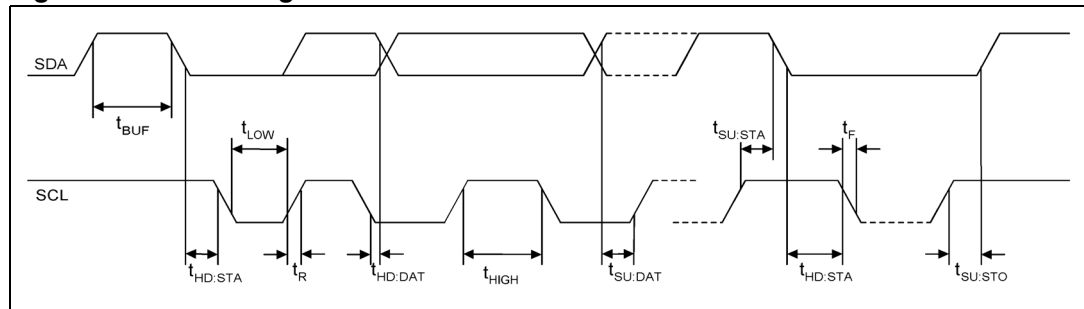

Table 15. I²C Timing

Symbol	Parameter	Test condition	Standard mode I ² C bus		Fast mode I ² C bus		Unit
			Min.	Max.	Min.	Max.	
F_{SCL}	SCL clock frequency		0	100	0	400	kHz
t_{BUF}	Bus free between a STOP and Start Condition		4.7	–	1.3	–	ms
$t_{HD:STA}$	Hold time (repeated) START condition. After this period, the first clock pulse is generated		4.0	–	0.6	–	ms
t_{LOW}	LOW period of the SCL clock		4.7	–	1.3	–	ms
t_{HIGH}	HIGH period of the SCL clock		4.0	–	0.6	–	ms
$t_{SU:STA}$	Set-up time for a repeated start condition		4.7	–	0.6	–	ms
$t_{HD:DAT}$	DATA hold time		0	–	0	0.9	ms
t_{R}	Rise time of both SDA and SCL signals	Cb in pF	–	1000	20+0.1Cb	300	ns

Table 15. I²C Timing (continued)

Symbol	Parameter	Test condition	Standard mode I ² C bus		Fast mode I ² C bus		Unit
			Min.	Max.	Min.	Max.	
t _F	Fall time of both SDA and SCL signals	C _b in pF	–	300	20+0.1Cb	300	ns
t _{SU;STO}	Set-up time for STOP condition		4	–	0.6	–	ms
t _{SU;DAT}	Data set-up time		250	–	100	–	ns
C _b	Capacitive load for each bus line		–	400	–	400	pF

4.10 DRAM/SRAM interface (EMI)

Table 16. DRAM timing

Symbol	Parameter	Test condition	Min.	Typ.	Max.	Unit
T _{acc0}	Fast DRAM access time	EDTM=0, 16 bit word		17		T _{dsp}
T _{acc0}	Fast DRAM access time	EDTM=0, 24 bit word		23		T _{dsp}
T _{acc1}	Slow DRAM access time	EDTM=1, 16 bit word		24		T _{dsp}
T _{acc1}	Slow DRAM access time	EDTM=1, 24 bit word		32		T _{dsp}

Table 17. DRAM refresh period

Symbol	Parameter	Test condition	Min.	Typ.	Max.	Unit
T _{ref}	DRAM refresh period		469		782	T _{dsp}

Table 18. SRAM Timing

Symbol	Parameter	Test condition	Min.	Typ.	Max.	Unit
T _{acc}	SRAM access time		2		9	T _{dsp}

4.11 Debug port interface

Table 19. Debug port interface

No.	Characteristics (F _{dsp} = 75MHz)	Min.	Max.	Unit
1	DBCK rise time		2	ns
2	DBCK fall time		2	ns
3	DBCK low	40		ns
4	DBCK high	40		ns
5	DBCK cycle time	200		ns
6	DBRQN asserted to DBOUT (ACK) asserted	5*T _{DSP}		ns
7	DBCK high to DBOUT valid		40	ns

Table 19. Debug port interface (continued)

No.	Characteristics (F _{dsp} = 75MHz)	Min.	Max.	Unit
8	DBCK high to DBOUT invalid	3		ns
9	DBIN valid to DBCK low (set-up)	15		ns
10	DBCK low to DBIN invalid (hold)	3		ns
	DBOUT (ACK) asserted to first DBCK high	2*T _{DSP}		ns
	DBOUT (ACK) assertion width	5*T _{DSP} - 3	5*T _{DSP} + 7	ns
11	Last DBCK low of read register to first DBCK high of next command	7*T _{DSP} + 10		ns
12	Last DBCK low to DBOUT invalid (hold)	3		ns
	DBSEL setup to DBCK	T _{DSP}		ns

Figure 9. Debug port serial clock timing

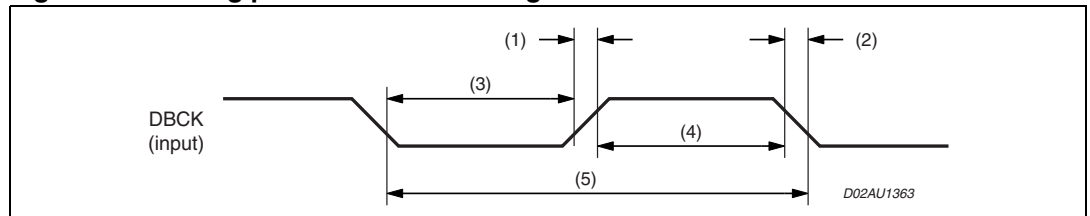

Figure 10. Debug port acknowledge timing

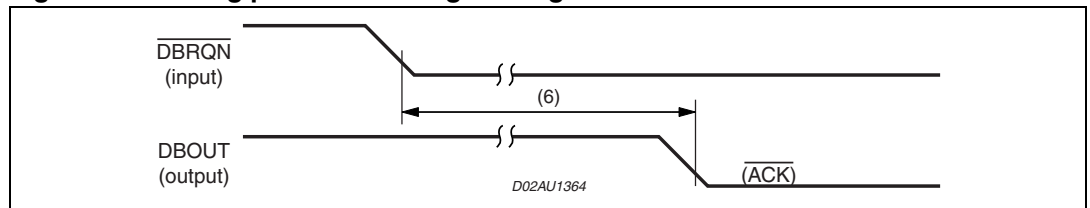

Figure 11. Debug port data I/O to status timing

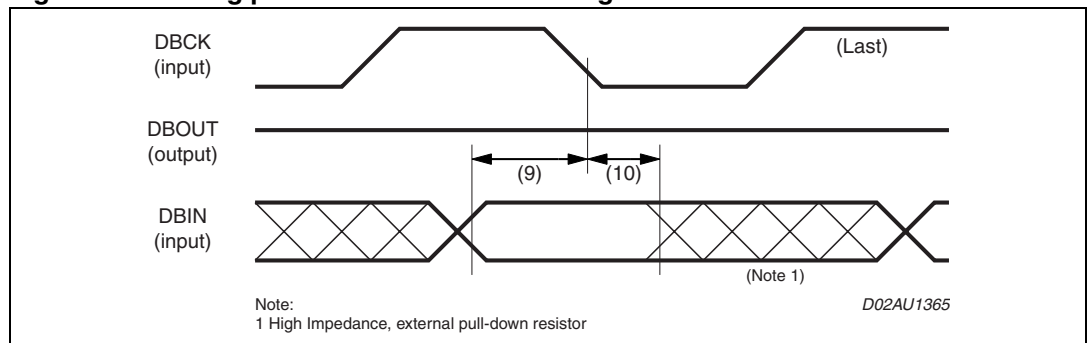

Figure 12. Debug port read timing

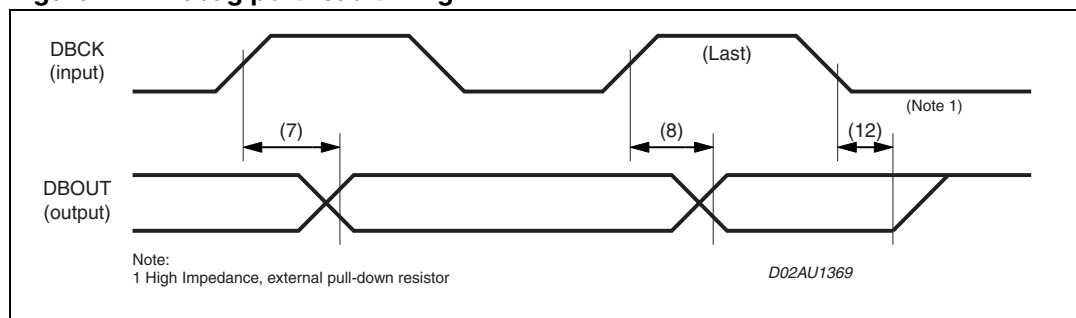

Figure 13. Debug port DBCK next command after read register timing

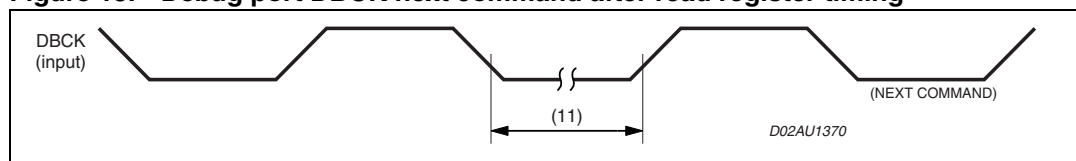

Table 20. ASRC

Symbol	Parameters	Test conditions	min	typ	max	Unit
THD+N	Total harmonic distortion + noise, unweighted, $F_{sin} / F_{sout} = 0.82$ (36 kHz → 44.1 kHz)	20 Hz–20 kHz, full scale, 16 bit inp.		-95		dB
		20 Hz–20 kHz, Full scale, 20 bit inp.		-98		dB
		1 kHz, full scale, 16 bit inp.		-95		dB
		15 kHz, full scale, 16 bit inp.		-95		dB
		1 kHz, full scale, 20 bit inp.		-105		dB
		15 kHz, full scale, 20 bit inp.		-98		dB
DR	Dynamic range, A-weighted, dithered input, $F_{sin} / F_{sout} = 0.82$ (36 kHz → 44.1 kHz)	1 kHz, -60 dB, 16 bit inp.		98		dB
		1 kHz, -60 dB, 16 bit inp.		120		dB
IPD	Interchannel phase deviation				0	deg
	Input sample rate range	No input signal decimation	32		48	kHz
	Input sample rate	Input signal decimation by 2		96		kHz
	Output sample rate range		32		48	kHz
Digital filter						
f_p	Passband Frequency			0.4110		F_{sin}
R_p	Passband Ripple	0–0.4110 F_{sin}	-0.01		+0.01	dB
f_s	Stopband Corner Frequency			0.5510		F_{sin}
R_s	Stopband Attenuation	@ f_s		-120		dB

Table 21. Fractional-N PLL

Symbol	Parameter	Test condition	Min.	Typ.	Max.	Unit
f_{VCO}	VCO output frequency		130		310	MHz

Table 22. ADC electrical characteristics - measurement bandwidth 10Hz to 20kHz
($T_{amb} = 25^{\circ}\text{C}$, $\text{ADCVDD} = 3.3\text{V}$, A-weighted filter.)

Symbol	Parameter	Test condition	Min.	Typ.	Max.	Unit
V_{in}	Input voltage dynamic range	Single ended mode Differential mode	0.5 1			Vrms
f_s	Sampling rate	Audio mode			48	kHz
DR ⁽¹⁾	Dynamic range	-60dB analog input	84	88		dB
SNR	Signal to noise ratio	1kHz; -3dB analog input	84	88		dB
THD+N	Total harmonic distortion + noise	1kHz; -3dB analog input		-85	-80	dB
R_i	Input impedance	@ $f_s = 44.1\text{kHz}$	45	80		k Ω
ICL ⁽²⁾	Interchannel isolation	Full scale input @ 1kHz		-95		dB

1. The specified value is obtained by adding 60dB to THD+N measure @ full scale -60dB
2. ICL can be influenced by external anti alias filter

Table 23. ADC electrical characteristics - measurement bandwidth 10Hz to 53kHz
($T_{amb} = 25^{\circ}\text{C}$, $\text{ADCVDD} = 3.3\text{V}$)

Symbol	Parameter	Test condition	Min.	Typ.	Max.	Unit
V_{in}	Input voltage dynamic range		0.5			Vrms
f_s	Sampling rate	FM-mode			192	kHz
DR ⁽¹⁾	Dynamic range	-60dB analog input	80			dB
SNR	Signal to noise ratio	1kHz; -3dB analog input	80			dB
THD+N	Total harmonic distortion + noise	1kHz; -3dB analog input			-80	dB

1. The specified value is obtained by adding 60dB to THD+N measure @ full scale -60dB

Table 24. ADC electrical characteristics - measurement bandwidth 10Hz to 192kHz
($T_{amb} = 25^{\circ}\text{C}$, $\text{AVDD} = 3.3\text{V}$)

Symbol	Parameter	Test condition	Min.	Typ.	Max.	Unit
V_{in}	Input voltage dynamic range		0.5			Vrms
f_s	Sampling rate	FM-mode for spike and RDS			384	kHz
DR ⁽¹⁾	Dynamic range	-60dB analog input	60			dB
SNR	Signal to noise ratio	1kHz; -3dB analog input	60			dB

1. The specified value is obtained by adding 60dB to THD+N measure @ full scale -60dB

Table 25. Level ADC electrical characteristics
($T_{amb} = 25^{\circ}\text{C}$, $\text{AVDD} = 3.3\text{V}$)

Symbol	Parameter	Test condition	Min.	Typ.	Max.	Unit
V_{in}	Input voltage range		0		2.5	V
THD	Total harmonic distortion			-57		dB
THD+N	Total harmonic distortion + noise			-46		dB
SNR	Signal to noise ratio			46		dB

Table 26. DAC Performance(T_{amb} = 25°C, DACVDD = 3.3V, measurement bandwidth 10Hz to 20kHz)

Symbol	Parameter	Test condition	Min.	Typ.	Max.	Unit
THD+N	Total harmonic distortion + noise	1kHz; -1dBFS, flat		-90		dB
THD	Total harmonic distortion	1kHz; -1dBFS, flat		-90		dB
SNR	Signal to noise ratio	1kHz; IEC61606 A-weighted RMS		100		dB
DR ⁽¹⁾	Dynamic range	1kHz; -60dBFS; IEC61606 A-weighted RMS		100		dB
NF ⁽²⁾	Noise floor	IEC61606 A-weighted RMS		-100		dBV
ICL	Interchannel isolation	1kHz; 0dBFS		-90		dB
Xtlk	Crosstalk	1kHz; 0dBFS		-90		dB
IGM	Interchannel gain mismatch	1kHz; 0dBFS		0.1		dB

1. The specified value is obtained by adding 60dB to THD+N measure @ full scale -60dB
2. With 00h input

Table 27. FM stereo decoder (SW)(T_{amb} = 25°C, ADCVDD = 3.3V, measurement bandwidth 10Hz to 20kHz, A-Weighted Filter.)

Symbol	Parameter	Test condition	Min.	Typ.	Max.	Unit
a_ch	Channel separation			>40		dB
(THD+N)	Total harmonic distortion	-3dB analog input		-80		dB
SNR	Signal to noise ratio	1kHz; -3dB analog input; mono		86		dB

5 Functional description

The TDA7505 is broken up into three distinct blocks. One block contains the two DSP Cores and their associated peripherals. The second contains the analog modules ADC with input multiplexer and level adjust and the DAC. The third module contains the RDS processing: filter, demodulator, decoder with error correction and the I²C/SPI interface with data buffer and interrupts output.

5.1 24-bit DSP core

The two DSP cores are used to process the audio and FM/AM data, coming from the ADC, or any kind of digital data coming via SPDIF or SAI. After the digital signal processing these data are sent to the DAC for analog conversion. Functions such as volume, tone, balance, and fader control, as well as spatial enhancement and general purpose signal processing may be performed by the DSP0. When FM/AM mode is selected, DSP1 is fully devoted to AM/FM processing. Nevertheless it can be used for any kind of different application, when a different input source is selected. Some capabilities of the DSPs are listed below:

- Single cycle multiply and accumulate with convergent rounding and condition code generation
- 2 x 56-bit Accumulators
- Double precision multiply
- Scaling and saturation arithmetic
- 48-bit or 2 x 24-bit parallel moves
- 64 interrupt vector locations
- Fast or long interrupts possible
- Programmable interrupt priorities and masking
- Repeat instruction and zero overhead DO loops
- Hardware stack capable of nesting combinations of 7 DO loops or 15 interrupts/subroutines
- Bit manipulation instructions possible on all registers and memory locations, also Jump on bit test
- 4 pin serial debug interface
- Debug access to all internal registers, buses and memory locations
- 5 word deep program address history FIFO
- Hardware and software breakpoints for both program and data memory accesses
- Debug Single stepping, Instruction injection and Disassembly of program memory

5.2 DSP peripherals

There are a number of peripherals that are tightly coupled to the two DSP Cores. Some of the peripherals are connected to DSP 0 others are connected to DSP 1.

- 4k x 24-Bit Program RAM for DSP0
- 16k x 24-Bit mask programmable Program ROM for DSP0
- 4k x 24-Bit X-Data RAM for DSP0
- 4k x 24-Bit Y-Data RAM for DSP0
- 4k x 24-Bit Program RAM for DSP1
- 16k x 24-Bit mask programmable Program ROM for DSP1
- 4k x 24-Bit X-Data RAM for DSP1
- 4k x 24-Bit mask programmable X-Data ROM for DSP1
- 4k x 24-Bit Y-Data RAM for DSP1
- 6 channel Serial Audio Interface (SAI)
- 2 channel SPDIF receiver with sampling rate conversion
- I²C and SPI interfaces
- XCHG Interface for DSP to DSP communication
- External Memory Interface (DRAM/SRAM) for time-delay and traffic information
- Debug Port for both DSP's
- General-purpose Input/Output lines
- Asynchronous Sample Rate Converter
- SINCOS co-processor
- PLL Clock Oscillator
- ADC's, ADC input multiplexer and DAC's (see [Section 5.2.12: CODEC on page 32](#))

5.2.1 Data and program memories

Both DSP0 and DSP1 have data and program memories attached to them. Each memory type is described below:

X-RAM

This is a 24-Bit Single Port SRAM used for storing coefficients. The 16-Bit XRAM address, XABx(15:0) is generated by the Address Generation Unit of the DSP core. The 24-Bit XRAM Data, XDBx(23:0), may be written to and read from the Data ALU of the DSP core.

X-ROM

This is a 24-Bit Single Port mask programmable ROM used for storing coefficients. The 16-Bit XRAM address, XABx(15:0) is generated by the Address Generation Unit of the DSP core. The 24-Bit XRAM Data, XDBx(23:0), may be read from the Data ALU of the DSP core.

Y-RAM

This is a 24-Bit Single Port SRAM used for storing coefficients. The 16-Bit address, YABx(15:0) is generated by the Address Generation Unit of the DSP core. The 24-Bit Data, YDBx(23:0), is written to and read from the Data ALU of the DSP core.

Program RAM

This is a 24-Bit Single Port SRAM used for storing and executing program code. The 16-Bit PRAM Address, PABx(15:0) is generated by the Program Address Generator of the DSP core for Instruction Fetching, and by the AGU in the case of the Move Program Memory (MOVEM) Instruction. The 24-Bit PRAM Data (Program Code), PDBx(23:0), can only be written to using the MOVEM instruction. During instruction fetching the PDBx Bus is routed to the Program Decode Controller of the DSP core for instruction decoding.

Program ROM

This is a 24-Bit Single Port mask programmable ROM used for storing and executing program code. Additionally the boot loader SW is placed here. Essentially this consists of reading the data via I2C, SPI or EMI interface and store it in PRAM, XRAM and YRAM. The 16-Bit PROM Address, PABx(15:0) is generated by the Program Address Generator of the DSP core for Instruction Fetching, and by the AGU in the case of the Move Program Memory (MOVEM) Instruction. The 24-Bit PROM Data (Program Code), PDBx(23:0), can only be read but not written. During instruction fetching the PDBx Bus is routed to the Program Decode Controller of the DSP core for instruction decoding.

5.2.2 Serial audio interface (SAI)

The SAI is used to deliver digital audio to the device from an external source. Once processed by the device, either it can be returned through this interface or sent to the DAC for D/A conversion. The features of the SAI are listed below:

- 3 Synchronized Stereo Data Transmission Lines
- 3 Synchronized Stereo Data Reception Lines
- Master and Slave operating mode: clock lines can be both master and slave.
- Receive and Transmit Data Registers have two locations to hold left and right data.

5.2.3 Serial peripheral interface (SPI)

The DSP core requires a serial interface to receive commands and data over the LAN. During an SPI transfer, data are transmitted and received simultaneously. A serial clock line synchronizes shifting and sampling of the information on the two serial data lines. A slave select line allows individual selection of a slave SPI device.

When an SPI transfer occurs an 8-bit word is shifted out through one data pin while another 8-bit word is simultaneously shifted in through a second data pin. The central elements in the SPI system are the shift register and the read data buffer. The system is single buffered in the transfer direction and has a 10 word buffer in the receive direction (only master SPI; the display SPI is single word buffered only).

5.2.4 Sony/Phillips digital interface (S/PDIF)

The S/PDIF receiver is a serial digital audio interface. It receives and decodes serial audio data according to one of the following standards: AES/EBU, IEC 958, S/PDIF, and EIAJ CP-340 in a frequency range from 32kHz up to 96kHz. The transfer protocol provides two audio data channels.

There is a direct output connected to Asynchronous Sample Rate Converter. Left and right 20 bit audio-channels and sample clock are provided.

5.2.5 I²C interface

The Inter Integrated Circuit bus is a single bidirectional two-wire bus used for efficient inter IC control. The device is compliant with the I²C specification including the high speed (400 kHz) mode.

Every component hooked up to the I²C bus has its own unique address whether it is a CPU, memory or some other complex function chip. Each of these chips can act as a receiver and/or transmitter on its functionality.

The device may act as master or as slave.

XCHG interface (DSP to DSP exchange interface)

The Exchange Interface peripheral provides bidirectional communication between DSP0 and DSP1. Both 24 bit word data and four bit Flag data can be exchanged. A FIFO is utilized for received data. It minimizes the number of times an Exchange Interrupt Service Routine would have to be called if multi-word blocks of data were to be received. The Transmit FIFO is in effect the Receive FIFO of the other DSP and is written directly by the transmitting DSP. The features of the XCHG are listed below:

- 10 Word XCHG FIFO on DSP0 to transfer data to DSP1
- 24 Word XCHG FIFO on DSP1 to transfer data to DSP0
- Four Flags for each XCHG for DSP to DSP signaling
- Condition flags can optionally trigger interrupts on both DSP's

5.2.6 DRAM/SRAM interface (DEMI)

The External DRAM/SRAM Interface is viewed as a memory mapped peripheral of both DSP cores. Data transfers are performed by moving data into/from data registers. The control is exercised by polling status flags in the control/status register or by servicing interrupts. This can be done by both DSP cores.

The features of the DEMI (Dual core Extended Memory Interface) are listed below:

- Data bus width fixed at 4 bits for DRAM and 8 bits for SRAM
- Data word length 16 or 24 bits for DRAM
- Data word length 8 or 16 or 24 bits for SRAM
- 13 DRAM address lines means $2^{26} = 256\text{M}$ bit addressable DRAM
- Refresh rate for DRAM can be chosen among eight divider factors
- SRAM relative addressing mode; $2^{22} = 32\text{M}$ bit addressable SRAM
- Four SRAM Timing choices
- Two Read Offset Registers

5.2.7 Debug interface

A multiplexed Debug Port is available for the DSP Cores. The debug logic is contained in the core design of the DSP. The features of the Debug Port are listed below:

- Breakpoint Logic
- Trace Logic
- Single stepping
- Instruction Injection
- Program Disassembly

5.2.8 General purpose input/output

The DSP requires a set of external general purpose input/output lines, and a reset line. These signals are used by external devices to signal events to the DSP. The GPIO lines are implemented as DSP 's peripherals. The GPIO lines are grouped in Port A, connected to DSP 0, and Port B, connected to DSP1.

5.2.9 Asynchronous sample rate converter

The ASRC, embedded in the device, offers a fully digital stereo asynchronous sample rate conversion of digital audio sources to the device's internal sample frequency. This solves the problem of mixing audio sources with different sample rates.

The ASRC is able to do both up- and down-sampling. There is no need to explicitly program the input and output sample rates, as the ASRC solves this problem with an automatic Digital Ratio Locked Loop.

In case of down sampling, an internal low pass filter limits the bandwidth. Thus any down folding products are avoided.

The ASRC is intended for applications up to 20 bit input word width. Digital Audio Sources can be applied in general Serial Audio Interface format (3 wires) as well as in AES/EBU, IEC 958, S/PDIF and EIAJ CP-340 format (1 wire).

An interface to the DSP core offers the possibility of interrupt controlled sample delivery. Furthermore, a programmable Control/Status Register inside the ASRC allows a great variety of adjustments and status information.

The ASRC is intended for applications

- up to 20 bit input and 24 bit output word width,
- 32kHz to 96kHz sample rate for input signal (SPDIF Receiver features)
- 32kHz to 48kHz sample rate for output signal.

5.2.10 SINCOS co-processor

The SINCOS is a cordic-based co-processor for calculation of sine and cosine without using DSP resources.

5.2.11 PLL clock oscillator

The PLL Clock Oscillator can accept an external clock at CLKIN or it can be configured to run with an internal oscillator when a crystal is connected across pins XTI & XTO. There is an input divide block IDF (1 -> 32) at the XTI clock input and a multiply block MF (9 -> 128)

in the PLL loop. Hence the PLL can multiply the external input clock by a ratio MF/IDF to generate the internal clock. This allows the internal clock to be within 1 MHz of any desired frequency even when XTI is much greater than 1 MHz. It is recommended that the input clock is not divided down to less than 1 MHz as this reduces the Phase Detector's update rate.

The clocks to the DSP can be selected to be either the VCO output divided by 2 to 16, or be driven by the XTI pin directly.

The crystal oscillator and the PLL will be gated off when entering the power-down mode (by setting a register on DSP0).

5.2.12 CODEC

The CODEC is composed of four plus one A/D mono converters and three D/A stereo converters.

Two channels of the ADC can operate both in audio mode and in FM mode. When in audio mode, it converts the audio bandwidth from 20Hz to 20KHz. The A to D is a third order Sigma-Delta converter with 20-bit resolution. When in FM mode, the converted bandwidth is up to 192KHz.

Additionally a lower resolution A to D converter is implemented. It is used to convert the level signal of the tuner. Alternatively it may be used to convert voice signals.

The DAC is a second order multi bits Sigma-Delta converter accepting 24 bits input data. All the reference voltages are generated inside the chip but they have to be decoupled with external capacitors.

5.2.13 Radio data system (RDS)

The RDS block is a hardware cell able to deliver the RDS frames through a dedicated serial interface. An RDS quality signal is also available. This block needs to be initialized at reset by the DSP, after that it works in background and does not need any further DSP support. RDS is made of 57kHz filter, demodulator, decoder with error correction and an I²C/SPI programmable interface with data buffer and interrupt output.

Due to its own interface, it may be considered as an independent function. Thus the module has a separate RDS I²C device address as well as a separate chip select line for the RDS SPI. Only the pins are shared with the DSP interfaces.

5.2.14 Clock scheme

Due to the programmable PLL oscillator, the clock scheme is very flexible. The customer may choose the clock frequency according to the application needs. However one should take into account several constraints:

- The RDS module needs a crystal frequency of 8.55 MHz or alternative an external 74.1MHz Oscillator. However the PLL may be supplied by an external clock reference and the crystal in parallel may drive the RDS module.
- The CODEC (A/D and D/A) module needs a clock of 512 times the audio sample rate (Fs).
- The audio sample rate (Fs) should be close to 44.1 kHz. This allows CD quality. Higher sample rates will reduce the number of DSP clock cycles per Fs and hence will reduce the available MIPS.
- The DSP core clock frequency may not exceed 76 MHz
- In a car radio system the second and third system clock harmonics (DSP clock and CODEC clock) should be outside the radio frequency bands.

Two examples of convenient clock schemes are shown in the following table:

Table 28. Examples of convenient clock schemes

	Clock scheme	Alternative⁽¹⁾
Fxtal	8.55 MHz	74.1 MHz
Fcomp	Fxtal / 4 2.14 MHz	Fxtal/21 3.53 MHz
Fvco	Fcomp * 106 226.58 MHz	Fcomp * 64 225.8 MHz
Fdsp	Fvco / 3 75.53 MHz	Fvco / 3 75.28 MHz
Fcodec	Fvco / 10 22.66 MHz	Fvco / 10 22.58 MHz
Fs	44.25 kHz	44.11 kHz

1. External clock oscillator used

6 Software features

A great flexibility is guaranteed by the two programmable DSP cores. A list of the main software functions, which can be implemented in the TDA7505, is enclosed hereafter:

6.1 AM/FM base band signal processing

- FM weak signal processing
- Integrated 19 kHz Pilot tone filter
- De-emphasis
- Stereo blend
- Variable high cut
- Flexible noise cancellation
- Flexible multipath detector
- Asynchronous demodulation allows the usage of any sample rate

6.2 Generic audio signal processing

- Loudness
- Bass, treble, fader control
- Volume control
- Distortion Limiting
- Premium Equalization
- Soft mute

6.3 TAPE signal processing

- Dolby B Noise Reduction
- Automatic Music Search

6.4 CD signal processing

- Dynamic Range Compression

6.5 Audiophile

- Parametric Equalization
- Crossover
- Channel Delays
- Center Channel Imaging Output
- Audio Noise Reduction

6.6 Audio decompression

- MP3 including C3 block decoder

6.7 Other

- Voice compression/decompression for traffic information storage
- Echo and noise canceling for mobile phone connection

6.8 Functional modes

The SW defines the whole functionality of the device, except RDS. Although ST is able to provide a complete set of SW, the customer may implement his own SW or may use third party SW. This allows a flexible adaptation to the application needs.

The concept allows the parallel processing of two independent audio sources. For example one source may go through the loudspeakers, whereas another source may feed a headphone. Additionally other sources like a phone or a navigation system may be mixed to the audio source. In case the 150 MIPS available are not sufficient, a co-dsp (e.g.: TDA7502) may be connected through the serial audio interface (SAI). Finally the device may be embedded into an audio bus system (e.g.: MOST).

Following table shows an example of possible modes:

Table 29. Example of possible modes

Source	Comment	AM/FM mode	CD mode (digital)	CD Changer mode (analog)	Tape mode (digital)	Traffic info play mode
AM/FM MPX (analog)	DSP1	Main source and RDS	Alternative Rear Source and RDS	Alternative Rear Source and RDS	Alternative Rear Source and RDS	Alternative Rear Source and RDS
CD changer (analog)	DSP1	Alternative Rear Source	Alternative Rear Source	Main source	Alternative Rear Source	Alternative Rear Source
Phone/Navi (analog)	DSP0	Summed to Main source	Summed to Main source	Summed to Main source	Summed to Main source	Summed to Main source
CD/CD ROM audio/MP3 (digital SPDIF)	DSP1	Alternative Rear Source through SRC	Main source through SRC	Alternative Rear Source through SRC	Alternative Rear Source through SRC	Alternative Rear Source through SRC
Tape via ADC (digital SAI)	Dolby B on DSP1	Alternative Rear Source	Alternative Rear Source	Alternative Rear Source	Main source	Alternative Rear Source
DSP co-processor	MDSP: master CO-dsp: slave	Available ⁽¹⁾	Available ⁽¹⁾	Available ⁽¹⁾	Available ⁽¹⁾	Available ⁽¹⁾
Traffic info storage	DSP0	Background recording	Background recording	Background recording	Background recording	Main source & Background recording
MOST bus	MDSP: slave Co-dsp: slave MOST: master	Available ⁽¹⁾	Available ⁽¹⁾	Available ⁽¹⁾	Available ⁽¹⁾	Available ⁽¹⁾

1. The total number of SAI channels is six. They must be split between MOST, Co-DSP and the external ADC for tape. In case of MOST, the DSP clock must be synchronized to the MOST bus.

Note: The main source (blue) may run in parallel with one of the alternative rear sources (yellow). Phone/Navi, DSP Co-processor, traffic info storage and MOST (green) are available in parallel to all modes.

7 Package information

In order to meet environmental requirements, ST offers these devices in ECOPACK® packages. These packages have a lead-free second level interconnect. The category of second Level Interconnect is marked on the package and on the inner box label, in compliance with JEDEC Standard JESD97. The maximum ratings related to soldering conditions are also marked on the inner box label. ECOPACK is an ST trademark. ECOPACK specifications are available at: www.st.com.

Figure 14. LQFP100 (14x14x1.4mm) mechanical data and package dimensions

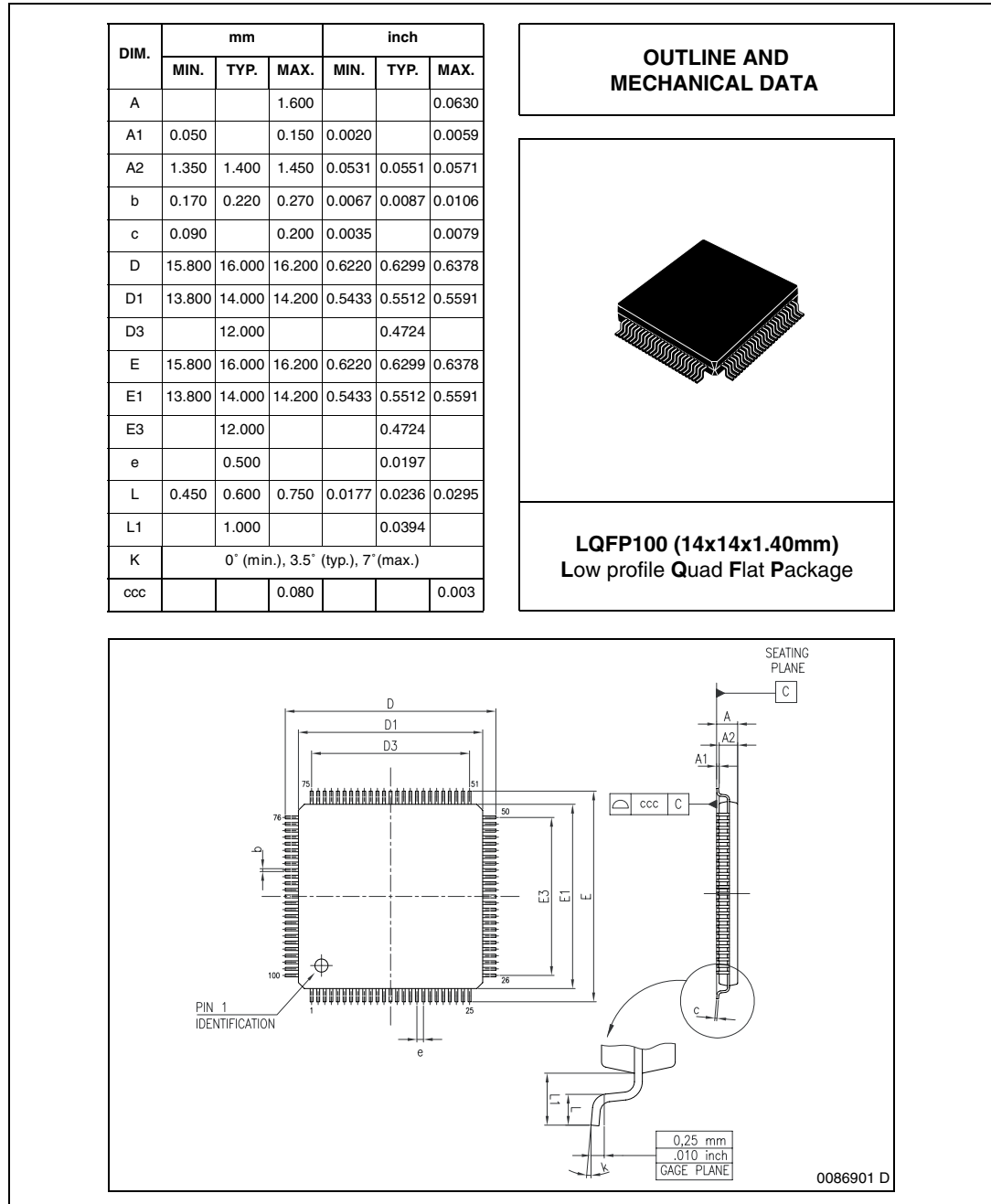

8 Revision history

Table 30. Document revision history

Date	Revision	Changes
23-Oct-2007	1	Initial release.

Please Read Carefully:

Information in this document is provided solely in connection with ST products. STMicroelectronics NV and its subsidiaries ("ST") reserve the right to make changes, corrections, modifications or improvements, to this document, and the products and services described herein at any time, without notice.

All ST products are sold pursuant to ST's terms and conditions of sale.

Purchasers are solely responsible for the choice, selection and use of the ST products and services described herein, and ST assumes no liability whatsoever relating to the choice, selection or use of the ST products and services described herein.

No license, express or implied, by estoppel or otherwise, to any intellectual property rights is granted under this document. If any part of this document refers to any third party products or services it shall not be deemed a license grant by ST for the use of such third party products or services, or any intellectual property contained therein or considered as a warranty covering the use in any manner whatsoever of such third party products or services or any intellectual property contained therein.

UNLESS OTHERWISE SET FORTH IN ST'S TERMS AND CONDITIONS OF SALE ST DISCLAIMS ANY EXPRESS OR IMPLIED WARRANTY WITH RESPECT TO THE USE AND/OR SALE OF ST PRODUCTS INCLUDING WITHOUT LIMITATION IMPLIED WARRANTIES OF MERCHANTABILITY, FITNESS FOR A PARTICULAR PURPOSE (AND THEIR EQUIVALENTS UNDER THE LAWS OF ANY JURISDICTION), OR INFRINGEMENT OF ANY PATENT, COPYRIGHT OR OTHER INTELLECTUAL PROPERTY RIGHT.

UNLESS EXPRESSLY APPROVED IN WRITING BY AN AUTHORIZED ST REPRESENTATIVE, ST PRODUCTS ARE NOT RECOMMENDED, AUTHORIZED OR WARRANTED FOR USE IN MILITARY, AIR CRAFT, SPACE, LIFE SAVING, OR LIFE SUSTAINING APPLICATIONS, NOR IN PRODUCTS OR SYSTEMS WHERE FAILURE OR MALFUNCTION MAY RESULT IN PERSONAL INJURY, DEATH, OR SEVERE PROPERTY OR ENVIRONMENTAL DAMAGE. ST PRODUCTS WHICH ARE NOT SPECIFIED AS "AUTOMOTIVE GRADE" MAY ONLY BE USED IN AUTOMOTIVE APPLICATIONS AT USER'S OWN RISK.

Resale of ST products with provisions different from the statements and/or technical features set forth in this document shall immediately void any warranty granted by ST for the ST product or service described herein and shall not create or extend in any manner whatsoever, any liability of ST.

ST and the ST logo are trademarks or registered trademarks of ST in various countries.

Information in this document supersedes and replaces all information previously supplied.

The ST logo is a registered trademark of STMicroelectronics. All other names are the property of their respective owners.

© 2007 STMicroelectronics - All rights reserved

STMicroelectronics group of companies

Australia - Belgium - Brazil - Canada - China - Czech Republic - Finland - France - Germany - Hong Kong - India - Israel - Italy - Japan - Malaysia - Malta - Morocco - Singapore - Spain - Sweden - Switzerland - United Kingdom - United States of America

www.st.com