

Features

- MECHANICALLY AND SPECTRALLY MATCHED TO THE PHOTOTRANSISTOR.
- WATER CLEAR LENS.
- PACKAGE : 1500PCS / REEL.
- MOIS TURE SENSITIVITY LEVEL : LEVEL 4.
- RoHS COMPLIANT.

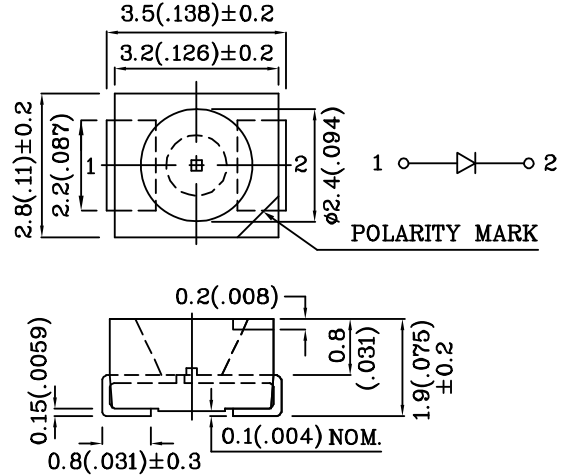

Notes:

1. All dimensions are in millimeters (inches).
2. Tolerance is ± 0.25(0.01") unless otherwise noted.
3. Specifications are subject to change without notice.

Absolute Maximum Ratings (TA=25°C)		TNI (GaAs)	Unit
Reverse Voltage	VR	5	V
Forward Current	IF	50	mA
Forward Current (Peak) 1/100 Duty Cycle 10us Pulse Width	iFS	1.2	A
Power Dissipation	PT	80	mW
Operating Temperature	TA	-40 ~ +85	°C
Storage Temperature	Tstg	-40 ~ +85	

Operating Characteristics (TA=25°C)		TNI (GaAs)	Unit
Forward Voltage (Typ.) (IF=20mA)	VF	1.2	V
Forward Voltage (Max.) (IF=20mA)	VF	1.6	V
Reverse Current (Max.) (VR=5V)	IR	10	uA
Wavelength Of Peak Emission (Typ.) (IF=20mA)	λ P	940	nm
Spectral Line Full Width At Half-Maximum (Typ.) (IF=20mA)	Δλ	50	nm
Capacitance (Typ.) (VF=0V, f=1MHz)	C	90	pF

Part Number	Emitting Material	Lens-color	Luminous Intensity Po (Mw/sr) @20mA*50mA		Wavelength nm λ P	Viewing Angle 2 θ 1/2
			min.	typ.		
ZTNI45W	GaAs	Water Clear	1.6	2.8	940	120°
			*2.6	*7		

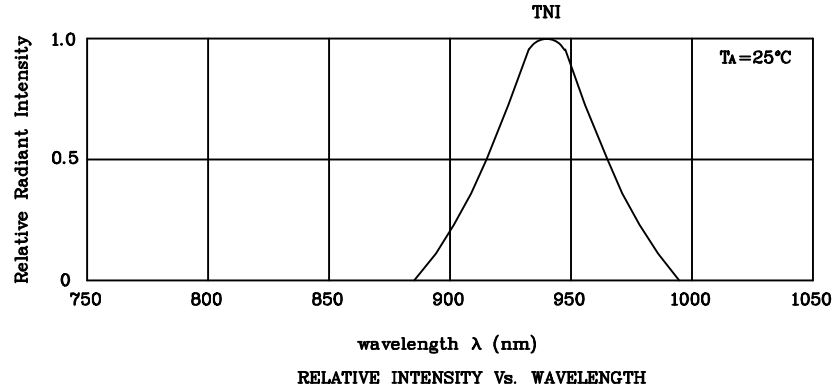

❖ TNI

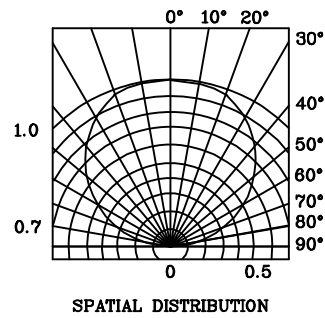
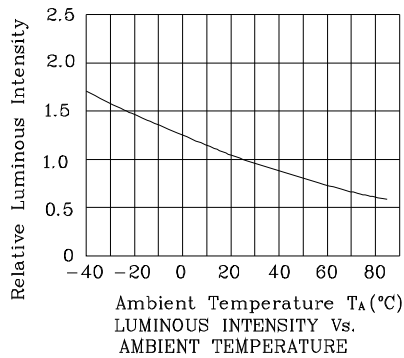
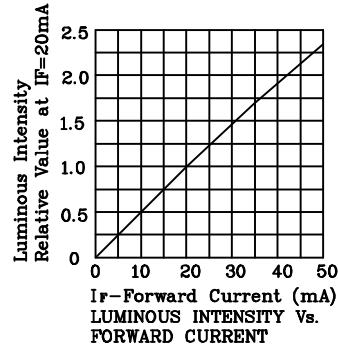
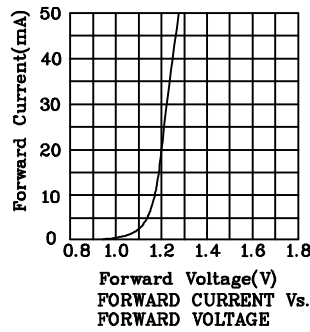

Reflow Soldering Profile For Lead-free SMT Process.

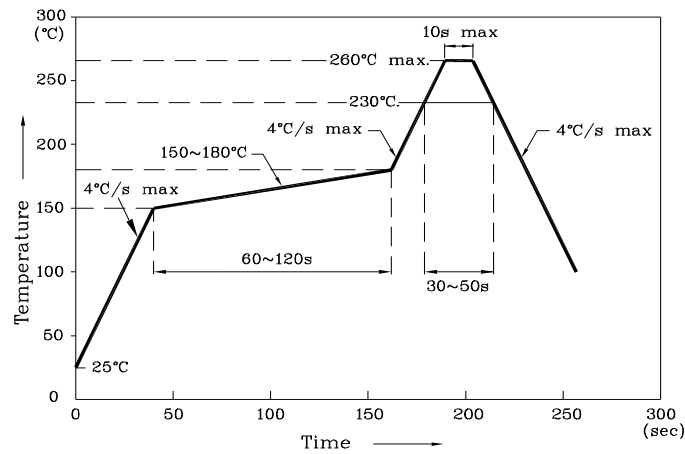

Notes:

1. Maximum soldering temperature should not exceed 260°C.
2. Recommended reflow temperature: 145°C-260°C.
3. Do not put stress to the epoxy resin during high temperatures conditions.

❖ Recommended Soldering Pattern
(Units : mm;Tolerance:±0.1)

❖ The device has a single mounting surface. The device must be mounted according to the specifications.

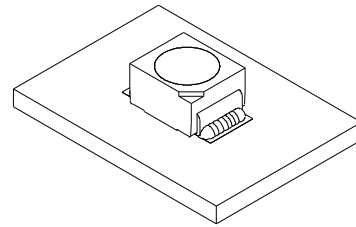
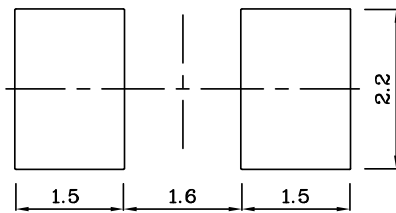

❖ Tape Specification (Units : mm)

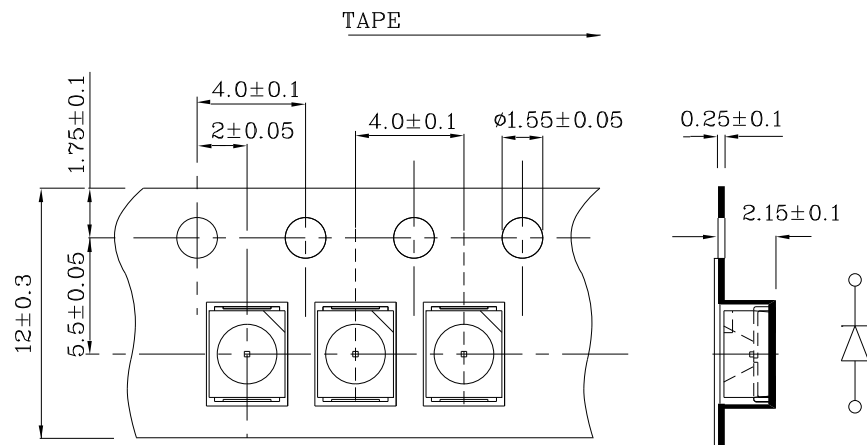

Remarks:



If special sorting is required (e.g. binning based on forward voltage or radiant intensity/ luminous flux), the typical accuracy of the sorting process is as follows:

1. Radiant Intensity/ luminous flux: +/-15%
2. Forward Voltage: +/-0.1V

Note: Accuracy may depend on the sorting parameters.

PACKING & LABEL SPECIFICATIONS

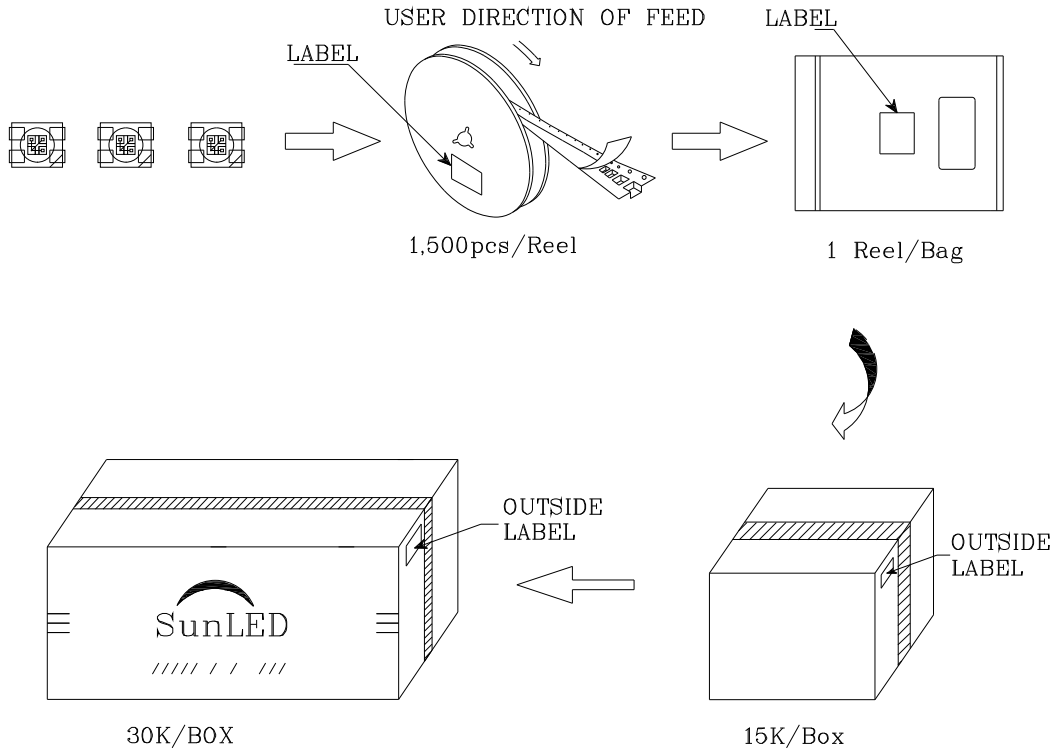
ZTNI45W

Q.C.
Q C
XX XX. XXXX
PASSED

P/NO : Zxxx45x	
QTY : 1,500 pcs	CODE: XXX
S/N : XX	
LOT NO :	
 XXXXXXXXXXXXXXXXXXXXXXXXXXXX	
RoHS Compliant	