



STM1403

3 V FIPS-140 security supervisor with battery switchover

Features

- STM1403 supports FIPS-140 security level 3+
 - Four high-impedance physical tamper inputs
 - Over/under operating voltage detector
 - Security alarm ($\overline{\text{SAL}}$) on tamper detection
- Supervisory functions
 - Automatic battery switchover
 - $\overline{\text{RST}}$ output (open drain)
 - Manual (push-button) reset input ($\overline{\text{MR}}$)
 - Power-fail comparator ($\overline{\text{PFI}}/\overline{\text{PFO}}$)
- $\overline{\text{Vccsw}}$ (V_{CC} switch output)
 - Low when switched to V_{CC}
 - High when switched to V_{BAT} (BATT ON indicator)
- Battery low voltage detector (power-up)
- Optional V_{REF} (1.237 V)
 - (Available for STM1403A only)
- Low battery supply current (2.8 μA , typ)
- Secure low profile 16-pin, 3 x 3 mm, QFN package

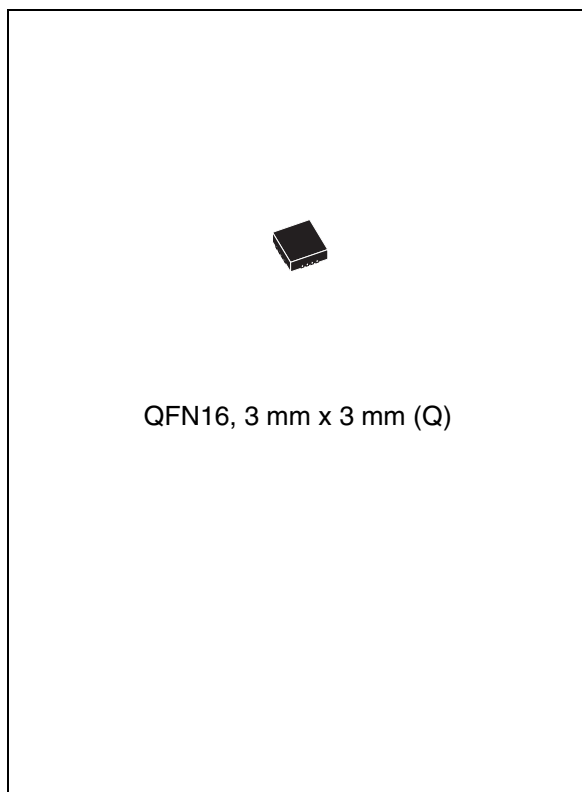

Table 1. Device summary

| Device | Standard supervisory functions ⁽¹⁾ | Physical tamper inputs | Over/under voltage alarms | V_{REF} (1.237 V) option | V_{OUT} status, during alarm | $\overline{\text{Vccsw}}$ status, during alarm |
|-------------------------|---|------------------------|---------------------------|-----------------------------------|---------------------------------------|--|
| STM1403A | ✓ | ✓ | ✓ | ✓ | ON | Normal mode ⁽²⁾ |
| STM1403B ⁽³⁾ | ✓ | ✓ | ✓ | Note ⁽⁴⁾ | High-Z | High |
| STM1403C | ✓ | ✓ | ✓ | Note ⁽⁴⁾ | Ground | High |

1. Reset output, power-fail comparator, battery low detection ($\overline{\text{SAL}}$, $\overline{\text{RST}}$, $\overline{\text{PFO}}$, and $\overline{\text{BLD}}$ are open drain).

2. Normal mode: low when V_{OUT} is internally switched to V_{CC} and high when V_{OUT} is internally switched to battery.

3. Contact local ST sales office for availability.

4. Pin 9 is the V_{REF} pin for STM1403A. It is the V_{TPU} pin for STM1403B/C.

Contents

| | | |
|----------|---|-----------|
| 1 | Description | 6 |
| 1.1 | V_{OUT} pin modes | 6 |
| 1.1.1 | STM1403A | 6 |
| 1.1.2 | STM1403B | 6 |
| 1.1.3 | STM1403C | 6 |
| 2 | Pin descriptions | 11 |
| 2.1 | \overline{SAL} , security alarm output (open drain) | 11 |
| 2.1.1 | TP_1, TP_3 | 11 |
| 2.1.2 | TP_2, TP_4 | 11 |
| 2.1.3 | $\overline{V_{CCSW}}$, V_{CC} switch output | 11 |
| 2.1.4 | \overline{BLD} , V_{BAT} low voltage detect output (open drain) | 12 |
| 2.1.5 | Active-low \overline{RST} output (open drain) | 12 |
| 2.1.6 | \overline{MR} , manual reset input | 12 |
| 2.1.7 | \overline{PFO} , power-fail output (open drain) | 12 |
| 2.1.8 | PFI, power-fail input | 12 |
| 2.1.9 | V_{REF} reference voltage output (1.237, typ) | 12 |
| 2.1.10 | V_{OUT} | 13 |
| 2.1.11 | V_{TPU} | 13 |
| 2.1.12 | V_{CC} | 13 |
| 2.1.13 | V_{BAT} | 13 |
| 2.1.14 | V_{SS} | 13 |
| 3 | Operation | 14 |
| 3.1 | Reset input | 14 |
| 3.2 | Push-button reset input | 14 |
| 3.3 | Backup battery switchover | 14 |
| 3.4 | Power-fail input/output | 15 |
| 3.5 | Applications information | 15 |
| 3.6 | Negative-going V_{CC} transients and undershoot | 16 |
| 4 | Tamper detection | 17 |
| 4.1 | Physical | 17 |

| | | |
|-----------|--|-----------|
| 4.2 | Supply voltage | 17 |
| 5 | Typical operating characteristics | 18 |
| 6 | Maximum ratings | 23 |
| 7 | DC and AC parameters | 24 |
| 8 | Package mechanical data | 30 |
| 9 | Part numbering | 32 |
| 10 | Revision history | 34 |

List of tables

| | | |
|-----------|--|----|
| Table 1. | Device summary | 1 |
| Table 2. | Signal names | 7 |
| Table 3. | I/O status in battery backup | 15 |
| Table 4. | Absolute maximum ratings | 23 |
| Table 5. | Operating and AC measurement condition. | 24 |
| Table 6. | DC and AC characteristics | 25 |
| Table 7. | Physical and environmental tamper detection levels | 29 |
| Table 8. | QFN16 – 16-lead, quad, flat package, no lead, 3 x 3 mm body size, mechanical data . . . | 31 |
| Table 9. | Ordering information scheme (see Figure 30 on page 33 for marking information) | 32 |
| Table 10. | Document revision history | 34 |

List of figures

| | | |
|------------|---|----|
| Figure 1. | Logic diagram | 7 |
| Figure 2. | QFN16 connections | 8 |
| Figure 3. | Block diagram | 8 |
| Figure 4. | Hardware hookup | 9 |
| Figure 5. | Tamper pin (TP ₁ or TP ₃) normally high (NH) external hookup (switch closed) | 9 |
| Figure 6. | Tamper pin (TP ₁ or TP ₃) normally high (NH) external hookup (switch open) | 10 |
| Figure 7. | Tamper pin (TP ₂ or TP ₄) normally low (NL) external hookup (switch closed) | 10 |
| Figure 8. | Tamper pin (TP ₂ or TP ₄) normally low (NL) external hookup (switch open) | 10 |
| Figure 9. | Power-fail comparator waveform | 16 |
| Figure 10. | Supply voltage protection | 16 |
| Figure 11. | V _{BAT} -to-V _{OUT} on-resistance vs. temperature | 18 |
| Figure 12. | Supply current vs. temperature (no load) | 18 |
| Figure 13. | V _{PFI} threshold vs. temperature | 19 |
| Figure 14. | Reset comparator propagation delay vs. temperature | 19 |
| Figure 15. | Power-up t _{rec} vs. temperature | 19 |
| Figure 16. | Normalized reset threshold vs. temperature | 20 |
| Figure 17. | PFI to $\overline{\text{PFO}}$ propagation delay vs. temperature | 20 |
| Figure 18. | $\overline{\text{RST}}$ output voltage vs. supply voltage | 20 |
| Figure 19. | $\overline{\text{RST}}$ response time (assertion) | 21 |
| Figure 20. | Power-fail comparator response time (assertion) | 21 |
| Figure 21. | Power-fail comparator response time (de-assertion) | 21 |
| Figure 22. | V _{CC} to reset propagation delay vs. temperature | 22 |
| Figure 23. | Maximum transient duration vs. reset threshold overdrive | 22 |
| Figure 24. | AC testing input/output waveforms | 24 |
| Figure 25. | $\overline{\text{MR}}$ timing waveform | 24 |
| Figure 26. | STM1403 switchover diagram, condition A (V _{BAT} < V _{SW}) | 24 |
| Figure 27. | STM1403 switchover diagram, condition B (V _{BAT} > V _{SW}) | 25 |
| Figure 28. | QFN16 – 16-lead, quad, flat package, no lead, 3 x 3 mm body size, outline | 30 |
| Figure 29. | QFN16 – 16-lead, quad, flat package, no lead, 3 x 3 mm, recommended footprint | 31 |
| Figure 30. | Topside marking information | 33 |

1 Description

The STM1403 family of security supervisors are a low power family of intrusion (tamper) detection chips targeted at manufacturers of POS terminals and other systems, to enable them to meet **physical and/or environmental** intrusion monitoring requirements as mandated by various standards, such as Federal Information Processing Standards (FIPS) Pub 140 entitled “Security Requirements for Cryptographic Modules,” published by the National Institute of Standards and Technology, U.S. Department of Commerce), EMVCo, ISO, ZKA, and VISA PED. STM1403 supports target levels 3 and lower.

The STM1403 includes automatic battery switchover, $\overline{\text{RST}}$ output (open drain), manual (push-button) reset input ($\overline{\text{MR}}$), power-fail comparator (PFI/ $\overline{\text{PFO}}$), physical and/or environmental tamper detect/security alarm, and battery low voltage detect features.

The STM1403A also offers a V_{REF} (1.237 V) as an option on pin 9. On the STM1403B/C, this pin is V_{TPU} (internally switched V_{CC} or V_{BAT}).

1.1 V_{OUT} pin modes

The STM1403 is available in three versions, corresponding to three modes of the V_{OUT} pin (supply voltage out), when the $\overline{\text{SAL}}$ (security alarm) is asserted (active-low) upon tamper detection:

1.1.1 STM1403A

V_{OUT} stays ON (at V_{CC} or V_{BAT}) when $\overline{\text{SAL}}$ is driven low (activated).

1.1.2 STM1403B

V_{OUT} is set to High-Z when $\overline{\text{SAL}}$ is driven low (activated).

1.1.3 STM1403C

V_{OUT} is driven to ground when $\overline{\text{SAL}}$ is activated (may be used when V_{OUT} is connected directly to the V_{CC} pin of the external SRAM that holds the cryptographic codes).

All variants (see [Table 1: Device summary](#)) are pin-compatible and available in a security-friendly, low profile, 16-pin QFN package.

Figure 1. Logic diagram

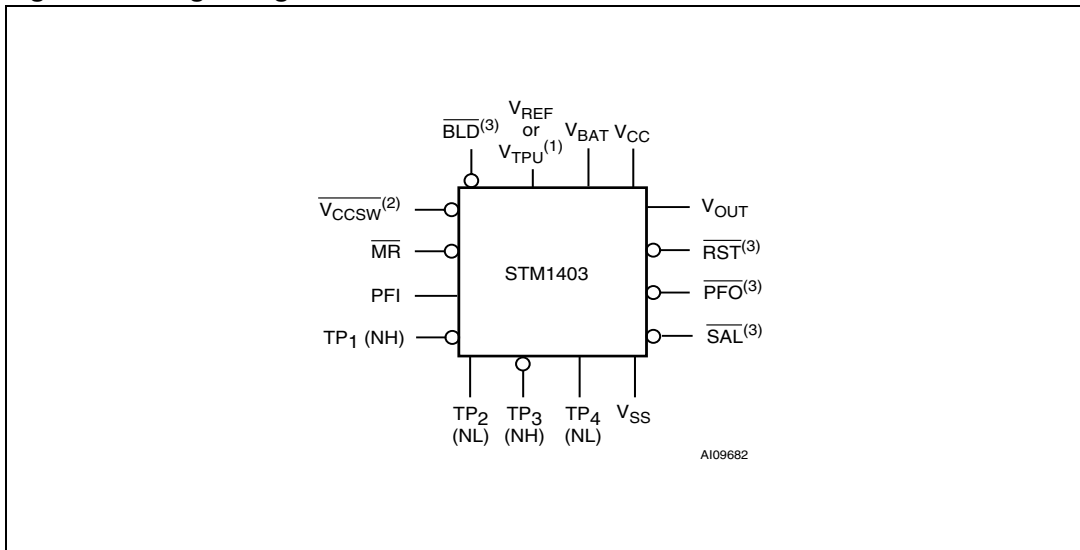

1. V_{REF} only for STM1403A; V_{TPU} for STM1403B/C.
2. Normal mode: low when V_{OUT} is internally switched to V_{CC} and high when V_{OUT} is internally switched to battery.
3. \overline{SAL} , \overline{RST} , \overline{PFO} , and \overline{BLD} are open drain.

Table 2. Signal names

| | |
|-----------------------------|---|
| $\overline{V_{CCSW}}^{(1)}$ | V_{CC} switch output |
| \overline{MR} | Manual (push-button) reset input |
| PFI | Power-fail Input |
| $TP_1 - TP_4$ | Independent physical tamper detect pins 1 through 4 |
| V_{OUT} | Supply voltage output |
| $\overline{RST}^{(2)}$ | Active-low reset output |
| $\overline{PFO}^{(2)}$ | Power-fail output |
| $\overline{SAL}^{(2)}$ | Security alarm output |
| $\overline{BLD}^{(2)}$ | Battery low voltage detect |
| $V_{REF}^{(3)}$ | 1.237 V reference voltage |
| $V_{TPU}^{(3)}$ | Tamper pull-up (V_{CC} or V_{BAT}) |
| V_{BAT} | Backup supply voltage |
| V_{CC} | Supply voltage |
| V_{SS} | Ground |

1. Normal mode: low when V_{OUT} is internally switched to V_{CC} and high when V_{OUT} is internally switched to battery.
2. \overline{SAL} , \overline{RST} , \overline{PFO} , and \overline{BLD} are open drain.
3. V_{REF} only for STM1403A; V_{TPU} for STM1403B/C.

Note: See [Section 2: Pin descriptions on page 11](#) for details.

Figure 2. QFN16 connections

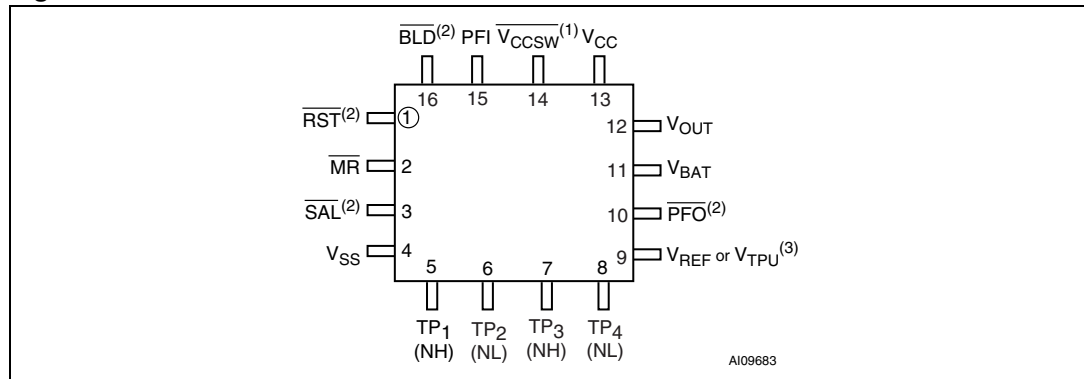

Note:

See Section 2: Pin descriptions on page 11 for details.

1. Normal mode: low when V_{OUT} is internally switched to V_{CC} and high when V_{OUT} is internally switched to battery.
2. \overline{SAL} , \overline{RST} , \overline{PFO} , and \overline{BLD} are open drain.
3. V_{REF} only for STM1403A; V_{TPU} for STM1403B/C

Figure 3. Block diagram

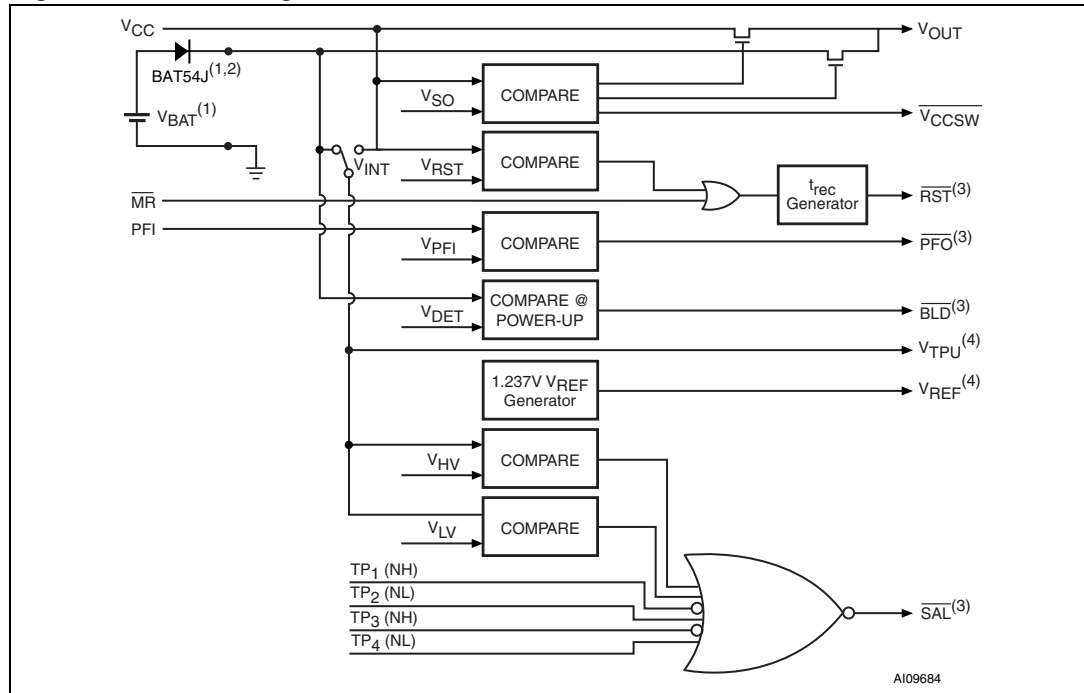

1. BAT54J (from STMicroelectronics) recommended
2. Required for battery-reverse charging protection
3. Open drain
4. V_{REF} only for STM1403; V_{TPU} for STM1403B/C

Figure 4. Hardware hookup

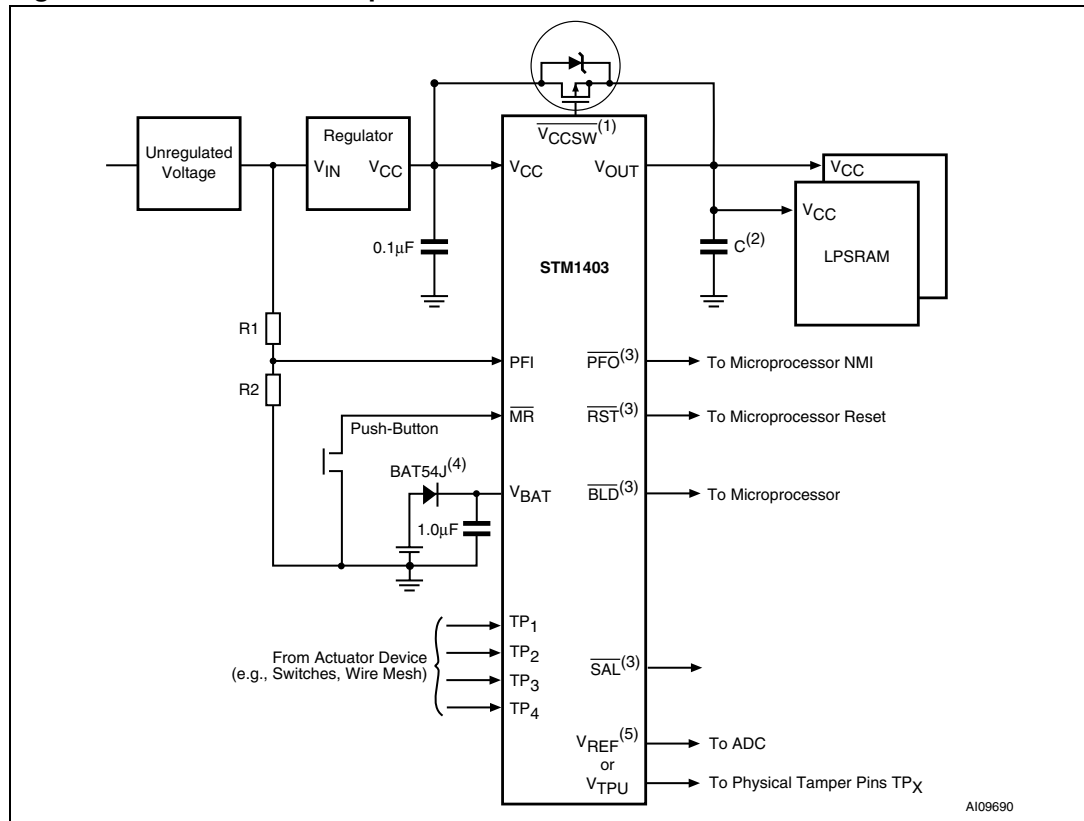

1. Normal mode: low when V_{OUT} is internally switched to V_{CC} and high when V_{OUT} is internally switched to battery.
2. Capacitor (C) is typically $\geq 10 \mu\text{F}$.
3. Open drain
4. Diode is required for battery reverse charge protection.
5. V_{REF} only for STM1403; V_{TPU} for STM1403B/C.

Figure 5. Tamper pin (TP_1 or TP_3) normally high (NH) external hookup (switch closed)

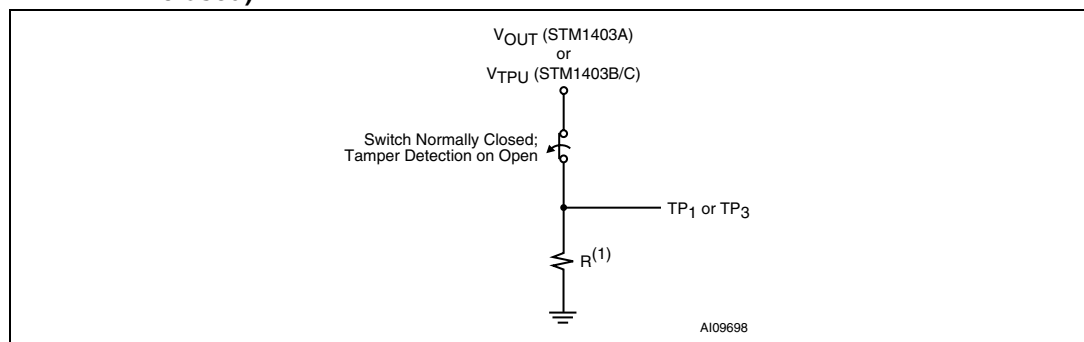

1. R typical is 10 MΩ. Resistors must be protected against conductive materials.

Figure 6. Tamper pin (TP₁ or TP₃) normally high (NH) external hookup (switch open)

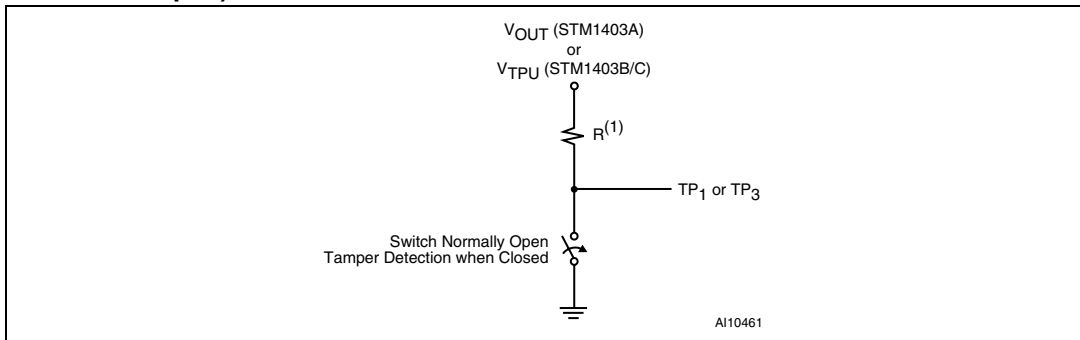

1. R typical is 10MΩ. Resistors must be protected against conductive materials.

Figure 7. Tamper pin (TP₂ or TP₄) normally low (NL) external hookup (switch closed)

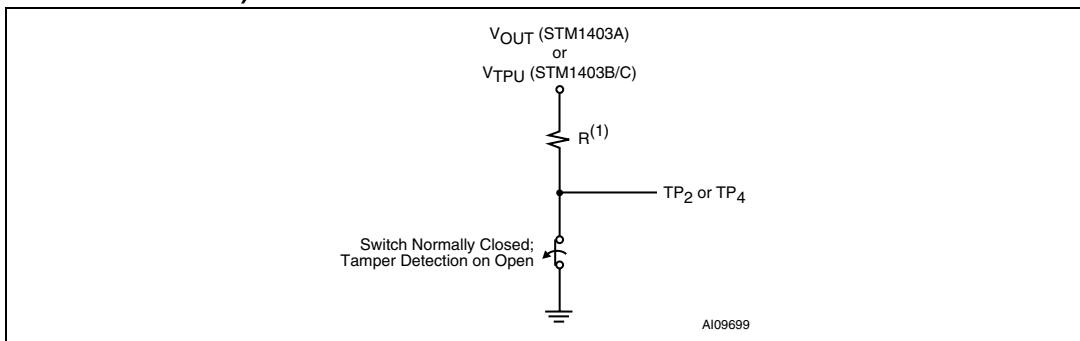

1. R typical is 10 MΩ. Resistors must be protected against conductive materials.

Figure 8. Tamper pin (TP₂ or TP₄) normally low (NL) external hookup (switch open)

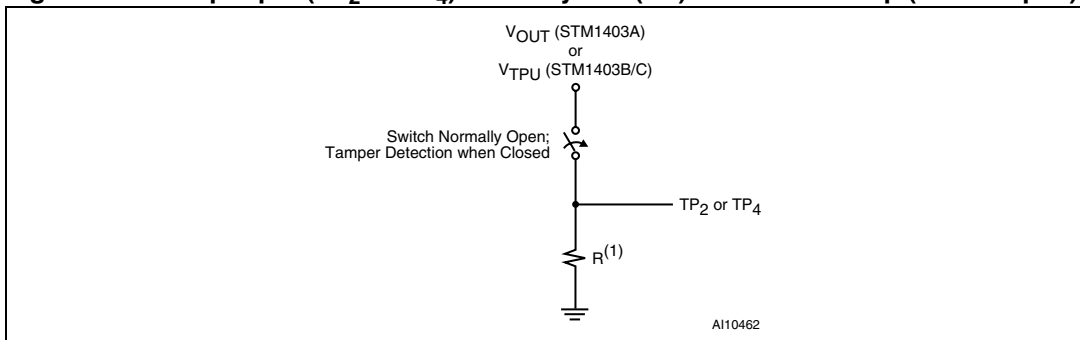

1. R typical is 10 MΩ. Resistors must be protected against conductive materials.

2 Pin descriptions

See [Figure 1: Logic diagram](#) and [Table 2: Signal names](#) for a brief overview of the signals connected to this device.

2.1 $\overline{\text{SAL}}$, security alarm output (open drain)

This signal can be generated when ANY of the following conditions occur:

- $V_{\text{INT}} > V_{\text{HV}}$, where V_{HV} = upper voltage trip limit (4.2 V typ); and where $V_{\text{INT}} = V_{\text{CC}}$ or V_{BAT} ;
- $V_{\text{INT}} < V_{\text{LV}}$, where V_{LV} = lower voltage trip limit (2.0 V typ); and where $V_{\text{INT}} = V_{\text{CC}}$ or V_{BAT} ; or
- When any of the physical tamper inputs, TP_1 to TP_4 , change from their normal states to the opposite (i.e., intrusion of a physical enclosure).

- Note:*
- 1 The default state of the $\overline{\text{SAL}}$ output during initial power-up is undetermined.
 - 2 The alarm function will operate either with V_{CC} on or when the part is internally switched from V_{CC} to V_{BAT} .

2.1.1 TP_1, TP_3

Physical tamper detect pin set normally to high (NH). They are connected externally through a closed switch or a high-impedance resistor to V_{OUT} (in the case of STM1403A) or V_{TPU} (in the case of STM1403B/C). A tamper condition will be detected when the input pin is pulled low (see [Figure 5](#) and [Figure 6](#)). If not used, tie the pin to V_{OUT} (for STM1403A) or V_{TPU} (for STM1403B/C).

2.1.2 TP_2, TP_4

Physical tamper detect pin set normally to low (NL). They are connected externally through a high-impedance resistor or a closed switch to V_{SS} . A tamper condition will be detected when the input pin is pulled high (see [Figure 7](#) and [Figure 8](#)). If not used, tie the pin to V_{SS} .

2.1.3 $\overline{\text{Vccsw}}, V_{\text{CC}}$ switch output

This output is low when V_{OUT} (see [Section 2.1.10: \$V_{\text{OUT}}\$ on page 13](#)) is internally switched to V_{CC} ; in this mode it may be used to turn on an external p-channel MOSFET switch which can source an external device directly from V_{CC} for currents greater than 80 mA (bypassing the STM1403).

This pin goes high when V_{OUT} is internally switched to V_{BAT} and may be used as a “BATT ON” indicator.

If a security alarm ($\overline{\text{SAL}}$) is issued on tamper, then the state of the $\overline{\text{Vccsw}}$ pin is as follows:

1. STM1403A (V_{OUT} remains ON when \overline{SAL} is active-low): $\overline{V_{CCSW}}$ pin will continue to operate in normal mode;
2. STM1403B (V_{OUT} is taken to High-Z when \overline{SAL} is active-low): $\overline{V_{CCSW}}$ pin will be set to high when this occurs; and
3. STM1403C (V_{OUT} is driven to ground when \overline{SAL} is active-low): $\overline{V_{CCSW}}$ pin will be set to high when this occurs.

2.1.4 \overline{BLD} , V_{BAT} low voltage detect output (open drain)

This is an internally loaded test of the battery, activated only during a power-up sequence to insure that the battery is good either prior to or after encapsulation of the module. There are three customer options for V_{DET} :

- 2.3 V (2.5 V – external diode drop of about 0.2 V) for a 3 V lithium cell
- 2.5 V (2.7 V – 0.2 V) for a 3 V lithium cell or
- 3.2 V (3.4 V – 0.2 V) for a 3.68 V lithium “AA” battery

This output pin will go active-low when it detects a voltage on the V_{BAT} pin below V_{DET} . \overline{BLD} will be released when V_{CC} drops below V_{RST} .

2.1.5 Active-low \overline{RST} output (open drain)

Goes low and stays low when V_{CC} drops below V_{RST} (reset threshold selected by the customer), or when \overline{MR} is logic low. It remains low for t_{rec} (200ms, typical) AFTER V_{CC} rises above V_{RST} and \overline{MR} goes from low to high.

2.1.6 \overline{MR} , manual reset input

A logic low on \overline{MR} asserts the \overline{RST} output. The \overline{RST} output remains asserted as long as \overline{MR} is low and for t_{rec} after \overline{MR} returns to high. This active low input has an internal 40 k Ω (typical) pull-up resistor. It can be driven from a TTL or CMOS logic line or shorted to ground with a switch. Leave it open if unused.

2.1.7 \overline{PFO} , power-fail output (open drain)

When PFI is less than V_{PFI} (power-fail input threshold voltage) or V_{CC} falls below V_{SW} (battery switchover threshold ~ 2.4 V), \overline{PFO} goes low, otherwise, \overline{PFO} remains high. Leave this pin open if unused.

2.1.8 PFI, power-fail input

When PFI is less than V_{PFI} , or when V_{CC} falls below V_{SW} (see \overline{PFO} , above), \overline{PFO} goes active-low. If this function is unused, connect this pin to V_{SS} .

2.1.9 V_{REF} reference voltage output (1.237, typ)

This is valid only when V_{CC} is between 2.4 V and 3.6 V. When V_{CC} falls below 2.4 V (V_{SW}), V_{REF} is pulled to ground with an internal 100 k Ω resistor. This is an optional feature available on the STM1403A. On the STM1403B/C, this pin is V_{TPU} (internally switched V_{CC} or V_{BAT}). If unused, this pin should float.

2.1.10 V_{OUT}

This is the supply voltage output. When V_{CC} rises above V_{SO} (battery backup switchover voltage), V_{OUT} is supplied from V_{CC} . In this condition, V_{OUT} may be connected externally to V_{CC} through a p-channel MOSFET switch. When V_{CC} falls below the lower value of V_{SW} (~2.4 V), or V_{BAT} , V_{OUT} is supplied from V_{BAT} . It is recommended that the V_{OUT} pin be connected externally to a capacitor that will retain a charge for a period of time, in case an intruder forces V_{CC} or V_{BAT} to ground. The rectifying diode connected from the positive terminal of the battery to the V_{BAT} pin of the STM1403 will prevent discharge of the capacitor.

Three variations of parts will be offered with the following options:

1. STM1403A: V_{OUT} remains ON when \overline{SAL} is active-low; $\overline{V_{CCSW}}$ pin will continue to operate in normal mode (see [Section 2.1.3: \$V_{CCSW}\$, \$V_{CC}\$ switch output on page 11](#));
2. STM1403B: V_{OUT} is taken to High-Z when \overline{SAL} is active-low; $\overline{V_{CCSW}}$ pin will be set to high when this occurs; and
3. STM1403C: V_{OUT} is driven to ground when \overline{SAL} is active-low; $\overline{V_{CCSW}}$ pin will be set to high when this occurs.

2.1.11 V_{TPU}

For STM1403B and STM1403C, this pin provides pull-up voltage for the physical tamper pins (TP1-4). This pin is not to be used as voltage supply source for any other purpose.

Note: V_{TPU} is the internally switched supply voltage from either the V_{CC} pin or the V_{BAT} pin.

2.1.12 V_{CC}

This is the supply voltage (2.2 V to 3.6 V).

2.1.13 V_{BAT}

This is the secondary (backup battery) supply voltage. The pin is connected to the positive terminal of the battery with a rectifying diode like the BAT54J from STMicroelectronics for reverse charge protection. Voltage at this pin, after diode rectification, will be approximately 0.2 V less than the battery voltage, and will depend on the type of battery used as well as the I_{BAT} being drawn. (A capacitor of at least 1.0 μ F connected between the V_{BAT} pin and V_{SS} is required.) If no battery is used, connect the V_{BAT} pin to the V_{CC} pin.

2.1.14 V_{SS}

Ground, V_{SS} , is the reference for the power supply. It must be connected to system ground.

3 Operation

3.1 Reset input

The STM1403 security supervisor asserts a reset signal to the MCU whenever V_{CC} goes below the reset threshold (V_{RST}), or when the push-button reset input (\overline{MR}) is taken low. \overline{RST} is guaranteed to be a logic low for $0V < V_{CC} < V_{RST}$ if V_{BAT} is greater than 1V. Without a backup battery, \overline{RST} is guaranteed valid down to $V_{CC} = 1V$.

During power-up, once V_{CC} exceeds the reset threshold an internal timer keeps \overline{RST} low for the reset time-out period, t_{rec} . After this interval \overline{RST} returns high.

If V_{CC} drops below the reset threshold, \overline{RST} goes low. Each time \overline{RST} is asserted, it stays low for at least the reset time-out period (t_{rec}). Any time V_{CC} goes below the reset threshold the internal timer clears. The reset timer starts when V_{CC} returns above the reset threshold.

3.2 Push-button reset input

A logic low on \overline{MR} asserts reset. Reset remains asserted while \overline{MR} is low, and for t_{rec} (see [Figure 25 on page 24](#)) after it returns high. The \overline{MR} input has an internal 40 k Ω pull-up resistor, allowing it to be left open if not used. This input can be driven with TTL/CMOS-logic levels or with open-drain/collector outputs. Connect a normally open momentary switch from \overline{MR} to ground to create a manual reset function; external debounce circuitry is not required. If \overline{MR} is driven from long cables or the device is used in a noisy environment, connect a 0.1 μF capacitor from \overline{MR} to V_{SS} to provide additional noise immunity. \overline{MR} may float, or be tied to V_{CC} when not used.

3.3 Backup battery switchover

In the event of a power failure, it may be necessary to preserve the contents of external SRAM through V_{OUT} . With a backup battery installed with voltage V_{BAT} , the devices automatically switch the SRAM to the backup supply when V_{CC} falls.

Note: If backup battery is not used, connect both V_{BAT} and V_{OUT} to V_{CC} .

This family of security supervisors does not always connect V_{BAT} to V_{OUT} when V_{BAT} is greater than V_{CC} . V_{BAT} connects to V_{OUT} (through a 100 Ω switch) when V_{CC} is below V_{SW} (~2.4 V) or V_{BAT} (whichever is lower). This is done to allow the backup battery (e.g., a 3.6 V battery) to have a higher voltage than V_{CC} .

Assuming that $V_{BAT} > 2.0$ V, switchover at V_{SO} ensures that battery backup mode is entered before V_{OUT} gets too close to the 2.0 V minimum required to reliably retain data in most external SRAMs. When V_{CC} recovers, hysteresis is used to avoid oscillation around the V_{SO} point. V_{OUT} is connected to V_{CC} through a 3 Ω PMOS power switch.

Note: The backup battery may be removed while V_{CC} is valid, assuming V_{BAT} is adequately decoupled (0.1 μF typ), without danger of triggering a reset.

Table 3. I/O status in battery backup

| Pin | Status |
|---------------------------|--|
| V _{OUT} | Connected to V _{BAT} through internal switch |
| V _{CC} | Disconnected from V _{OUT} |
| PFI | Disabled |
| $\overline{\text{PFO}}$ | Logic low |
| $\overline{\text{MR}}$ | Disabled |
| $\overline{\text{RST}}$ | Logic low |
| V _{BAT} | Connected to V _{OUT} |
| $\overline{\text{VCCSW}}$ | Logic high |
| V _{REF} | Pulled to V _{SS} below 2.4 V (V _{SW}) |
| BLD | Logic high |
| V _{TPU} | Connected to V _{BAT} through an internal switch |

3.4 Power-fail input/output

The power-fail input (PFI) is compared to an internal reference voltage (independent from the V_{RST} comparator). If PFI is less than the power-fail threshold (V_{PFI}), the power-fail output ($\overline{\text{PFO}}$) will go low. This function is intended for use as an undervoltage detector to signal a failing power supply. Typically PFI is connected through an external voltage divider (see [Figure 4 on page 9](#)) to either the unregulated DC input (if it is available) or the regulated output of the V_{CC} regulator. The voltage divider can be set up such that the voltage at PFI falls below V_{PFI} several milliseconds before the regulated V_{CC} input to the STM1403 or the microprocessor drops below the minimum operating voltage.

During battery backup, the power-fail comparator is turned off and $\overline{\text{PFO}}$ goes (or remains) low (see [Figure 9 on page 16](#)). This occurs after V_{CC} drops below V_{SW} (~2.4V). When power returns, the power-fail comparator is enabled and $\overline{\text{PFO}}$ follows PFI. If the comparator is unused, PFI should be connected to V_{SS} and $\overline{\text{PFO}}$ left unconnected. $\overline{\text{PFO}}$ may be connected to $\overline{\text{MR}}$ so that a low voltage on PFI will generate a reset output.

3.5 Applications information

These supervisor circuits are not short-circuit protected. Shorting V_{OUT} to ground - excluding power-up transients such as charging a decoupling capacitor - destroys the device. Decouple both V_{CC} and V_{BAT} pins to ground by placing 0.1 μF capacitors as close to the device as possible.

Figure 9. Power-fail comparator waveform

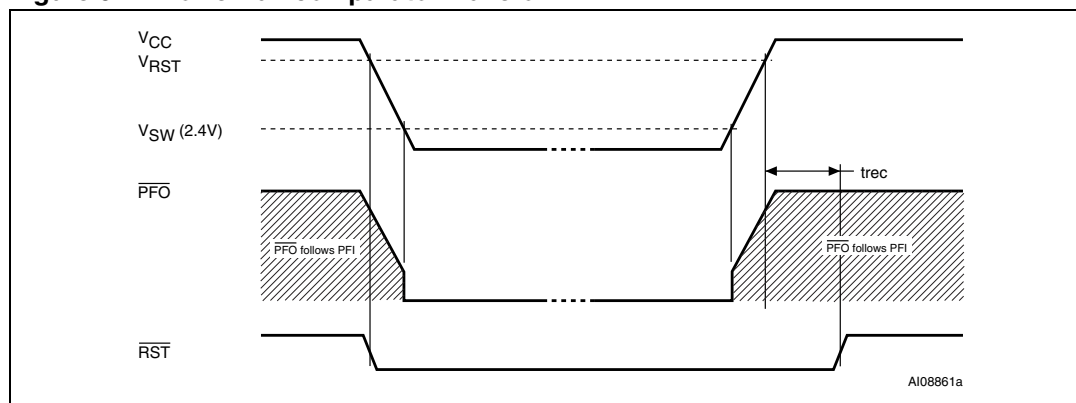

3.6 Negative-going V_{CC} transients and undershoot

The STM1403 devices are relatively immune to negative-going V_{CC} transients (glitches). [Figure 23 on page 22](#) was generated using a negative pulse applied to V_{CC} , starting at $V_{RST} + 0.3\text{ V}$ and ending below the reset threshold by the magnitude indicated (comparator overdrive). The graph indicates the maximum pulse width a negative V_{CC} transient can have without causing a reset pulse. As the magnitude of the transient increases (further below the threshold), the maximum allowable pulse width decreases. Any combination of duration and overdrive which lies under the curve will NOT generate a reset signal. Typically, a V_{CC} transient that goes 100 mV below the reset threshold and lasts 40 μs or less will not cause a reset pulse. A 0.1 μF bypass capacitor mounted as close as possible to the V_{CC} pin provides additional transient immunity (see [Figure 10](#)).

In addition to transients that are caused by normal SRAM operation, power cycling can generate negative voltage spikes on V_{CC} that drive it to values below V_{SS} by as much as one volt. These negative spikes can cause data corruption in the SRAM while in battery backup mode. To protect from these voltage spikes, STMicroelectronics recommends connecting a schottky diode from V_{CC} to V_{SS} (cathode connected to V_{CC} , anode to V_{SS}). Schottky diode 1N5817 is recommended for through hole and MBR5120T3 is recommended for surface mount.

Figure 10. Supply voltage protection

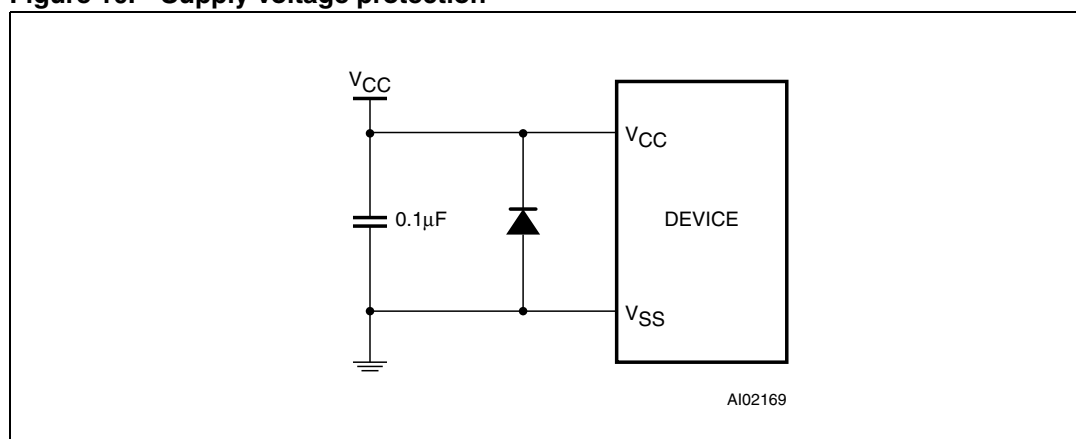

4 Tamper detection

4.1 Physical

There are four (4) high-impedance physical tamper detect input pins, 2 normally set to high (NH) and 2 normally set to low (NL). Each input is designed with a glitch immunity (see [Table 7 on page 28](#)). These inputs can be connected externally to several types of actuator devices (e.g., switches, wire mesh). A tamper on any one of the four inputs that causes its state to change will trigger the security alarm ($\overline{\text{SAL}}$) and drive it to active-low. Once the tamper condition no longer exists, the $\overline{\text{SAL}}$ will return to its normal high state.

TP₁ and TP₃ are set normally to high (NH). They are connected externally through a closed switch or a high-impedance resistor to V_{OUT} (in the case of STM1403A) or V_{TPU} (in the case of STM1403B/C). A tamper condition will be detected when the input pin is pulled low (see [Figure 5](#) and [Figure 6](#)). If not used, tie the pin to V_{OUT} or V_{TPU}.

TP₂ and TP₄ are set normally to low (NL). They are connected externally through a high-impedance resistor or a closed switch to V_{SS}. A tamper condition will be detected when the input pin is pulled high (see [Figure 7](#) and [Figure 8](#)). If not used, tie the pin to V_{SS}.

4.2 Supply voltage

The internally switched supply voltage, V_{INT} (either V_{CC} input or V_{BAT} input) is continuously monitored. If V_{INT} should exceed the over voltage trip point, V_{HV} (set at 4.2V, typical), or should go below the under voltage trip point, V_{LV} (set at 2.0 V, typical). $\overline{\text{SAL}}$ will be driven active-low. Once the tamper condition no longer exists, the $\overline{\text{SAL}}$ pin will return to its normal high state.

When no tamper condition exists, $\overline{\text{SAL}}$ is normally high (see [Section 2: Pin descriptions on page 11](#)).

When a tamper is detected, the $\overline{\text{SAL}}$ is activated (driven low), independent of the part type. V_{OUT} can be driven to one of three states, depending on which variant of STM1403 is being used (see [Table 1: Device summary on page 1](#)):

- ON
- High-Z or
- Ground (V_{SS})

Note: The STM1403 must be initially powered above V_{RST} to enable the tamper detection alarms. For example, if the battery is on while V_{CC} = 0V, no alarm condition can be detected until V_{CC} rises above V_{RST} (and t_{rec} expires). From this point on, alarms can be detected either on battery or V_{CC}. This is done to avoid false alarms when the device goes from no power to its operational state.

5 Typical operating characteristics

Note: Typical values are at $T_A = 25^\circ\text{C}$.

Figure 11. V_{BAT} -to- V_{OUT} on-resistance vs. temperature

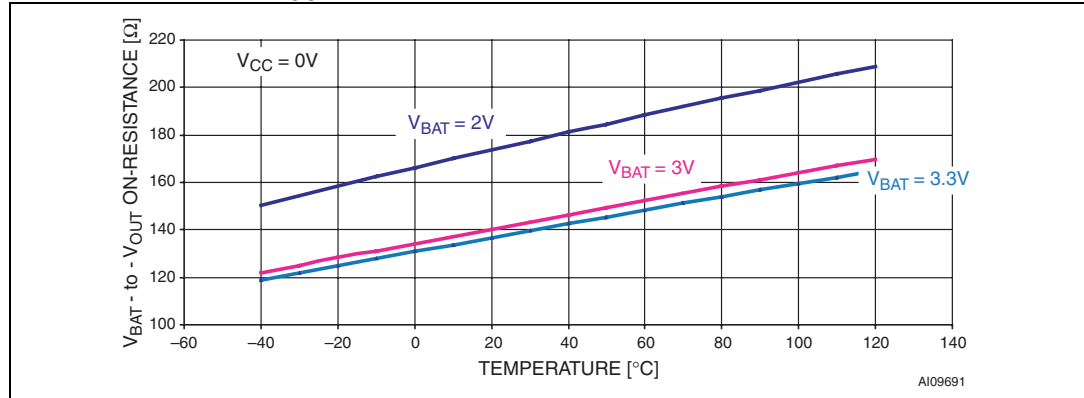

Figure 12. Supply current vs. temperature (no load)

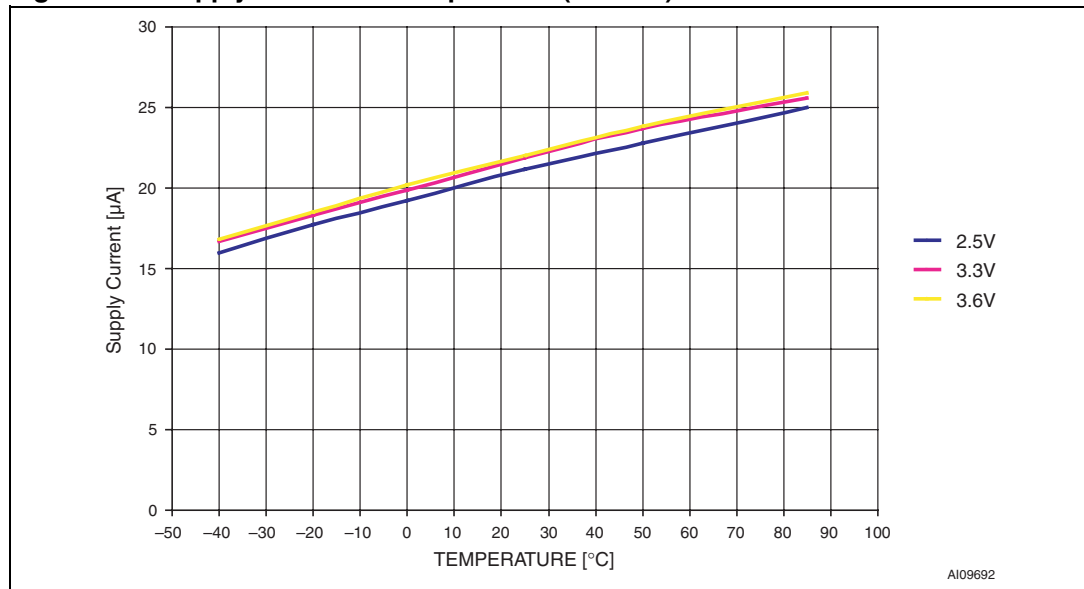

Figure 13. V_{PFI} threshold vs. temperature

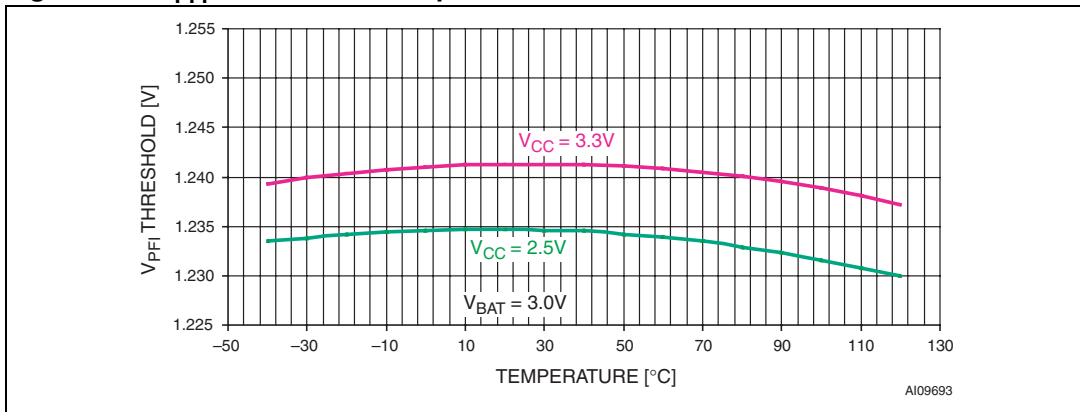

Figure 14. Reset comparator propagation delay vs. temperature

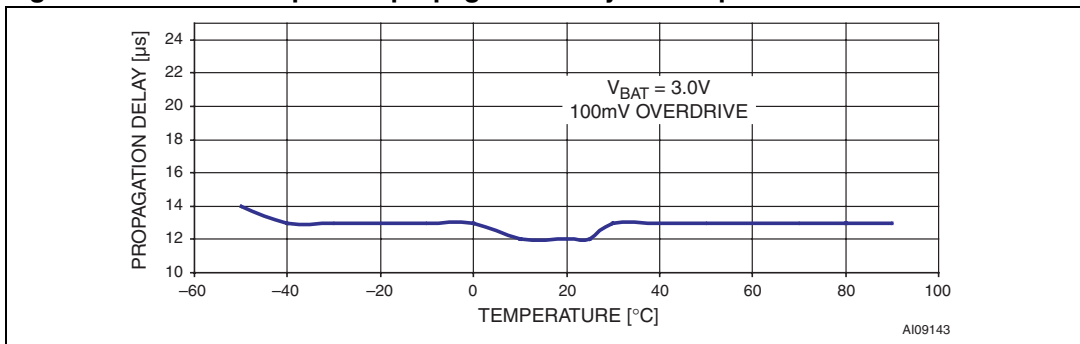

Figure 15. Power-up t_{rec} vs. temperature

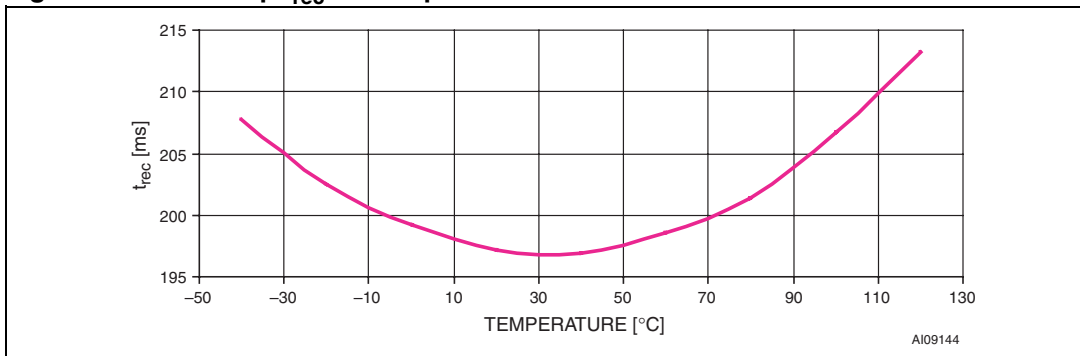

Figure 16. Normalized reset threshold vs. temperature

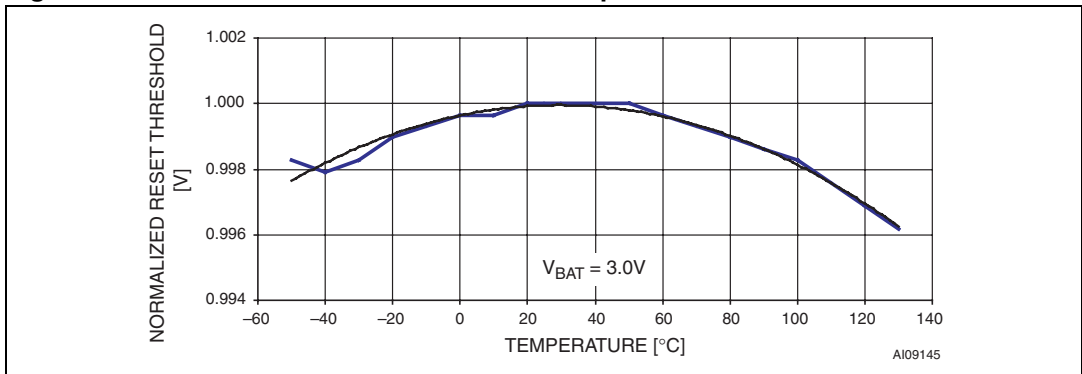

Figure 17. PFI to $\overline{\text{PFO}}$ propagation delay vs. temperature

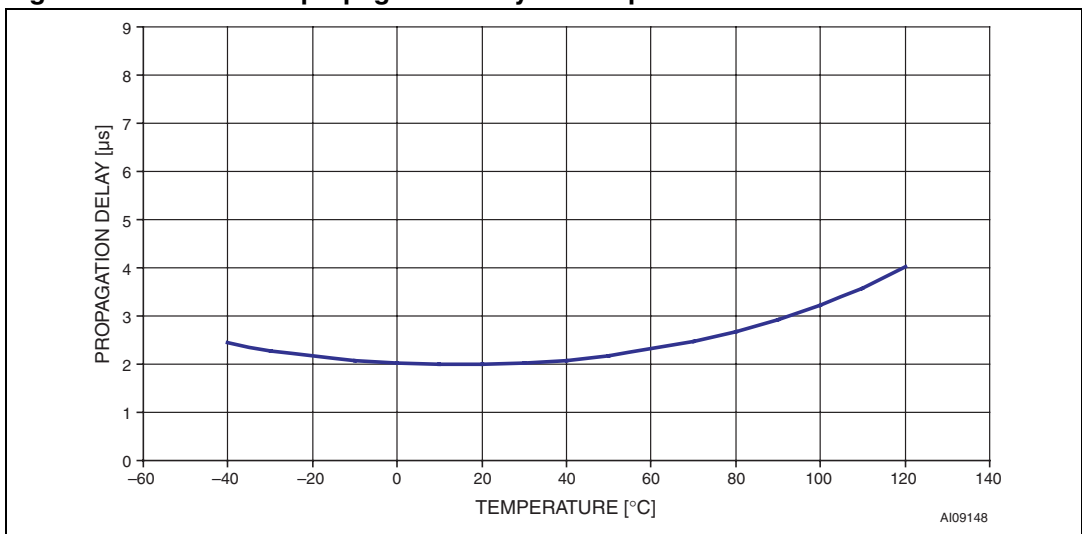

Figure 18. $\overline{\text{RST}}$ output voltage vs. supply voltage

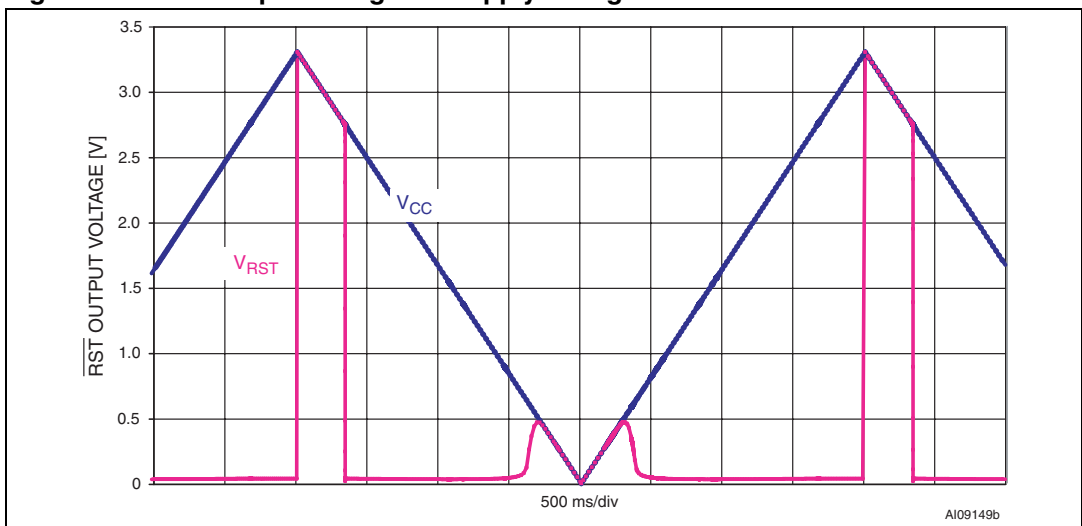

Figure 19. $\overline{\text{RST}}$ response time (assertion)

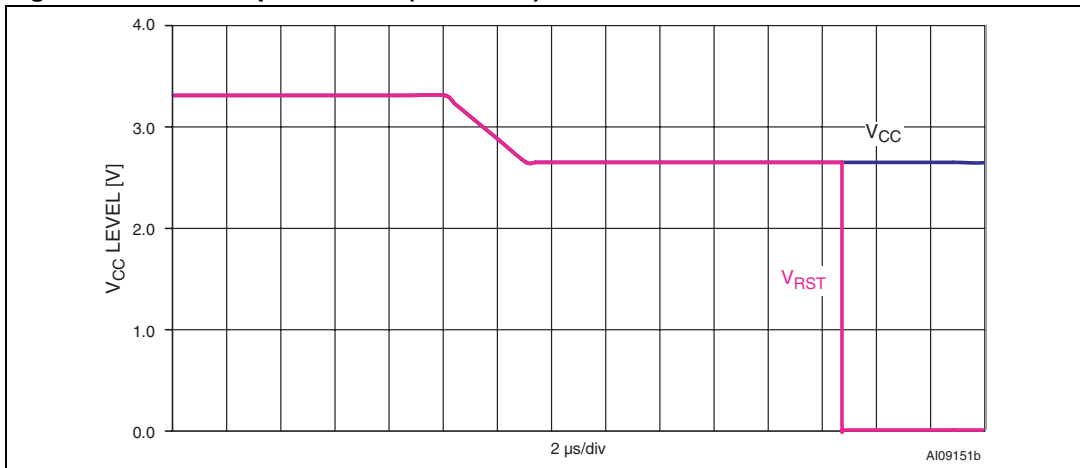

Figure 20. Power-fail comparator response time (assertion)

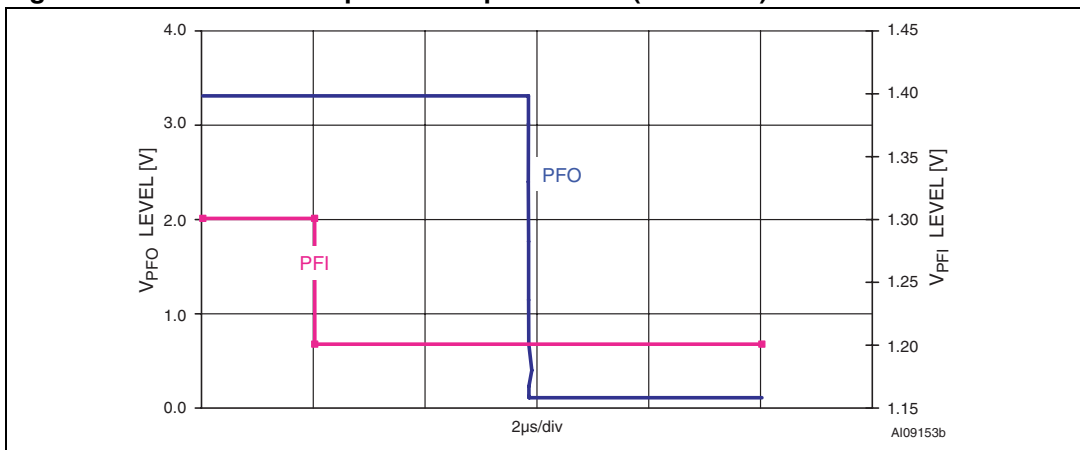

Figure 21. Power-fail comparator response time (de-assertion)

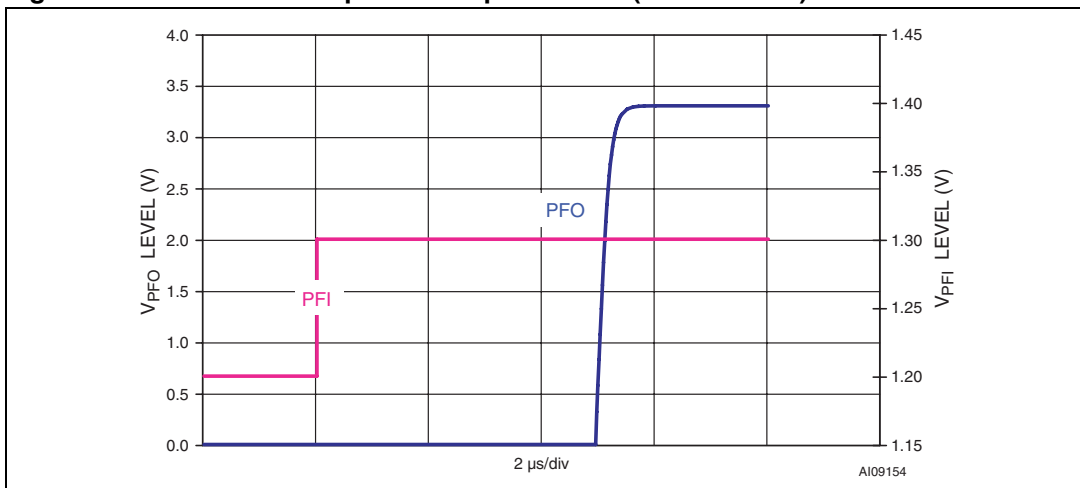

Figure 22. V_{CC} to reset propagation delay vs. temperature

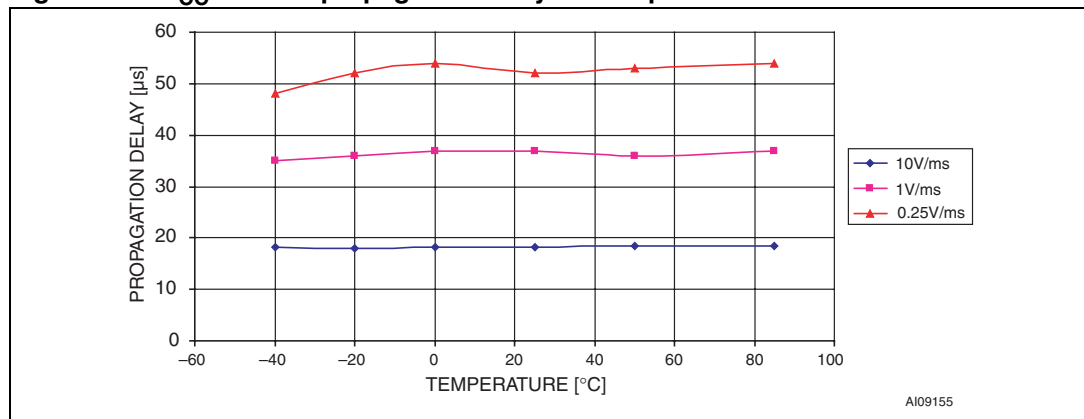
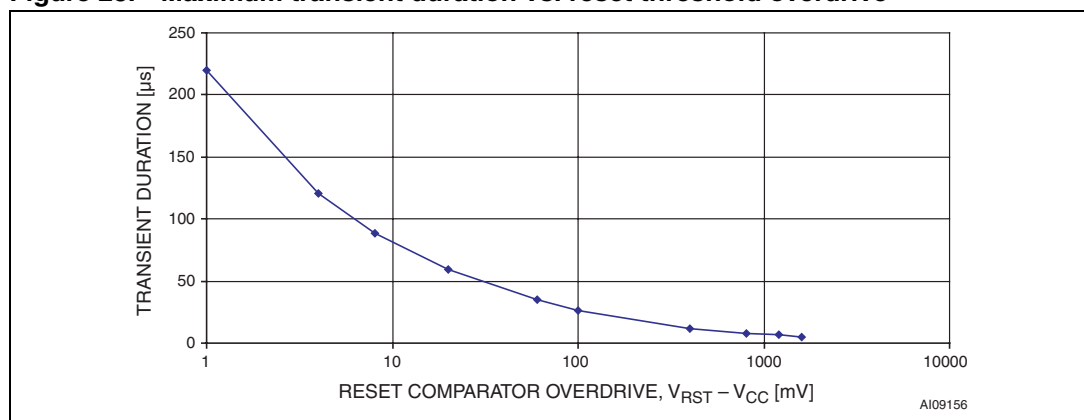

Figure 23. Maximum transient duration vs. reset threshold overdrive



6 Maximum ratings

Stressing the device above the rating listed in the absolute maximum ratings table may cause permanent damage to the device. These are stress ratings only and operation of the device at these or any other conditions above those indicated in the Operating sections of this specification is not implied. Exposure to absolute maximum rating conditions for extended periods may affect device reliability. Refer also to the STMicroelectronics SURE Program and other relevant quality documents.

Table 4. Absolute maximum ratings

| Symbol | Parameter | Value | Unit |
|------------------|--|------------------------|------|
| T_{STG} | Storage temperature (V_{CC} off, V_{BAT} off) | -55 to 150 | °C |
| $T_{SLD}^{(1)}$ | Lead solder temperature for 10 seconds | 260 | °C |
| V_{IO} | Input or output voltage | -0.3 to $V_{CC} + 0.3$ | V |
| V_{CC}/V_{BAT} | Supply voltage | -0.3 to 4.5 | V |
| I_O | Output current | 20 | mA |
| P_D | Power dissipation | 320 | mW |

Note: Reflow at peak temperature of 255°C to 260°C for < 30 seconds (total thermal budget not to exceed 180°C for between 90 to 150 seconds).

7 DC and AC parameters

This section summarizes the operating measurement conditions, and the DC and AC characteristics of the device. The parameters in the DC and AC characteristics Tables that follow, are derived from tests performed under the Measurement Conditions summarized in [Table 5: Operating and AC measurement condition](#). Designers should check that the operating conditions in their circuit match the operating conditions when relying on the quoted parameters.

Table 5. Operating and AC measurement condition

| Parameter | STM1403 | Unit |
|---|--------------------|------|
| V_{CC}/V_{BAT} supply voltage | 2.2 to 3.6 | V |
| Ambient operating temperature (T_A) | -40 to 85 | °C |
| Input rise and fall times | ≤ 5 | ns |
| Input pulse voltages | 0.2 to $0.8V_{CC}$ | V |
| Input and output timing ref. voltages | 0.3 to $0.7V_{CC}$ | V |

Figure 24. AC testing input/output waveforms

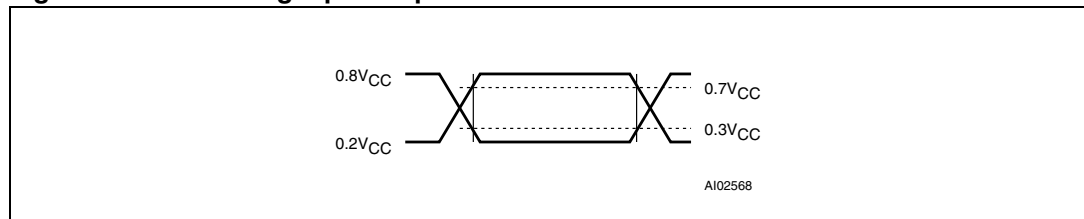

Figure 25. MR timing waveform

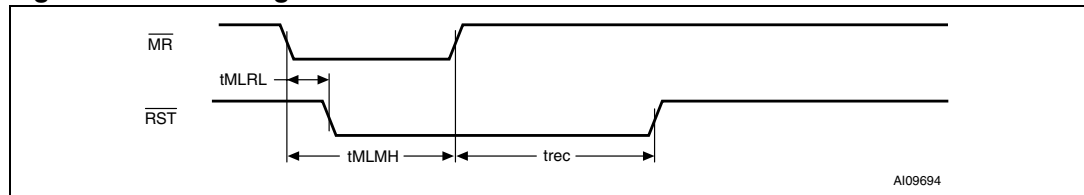

Figure 26. STM1403 switchover diagram, condition A ($V_{BAT} < V_{SW}$)

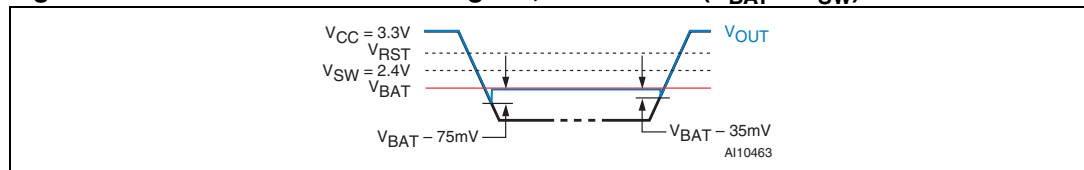

Figure 27. STM1403 switchover diagram, condition B ($V_{BAT} > V_{SW}$)

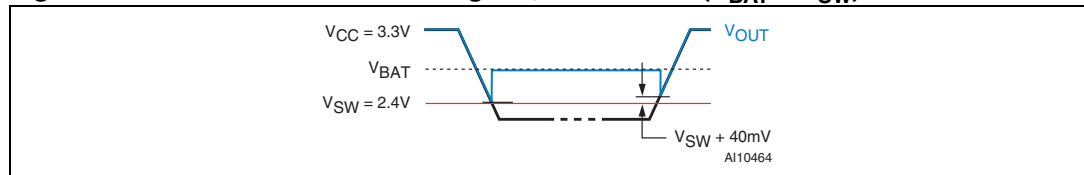

Table 6. DC and AC characteristics

| Sym | Alternative | Description | Test condition ⁽¹⁾ | Min | Typ | Max | Unit |
|--|-------------|---|---|---|-------------------|-------------|---------------|
| V_{CC} , V_{BAT} ⁽²⁾ | | Operating voltage | $T_A = -40$ to $+85^\circ\text{C}$ | 2.2 | | 3.6 | V |
| I_{CC} | | V_{CC} supply current (STM1403A) | Typ @ 3.3 V, 25°C | | 45 | 60 | μA |
| | | V_{CC} supply current (STM1403B,C) | | | 30 | 45 | μA |
| | | V_{CC} supply current in battery backup mode | | Excluding I_{OUT} ($V_{BAT} = 2.3$ V, $V_{CC} = 2.0$ V, $MR = V_{CC}$) | | 25 | 35 |
| I_{BAT} ⁽³⁾ | | V_{BAT} supply current in battery backup mode | Excluding I_{OUT} ($V_{BAT} = 3.6$ V) | | 2.8 | 4.0 | μA |
| V_{OUT1} | | V_{OUT} voltage (active) | $I_{OUT1} = 5$ mA ⁽⁴⁾ ($V_{CC} > V_{SW}$) | $V_{CC} - 0.03$ | $V_{CC} - 0.015$ | | V |
| | | | $I_{OUT1} = 80$ mA ($V_{CC} > V_{SW}$) | $V_{CC} - 0.3$ | $V_{CC} - 0.15$ | | V |
| | | | $I_{OUT1} = 250$ μA , $V_{CC} > V_{SW}$ ⁽⁴⁾ | $V_{CC} - 0.0015$ | $V_{CC} - 0.0006$ | | V |
| V_{OUT2} | | V_{OUT} voltage (battery backup) | $I_{OUT2} = 250$ μA , $V_{BAT} = 2.2$ V | $V_{BAT} - 0.1$ | $V_{BAT} - 0.04$ | | V |
| | | | $I_{OUT2} = 1$ mA, $V_{BAT} = 2.2$ V | | $V_{BAT} - 0.16$ | | V |
| V_{TPU1} | | Internal switched supply voltage (active) | $I_{SOURCE} = 500$ μA ($V_{CC} > V_{SW}$) | $V_{CC} - 0.3$ | | | V |
| V_{TPU2} | | Internal switched supply voltage (battery backup) | $I_{SOURCE} = 100$ μA ($V_{BAT} = 2.2$ V) | | $V_{BAT} - 0.10$ | | V |
| I_{LI} | | Input leakage current (\overline{MR}) | $\overline{MR} = 0$ V; $V_{CC} = 3$ V | 20 | 75 | 350 | μA |
| | | Input leakage current (PFI) | 0 V = $V_{IN} = V_{CC}$ | -25 | 2 | +25 | nA |
| | | Input leakage current (TP1-TP4) | 0 V = $V_{IN} = V_{CC}$ | -1 | | +1 | μA |
| I_{LO} | | Output leakage current | 0 V = $V_{IN} = V_{CC}$ ⁽⁵⁾ | -1 | | +1 | μA |
| V_{IH} | | Input high voltage (\overline{MR}) | $V_{RST}(\text{max}) < V_{CC} < 3.6\text{V}$ | $0.7V_{CC}$ | | | V |
| V_{IL} | | Input low voltage (\overline{MR}) | | | | $0.3V_{CC}$ | V |
| V_{OL} | | Output low voltage (\overline{PFO} , \overline{RST} , \overline{Vccsw} , \overline{SAL} , \overline{BLD}) | $V_{CC} = V_{RST}(\text{max})$, $I_{SINK} = 3.2\text{mA}$ | | | 0.3 | V |
| V_{OL} | | Output low voltage (\overline{RST}) | $I_{OL} = 40$ μA ; $V_{CC} = 1.0\text{V}$; $V_{BAT} = V_{CC}$; $T_A = 0^\circ\text{C}$ to 85°C | | | 0.3 | V |
| | | | $I_{OL} = 200$ μA ; $V_{CC} = 1.2\text{V}$; $V_{BAT} = V_{CC}$ | | | 0.3 | V |

Table 6. DC and AC characteristics (continued)

| Sym | Alternative | Description | Test condition ⁽¹⁾ | Min | Typ | Max | Unit |
|--|--|--|---|---------------------|------------------|-------|------------------------|
| V _{OHb} | | V _{OH} battery backup ($\overline{V_{CCSW}}$) | I _{SOURCE} = 100 μ A, | 0.8V _{BAT} | | | V |
| | | Pull-up supply voltage (open drain) | \overline{RST} , \overline{SAL} , \overline{BLD} , \overline{PFO} | | | 3.6 | V |
| Power-fail comparator | | | | | | | |
| V _{PFI} | | PFI input threshold | PFI falling (V _{CC} < 3.6 V) | 1.212 | 1.237 | 1.262 | V |
| | | PFI hysteresis | PFI Rising (V _{CC} < 3.6 V) | | 10 | 20 | mV |
| t _{PFD} | | PFI to \overline{PFO} propagation delay | | | 2 | | μ s |
| Battery switchover | | | | | | | |
| V _{SO} | Battery backup switchover voltage ⁽⁶⁾⁽⁷⁾ | Power-down | V _{BAT} > V _{SW} | | V _{SW} | | V |
| | | | V _{BAT} < V _{SW} | | V _{BAT} | | V |
| | | Power-up | V _{BAT} > V _{SW} | | V _{SW} | | V |
| | | | V _{BAT} < V _{SW} | | V _{BAT} | | V |
| | V _{SW} | | | | 2.4 | | V |
| | Hysteresis | | | | 40 | | mV |
| Battery low voltage detect | | | | | | | |
| V _{DET} | Battery detect threshold | On power-up only | M | 2.25 | 2.30 | 2.34 | V |
| | | | N | 2.45 | 2.50 | 2.55 | V |
| | | | O | 3.14 | 3.20 | 3.26 | V |
| Voltage reference (option for STM1403A)⁽⁸⁾ | | | | | | | |
| V _{REF} | Voltage reference (see Section 2.1.9: V_{REF} reference voltage output (1.237, typ) on page 12) | 0°C to 85°C | 1.212 | 1.237 | 1.262 | | V |
| | | -40° to 0°C | 1.200 | 1.237 | 1.274 | | V |
| I _{REF+} | Source current | 0°C to 85°C | 15 | 25 | | | μ A |
| | | -40° to 0°C | 10 | 15 | | | μ A |
| I _{REF-} | Sink current | | 10 | 13 | | | μ A |
| V _n | Output voltage noise | f = 100 Hz to 100 kHz | | 10-100 | | | μ V _{rms} |

Table 6. DC and AC characteristics (continued)

| Sym | Alternative | Description | Test condition ⁽¹⁾ | Min | Typ | Max | Unit | |
|--------------------------------|-------------|--|-------------------------------|------------------|------|-------|------|---|
| Reset thresholds | | | | | | | | |
| $V_{RST}^{(9)}$ | | Reset threshold | T | V_{CC} falling | 3.00 | 3.075 | 3.15 | V |
| | | | | V_{CC} rising | 3.00 | 3.085 | 3.17 | V |
| | | | S | V_{CC} falling | 2.85 | 2.925 | 3.00 | V |
| | | | | V_{CC} rising | 2.85 | 2.935 | 3.02 | V |
| | | | R | V_{CC} falling | 2.55 | 2.625 | 2.70 | V |
| | | | | V_{CC} rising | 2.55 | 2.635 | 2.72 | V |
| t_{rec} | | \overline{RST} pulse width | | 140 | 200 | 280 | ms | |
| Push-button reset input | | | | | | | | |
| t_{MLMH} | t_{MR} | \overline{MR} pulse width | | 100 | | | ns | |
| t_{MLRL} | t_{MRD} | \overline{MR} to \overline{RST} output delay | | | 60 | 500 | ns | |

- Valid for ambient operating temperature: $T_A = -40$ to 85°C ; $V_{CC} = V_{RST}$ (max) to 3.6 V; and $V_{BAT} = 2.8$ V (except where noted); typical values are for 3.3 V and 25°C .
- V_{CC} supply current, logic input leakage, push-button reset functionality, PFI functionality, state of \overline{RST} tested at $V_{BAT} = 3.6$ V, and $V_{CC} = 3.6$ V. The state of \overline{RST} and \overline{PFO} is tested at $V_{CC} = V_{CC}$ (min). V_{BAT} is voltage measured at the pin.
- Tested at $V_{BAT} = 3.6$ V, $V_{CC} = 3.5$ V and 0 V.
- Guaranteed by design.
- The leakage current measured on the \overline{RST} , \overline{SAL} , \overline{PFO} , and \overline{BLD} pins are tested with the output not asserted (output high impedance).
- When $V_{BAT} > V_{CC} > V_{SW}$, V_{OUT} remains connected to V_{CC} until V_{CC} drops below V_{SW} .
- When $V_{SW} > V_{CC} > V_{BAT}$, V_{OUT} remains connected to V_{CC} until V_{CC} drops below the battery voltage (V_{BAT}) – 75 mV.
- Maximum external capacitive load on V_{REF} pin cannot exceed 1nF.
- The reset threshold tolerance is wider for V_{CC} rising than for V_{CC} falling due to the 10 mV (typ) hysteresis, which prevents internal oscillation.

Table 7. Physical and environmental tamper detection levels

| Sym | Parameter | Test conditions ⁽¹⁾ | Min | Typ | Max | Unit |
|------------------|---|--|---|-----|---|------|
| V _{HV} | Overvoltage trip level | | 4.0 | 4.2 | 4.4 | V |
| V _{LV} | Undervoltage trip level | | 1.9 | 2.0 | 2.1 | V |
| | $\overline{\text{SAL}}$ propagation delay time (after over/under voltage detection) | V _{HV} + 200 mV or V _{LV} – 200 mV | | 25 | 50 | μs |
| V _{HTP} | Trip point for NH physical tamper input pins (TP ₁ or TP ₃) | | V _{OUT} – 1.3 V ⁽²⁾ | | V _{OUT} – 0.3 V ⁽²⁾ | V |
| V _{LTP} | Trip point for NL physical tamper input pins (TP ₂ or TP ₄) | | 0.3 | | 1.0 | V |
| | $\overline{\text{SAL}}$ propagation delay time ⁽³⁾ (after physical tamper pin detection) | V _{HTP} = V _{OUT} /V _{T_{TPU}} ; V _{LTP} = V _{SS} V _{DD} = 3.6 | | 30 | 50 | μs |
| | Physical tamper input (TP _X) glitch immunity | | | 15 | | μs |

- Valid for ambient operating temperature: T_A = –40 to 85°C; V_{CC} = V_{LV} to V_{HV} (except where noted).
- In the case of STM1403A, physical tamper input pins (TP_X) are referenced to V_{OUT} (pin 12). In the case of STM1403B or C, TP_X are referenced to V_{T_{TPU}} pin (pin 9).
- V_{CC} = V_{RST} (max) to 3.6 V

8 Package mechanical data

In order to meet environmental requirements, ST offers these devices in ECOPACK[®] packages. These packages have a Lead-free second level interconnect. The category of second Level Interconnect is marked on the package and on the inner box label, in compliance with JEDEC Standard JESD97.

The maximum ratings related to soldering conditions are also marked on the inner box label. ECOPACK is an ST trademark. ECOPACK specifications are available at: www.st.com.

Figure 28. QFN16 – 16-lead, quad, flat package, no lead, 3 x 3 mm body size, outline

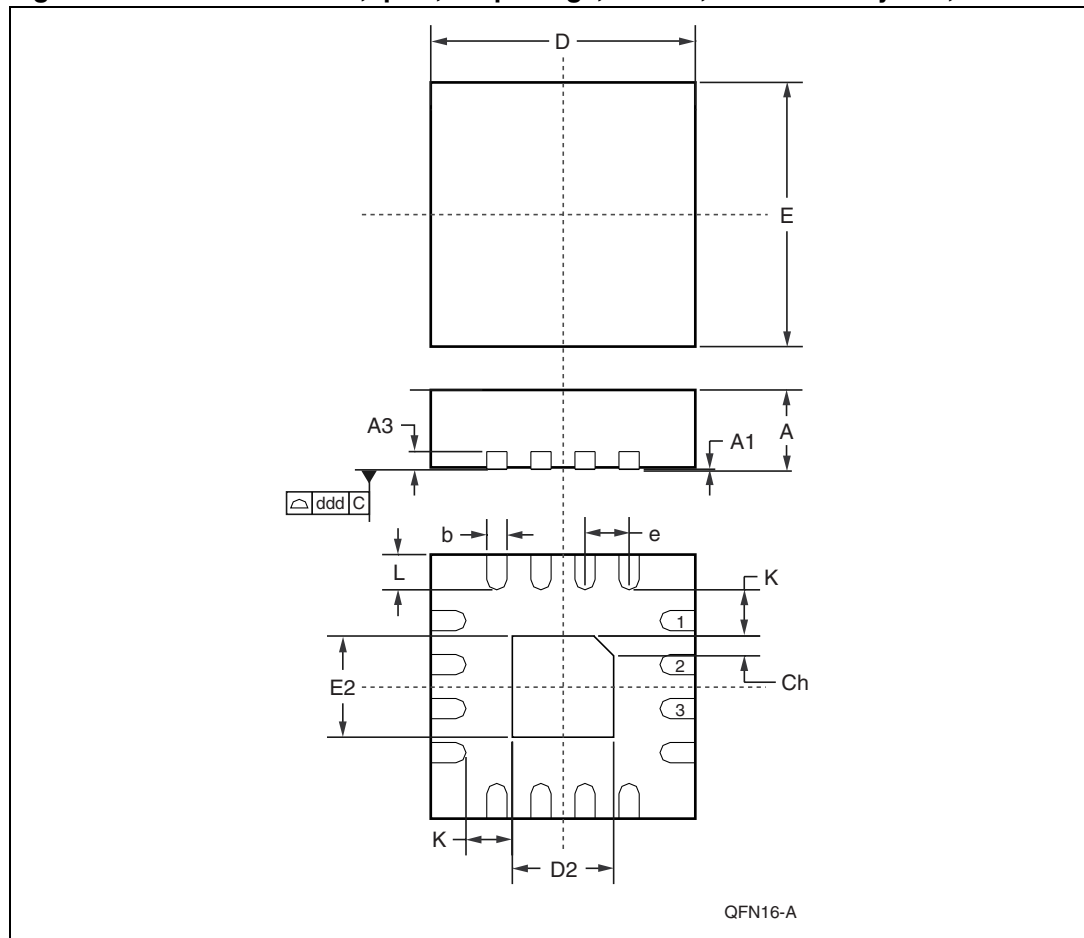

Note: Drawing is not to scale.

Table 8. QFN16 – 16-lead, quad, flat package, no lead, 3 x 3 mm body size, mechanical data

| Symb | mm | | | inches | | |
|------|------|------|------|--------|-------|-------|
| | Typ | Min | Max | Typ | Min | Max |
| A | 0.90 | 0.80 | 1.00 | 0.035 | 0.032 | 0.039 |
| A1 | 0.02 | 0.00 | 0.05 | 0.001 | 0.000 | 0.002 |
| A3 | 0.20 | – | – | 0.008 | – | – |
| b | 0.25 | 0.18 | 0.30 | 0.010 | 0.007 | 0.012 |
| D | 3.00 | 2.90 | 3.10 | 0.118 | 0.114 | 0.122 |
| D2 | 1.70 | 1.55 | 1.80 | 0.067 | 0.061 | 0.071 |
| E | 3.00 | 2.90 | 3.10 | 0.118 | 0.114 | 0.122 |
| E2 | 1.70 | 1.55 | 1.80 | 0.067 | 0.061 | 0.071 |
| e | 0.50 | – | – | 0.020 | – | – |
| K | 0.20 | – | – | 0.008 | – | – |
| L | 0.40 | 0.30 | 0.50 | 0.016 | 0.012 | 0.020 |
| ddd | – | 0.08 | – | – | 0.003 | – |
| Ch | – | 0.33 | – | – | 0.013 | – |
| N | 16 | | | 16 | | |

Figure 29. QFN16 – 16-lead, quad, flat package, no lead, 3 x 3 mm, recommended footprint

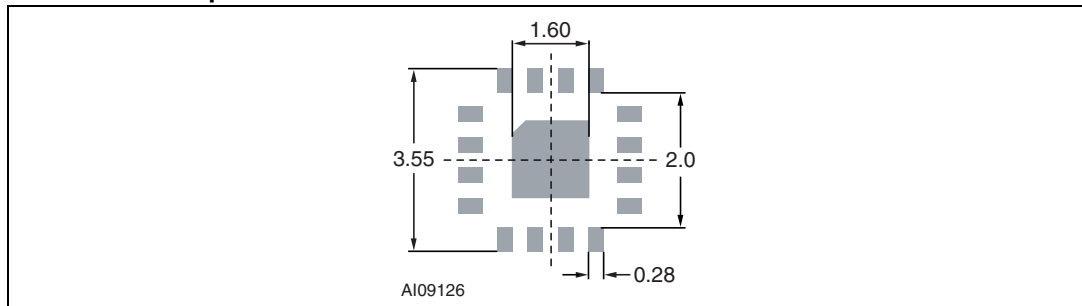

Note: Substrate pad should be tied to V_{SS} .

9 Part numbering

Table 9. Ordering information scheme (see [Figure 30 on page 32](#) for marking information)

| Example: | STM1403 | A | T | M | Q | 6 | F |
|---|---------|---|---|---|---|---|---|
| Device type | | | | | | | |
| STM1403: physical, voltage tamper detect | | | | | | | |
| V_{OUT} status ($\overline{\text{SAL}}$ = active-low) | | | | | | | |
| A: V _{OUT} = ON; $\overline{\text{Vccsw}}$ = normal mode | | | | | | | |
| B ⁽¹⁾ : V _{OUT} = High-Z; $\overline{\text{Vccsw}}$ = high | | | | | | | |
| C: V _{OUT} = ground; $\overline{\text{Vccsw}}$ = high | | | | | | | |
| Reset threshold voltage | | | | | | | |
| T: V _{RST} = 3.00 V to 3.15 V | | | | | | | |
| S: V _{RST} = 2.85 V to 3.00 V | | | | | | | |
| R: V _{RST} = 2.55 V to 2.70 V | | | | | | | |
| Battery low voltage detect threshold (V_{DET}) | | | | | | | |
| M: V _{DET} = 2.3 V (typ) | | | | | | | |
| N: V _{DET} = 2.5 V (typ) | | | | | | | |
| O: V _{DET} = 3.2 V (typ) | | | | | | | |
| Package | | | | | | | |
| Q = QFN16 (3 mm x 3 mm) | | | | | | | |
| Temperature range | | | | | | | |
| 6 = -40 to 85°C | | | | | | | |
| Shipping method | | | | | | | |
| F = ECOPACK [®] package, tape & reel | | | | | | | |

1. Contact local ST sales office for availability.

For other options, or for more information on any aspect of this device, please contact the ST sales office nearest you.

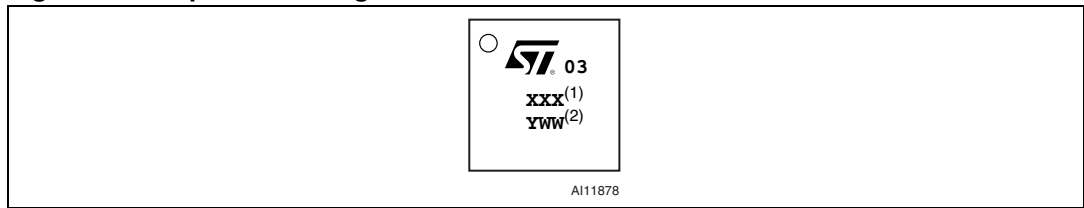
Figure 30. Topside marking information

1. Options codes:

X = A, B, or C (for V_{OUT})

X = T, S, or R (for reset threshold)

X = M, N, or O (for battery low voltage detect threshold)

2. Traceability codes

Y = Year

WW = Work Week

10 Revision history

Table 10. Document revision history

| Date | Revision | Changes |
|-------------|----------|---|
| 11-Oct-2004 | 1 | First edition |
| 26-Nov-2004 | 1.1 | Corrected footprint dimensions; update characteristics (Figure 1, 2, 3, 4, 5, 6, 7, 8, 26, 27, 29; Table 1, 2, 3, 6, 7) |
| 22-Dec-2004 | 1.2 | Update characteristics (Figure 4; Table 6, 7, 9) |
| 03-Feb-2005 | 1.3 | Update characteristics (Figure 4; Table 6, 7) |
| 25-Feb-2005 | 1.4 | Update temperature trip limits (Table 9) |
| 06-May-2005 | 1.5 | Update characteristics (Figure 3, 4, 28; Table 6, 7) |
| 05-Aug-2005 | 2 | Removed STM1404 references (Figure 1, 2, 3, 4, 5, 6, 7, 8, 26, 27; Table 1, 2, 5, 6, 7, 9) |
| 18-Oct-2005 | 3 | Update hardware hookup, characteristics, Lead-free text; add marking information (Figure 4, 30; Table 6, 7, 9) |
| 07-Feb-2007 | 4 | Update cover page, Table 7, and part numbering (Table 9). |
| 20-Aug-2008 | 5 | Minor formatting changes, updated Table 1 and 7. |

Please Read Carefully:

Information in this document is provided solely in connection with ST products. STMicroelectronics NV and its subsidiaries ("ST") reserve the right to make changes, corrections, modifications or improvements, to this document, and the products and services described herein at any time, without notice.

All ST products are sold pursuant to ST's terms and conditions of sale.

Purchasers are solely responsible for the choice, selection and use of the ST products and services described herein, and ST assumes no liability whatsoever relating to the choice, selection or use of the ST products and services described herein.

No license, express or implied, by estoppel or otherwise, to any intellectual property rights is granted under this document. If any part of this document refers to any third party products or services it shall not be deemed a license grant by ST for the use of such third party products or services, or any intellectual property contained therein or considered as a warranty covering the use in any manner whatsoever of such third party products or services or any intellectual property contained therein.

UNLESS OTHERWISE SET FORTH IN ST'S TERMS AND CONDITIONS OF SALE ST DISCLAIMS ANY EXPRESS OR IMPLIED WARRANTY WITH RESPECT TO THE USE AND/OR SALE OF ST PRODUCTS INCLUDING WITHOUT LIMITATION IMPLIED WARRANTIES OF MERCHANTABILITY, FITNESS FOR A PARTICULAR PURPOSE (AND THEIR EQUIVALENTS UNDER THE LAWS OF ANY JURISDICTION), OR INFRINGEMENT OF ANY PATENT, COPYRIGHT OR OTHER INTELLECTUAL PROPERTY RIGHT.

UNLESS EXPRESSLY APPROVED IN WRITING BY AN AUTHORIZED ST REPRESENTATIVE, ST PRODUCTS ARE NOT RECOMMENDED, AUTHORIZED OR WARRANTED FOR USE IN MILITARY, AIR CRAFT, SPACE, LIFE SAVING, OR LIFE SUSTAINING APPLICATIONS, NOR IN PRODUCTS OR SYSTEMS WHERE FAILURE OR MALFUNCTION MAY RESULT IN PERSONAL INJURY, DEATH, OR SEVERE PROPERTY OR ENVIRONMENTAL DAMAGE. ST PRODUCTS WHICH ARE NOT SPECIFIED AS "AUTOMOTIVE GRADE" MAY ONLY BE USED IN AUTOMOTIVE APPLICATIONS AT USER'S OWN RISK.

Resale of ST products with provisions different from the statements and/or technical features set forth in this document shall immediately void any warranty granted by ST for the ST product or service described herein and shall not create or extend in any manner whatsoever, any liability of ST.

ST and the ST logo are trademarks or registered trademarks of ST in various countries.

Information in this document supersedes and replaces all information previously supplied.

The ST logo is a registered trademark of STMicroelectronics. All other names are the property of their respective owners.

© 2008 STMicroelectronics - All rights reserved

STMicroelectronics group of companies

Australia - Belgium - Brazil - Canada - China - Czech Republic - Finland - France - Germany - Hong Kong - India - Israel - Italy - Japan - Malaysia - Malta - Morocco - Singapore - Spain - Sweden - Switzerland - United Kingdom - United States of America

www.st.com