

FEATURES

- 3 Year Warranty
- Low Cost, High Reliability
- Fixed Switching Frequency
- LED Indicator for Power On
- 100% Full Load Burn-In Tested
- Universal AC Input / Full Range
- Remote ON/OFF Control (Optional)
- Built-In Active PFC Function, PF > 0.93
- Built-In Constant Current Limiting Circuit
- Soft Start Circuit, Limiting AC Surge Current
- Short Circuit, Overload, and Over Voltage Protected



SPECIFICATIONS: PSSP100 Series

All specifications are based on 25°C, Nominal Input Voltage, and Maximum Output Current unless otherwise noted.
 We reserve the right to change specifications based on technological advances.

INPUT SPECIFICATIONS	
Input Voltage Range	85 ~ 264VAC (120 ~ 370VDC)
Input Frequency	47 to 63Hz
AC Current (typical)	1.7A @ 115VAC 0.8A @ 230VAC
Inrush Current (typical)	Cold Start 30A @ 230VAC
Leakage Current	< 2mA @ 240VAC
Power Factor (typical)	PF > 0.93 @ 230VAC PF > 0.98 @ 115VAC and full load
Remote ON/OFF Control (Option)	CN1: 4~10VDC Power On, <0 ~ 0.8VDC Power Off
OUTPUT SPECIFICATIONS	
Output Voltage	See Table
Output Power	See Table
Voltage Tolerance (See Note 3)	3.3V - 15V outputs: 2.0%; 24V - 48V outputs: 1.0%
Voltage Adjustment Range	See Table
Line Regulation	0.5%
Load Regulation	3.3V - 7.5V outputs: 1.0%; 12V - 48V outputs: 0.5%
Output Current	See Table
Ripple & Noise (max) (See Note 2)	3.3V - 15V outputs: 100mVp-p; 24V & 27V outputs: 150mVp-p; 48V output: 250mVp-p
Setup, Rise Time	600ms, 30ms @ full load
Hold Up Time (typical)	20ms @ full load
Temperature Coefficient	±0.05%/°C (0 ~ 50°C)
PROTECTION	
Overload Protection	105 ~ 150% rated output power Protection Type: Constant current limiting; recovers automatically after fault condition is removed
Over Voltage	See Table Protection Type: Shutdown output voltage, re-power on to recover.
GENERAL SPECIFICATIONS	
Switching Frequency	PFC: 67KHz PWM: 134KHz
Efficiency (typical)	See Table
Withstand Voltage	3000VAC (Input to Output), 1500VAC (Input to FG), 500VAC (Output to FG)
Isolation Resistance	100MΩ/500DC (Input to Output, Input to FG, and Output to FG)
ENVIRONMENTAL SPECIFICATIONS	
Working Temperature	-10°C to +60°C (refer to output load derating curve)
Storage Temperature	-20°C to +85°C
Working Humidity	20 ~ 90% RH non-condensing
Storage Humidity	10 ~ 95% RH
Vibration	10 ~ 500Hz, 2G 10min./1 cycle, 60min each along X, Y, Z axes.
MTBF	211,300 hours min. @ 25°C (MIL-HDBK-217F)
PHYSICAL SPECIFICATIONS	
Weight	600 grams
Dimensions	179(L) x 99(W) x 45(H) mm
Warranty	3 years
SAFETY & EMC	
Safety Standards	UL60950-1, TUV EN60950-1 approved
EMI Conduction & Radiation	Compliance to EN55022 (CISPR22) Class B
Harmonic Current	Compliance to EN61000-3-2,-3
EMS Immunity	Compliance to EN61000-4-2,3,4,5,6,8,11; ENV50204, EN55024, light industry level, criteria A

OUTPUT VOLTAGE / CURRENT RATING CHART

Model Number	Input Voltage	Output Voltage	Voltage Adjust. Range	Over Voltage Protection	Output Current	Output Power	Efficiency
PSSP100-3.3	85 ~ 264 VAC (120 ~ 370 VDC)	3.3 VDC	3.14 ~ 3.63V	3.63 ~ 4.46V	20A	66W	70%
PSSP100-5		5 VDC	4.75 ~ 5.5V	5.5 ~ 6.75V	20A	100W	76%
PSSP100-7.5		7.5 VDC	7.13 ~ 8.25V	8.25 ~ 10.13V	13.5A	101.25W	78%
PSSP100-12		12 VDC	11.4 ~ 13.2V	13.2 ~ 16.2V	8.5A	102W	80%
PSSP100-13.5		13.5 VDC	12.8 ~ 14.9V	14.85 ~ 18.23V	7.5A	101.25W	80%
PSSP100-15		15 VDC	14.3 ~ 16.5V	16.5 ~ 20.25V	6.7A	100.5W	82%
PSSP100-24		24 VDC	22.8 ~ 26.4V	26.4 ~ 32.4V	4.2A	100.8W	84%
PSSP100-27		27VDC	25.7 ~ 29.7V	29.7 ~ 36.45V	3.8A	102.6W	83%
PSSP100-48		48 VDC	45.6 ~ 52.8V	52.8 ~ 64.8V	2.1A	100.8W	82%

NOTES

1. All parameters NOT specially mentioned are measured at 230VAC input, rated load, and 25°C ambient temperature.
2. Ripple & noise are measured at 20MHz bandwidth by using a 12" twisted pair-wire terminated with a 0.1uF & 47uF parallel capacitor.
3. Tolerances include set up tolerance, line regulation, and load regulation.
4. The power supply is considered a component, which will be installed into final equipment. The final equipment must be re-confirmed that it still meets EMC directives.

BLOCK DIAGRAM

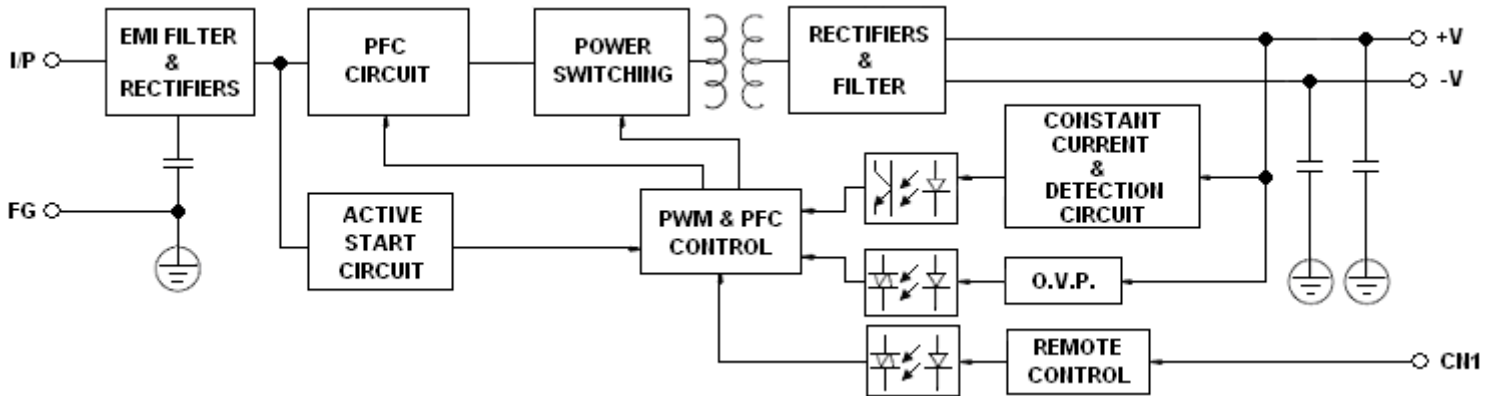

DERATING CURVE

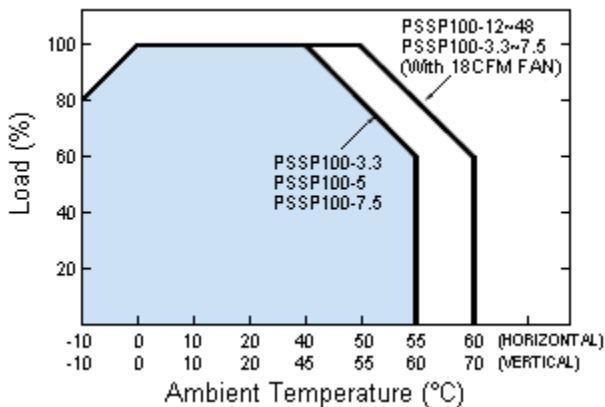

OUTPUT DERATING VS INPUT VOLTAGE

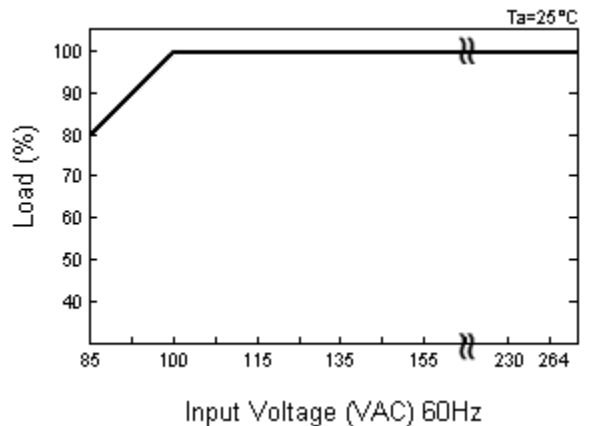

MECHANICAL DRAWING

Unit: mm

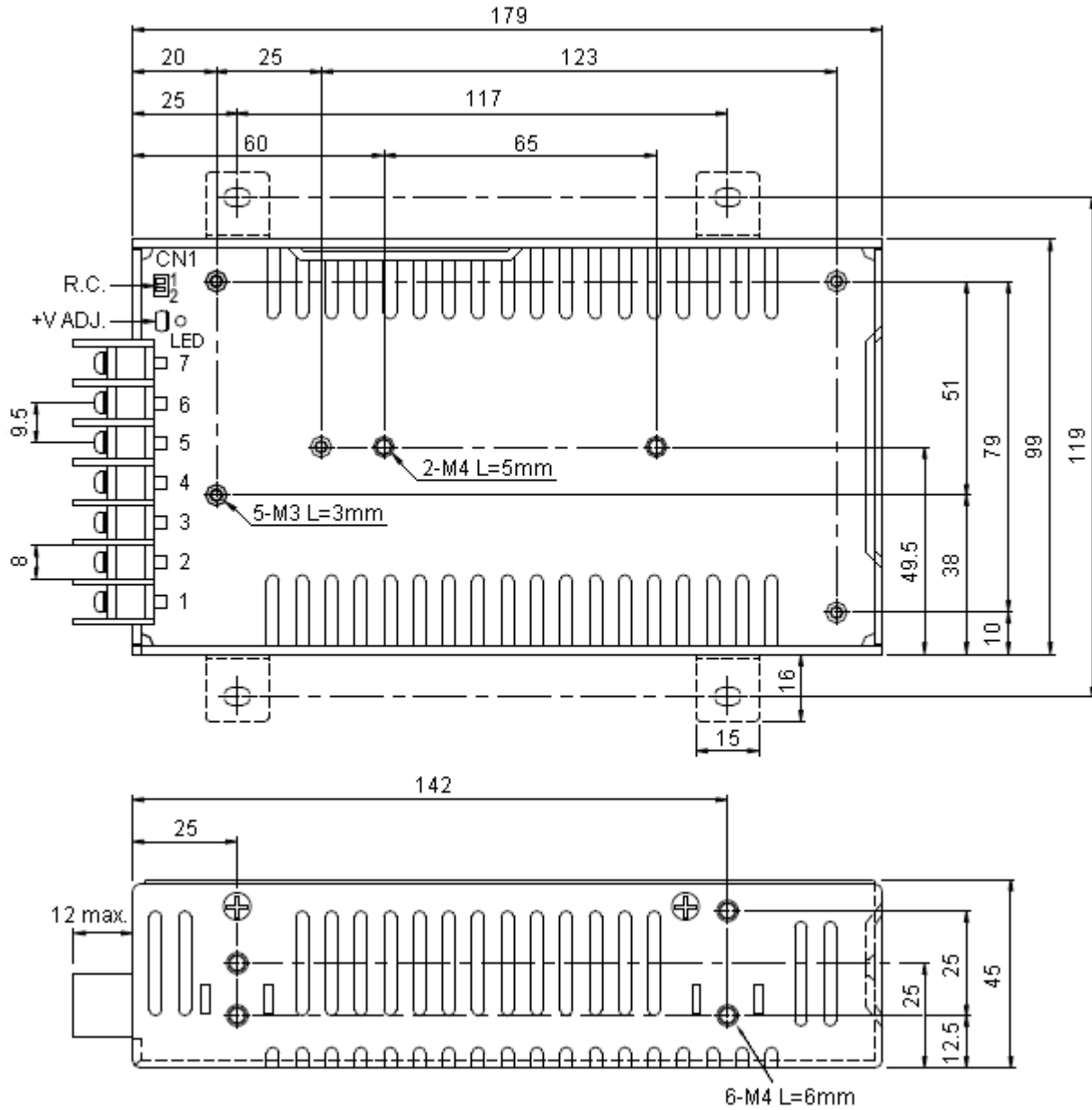

Terminal Pin No. Assignment

Pin No.	Assignment
1	AC/L
2	AC/N
3	FG
4,5	DC OUTPUT (-V)
6,7	DC OUTPUT (+V)

Remote ON/OFF (CN1): JST S2B-XH or equivalent (optional)

Pin No.	Assignment	Mating Housing	Terminal
1	RC+	JST XHP or equivalent	JST SXH-001T-P0.6 or equivalent
2	RC-		