

Super LLD II (For PFC circuit) (current discontinuous mode)

LOW LOSS SUPER HIGH SPEED RECTIFIER

■ Outline drawings, mm

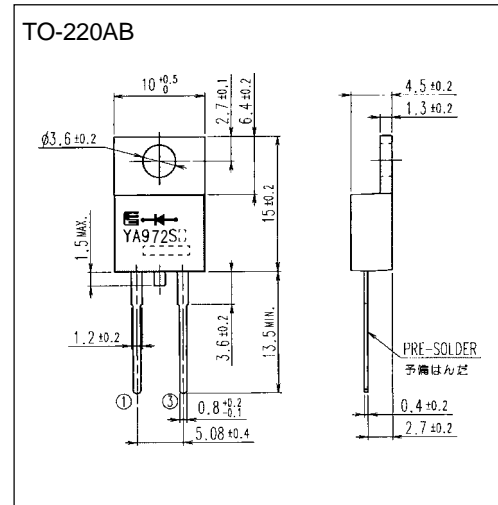

■ Features

- Super high speed switching
- High reliability by planer design

■ Applications

- PFC circuit (current continuous mode)

■ Connection diagram

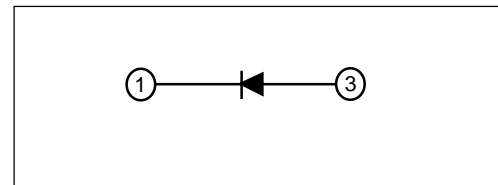

■ Maximum ratings and characteristics

● Maximum ratings

Item	Symbol	Conditions	Rating	Unit
Repetitive peak reverse voltage	V_{RRM}		600	V
Average output current	I_o	Square wave duty=1/2, $T_c=115^{\circ}C$	10	A
Non-Repetitive surge current	I_{FSM}	Sine wave 10ms, 1shot	100	A
Operating junction temperature	T_j		150	$^{\circ}C$
Storage temperature	T_{stg}		-40 to +150	$^{\circ}C$

● Electrical characteristics ($T_a=25^{\circ}C$ Unless otherwise specified)

Item	Symbol	Conditions	Characteristics	Unit
Forward voltage	V_F	$I_F=10A$	Max 1.55	V
Reverse current	I_R	$V_R=V_{RRM}$	Max. 10.0	μA
Reverse recovery time	t_{rr}	$I_F=0.1A, I_R=0.2A, I_{rec}=0.05A$	Max. 50.0	ns
Thermal resistance	$R_{th(j-c)}$	Junction to case	Max. 2.0	$^{\circ}C/W$

● Mechanical characteristics

Mounting torque	Recommended torque	0.3 to 0.5	N·m
Approximate mass		2.0	g

■ Characteristics

