

Single-Phase Full-Wave Motor Driver for Fan Motor

DESCRIPTION

EUM6179 is designed specifically for electronic commutation of single coil brushless DC motor applications. It is intended to be used as an interface between a HALL IC and a single coil motor. The functions built in EUM6179 are soft switched drive mode, fan tachometer, lock detection, automatic restart, thermal shut-down and Hall Bias.

Soft switched drive mode makes the output signal gentle when the amplitude of HALL signal is small. Oppositely, it makes the output signal steep when the amplitude of HALL signal is big. If the motor is stalled by external force or obstacles, overdrive current may incur coil overheat/burning. To prevent this, lock detection circuit can shut down the driver for 5 seconds after motor lockup. Then automatic restart circuit will try to power up the driver for 500ms every 5 seconds.

For different application, fan tachometer circuit has FG output for EUM6179 and FG/2 output for EUM6179A.

FEATURES

- Low Voltage 2.2V~6V
- Single-Phase Full-Wave driver System
- Soft switched drive
- Lock detection, Automatic restart
- Tachometer Output
FG output for EUM6179,
FG/2 output for EUM6179A
- Hall Bias
- Thermal Shutdown Protection
- FG Output
- RoHS Compliant and 100% Lead (Pb)-Free

APPLICATIONS

- NB FAN Motor

Application Circuit and Block Diagram

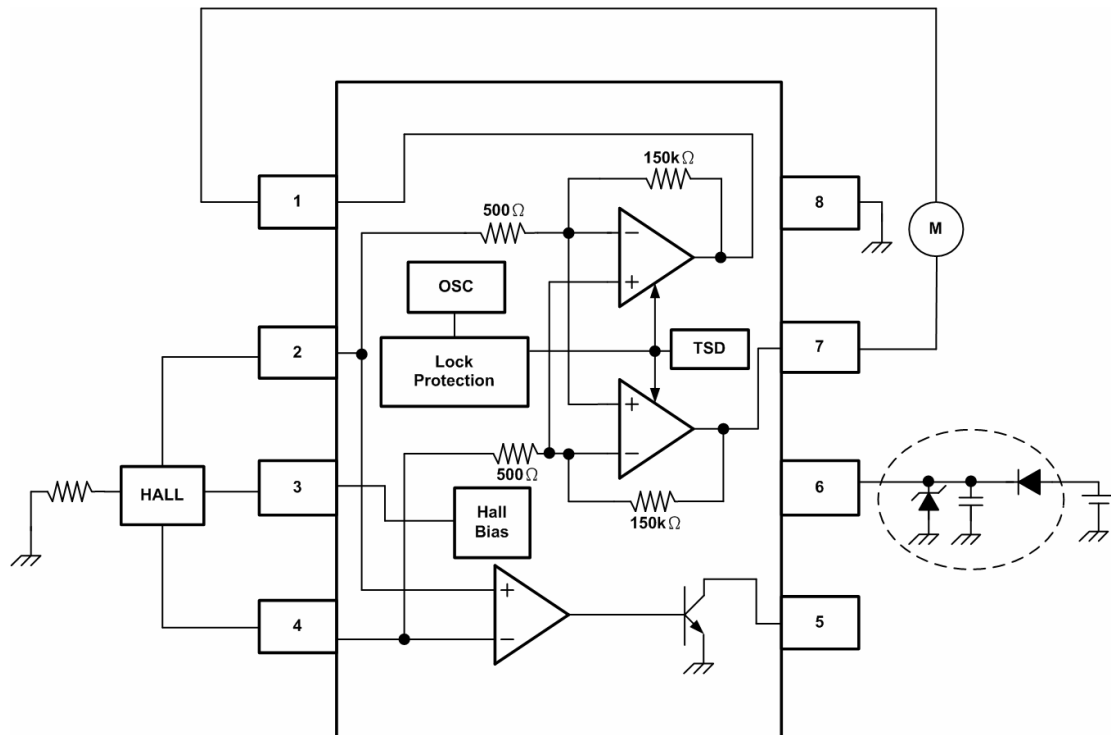

Figure 1.

Pin Configurations

Package Type	Pin Configurations
MSOP-8	

Pin Description

PIN	Pin	DESCRIPTION
OUT2	1	Motor output terminal
H+	2	Hall input terminal
HB	3	Hall bias terminal
H-	4	Hall input terminal
FG	5	Output pin of fan tachometer (open-collector) FG : EUM6179 (The frequency is the same as Hall input frequency) FG/2 : EUM6179A (The frequency is the half of Hall input frequency)
VCC	6	Power supply terminal
OUT1	7	Motor output terminal
GND	8	GROUND terminal

Power Dissipation

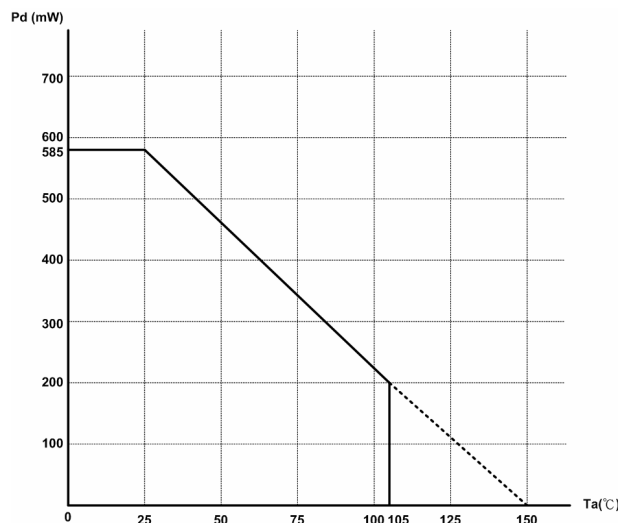

Figure 2.

To use at temperature above Ta=25 reduce 4.68mW/

Ordering Information

Order Number	Package Type	Marking	Operating Temperature range
EUM6179MIR1	MSOP-8	XXXX 6179	-40 °C to 105°C
EUM6179AMIR1	MSOP-8	XXXX 6179A	-40 °C to 105°C

EUM6179/A

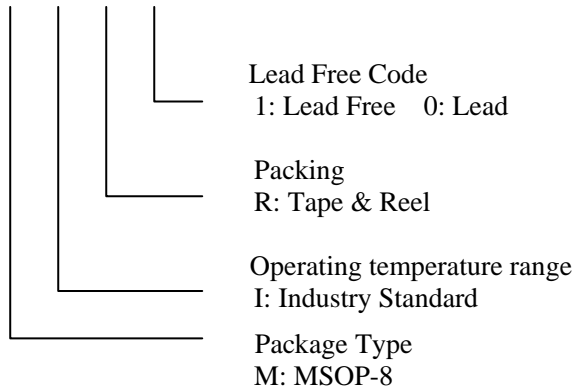

Absolute Maximum Ratings

- VCC ----- 7V
- I_{max} ----- 1000mA
- IFG ----- 5mA
- VFG----- 7V
- Power Dissipation----- 585mW
- Junction Temperature ----- 150°C
- Storage Temperature Range ----- -55°C to 150°C
- Lead Temperature (Soldering, 10sec.) ----- 260°C
- ESD Ratings
 - Human Body Mode ----- 1kV
 - Machine Mode ----- 300V

Recommended Operating Conditions

- Supply Voltage, V_{CC} ----- 2.2V to 6V
- Hall input voltage range----- 0.4 to V_{CC}-1.1V
- Operating Temperature Rang ----- -40°C to 105°C

Electrical Characteristics

(Unless otherwise specified TA =25°C, V_{CC} = 5V)

	Parameter	Conditions	Limit			Unit
			Min	Typ	Max.	
ICC	Supply Voltage		--	3.3	6	mA
Hall input						
VHOFS	Input offset voltage		--	--	±3	mV
Output						
VO	Output voltage	I _o =250mA Upper and Lower total	--	0.30	0.45	V
Gio	Input-output Gain		45	48	50	dB
FG signal output						
VFGL	FG low voltage	I _{FG} =3mA	--	--	0.3	V
VHYS	Input hysteresis voltage		±6	±10	±15	mV
Lock protection						
TON	Lock detection ON time		0.35	0.50	0.65	sec
TOFF	Lock detection OFF time		3.5	5.0	6.5	sec
Hall bias						
VHB	Hall bias voltage	I _{HB} =5mA	1.15	1.30	1.45	V

* This product is not designed for protection against radioactive rays.

Input Output Circuit

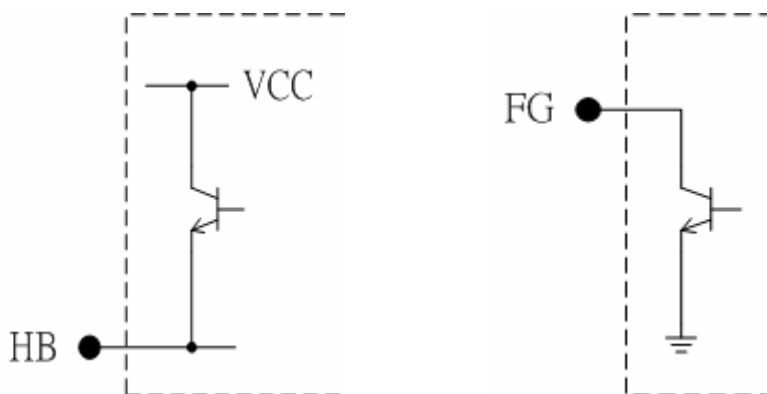
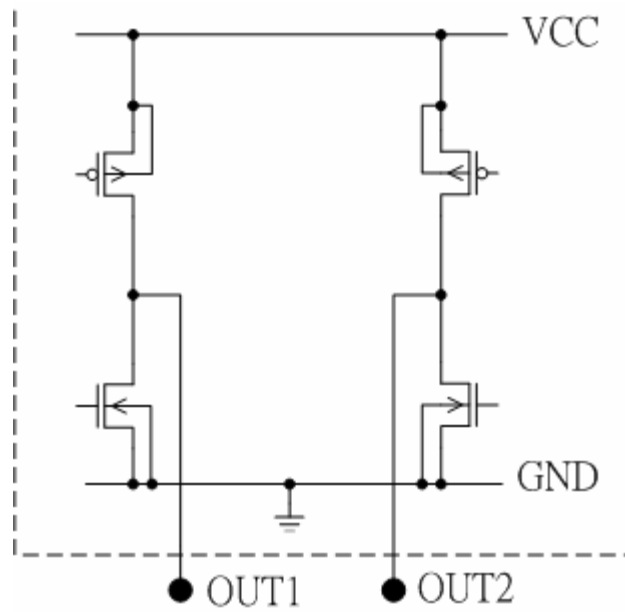
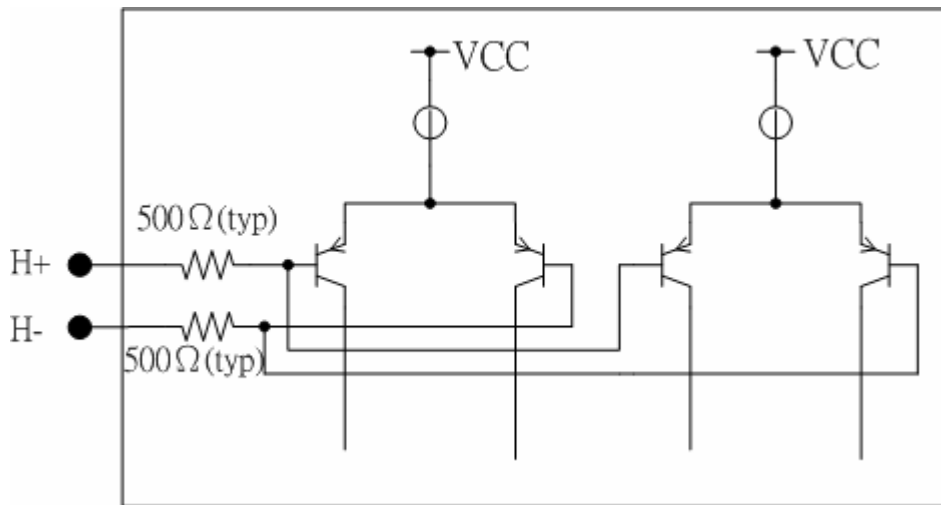

Supply Current

$V_{H+}=0.75V$

$V_{H-}=0.55V$

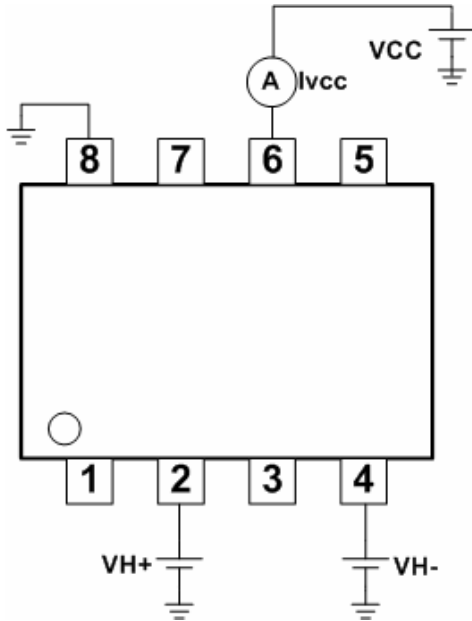

Input Offset Voltage

$V_{H+}=2.2V$

$V_{H-}=2.2V$

$$V_{HOFS}=(V_{OUT1}-V_{OUT2})/G_{IO}$$

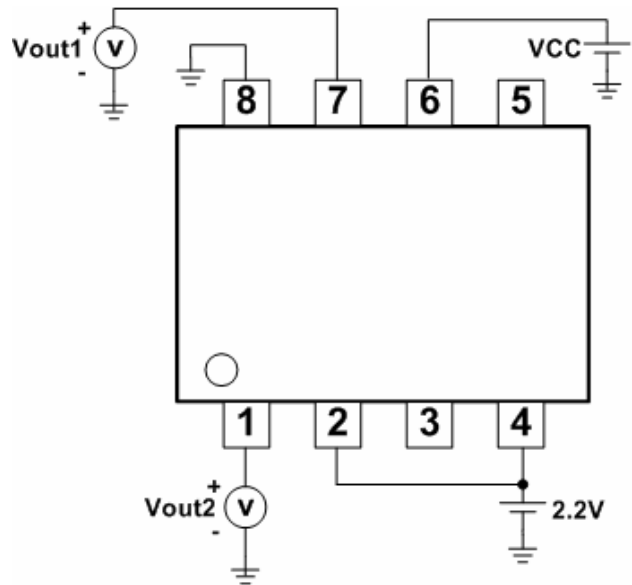

Output Voltage

$V_{H+}=0.75V$

$V_{H-}=0.55V$

$I_O=250mA$

$V_O =V_{oh}+V_{ol}$

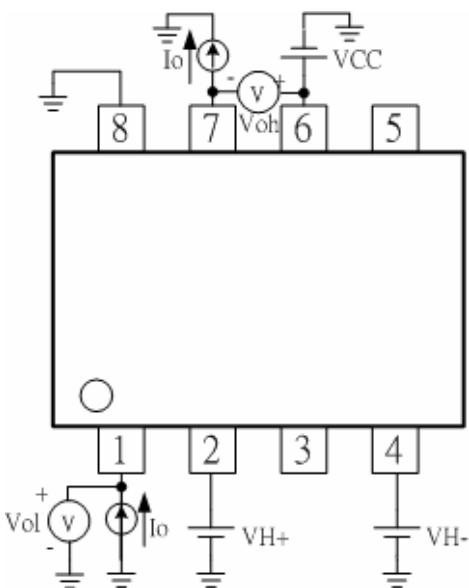

Output Voltage

$V_{H+}=0.55V$

$V_{H-}=0.75V$

$I_O=250mA$

$V_O =V_{oh}+V_{ol}$

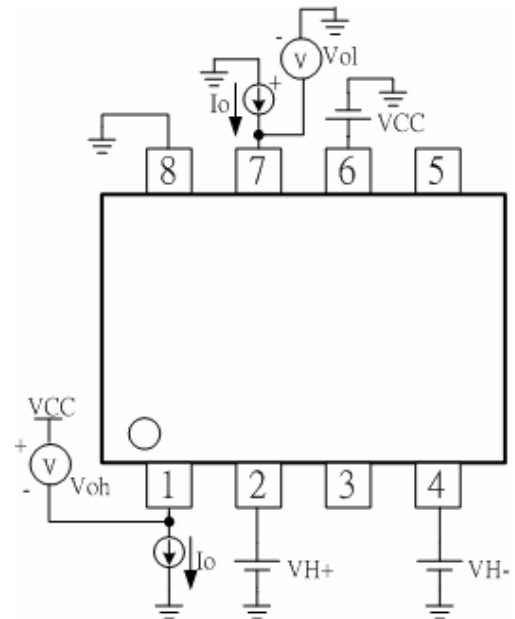

Input-Output Gain

STEP 1

$V_{H+} = V_{H-} = 2.2 \text{ V}$

Measure V1

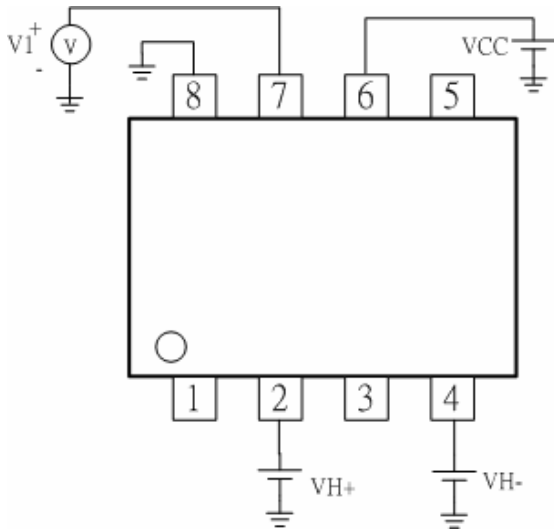

STEP 2

$V_{H+} = 2.2 \text{ V} + (2.2\text{V} - V1) / 300 + 0.001$

$V_{H-} = 2.2 \text{ V}$

Measure V2

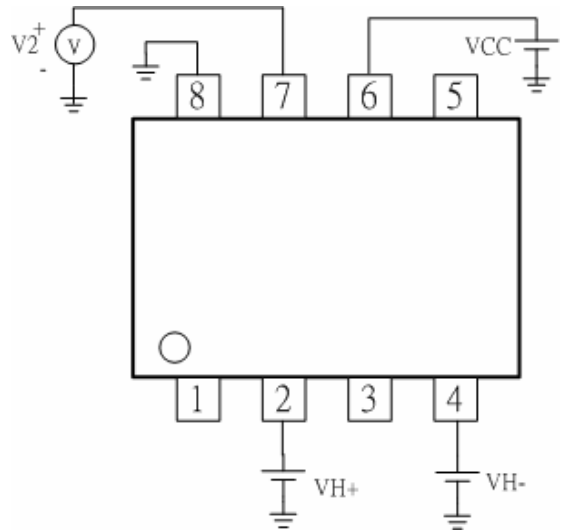

STEP 3

$V_{H+} = 2.2 \text{ V} + (2.2\text{V} - V1) / 300 + 0.001$

$V_{H-} = 2.2 \text{ V}$

Measure V3

$G_{IO} = 20 \log[(V2 - V3) / 0.002]$

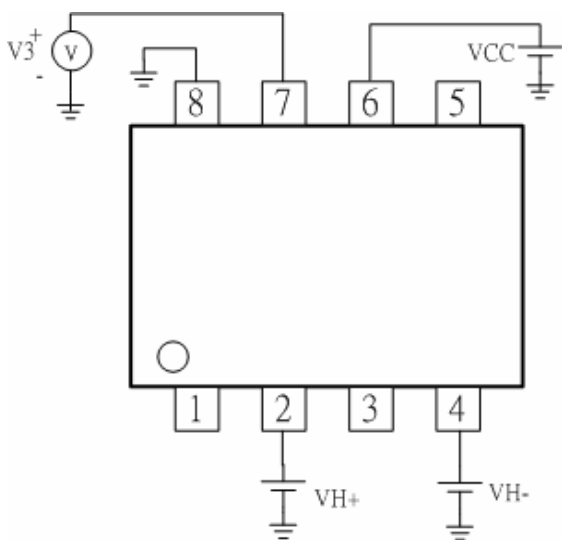

FG Low Voltage

$V_{H+} = 0.75 \text{ V}$

$V_{H-} = 0.55 \text{ V}$

$I_{FG} = 3 \text{ mA}$

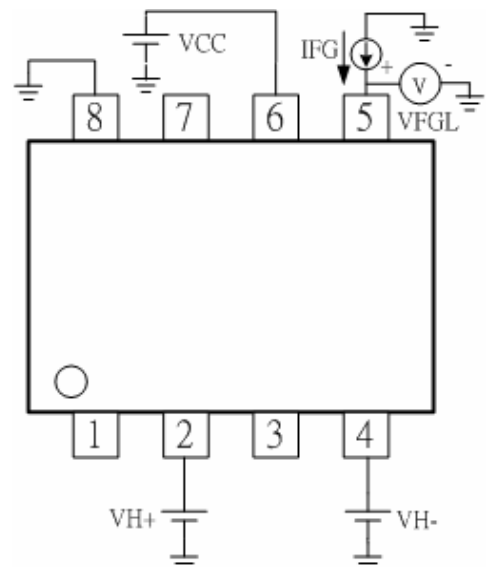

Input Hysteresis Voltage

Upper

$V_{H-} = 2.2\text{ V}$ $V_{H+} = 2.1\text{ V}$ $V_{FG} = \text{H}$

Sweep up V_{H+} when $V_{FG}:\text{H} \rightarrow \text{L}$

Measure V_{H+}

$V_{HYS} = V_{H+} - 2.2\text{ V}$

Lower

$V_{H-} = 2.2\text{ V}$ $V_{H+} = 2.3\text{ V}$ $V_{FG} = \text{H}$

Sweep up V_{H+} when $V_{FG}:\text{L} \rightarrow \text{H}$

Measure V_{H+}

$V_{HYS} = V_{H+} - 2.2\text{ V}$

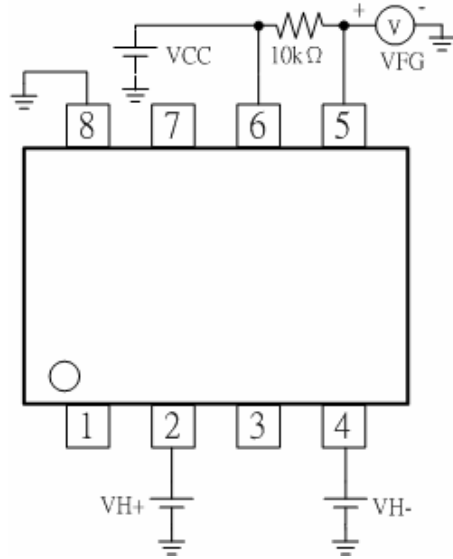

Lock Detection ON/OFF Time

$V_{H+} = 0.75\text{ V}$ $V_{H-} = 0.55\text{ V}$

Ton: the time $\text{OUT1} = \text{H}$

Toff: the time $\text{OUT1} = \text{L}$

($L < 0.1\text{ V}$, $4.95\text{ V} < H$)

Hall Bias Voltage

$V_{H+} = 0.55\text{ V}$

$V_{H-} = 0.75\text{ V}$

$I_{HB} = 5\text{ mA}$

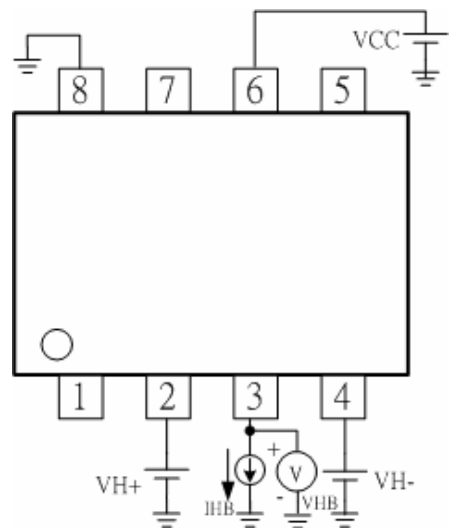
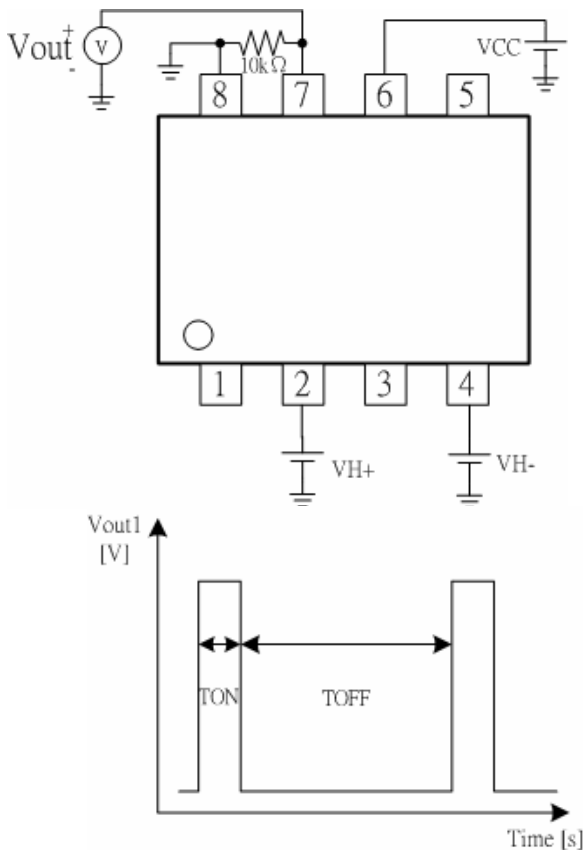

Notes

Absolute maximum ratings

This product is produced with strict quality control, but destroyed in using exceed the absolute maximum ratings. Once IC destroyed, failure mode cannot be defined (like short-mode or open-mode). Therefore, physical security countermeasure, like fuse, is to be given when a specific mode to exceed the absolute maximum ratings is considered.

GND potential

The GND terminal should be the location of the lowest voltage on the chip.

Thermal design

The thermal design should allow enough margin for actual power dissipation.

Mounting failures

Mounting failures, such as misdirection or mismount, may destroy the device. The electrical short caused by falling particle, between outputs; power supply and output; or output and ground, may damage the device.

Electromagnetic field

A strong electromagnetic field may cause malfunction.

ASO

Please consider output transistors not to exceed absolute maximum ratings and ASO.

Hall signal input terminals (H+, H-)

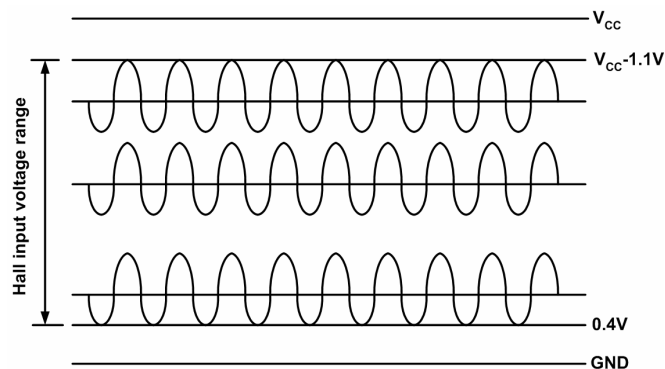

Figure 3. Hall input voltage range

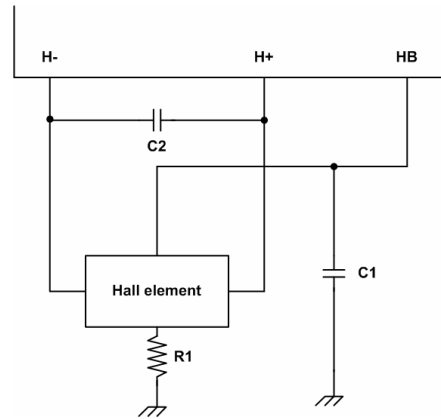

Figure 4.

Please adjust Hall input voltage by value of R1 so that hall signal contains amplitude input within range 0.4V~Vcc-1.1V. In case Vcc noise influence the hall signal by board wiring pattern, please connect capacitor C1 like Fig 4. In the case of long board wiring pattern from hall element to hall signal input terminal, please connect capacitor C2 like Fig 4.

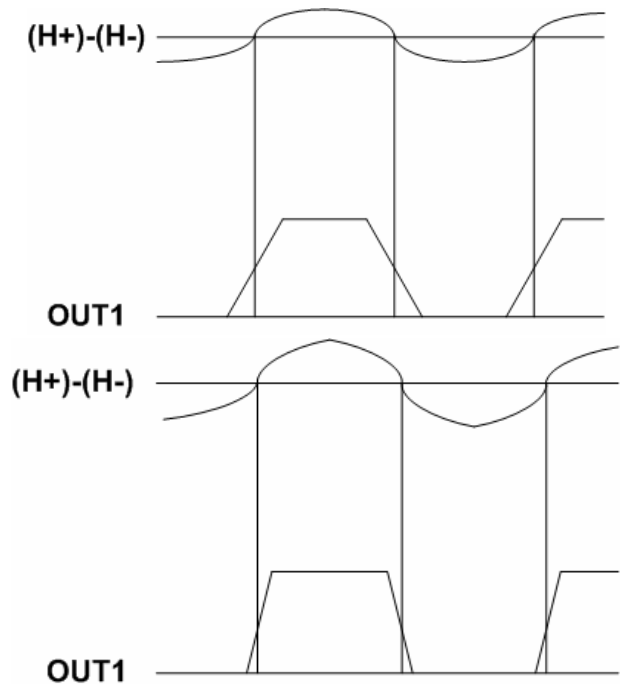

Figure 5. Difference of output signal depending on hall input signal

The output signal of this IC is the amplified hall input signal, therefore, the output signal depends on hall input signal. When the amplitude of hall signal is small, the output signal becomes gentle. Oppositely, the amplitude is big, the output signal becomes steep. The hall-input/output gain is about 300 times (TYP). So, please input the suitable signal to make an adequate amplitude of the output signal.

Thermal shut down (TSD)

This IC is built-in TSD.

TSD has the temperature hysteresis.

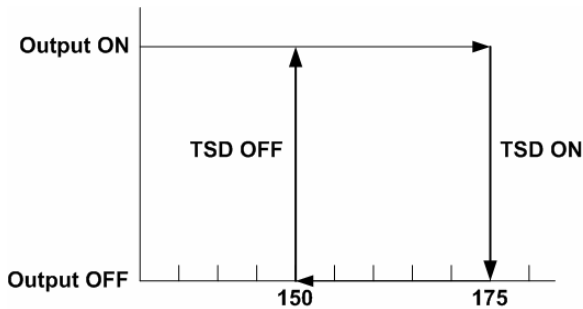

Figure 6. TSD

TSD ON (TYP. :175) All output transistor OFF.

TSD OFF (TYP. :150) Reset ordinary motion.

(It has the temperature hysteresis of 25 <TYP>)

Reverse connection of power supply

Reverse connection of power supply may break the device. A countermeasure is needed such as using reverse current protection diode between power supply and Vcc terminal.

Power supply line

The BEMF cause re-circulate current to power supply, Please connect a capacitor between power supply and GND as a route of re-circulate current. And please determine the capacitance after confirmation that the capacitance does not causes any problems.

Lock detection , automatic restart circuit

This IC detect the rotation of the motor by hall signal, and adjust lock detection ON time (Ton) and lock detection OFF time (Toff) by the internal counter. These time (Ton, Toff) are showed below.

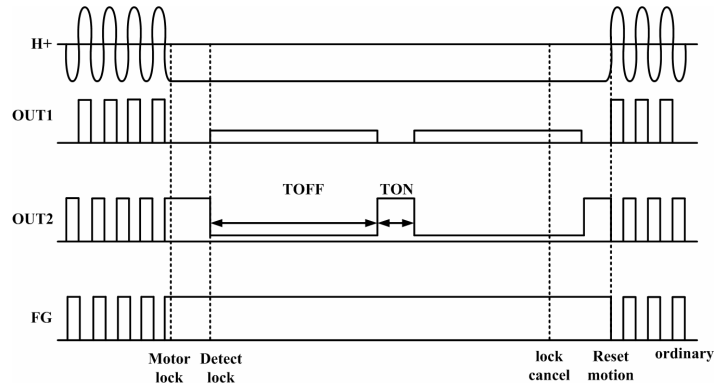

Figure 7. Lock detect and auto restart motion

*Motor does not restart while lock detection off time.

Output current

Less than 4.0V, Iomax is decreased as shown if Fig 8. Please use it not to be over Pd.

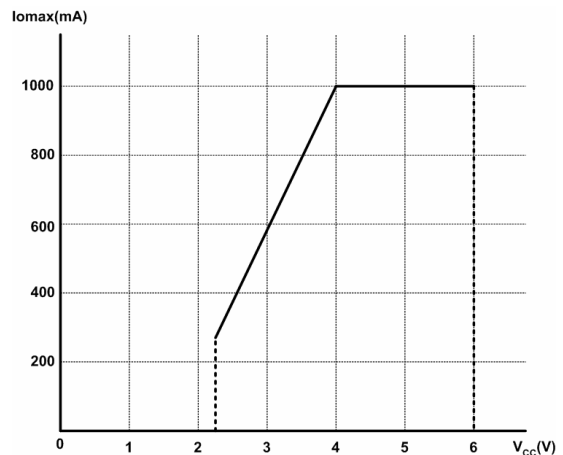
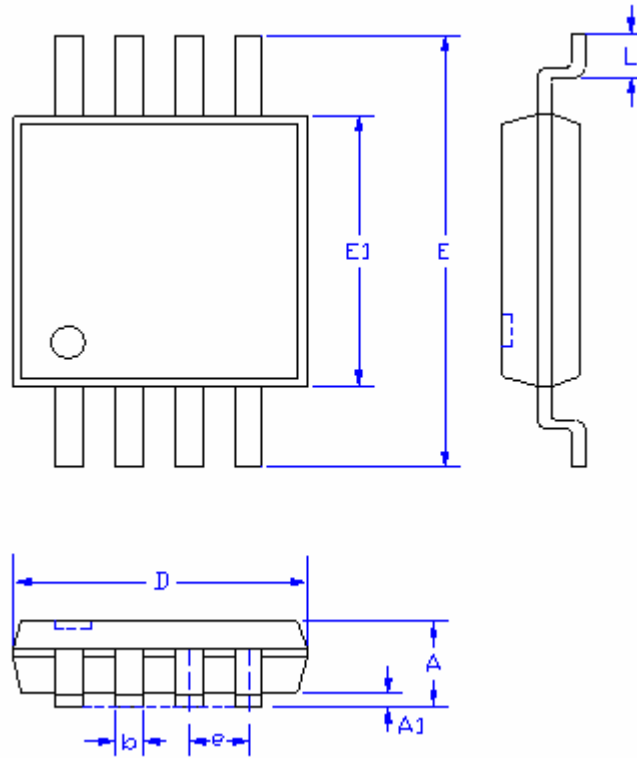

Figure 8. Iomax

Packaging Information

MSOP-8



SYMBOLS	MILLIMETERS		INCHES	
	MIN.	MAX.	MIN.	MAX.
A	-	1.10	-	0.043
A1	0.00	0.15	0.000	0.006
D	3.00		0.118	
E1	3.00		0.118	
E	4.70	5.10	0.185	0.201
L	0.40	0.80	0.016	0.031
b	0.22	0.38	0.008	0.015
e	0.65		0.026	