

# 2W Stereo Audio Power Amplifier

## DESCRIPTION

The EUA4992 is a dual bridge-connected audio power amplifier designed for portable communication device applications such as mobile phone applications. The EUA4992 is capable of delivering 1.3W of continuous average power to an 8Ω BTL and with less than 1% distortion (THD+N) from a 5.0V power supply, and 540mW to an 8Ω BTL load from a 3.3V power supply.

The EUA4992 provides high quality audio while requiring few external components and minimal power consumption. It features a low-power shutdown mode, which is achieved by driving the SHUTDOWN pin with logic low.

The EUA4992 contains circuitry to prevent from "pop and click" noise that would otherwise occur during turn-on and turn-off transitions.

For maximum flexibility, the EUA4992 provides an externally controlled gain (with resistors), as well as an externally controlled turn-on and turn-off times (with the bypass capacitor).

The EUA4992 is available in a 3mm×3mm TQFN package.

## FEATURES

- Output Power at 1% THD+N,  $V_{DD}=5V$ 
  - 2W/CH (typ) into a 4Ω Load
  - 1.3W/CH (typ) into a 8Ω Load
- Output Power at 1% THD+N,  $V_{DD}=3.3V$ 
  - 0.84W/CH (typ) into a 4Ω Load
  - 0.54W/CH (typ) into a 8Ω Load
- Shutdown Current 0.04μA (typ)
- Supply Voltage Range 2.5V to 5.5V
- Suppress "click and pop"
- Thermal Shutdown Protection Circuitry
- Micro Power Shutdown Mode
- TQFN-16 (3mm×3mm) Package
- RoHS compliant and 100% lead(Pb)-free

## APPLICATIONS

- Cell phones, PDA, MP4,PMP
- Portable and Desktop Computers
- Desktops audio System
- Multimedia Monitors

## Typical Application Circuit

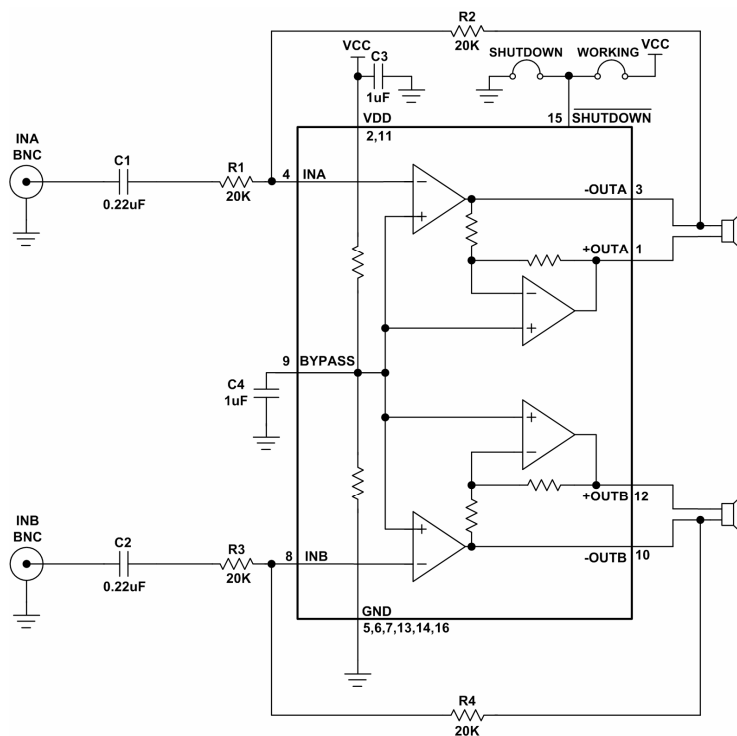

Figure1.

Pin Configurations

Package Type	Pin Configurations
TQFN-16	

Pin Description

NAME	PIN	I/O	DESCRIPTION
INA	4	I	Left Channel Input
INB	8	I	Right Channel Input
-OUTA	3	O	Left Channel -Output
+OUTA	1	O	Left Channel +Output
-OUTB	10	O	Right Channel -Output
+OUTB	12	O	Right Channel +Output
VDD	2,11		Supply Voltage
$\overline{\text{SHUTDOWN}}$	15	I	Shutdown control, hold low for shutdown mode
BYPASS	9		Bypass capacitor which provides the common mode voltage
GND	5,6,7,13,14,16		GND

**Ordering Information**

Order Number	Package Type	Marking	Operating Temperature range
EUA4992JIR1	TQFN-16	xxxxx 4992	-40 °C to 85°C

EUA4992

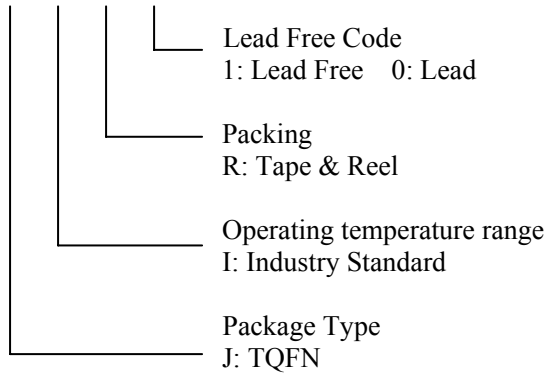

**Absolute Maximum Ratings**

Supply voltage	-----	6V
Input voltage	-----	-0.3 V to $V_{DD} + 0.3V$
Storage temperature rang, $T_{stg}$	-----	-65°C to 150°C
Junction Temperature	-----	150°C

**Recommended Operating Conditions**

	Min	Max	Unit
Supply voltage (from AC input), $V_{CC}$	2.5	5.5	V
Operating junction temperature range, $T_J$	-40	125	°C

**Electrical Characteristics (5V)**

The following specifications apply for  $V_{DD}=5V$  unless otherwise noted. Limits apply for  $T_A=25^\circ C$ .

Symbol	Parameter	Conditions	EUA4992			Unit
			Min	Typ	Max.	
$V_{DD}$	Supply Voltage		2.5		5.5	V
$I_{DD}$	Quiescent Power Supply Current	$V_{IN}=0V, I_O=0A$		6	14	mA
$I_{SD}$	Shutdown Current	GND applied to the shutdown pin		1	3	$\mu A$
$V_{IH}$	Shutdown Input Voltage High		1			V
$V_{IL}$	Shutdown Input Voltage Low				0.4	V
$T_{WU}$	Turn on time	1 $\mu F$ bypass cap (C4)		100		ms
$V_{OS}$	Output Offset Voltage	$V_{IN}=0V$		5	25	mV
$P_O$	Output Power	THD+N=1%, f=1KHz $R_L=4\Omega$		2		W
		THD+N=1%, f=1KHz $R_L=8\Omega$		1.3		W
THD+N	Total Harmonic Distortion + Noise	1KHz, $A_{vd}=2$ $R_L=8\Omega, P_o=1W$		0.08		%
PSRR	Power Supply Rejection Ratio	Input grounded 217Hz $V_{ripple}=200m$ Vp-p C4=1 $\mu F$ , $R_L=8\Omega$		51		dB
		Input grounded 1KHz $V_{ripple}=200m$ Vp-p C4=1 $\mu F$ , $R_L=8\Omega$		60		
Xtalk	Channel separation	f=1KHz, C4=1 $\mu F$		65		dB
$V_{NO}$	Output noise voltage	1KHz		11		$\mu V_{rms}$

**Electrical Characteristics (3.3V)**

The following specifications apply for  $V_{DD}=3.3V$  unless otherwise noted. Limits apply for  $T_A=25^\circ C$ .

Symbol	Parameter	Conditions	EUA4992			Unit
			Min	Typ	Max.	
$I_{DD}$	Quiescent Power Supply Current	$V_{IN}=0V, I_O=0A$		4.1		mA
$I_{SD}$	Shutdown Current	GND applied to the shutdown pin		0.02		$\mu A$
$V_{IH}$	Shutdown Input Voltage High		1			V
$V_{IL}$	Shutdown Input Voltage Low				0.4	V
$T_{WU}$	Turn on time	1 $\mu F$ bypass cap (C4)		100		ms
$V_{OS}$	Output Offset Voltage	$V_{IN}=0V$		2.5		mV
$P_O$	Output Power	THD+N=1%, f=1KHz $R_L=4\Omega$		0.84		W
		THD+N=1%, f=1KHz $R_L=8\Omega$		0.54		W
THD+N	Total Harmonic Distortion + Noise	1KHz, Avd=2 $R_L=8\Omega, P_o=0.45W$		0.08		%
PSRR	Power Supply Rejection Ratio	Input grounded 217Hz Vripple=200m Vp-p C4=1 $\mu F$ , $R_L=8\Omega$		52		dB
		Input grounded 1KHz Vripple=200m Vp-p C4=1 $\mu F$ , $R_L=8\Omega$		60		
Xtalk	Channel separation	f=1KHz, C4=1 $\mu F$		60		dB
$V_{NO}$	Output noise voltage	1KHz		10.15		$\mu V_{rms}$

Packaging Information

TQFN-16

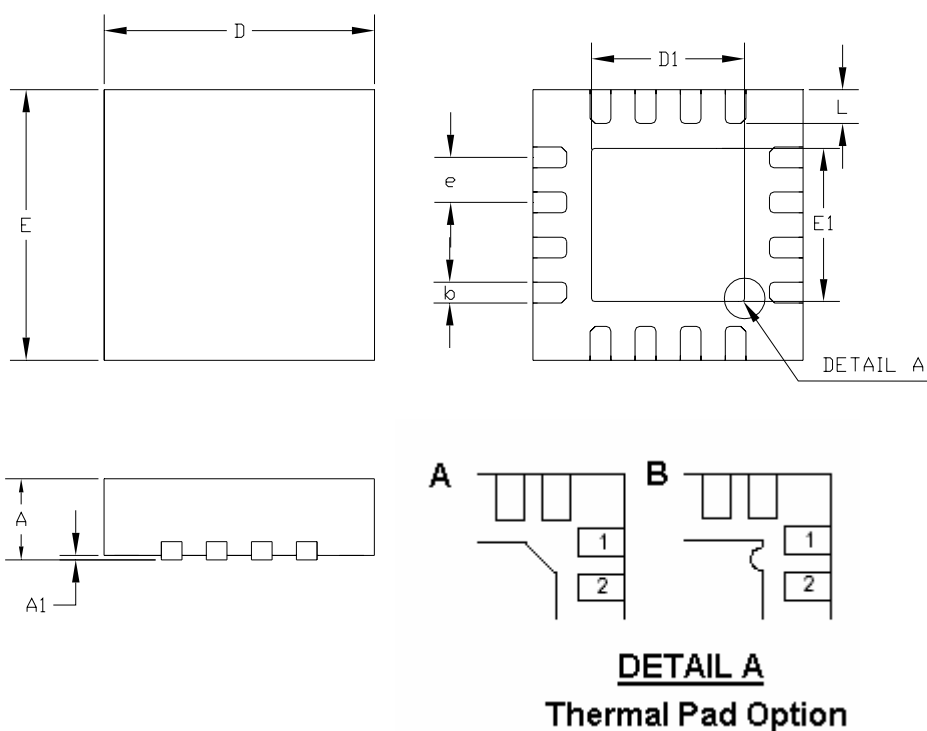

SYMBOLS	MILLIMETERS		INCHES	
	MIN.	MAX.	MIN.	MAX.
A	0.70	0.80	0.028	0.031
A1	0.00	0.05	0.000	0.002
b	0.18	0.30	0.007	0.012
E	2.90	3.10	0.114	0.122
D	2.90	3.10	0.114	0.122
D1	1.70		0.067	
E1	1.70		0.067	
e	0.50		0.020	
L	0.30	0.50	0.012	0.020