



Am7996EVAL-HW

Ethernet/Cheapernet Transceiver Evaluation Kit

DISTINCTIVE CHARACTERISTICS

- Connects the standard AUI port interface to 10BASE-2 (Cheapernet) connector.
- Jumper selectable Signal Quality Error (SQE) test allows evaluation in both node and repeater applications.
- Self contained board facilitates rapid evaluation of the AUI -to-coax system block, and demonstrates optimal analog design criteria.

GENERAL DESCRIPTION

The Am7996EVAL-HW board is a self contained module that implements all the functions of a Medium Attachment Unit (MAU) for IEEE 802.3 10BASE-2 (Cheapernet). This 3"x3" board can be used to connect any AUI port interface to the 'thin' coaxial cable used in Cheapernet networks. This system permits the network designer to monitor signals on the card to increase his

understanding of IEEE 802.3 standards and conventions. A jumper selectable SQE test enable/disable lets the board function in both user node or network repeater applications. In addition, optimal PC board layout is employed. The Am7996EVAL-HW kit comes complete with schematics, application notes, and coaxial cable connection hardware.

BLOCK DIAGRAM

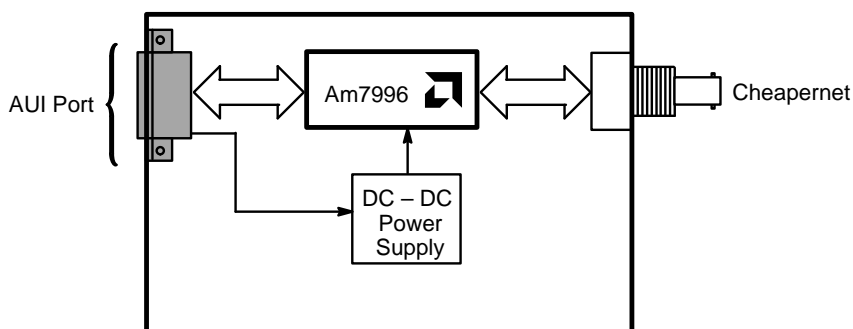

JUMPER SETTINGS

The jumper settings specify the type of collision detect that is used.

Transmit collision detect: connect 1 & 3

Receive collision detect: connect 1 & 2
3 & 4

