

## Smart Com Radio Transceiver IC

WP-RF-RF600T

### General

The RF600T provides a simple interface between TTL level asynchronous serial data sources and standard RF modules (Transceiver, Transmitter or Receiver) with minimal interface required.

The RF600T performs all the necessary data manipulation and encryption required by the Radio module to achieve a reliable radio link whilst providing a simple data interface to the users controller.

The device has been designed to obtain the maximum range from the Radio medium using automatic data packet generation with 'Manchester' encoding and CRC based error checking. In addition, in addressed mode, automatic retries ensure that the host is informed of successful or failed data packet delivery. The RF600T uses control lines to handle the flow of data to and from the host, and incorporates a 190 byte data buffer.

### Features

- Enables Easy Radio Communications
- Connects directly to RF Module
- Simple CMOS/TTL Data Interface
- Performs all Data Encryption for Reliable Data Comms.
- Addressed Mode With Acknowledge
- Broadcast Mode
- Automatic Retry
- Achieves Maximum Range From RF Modules
- Optional host Flow Control
- Two Telemetry I/O Lines (addressed mode only)
- Compatible With Most RF Modules

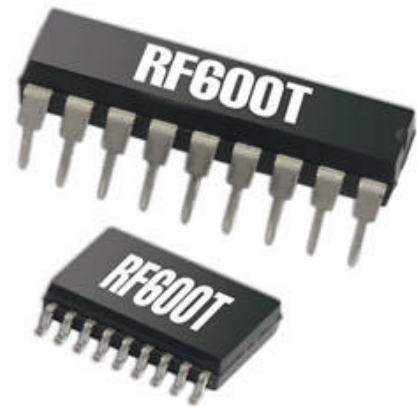

### Typical Applications

- Wireless RS232
- Cable Replacement
- Alarm Systems
- Communications Systems
- Local Area Networking

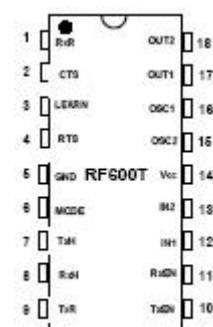

### Hardware Features

- 3.0 – 5.5V Operation. (2.0 – 5.5V optional)
- 190 Byte data Buffer
- 'Manchester' Modulation
- CRC Error Checking
- 18 pin DIP/SOIC Package
- 2 Digital Telemetry Lines (addressed mode only)
- Asynchronous Serial Host Interface

## Pin Description

Pin Number	Name	Type	Description
1	RxR	In	Received data from RF module
2	CTS LOOP	Out In	Dual Function: 1. Clear to send data (to host) when low. 2. Enables loopback mode when low.
3	LEARN	In/Out	In addressed mode: Used to initiate 'address learn' and erase functions. Drives indicator LED.
4	RTS	In	Request to send data (from host) when low.
5	GND	In	Connect to 0 volts.
6	MODE	In	Device mode, addressed when high, broadcast when low.
7	TxH	In	Serial data from the host, to be sent on the RF path.
8	RxH	Out	Serial data from the RF path to be sent to the host.
9	TxR HBAUD	Out In	Dual Function: 1. Transmit data to the RF module. 2. Host baud rate select. See notes below.
10	TXEN RFBAUD	Out In	Dual Function: 1. Transmit enable (low) for the RF module. 2. RF baud rate select. See notes below.
11	RXEN	Out	Receive enable (low) for the RF module.
12	IN1	In	Telemetry logic input #1. (addressed mode only)
13	IN2	In	Telemetry logic input #2. (addressed mode only)
14	Vcc	In	Positive supply voltage connection.
15	OSC2	Out	Connect to 4MHz, 3 terminal resonator.
16	OSC1	In	Connect to 4MHz, 3 terminal resonator.
17	OUT1	Out	Telemetry logic output #1. (addressed mode only)
18	OUT2	Out	Telemetry logic output #2. (addressed mode only)

## Ordering

Part No.	Description
WP-RF-RF600T	Transceiver IC PDIP Package 18pin PDIP
WP-RF-RF600T-SO	Transceiver IC SMT Package 18pin SO
WP-RF-RF600T-EVAL	Evaluation Kit for Smart Radio Modules



## Operating Modes

The device is capable of operation in one of two modes, either broadcast or addressed. The following description describes the features of these mode and assumes two identical system nodes 'A' and 'B' each consisting of an RF600T and its associated radio transceiver module.

The RF600T must be configured before power up for either the broadcast or addressed mode of operation by means of the MODE pin (6). Note that for security, broadcast nodes will not receive data from addressed nodes.

### Broadcast mode

This mode allows a host generated data block from node 'A' to be transmitted and received by any number of other nodes. This data is received and verified (for correct Manchester coding and CRC) by the other nodes before being output to their host devices. Alternately, in the same way the other nodes can send data to node 'A'. Note that although any node can initiate a transfer, only one direction of transfer can be active at a given time.

Correct reception of a data packet is not acknowledged and the host nodes have the responsibility of ensuring that data transfers occur as required by operating some form of message protocol over the half duplex data link.

### Addressed mode

This mode allows a host generated data block from node 'A' to be transmitted and for the data frame to be addressed to one other network node – in this case we assume node 'B'. When the data is received by node 'B' it is verified for correct Manchester coding, CRC and for address match and then an acknowledge message is transmitted back to node 'A'. Node 'A' then outputs a confirmation to the host in the form of the ASCII character 'C' (Confirmed). Note that confirmation is given when the data block is stored in the buffer of node 'B' and not when it has been delivered to the host at node 'B'.

All message transfers are tagged with the addresses of both the origin and destination, thus ensuring secure data transfer at all times. Either node 'A' or node 'B' can initiate a transfer but only one direction of transfer can be active at a given time. In the event that the originating node does not get confirmation of receipt of the data packet, the software re-tries the transfer five times after which node 'A' will output an error message to the host in the form of the ASCII character 'F' (Failed).

Correct reception (or otherwise) of a data packet is thus acknowledged and the host devices are relieved of most of the workload of ensuring that data transfers occur as required.

## System Operation – Broadcast Mode

If operation in the broadcast mode is required then on power up the MODE pin should be pulled low. If however a device has been used in the point to point addressed mode or if its status is unknown then status erase must be carried out using the following procedure. With the unit in addressed mode (power up with MODE low) the LEARN pin is grounded for a period of 5 seconds and is then allowed to float. The status LED then flashes slowly for 3 seconds to indicate that the device is erased.

## System Operation – Addressed Mode

Each RF600T is programmed at manufacture with a 24 bit serial number which uniquely identifies the device. In an addressed point to point system, these serial numbers are used as the device address for the nodes in the system and non-volatile eeprom memory in the device stores the address of the 'other' node in the system.

If operation in the addressed mode is required then the following procedure has to be followed to allow the two nodes in the system to operate together.

The two nodes, 'A' and 'B' are placed within radio range of one another are powered up with the MODE pin held high.

The LEARN pin on one device – say 'B' is briefly taken low, placing the node into learn mode. The LEARN/ERASE status LED on 'B' comes on and remains on for 20 seconds. If within this period, no 'learn' data packet is received (see below) then the LED will be extinguished and the device will operate normally.

At node 'A', the LEARN pin is briefly taken low. The LEARN/ERASE status LED will then come on and node 'A' will transmit its address.

Node 'B' will receive and store the address of 'A'.

Node 'B' sends back to node 'A' both its address and that of node 'A'.

Node 'A' receives and stores the address of 'B' and confirms to 'B' that it has received the information.

Both node 'A' and 'B' LED's flash their status LED's rapidly for 3 seconds to show that they have learned each others addresses.

**Note:** Other nodes which may be active will ignore this transfer since they have not been placed into learn mode.

If notification of correct reception (or otherwise) of data packets is required but it is not possible or desirable to carry out the learn process then a modified addressed mode of operation may be implemented. In this mode, both nodes have their eeprom memory erased using the erase process, thus placing null serial numbers (\$000000) for the 'other' node into both device eeproms. If the devices are now employed in addressed mode (power up with MODE pin high) they will operate as if they had learned one another's identity using the normal learn process. Note that in this mode, only two device may be employed within range of one another since data transfer is effectively carried out as a broadcast to all nodes with a null address.

### Dual Pin Functions

As shown in the pin function list above, a number of output pins have dual usage. During power up they are briefly configured as inputs to allow the selection of system options as shown below. Note that any load connected to these pins must not bias the RF600T pin such that the option setting network is significantly disturbed.

In order to configure these pins it is recommended that they are connected as shown.

1. Tie the relevant pin to Vcc or GND via a 100K resistor. This is useful if the option is permanently unselected.
2. Tie to Vcc or GND via a 100K resistor and also add a jumper link and 2.2K resistor to the other rail. This allows the user to select the function of the pin by insertion/removal of the link.

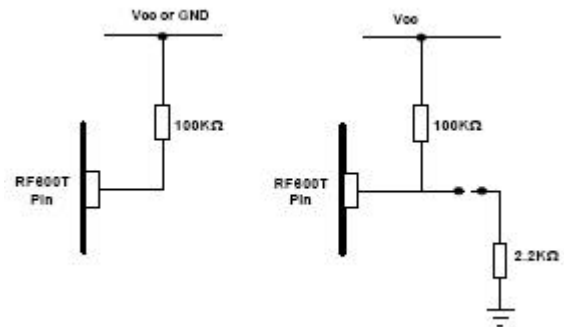

Number	Name	Type	Description
3	LOOP	In	Function during power up: Sets RF600T into 'Loop back' Mode (see below) Disabled if connected to Vcc as shown above. Enabled if connected to GND as shown above.
	CTS	Out	Function after power on: Clear To Send control line to host (when low).
9	HBAUD	In	Function during power up: Host Baud rate Select. 9600baud if connected to Vcc as shown above. 19200baud if connected to GND as shown above.
	TxR	Out	Function after power on: Transmit data to radio module..
10	RFBAUD	In	Function during power up: Controls the baud rate for the RF link. 400uS if connected to Vcc as shown above. 200uS if connected to GND as shown above.
	TXEN	Out	Function after power on: Transmit enable (low) to radio module.

### Learn pin (addressed mode only)

The learn pin is used both to sense the learn/erase switch and also to drive the indicator LED and should be connected as shown in the application circuit. The switch, which should be of the normally open type, should be connected from the learn pin to ground. The LED and its series current limiting resistor should this data sheet) is not exceeded.

### Data Buffering

The device contains a 190 byte data buffer which is used to either buffer host data prior to transmission over the radio link or alternately to buffer data received over the radio link before it is transmitted to the host. Since this is a shared buffer the device can only operate in a half duplex manner - that is at a given time data can either be received from the host and then transmitted over the radio link or data can be received over the radio link and sent to the host but these functions cannot occur at the same time. Once a character has been received from the host or once the start of a radio data packet has been sensed the device will lock out the 'other' function until the first one has been completed.



## Host Interface

The interface to the host device consists of the following signal and control lines:

- TxH  
Serial data from the host which is to be transmitted over the RF link. Idle mark '1'.
- RxH  
Serial data for the host which has been received over the RF link. Idle mark '1'.
- CTS  
Handshake line to the host. When '0' tells the host that it is Clear To Send data to the RF600T for transmission over the RF link.
- RTS  
Handshake line from the host. When '0' tells the RF600T that the host is making a Request To Send data to the host.

## Host Communications

All host communications are carried out using the following asynchronous serial format.

8 data bits.

1 stop bit.

No parity.

The host baud rate is selected using the HBAUD option as described above.

## Host Data Flow Control

Serial data from the host which is to be sent over the radio link is input at TTL level on the TxH pin. When the device is ready to receive data, the CTS line from the device will be low and up to 190 data bytes will be accepted and stored in the internal data buffer. When the buffer becomes full the CTS line will be taken high and the host must then stop transmitting. In order to allow for host UART's which have an output FIFO buffer, a further 4 characters will be accepted after the CTS line has been asserted. In the event that the flow of data characters is not contiguous and an idle period of 20 ms occurs in the data stream then the CTS line will be asserted high to signify that the host should stop sending further data. In this case the current buffer contents will make up the next data packet to be sent over the radio link.

Serial data which has been received over the radio link will be checked for correct Manchester coding and CRC checksum (and address match if in addressed mode) before this data is transmitted at TTL level on the RxH pin. Data flow to the host is controlled by the RTS line from the host. When this line is low, data in the buffer will be transmitted to the host. When the RTS line is taken high then data flow will be inhibited and until the buffer is empty the device will not be able to perform any other operations.

## Packet Size and Timing

The following information is provided to aid in timing calculations for the RF data transmission.

Element	Size (bits)	Modes Present
Run-In / Pre-amble	76	Both
Sync Pattern	4	Both
Start Bit	1	Both
Command Byte	8	Both
Source Address	32	Addressed only
Destination Address	32	Addressed only
Data Bytes	xxx	Both
Checksum	8	Both

Addressed mode packet overhead:

$$PO_a = 76+4+1+8+32+32+8 = 161 \text{ bits}$$

Addressed Transmission time, presuming 200uS element time, no idle period:

$$TT_a = 200\mu\text{S} \times (PO_a + \text{No. Data Bits})$$

Please note this timing is for RF transmission only the RS232 communications timing is not included.

## Radio Module Interface

The interface to the radio module(s) consists of the following signal and control lines:

- TxR  
Serial data output from the RF600T to the radio module.
- RxR  
Serial Data input to the RF600T from the radio module.
- TXEN  
When active low the RF Transmitter is enabled
- RXEN  
When active low the RF Receiver is enabled

## Radio Module Communications

All data communications between the radio modules are carried out using an R. F. Solutions proprietary data protocol with Manchester coding. This protocol includes a pre-amble and synchronisation header followed by address and control bytes, data and a CRC check. Element timing is selectable at either 400 us or 200 us using the HBAUD option as described above.

## Radio Module Control

The RXEN and TXEN control lines are used to enable or disable the receiver and transmitter modules – or in the case of a transceiver module, to control the direction of operation. The logic of these outputs is such that when the RF600T wishes to transmit, it will take the RXEN line high and the TXEN line low. When the RF600T wishes to receive, it will take the RXEN line low and the TXEN line high.



## Digital Telemetry Lines (addressed mode only)

In addressed mode, two input pins have their state monitored at all times and when either changes state the new states will be transmitted and applied to the outputs at the other nodes. If system is idle this information will be transmitted as part of a 'dummy' data packet, which contains no data. If the system is transferring data then the telemetry information is added in the command byte of the next transmitted data packet.

Some care is required in using the logic pins as shown in the following notes.

1. The acknowledge and retry functions are not applied to these transmissions
2. If host data is being transmitted to the device when the logic input pins change state then the new state will not be transmitted until the current host data packet is sent. (The data packet is sent according to the flow control rules)

## Loop Mode

Loop mode is provided to allow testing of the performance of a system and allows node 'A' to transmit a data packet which will be looped back by node 'B' and received by node 'A'. The mode settings of the nodes are ignored in the loop mode and the transfer is carried out in broadcast mode. The mode must only be selected when there are just two nodes in a network.

If we assume that we wish to send a host data packet from node 'A' to node 'B' and have the packet returned such that host 'A' receives back its data packet then the LOOP link in node 'A' should be made before that unit is powered up. This unit will now only operate in the loop mode until it is powered down, the loop link removed and then powered up again.

Note that the learn function will not operate when the system is configured for loop mode.

## System Testing

Testing of a prototype system can best be carried out using two PC's running HyperTerminal with the properties set as follows. (options not listed can be left in default state)

Connect to: direct to COM1 or COM2

Configure (port settings):

Baud rate: 9600 or 19200 depending on RF600T setting.

Data bits: 8

Parity: none

Stop bits: 1

Flow control: hardware

Settings:

Emulation: TTY

Note that addressed mode file transfers should be tested using the drop down menu option: 'Transfer – Send Text File' and NOT the 'Transfer – Send File' option since this latter employs modem transfer protocols such as Xmodem and Kermit which will be confused by the 'C' and 'F' responses sent back from the RF600T.



### Application Circuit

The circuit shown below is for a typical RF600T application. A 9 way 'D' connector provides an RS232 termination to the host system and the RXQ1 hybrid contains all of the circuitry required to implement the RF path. In many applications it will be possible to dispense with the option links and hard-wire the options to the desired settings. Note however that the host and RF baud options and loop option must be set using resistors as described above.

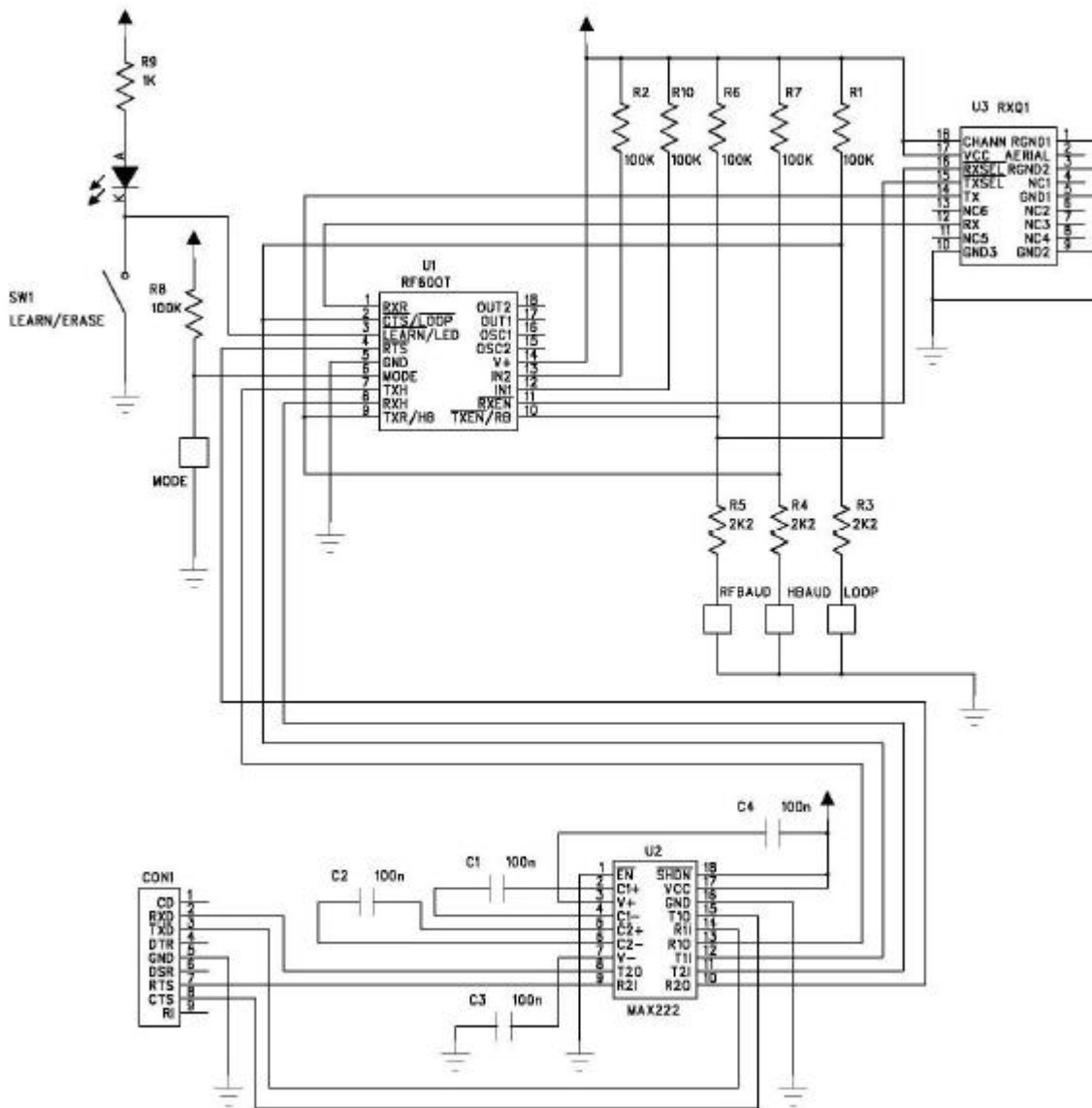

RF600T Application Circuit with RXQ1 Transceiver and RS232 Interface.



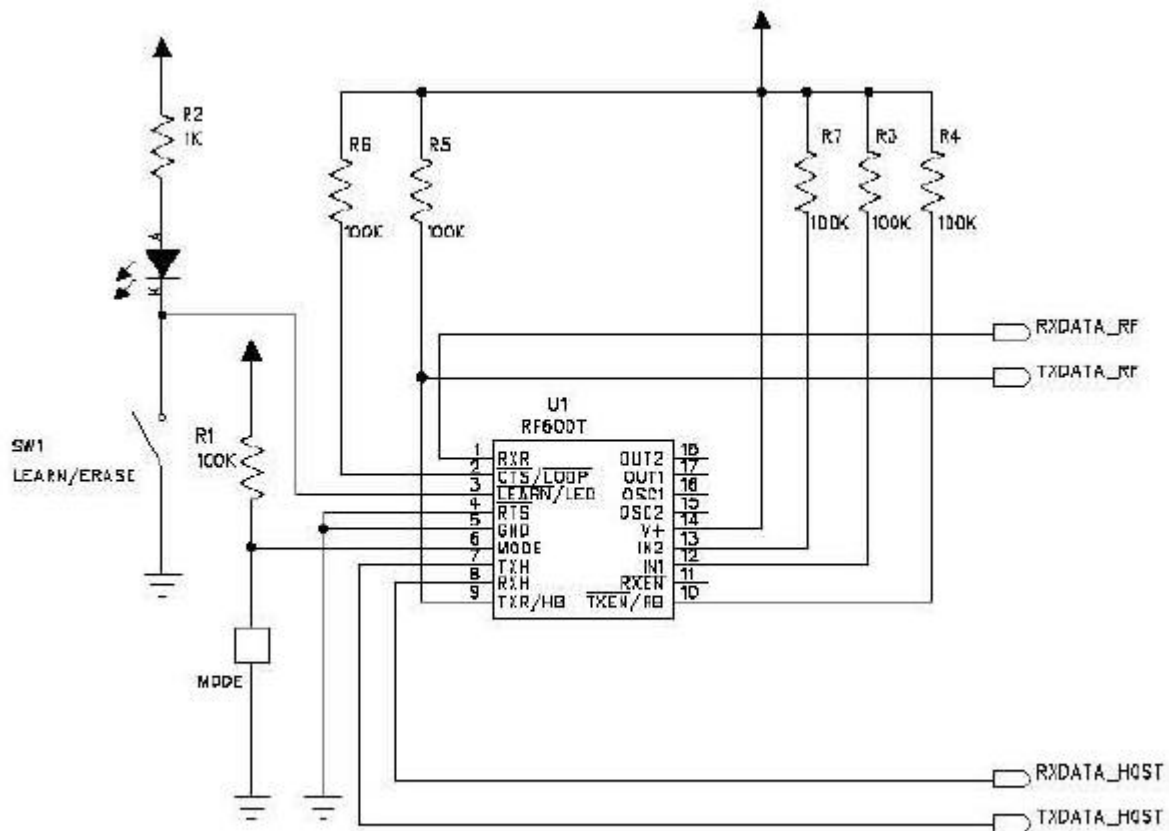

RF600T application circuit – minimum implementation.

This circuit shows the minimum implementation of the RF600T. Two such circuits should be constructed with RXDATA\_RF connected to TXDATA\_RF (that is the RF data paths are crossed over). Data input on the TXDATA\_HOST input of one RF600T will then appear on the RXDATA\_HOST pin of the other RF600T. Note that in this circuit the host data rate is fixed at 9600 bauds and the 'RF' data element time is 400 us. Either broadcast or addressed modes may be used depending on the setting of the option link.

**Smart Radio Evaluation Kit**

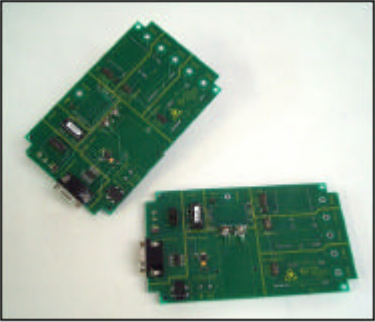
<p>The Smart Radio Evaluation Kit provides a hardware platform to enable fast development of Radio applications. Supplied as a pair of boards, each can accept a variety of RF Modules including transmitters, receivers and transceivers, an RS232 port is incorporated for direct connection to a PC. The boards may be used for a wide range of tasks from simple RS232 data transmission to integrated system development and is the ideal platform for exploring the advantages of using the “Smart Comms” range of ICs and radio modules. This eliminates the need to construct hand-wired prototype boards, which are rarely successful in creating a valid environment for the development of radio systems. (prototyping board also contains large stray capacitance values which has a detrimental effect on the RF connections).</p>	
<ul style="list-style-type: none"> <li>• Hardware Platform for Radio Comms Development</li> <li>• Accepts Various RF Modules</li> <li>• RS232 Interface to PC</li> <li>• Supplied with RF600T Smart Comms Controller</li> <li>• Performs all Data Encryption for Reliable Data Comms.</li> <li>• Two Telemetry I/O Lines (addressed mode only)</li> <li>• Range Testing</li> <li>• Target Environment Testing</li> <li>• Antenna Evaluation</li> </ul>	<p><b>Contents</b></p> <ul style="list-style-type: none"> <li>• Two Eval Boards</li> <li>• Two RF600T Comms Controllers</li> <li>• Circuit diagrams</li> <li>• Two RS232 PC cables</li> </ul> <p>Radio Modules and Antenna available Separately.</p>

**Achieving Optimum Range**

Range is dependant on many factors including

1. RF Power output
2. Receiver sensitivity
3. Antenna efficiency
4. Local environmental conditions and any local Interference
5. Data Type which is being transmitted.

Whilst items 1-4 are dependant on the system hardware design, item ‘5’ is equally important and often overlooked. Given that there is a legal maximum power output which can be transmitted, and a limit on the sensitivity of the receiver (usually constrained by cost), and that the antenna can never achieve 0dB loss (100% efficiency), then the data structure and coding is an important aspect of the design.

The RF600T uses a fully balanced Manchester encoded data protocol designed for optimum use of the radio transmission path. Manchester encoding enables the receiver ‘data slicer’ to maintain efficiency for the duration of the data packet, (unlike many other encoder/decoder systems) which results in reduced bit errors and therefore ensures maximum range.

**Custom Versions**

Customisation of the RF600T is available; please contact our sales department for further information.



## Technical Specifications: Absolute Maximum Ratings

Item	Rating	Units
Supply voltage	-0.3 to 6.9	V
Input voltage	-0.3 to VDD + 0.3	V
Output voltage	-0.3 to VDD+ 0.3	V
Max output current	25	mA
Storage temperature	-55 to +125	°C (Note)
Lead soldering temp	300	°C (Note)
ESD rating	4000	V

Note: Stresses above those listed under "Absolute Maximum Ratings" may cause permanent damage to the device.

Electrical Characteristics	Min	Typical	Max	Unit
Operating current (average) Vdd = 2 - 3V Vdd = 3 - 6.6V		0.3 0.7	1.2 1.6	mA
High level input voltage	0.55V <sub>DD</sub>		V <sub>DD</sub> +0.3	V
Low level input voltage	0.3		0.15V <sub>DD</sub>	V
High level output voltage	0.7V <sub>DD</sub>			V
Low level output voltage			0.08V <sub>DD</sub>	V
Output Pin Current rating		-	25	mA
LED sink current		5.0	25	mA

**Packaging Diagrams and Parameters**

18-Lead Plastic Dual In-line (P) – 300 mil (PDIP)

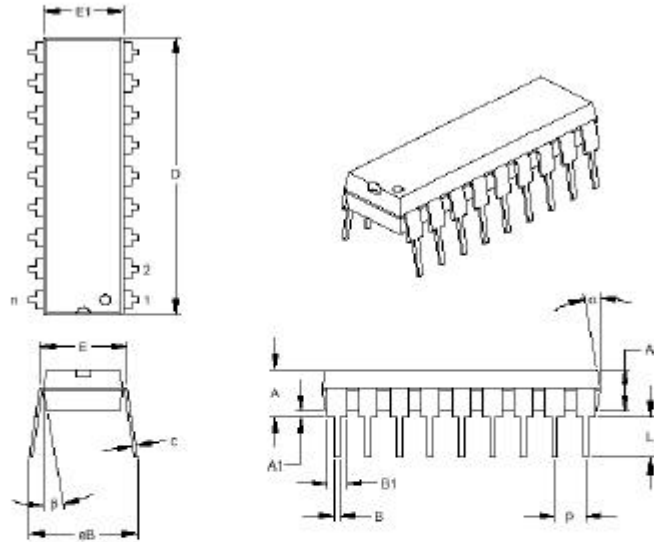

Dimension	Units	INCHES*			MILLIMETERS		
		MIN	NOM	MAX	MIN	NOM	MAX
Number of Pins	n		18			18	
Pitch	p		.100			2.54	
Top to Seating Plane	A	.140	.155	.170	3.58	3.94	4.32
Molded Package Thickness	A2	.115	.130	.145	2.92	3.30	3.68
Base to Seating Plane	A1	.015			0.38		
Shoulder to Shoulder Width	E	.300	.313	.325	7.62	7.94	8.26
Molded Package Width	E1	.240	.250	.260	6.10	6.35	6.60
Overall Length	D	.890	.898	.905	22.61	22.69	22.99
Tip to Seating Plane	L	.125	.130	.135	3.18	3.30	3.43
Lead Thickness	c	.008	.012	.015	0.20	0.29	0.38
Upper Lead Width	B1	.045	.058	.070	1.14	1.46	1.78
Lower Lead Width	B	.014	.018	.022	0.36	0.46	0.56
Overall Row Spacing	eB	.310	.370	.430	7.87	9.40	10.92
Mold Draft Angle Top	α	5	10	15	5	10	15
Mold Draft Angle Bottom	β	5	10	15	5	10	15

\*Controlling Parameter

Notes:

Dimensions D and E1 do not include mold flash or protrusions. Mold flash or protrusions shall not exceed .010" (0.254mm) per side.

JEDEC Equivalent: MS-001

Drawing No. 004-007

Packaging Diagrams and Parameters

18-Lead Plastic Small Outline (SO) – Wide, 300 mil (SOIC)

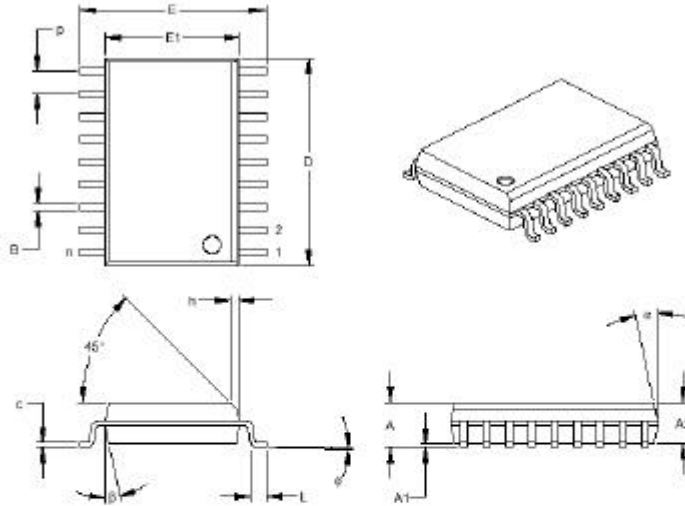

Dimension	Units	INCHES*			MILLIMETERS		
		MIN	NOM	MAX	MIN	NOM	MAX
Number of Pins	n		18			18	
Pitch	p		.050			1.27	
Overall Height	A	.093	.099	.104	2.36	2.50	2.64
Molded Package Thickness	A2	.088	.091	.094	2.24	2.31	2.39
Stanchion	A1	.004	.008	.012	0.10	0.20	0.30
Overall Width	E	.394	.407	.420	10.01	10.34	10.67
Molded Package Width	E1	.391	.395	.399	9.99	10.01	10.13
Overall Length	D	.446	.454	.462	11.33	11.53	11.73
Chamfer Distance	h	.010	.020	.029	0.25	0.50	0.74
Foot Length	L	.016	.033	.050	0.41	0.84	1.27
Foot Angle	φ	0	4	8	0	4	8
Lead Thickness	c	.009	.011	.012	0.23	0.27	0.30
Lead Width	B	.014	.017	.020	0.36	0.42	0.51
Mold Draft Angle Top	α	0	12	15	0	12	15
Mold Draft Angle Bottom	β	0	12	15	0	12	15

\*Controlling Parameter  
 Notes:  
 Dimensions D and E1 do not include mold flash or protrusions. Mold flash or protrusions shall not exceed .010" (0.254mm) per side.  
 JEDEC Equivalent: MS-013  
 Drawing No. CD4-051

