

UTC MC4560 LINEAR INTEGRATED CIRCUIT

DUAL OPERATIONAL AMPLIFIER

DESCRIPTION

The UTC MC4560 integrated circuit is a high-gain, wide-bandwidth, dual operational amplifier capable of driving 20V peak-to-peak into 400 Ω loads. The MC4560 combines many of the features of the MC4558 as well as providing the capability of wider bandwidth, and higher slew rate make the MC4560 ideal for active filters, data and telecommunications, and many instrumentation applications. The availability of the MC4560 in the surface mounted micro-package allows the MC4560 to be used in critical applications requiring very high packing densities.

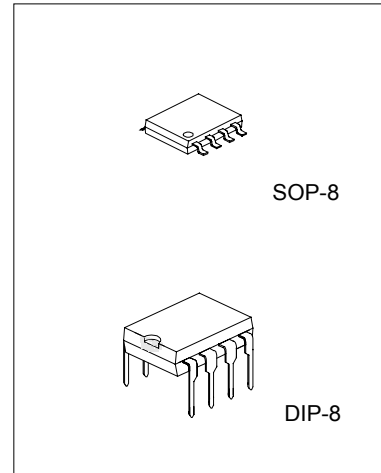

FEATURES

- *Operating Voltage ($\pm 4V \sim \pm 18V$)
- *Wide Gain Bandwidth Product. (10MHz typ.)
- *Slew Rate (4V / μs typ.)
- *Bipolar Technology

PIN CONFIGURATION

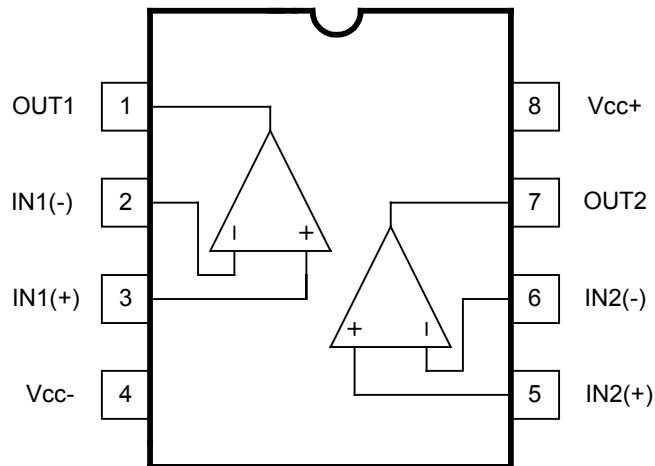

UTC MC4560 LINEAR INTEGRATED CIRCUIT

BLOCK DIAGRAM

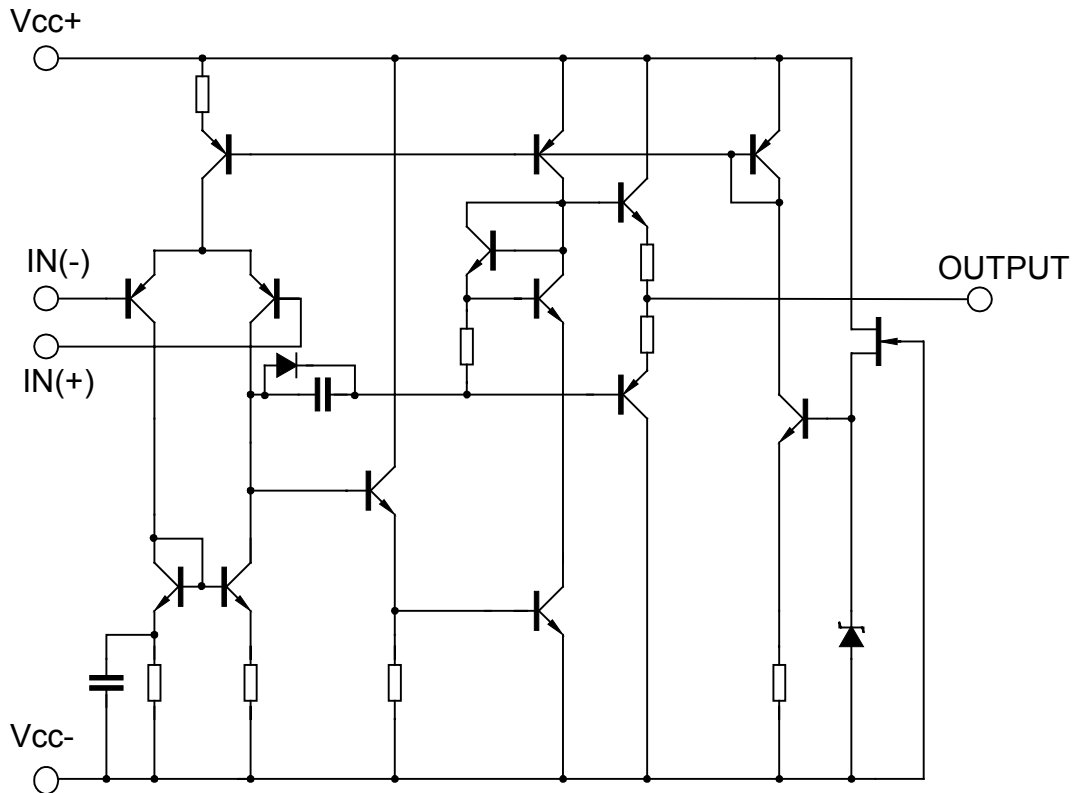

ABSOLUTE MAXIMUM RATINGS (Ta=25°C)

PARAMETER	SYMBOL	RATINGS	UNIT
Supply Voltage	V+/V-	±18	V
Differential Input Voltage	V _{ID}	±30	V
Input Voltage	V _I	±15(note)	V
Power Dissipation	P _D		
DIP-8		500	mW
SOP-8		300	mW
Operating Temperature Range	T _{OPR}	-20 ~ +75	°C
Storage Temperature Range	T _{STG}	-40 ~ +125	°C

Note: For supply voltage less than ±15V, the absolute maximum input voltage is equal to the supply voltage.

UTC MC4560 LINEAR INTEGRATED CIRCUIT

ELECTRICAL CHARACTERISTICS (Ta=25°C, V+/V- = ±15V)

PARAMETER	SYMBOL	TEST CONDUCTION	MIN	TYP	MAX	UNIT
Input offset voltage	V _{IO}	R _s ≤ 10kΩ	-	0.5	6	mV
Input offset current	I _{IO}		-	5	200	nA
Input bias current	I _B		-	40	500	nA
Input Resistance	R _{IN}		0.3	5	-	MΩ
Large Signal Voltage Gain	A _V	R _L ≥ 2kΩ, V _o = ±10V	86	100	-	dB
Maximum Output Voltage 1	V _{OM1}	R _L ≥ 2kΩ	±12	±14	-	V
Maximum Output Voltage 2	V _{OM2}	I _o = 25mA	±10	±11.5	-	V
Input Common Mode Voltage Range	V _{ICM}		±12	±14	-	V
Common Mode Rejection Ratio	CMR	R _s ≤ 10kΩ	70	90	-	dB
Supply Voltage Rejection Ratio	SVR	R _s ≤ 10kΩ	76.5	90	-	dB
Operating Current	I _{CC}		-	4.3	5.7	mA
Slew Rate	SR		-	4	-	V/μs
Gain Bandwidth Product	GB		-	10	-	MHz
Equivalent Input Noise Voltage	V _{NI}	RIAA, R _s = 2kΩ, 30kHz LPF	-	1.2	-	μVrms

UTC MC4560 LINEAR INTEGRATED CIRCUIT

TYPICAL CHARACTERISTICS

OPEN LOOP VOLTAGE GAIN vs. FREQUENCY
($V_{+}/V_{-} = \pm 15V$, $R_L = 2k\Omega$, $T_a = 25^\circ C$)

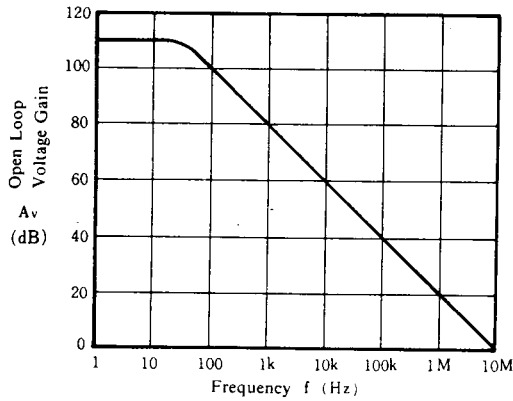

MAXIMUM OUTPUT VOLTAGE SWING vs. FREQUENCY
($V_{+}/V_{-} = \pm 15V$, $T_a = 25^\circ C$)

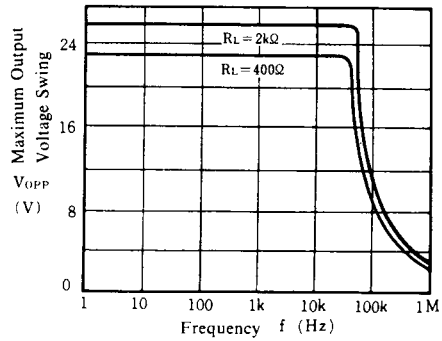

MAXIMUM OUTPUT VOLTAGE SWING vs. LOAD RESISTANCE
($V_{+}/V_{-} = \pm 15V$, $T_a = 25^\circ C$)

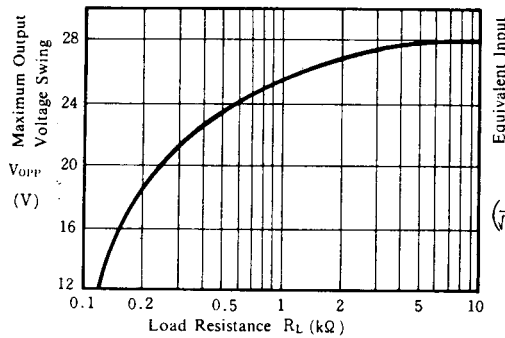

EQUIVALENT INPUT NOISE VOLTAGE vs. FREQUENCY
($V_{+}/V_{-} = \pm 15V$, $R_s = 50\Omega$, $A_v = 60dB$, $T_a = 25^\circ C$)

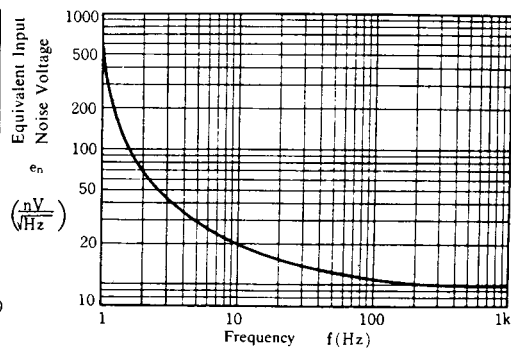

OPERATING CURRENT vs. TEMPERATURE
($V_{+}/V_{-} = \pm 15V$)

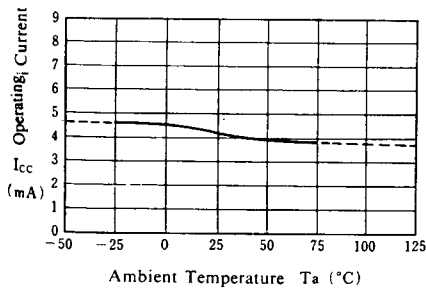

MAXIMUM OUTPUT VOLTAGE SWING vs. TEMPERATURE
($V_{+}/V_{-} = \pm 15V$, $R_L = 2k\Omega$)

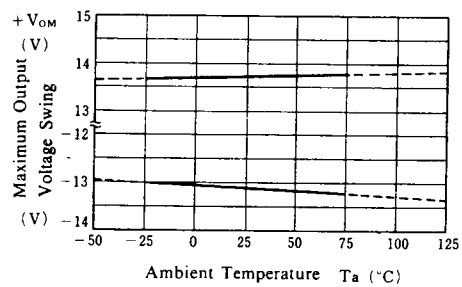

UTC MC4560 LINEAR INTEGRATED CIRCUIT

INPUT OFFSET VOLTAGE vs. TEMPERATURE
($V^+/V^- = \pm 15V$)

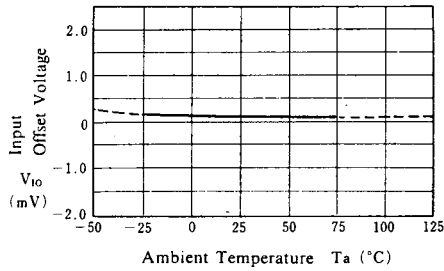

INPUT BIAS CURRENT vs. TEMPERATURE
($V^+/V^- = \pm 15V$)

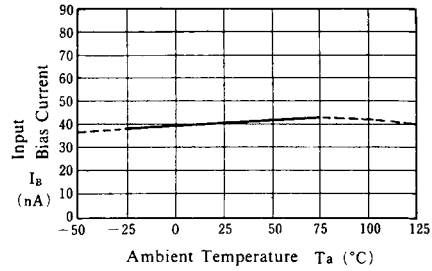

MAXIMUM OUTPUT VOLTAGE SWING vs. SUPPLY VOLTAGE
($R_L = 400\Omega$, $T_a = 25^\circ C$)

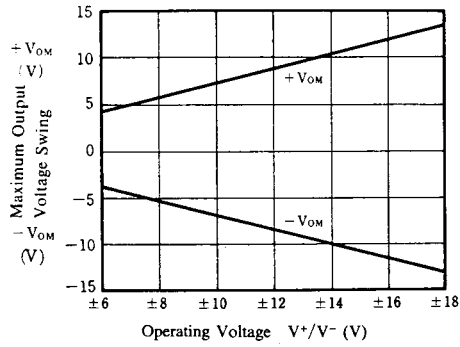

OPERATING CURRENT vs. OPERATING VOLTAGE
($T_a = 25^\circ C$)

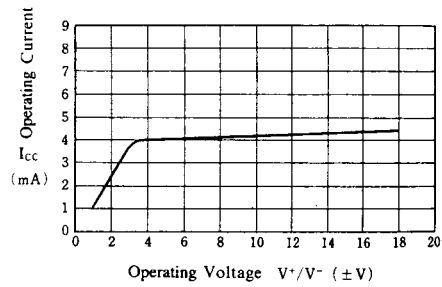

UTC assumes no responsibility for equipment failures that result from using products at values that exceed, even momentarily, rated values (such as maximum ratings, operating condition ranges, or other parameters) listed in products specifications of any and all UTC products described or contained herein. UTC products are not designed for use in life support appliances, devices or systems where malfunction of these products can be reasonably expected to result in personal injury. Reproduction in whole or in part is prohibited without the prior written consent of the copyright owner. The information presented in this document does not form part of any quotation or contract, is believed to be accurate and reliable and may be changed without notice.