



# TS34063

## Dc to Dc Converter Controller

SOP-8



DIP-8

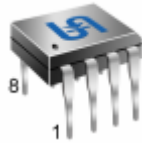

Pin assignment:

1. SC
2. SE
3. CT
4. Gnd
5. Comp.
6. Vcc
7. Ipk
8. Vdriver

**Supply Voltage Range 3 V to 40V**  
**Output Driving Current 1.5A**  
**Oscillator Frequency up to 100KHz**

### General Description

The TS34063 is a monolithic switching regulator and subsystem intended for use as DC to DC converter. It contains an internal temperature compensated reference, comparator, controlled duty cycle oscillator with an active peak current limit circuit, drive and a high current output switch.

The TS34063 is specifically designed to be incorporated in step-up, step-down and voltage inverting converter applications.

The TS34063 is offered in SOP-8 and DIP-8 package.

### Features

- ✧ Power forward control circuit
- ✧ Operating voltage form 3V to 40V
- ✧ Low standby current
- ✧ Current limit adjustable
- ✧ Output switch current up to 1.5A
- ✧ Variable oscillator frequency up to 100KHz (max)
- ✧ Output voltage adjustable

### Pin Descriptions

Name	Description
SC	Switch Collector
SE	Switch Emitter
CT	Timing Capacitor
Gnd	Ground
Comp.	Comparator Inverting Input
Vcc	Vcc Collector
Ipk	Ipk Sense
Vdriver	Driver

### Applications

- ✧ Charger
- ✧ xD-ROM, xDSL product
- ✧ DC to DC converter s

### Ordering Information

Part No.	Operating Temp. (Ambient)	Package
TS34063CD	-20 ~ +85 °C	DIP-8
TS34063CS		SOP-8

### Block Diagram

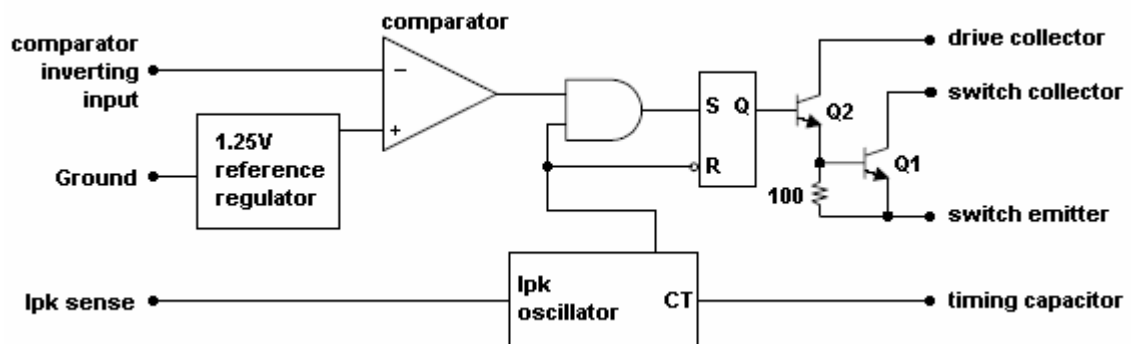



Absolute Maximum Rating						
Supply Voltage	$V_{CC}$	40	V			
Comparator Input Voltage Range	$V_{FB}$	- 0.3 ~ 40	V			
Switch Collector Output Voltage	$V_{C(SW)}$	40	V			
Switch Emitter Voltage	$V_{E(SW)}$	40	V			
Switch Collector to Emitter Voltage	$V_{CE(SW)}$	40	V			
Driver Collector Voltage	$V_C(\text{driver})$	40	V			
Driver Collector Current (note 1)	$I_C(\text{driver})$	100	mA			
Output Switching Current	$I_{SW}$	1.5	A			
Power Dissipation	DIP-8 SOP-8	$P_d$	1.0 0.5	W		
Operating Junction Temperature Range	$T_J$	-0 ~ +125	°C			
Storage Temperature Range	$T_{STG}$	-65 ~ +150	°C			
Note: Maximum package power dissipation limits must be observed						
Electrical Characteristics ( $V_{CC} = 5V$ , $T_a = 25^\circ C$ ; unless otherwise specified.)						
Parameter	Symbol	Test Conditions	Min	Typ	Max	Unit
<b>Oscillator (OSC)</b>						
Frequency	$F_{OSC}$	$C_T = 1nF$ , $V_{pin5} = 0V$	24	33	42	KHz
Charge Current	$I_{CHARGE}$	$V_{CC} = 5V \sim 40V$	--	30	--	uA
Discharge Current	$I_{DISCHARGE}$	$V_{CC} = 5V \sim 40V$	--	200	--	uA
Discharge to Charge current ratio	$I_{DISCHARGE} / I_{CHARGE}$	Pin7 to $V_{CC}$	--	6.5	--	--
Current Limit Sense Voltage	$V_{IPK(SENSE)}$	$I_{DISCHARGE} = I_{CHARGE}$	250	--	350	mV
<b>Output switch (note1)</b>						
Saturation Voltage	$V_{CE(SAT)}$	$I_{SW} = 1A$ , pin1,8 connected)	--	1.0	1.3	V
Saturation Voltage	$V_{CE(SAT)}$	$I_{SW} = 1A$ , $I_d = 50mA$	--	0.45	0.7	V
DC current gain	$H_{FE}$	$I_{SW} = 1A$ , $V_{ce} = 0.5V$	--	75	--	--
Collector off-state current	$I_{C(OFF)}$	$V_{ce} = 40V$	--	0.01	100	uA
<b>Comparator</b>						
Threshold Voltage	$V_{REF}$		1.225	1.25	1.275	V
Line regulation	RegLine	$V_{CC} = 3V \sim 40V$	--	--	6	mV
<b>Total device</b>						
Supply Current	$I_{CC}$	$V_{CC} = 5V \sim 40V$ , $C_T = 1nF$ , pin7= $V_{CC}$ , pin5>> $V_{th}$ , pin2=Gnd, remaining pins open	--	3	5	mA

Note: 1. Low duty cycle pulse techniques are used during test to maintain junction temperature as close to ambient temperature as possible

2. If the output switch is driven into hard saturation (non-Darlington configuration) at low switch currents ( $\leq 300mA$ ) and high driver currents ( $> 30mA$ ), it may take up to 2uS for it to come out of saturation. This condition will shorten the off time at frequencies  $\geq 30KHz$ , and is magnified at high temperature. This condition does not occur with a Darlington configuration, since the output switch cannot saturate. If a non-Darlington configuration is used, the following output drive condition is recommended:

Forced Beta of output switch:  $I_C \text{ output} / (I_C \text{ driver} - 7mA^*) \geq 10$

\* The 100ohm resistor in the emitter of the driver divide requires about 7mA before the output switch conducts.

## Circuit Description

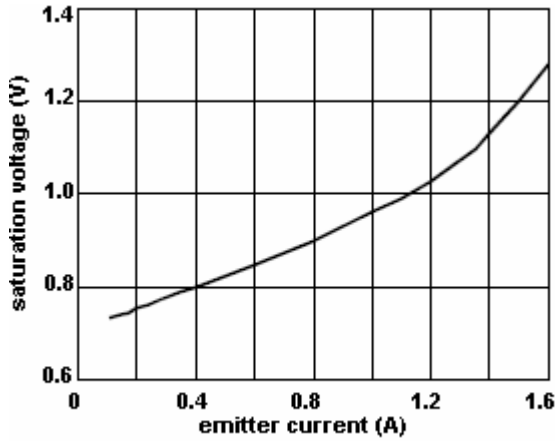

Figure 1. Vce(sat) vs emitter current

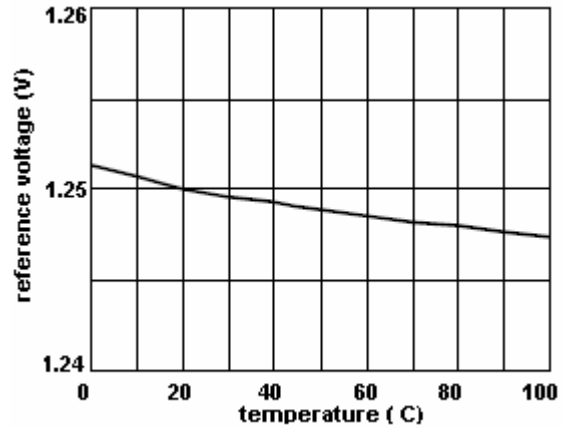

Figure 2. reference voltage vs temp.

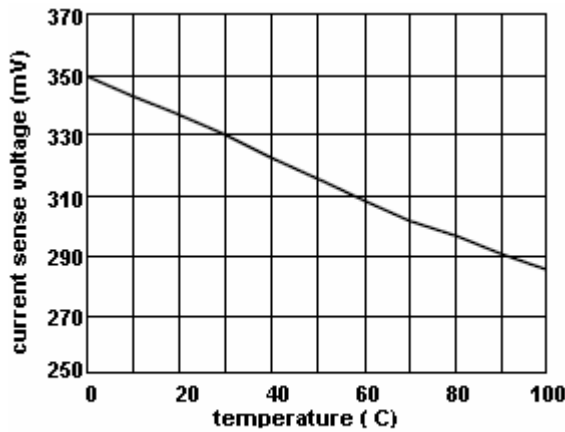

Figure 3. current limit sense voltage vs temperature

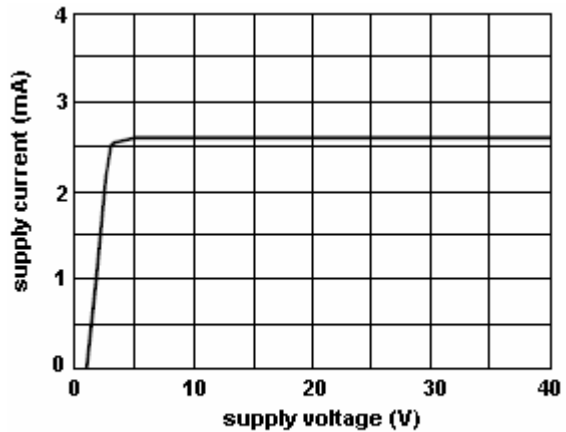

Figure 4. standby supply current vs supply voltage

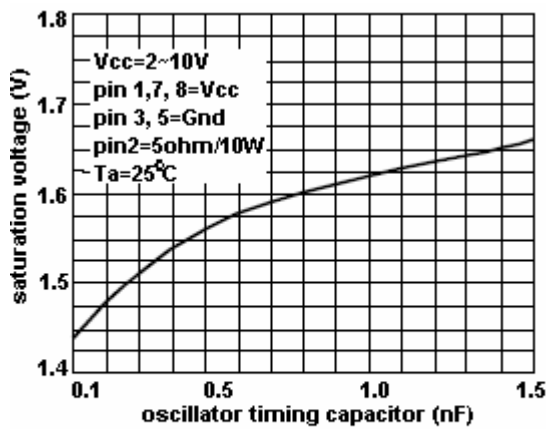

Figure 5. emitter follower configuration output saturation voltage vs emitter current

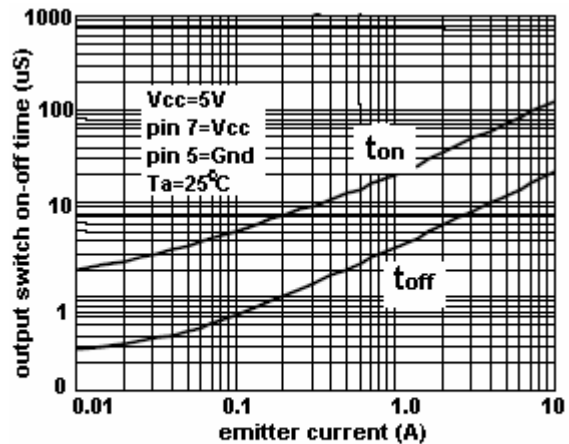

Figure 6. output switch on-off time vs oscillator timing capacitor

## Typical Application Circuit

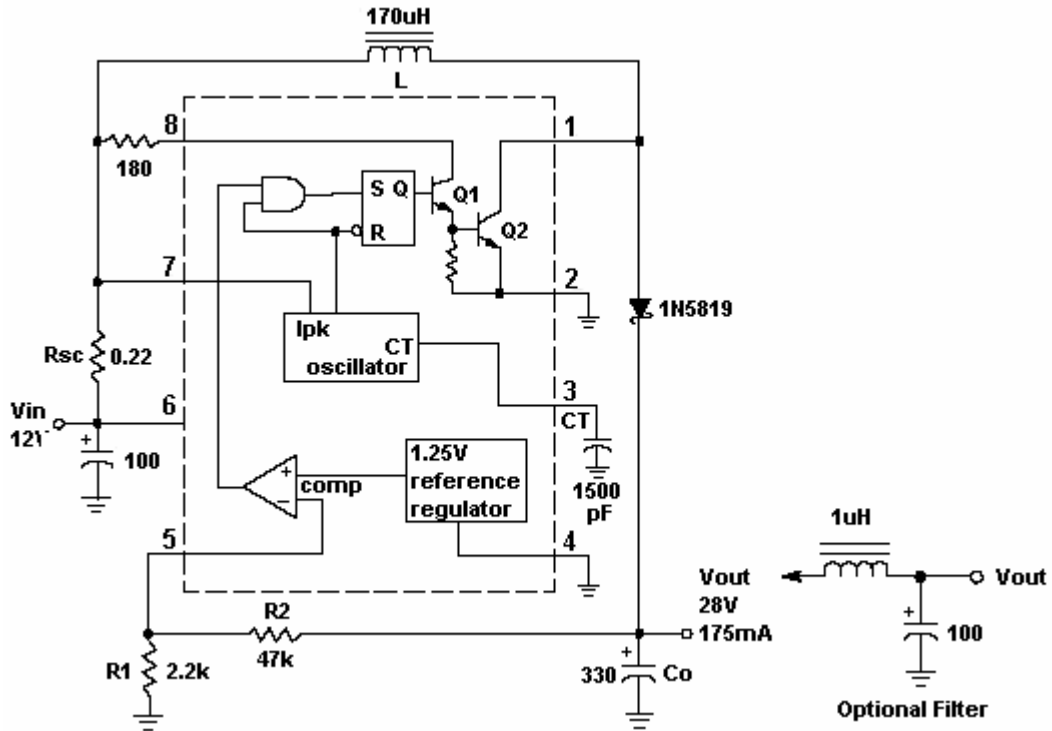

Figure 7. Step Up Converter

Test	Conditions	Results
LINE REGULATION	$V_{in} = 8V \sim 16V$ , $I_o = 175mA$	30mV +/- 0.05%
Load Regulation	$V_{in} = 12V$ , $I_o = 75mA$ to $175mA$	10mV +/- 0.017%
Output Ripple	$V_{in} = 12V$ , $I_o = 175mA$	400mVpp
Efficiency	$V_{in} = 12V$ , $I_o = 175mA$	87.7%
Output Ripple with Optional Filter	$V_{in} = 12V$ , $I_o = 175mA$	40mVpp

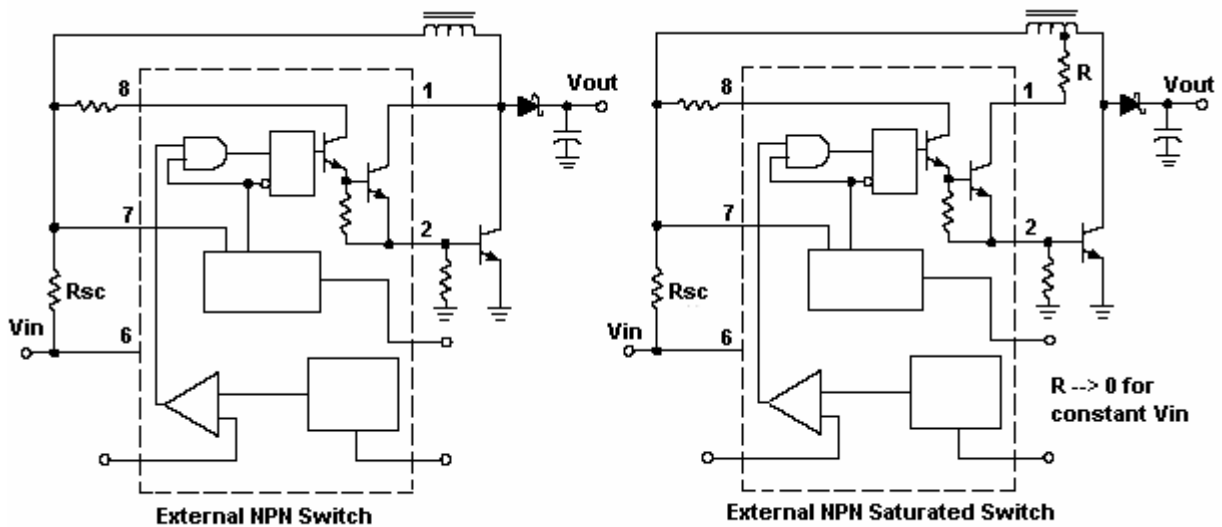

Figure 8. External Current Boost Connections for  $I_c$  Peak Greater than 1.5A

### Typical Application Circuit (continues)

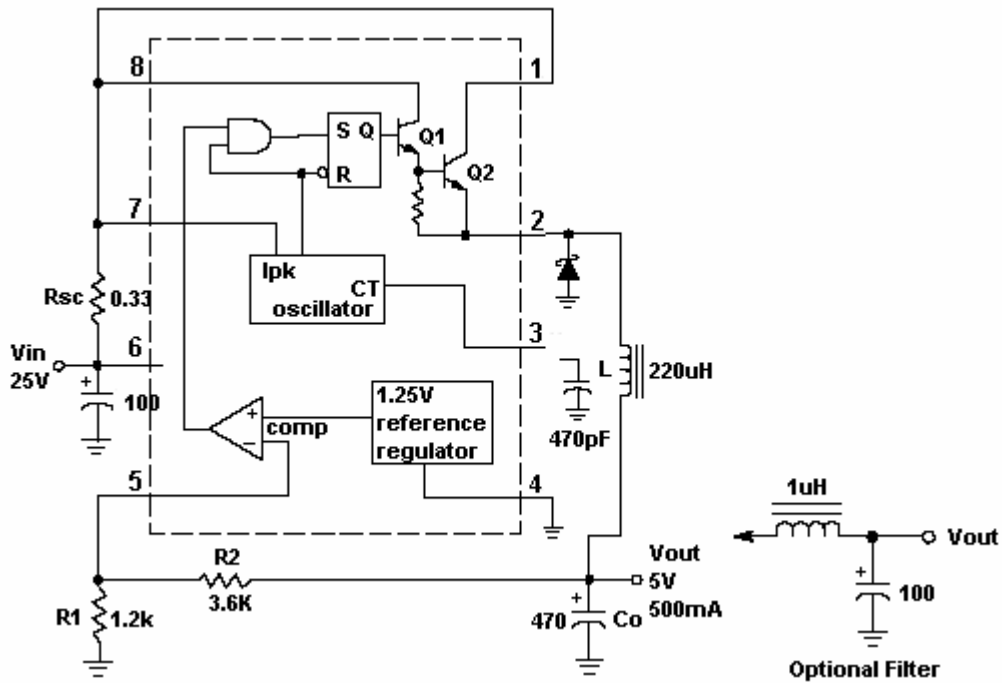

Figure 9. Step Down Converter

Test	Conditions	Results
Line Regulation	$V_{in} = 15V \sim 25V$ , $I_o = 500mA$	12mV +/- 0.12%
Load Regulation	$V_{in} = 25V$ , $I_o = 50mA$ to 500mA	3mV +/- 0.03%
Output Ripple	$V_{in} = 25V$ , $I_o = 500mA$	120mVpp
Short Circuit Current	$V_{in} = 25V$ , $R_L = 0.1\Omega$	1.1A
Efficiency	$V_{in} = 25V$ , $I_o = 500mA$	83.7%
Output Ripple with Optional Filter	$V_{in} = 25V$ , $I_o = 500mA$	40mVpp

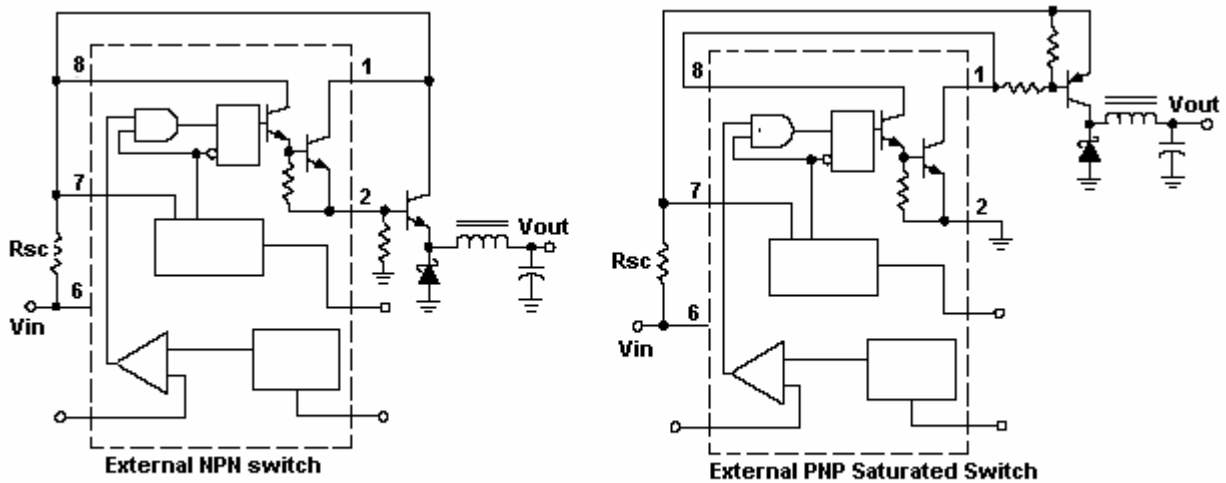

Figure 10. External Current Boost Connections for  $I_c$  Peak Greater than 1.5A

### Typical Application Circuit (continues)

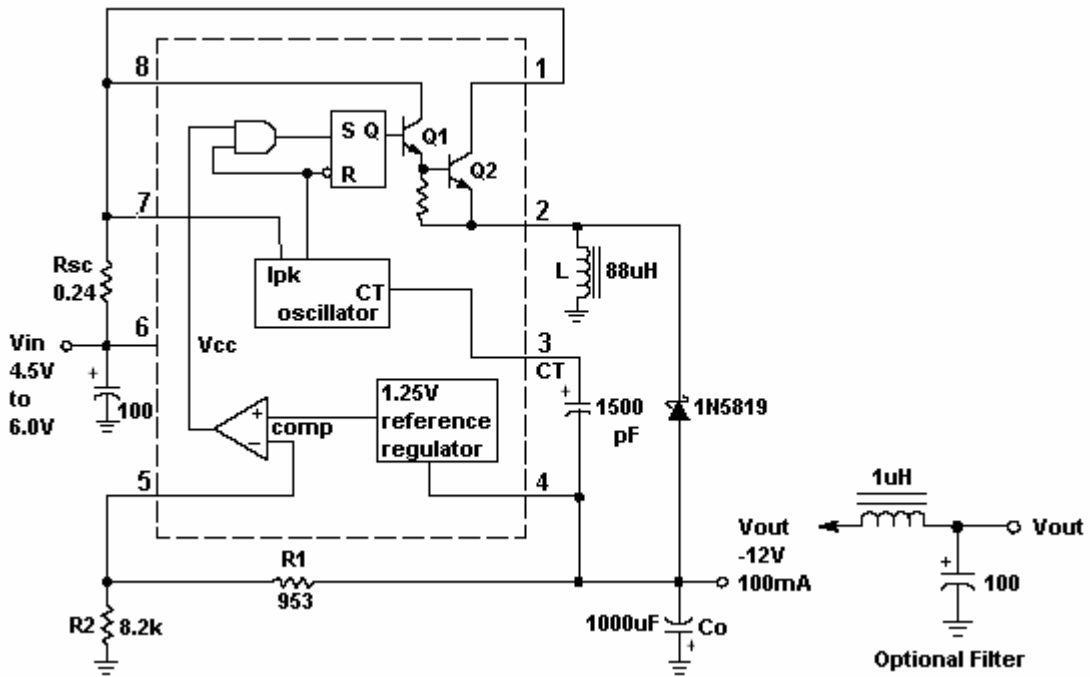

Figure 11. Voltage Inverting Converter

Test	Conditions	Results
Line Regulation	$V_{in} = 4.5V \sim 6.0V$ , $I_o = 100mA$	$3mV \pm 0.012\%$
Load Regulation	$V_{in} = 5V$ , $I_o = 10mA$ to $100mA$	$22mV \pm 0.09\%$
Output Ripple	$V_{in} = 5V$ , $I_o = 100mA$	$500mV_{pp}$
Short Circuit Current	$V_{in} = 5V$ , $R_L = 0.1ohm$	$900mA$
Efficiency	$V_{in} = 5V$ , $I_o = 100mA$	$62.2\%$
Output Ripple with Optional Filter	$V_{in} = 5V$ , $I_o = 100mA$	$70mV_{pp}$

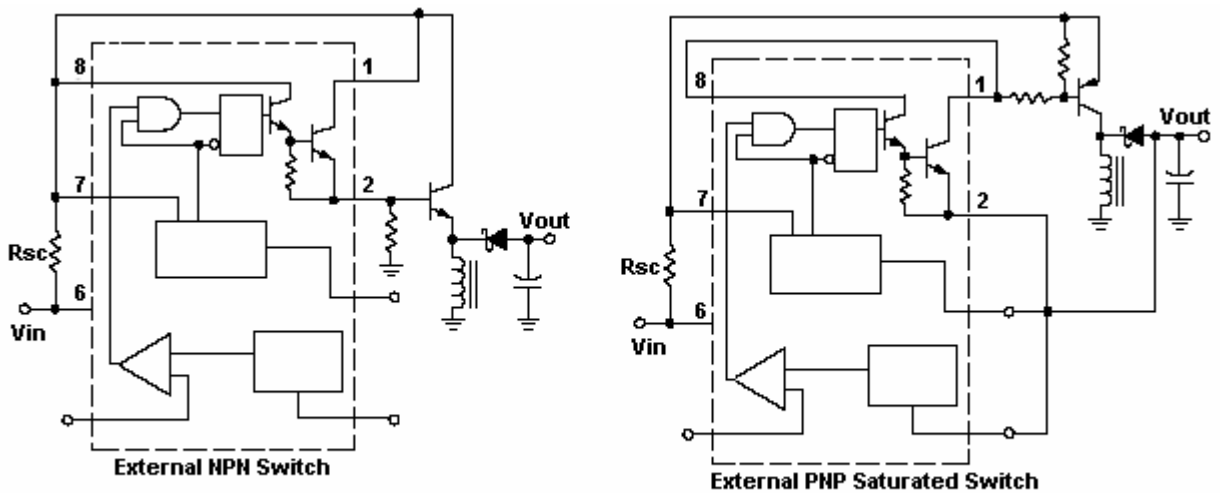

Figure 12. External Current Boost Connections for  $I_c$  Peak Greater than 1.5A

## Design Formula Table

Test	Step Up	Step Down	Voltage Inverting
$t_{on}$ $t_{off}$	$\frac{V_{out} + V_f - V_{in(min)}}{V_{cc(min)} - V_{sat}}$	$\frac{V_{out} + V_f}{V_{cc} - V_{sat} - V_{out}}$	$\frac{ V_{out}  + V_f}{V_{cc} - V_{sat}}$
( $t_{on} + t_{off}$ )	$\frac{1}{f \text{ min}}$	$\frac{1}{f \text{ min}}$	$\frac{1}{f \text{ min}}$
CT	$4.0 \times 10^{-5} t_{on}$	$4.0 \times 10^{-5} t_{on}$	$4.0 \times 10^{-5} t_{on}$
$I_{pk}(\text{switch})$	$2I_{out(max)} \left( \frac{t_{on}}{t_{off}} + 1 \right)$	$2I_{out(max)}$	$2I_{out(max)} \left( \frac{t_{on}}{t_{off}} + 1 \right)$
Rsc	$\left( \frac{0.3}{I_{pk}(\text{switch})} \right)$	$\left( \frac{0.3}{I_{pk}(\text{switch})} \right)$	$\left( \frac{0.3}{I_{pk}(\text{switch})} \right)$
L(min)	$\left( \frac{V_{in(\text{min})} - V_{sat}}{I_{pk}(\text{switch})} \right) * t_{on(\text{max})}$	$\left( \frac{V_{in(\text{min})} - V_{sat} - V_{out}}{I_{pk}(\text{switch})} \right) * t_{on(\text{max})}$	$\left( \frac{V_{in(\text{min})} - V_{sat}}{I_{pk}(\text{switch})} \right) * t_{on(\text{max})}$
Co	$\left( 9 \frac{I_{out} * t_{on}}{V_{ripple(pp)}} \right)$	$\left( \frac{I_{pk}(\text{switch})(t_{on} + t_{off})}{8V_{ripple(pp)}} \right)$	$\left( 9 \frac{I_{out} * t_{on}}{V_{ripple(pp)}} \right)$

### Terms and Definitions

- $V_{sat}$  = Saturation Voltage of the output switch.
- $V_f$  = Forward Voltage drop of the rectifier.

The following power supply characteristics must be chosen:

- $V_{in}$  = Normal input voltage
- $V_{out}$ : Desired Output voltage,  $|V_{out}| = 1.25 (1 + R_2 / R_1)$
- $I_{out}$  : Desired output current.
- $f_{min}$  : Minimum desired output switching frequency at the selected values for  $V_{in}$  and  $I_o$ .
- $V_{ripple(p-p)}$ : Desired peak-to-peak output ripple voltage. In practice, the calculated capacitor value will need to be increased due to its equivalent series resistance and board layout. The ripple voltage should be kept to a low value since it will directly affect the line and load regulation.

## SOP-8 Mechanical Drawing

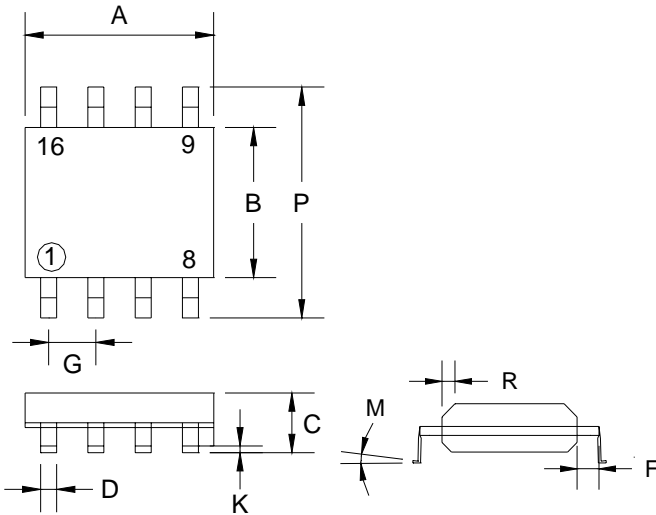

SOP-8 DIMENSION				
DIM	MILLIMETERS		INCHES	
	MIN	MAX	MIN	MAX
A	4.80	5.00	0.189	0.196
B	3.80	4.00	0.150	0.157
C	1.35	1.75	0.054	0.068
D	0.35	0.49	0.014	0.019
F	0.40	1.25	0.016	0.049
G	1.27 (typ)		0.05 (typ)	
K	0.10	0.25	0.004	0.009
M	0°	7°	0°	7°
P	5.80	6.20	0.229	0.244
R	0.25	0.50	0.010	0.019

## DIP-8 Mechanical Drawing

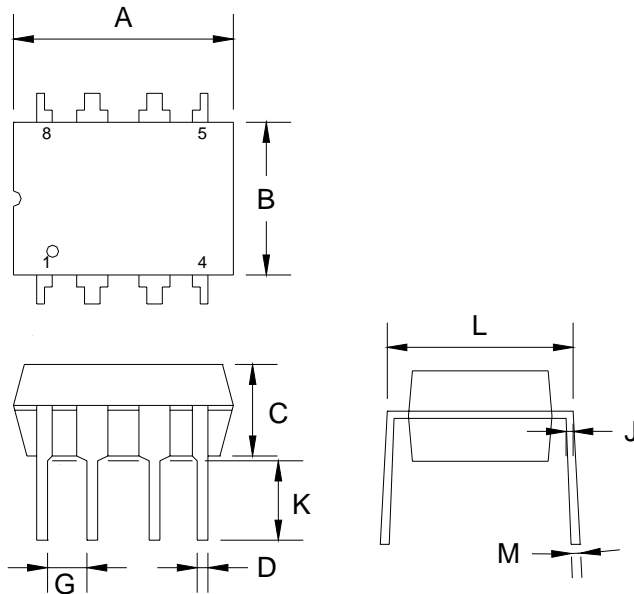

DIP-8 DIMENSION				
DIM	MILLIMETERS		INCHES	
	MIN	MAX	MIN	MAX
A	9.07	9.32	0.357	0.367
B	6.22	6.48	0.245	0.255
C	3.18	4.45	0.125	0.135
D	0.35	0.55	0.019	0.020
G	2.54 (typ)		0.10 (typ)	
J	0.29	0.31	0.011	0.012
K	3.25	3.35	0.128	0.132
L	7.75	8.00	0.305	0.315
M	-	10°	-	10°