

White LED in 5mm (T 1^{3/4}) Waterclear Package

Description

High Intensity LED with typical color coordinates $x = 0.33$, $y = 0.33$ (typical color temperature 5500 k). This LED emits white light with a high color rendering index.

The emission spectrum is tuned for ideal white, without the impression of being blue shaded or "cold". The package is a standard T 1^{3/4}.

The internal reflector is filled with a compound of TAG phosphor and an elastic resin.

Therefore the chip is better protected against temperature cycle stress.

The phosphor converts the blue emission of the InGaN chip partially to amber, which mixes with the remaining blue to produce white.

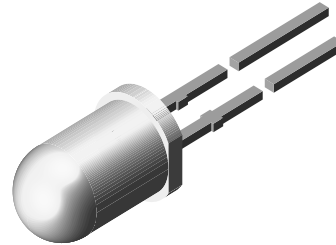

19223



Features

- High efficient InGaN technology
- Chromaticity coordinate categorized according to CIE1931 per packing unit
- Typical chromaticity coordinates $x = 0.33$; $y = 0.33$
- Typical color temperature 5500 K
- ESD class 1
- Small viewing angle, high luminous intensity
- Chip embedded in elastic resin, improved robustness against temperature cycle stress
- Lead-free device

Applications

- Indicator and backlighting
- Indoor and outdoor message panels
- Alternative to incandescent lamps
- Marker lights

Parts Table

Part	Color, Luminous Intensity	Angle of Half Intensity ($\pm\phi$)	Technology
TLHW5100	White, $I_V > 320$ mcd	9 °	InGaN / TAG on SiC

Absolute Maximum Ratings

$T_{amb} = 25$ °C, unless otherwise specified

TLHW5100

Parameter	Test condition	Symbol	Value	Unit
Reverse voltage		V_R	5	V
DC Forward current	$T_{amb} \leq 56$ °C	I_F	30	mA
Surge forward current	$t_p \leq 10$ μ s	I_{FSM}	0.1	A
Power dissipation	$T_{amb} \leq 56$ °C	P_V	126	mW
Junction temperature		T_j	100	°C
Operating temperature range		T_{amb}	- 40 to + 100	°C

Parameter	Test condition	Symbol	Value	Unit
Storage temperature range		T_{stg}	- 40 to + 100	°C
Soldering temperature	$t \leq 5$ s	T_{sd}	260	°C
Thermal resistance junction/ambient		R_{thJA}	350	K/W

Optical and Electrical Characteristics

$T_{amb} = 25$ °C, unless otherwise specified

White

TLHW5100

Parameter	Test condition	Symbol	Min	Typ.	Max	Unit
Luminous intensity ¹⁾	$I_F = 20$ mA	I_V	320	1000		mcd
Chromaticity coordinate x acc. to CIE 1931	$I_F = 20$ mA	x		0.33		
Chromaticity coordinate y acc. to CIE 1931	$I_F = 20$ mA	y		0.33		
Angle of half intensity	$I_F = 20$ mA	ϕ		± 9		deg
Forward voltage	$I_F = 20$ mA	V_F		3.5	4.2	V
Reverse voltage	$I_R = 10$ μ A	V_R	5			V
Temperature coefficient of V_F	$I_F = 20$ mA	TC_{VF}		- 4		mV/K
Temperature coefficient of I_V	$I_F = 20$ mA	TC_{IV}		- 0.5		% / K

¹⁾ in one Packing Unit $I_{Vmin}/I_{Vmax} \leq 0.5$

Chromaticity Coordinate Classification

Group	X		Y	
	min	max	min	max
3	0.280	0.325	0.210	0.340
4	0.305	0.350	0.260	0.390
5	0.330	0.375	0.310	0.440

Typical Characteristics ($T_{amb} = 25$ °C unless otherwise specified)

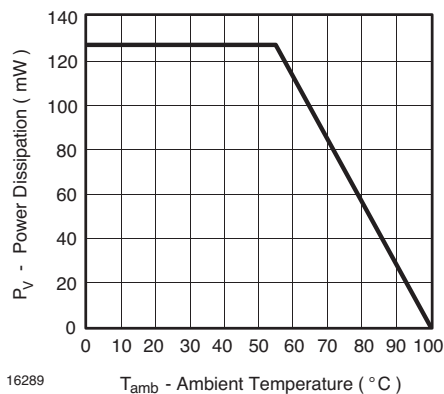

Figure 1. Power Dissipation vs. Ambient Temperature

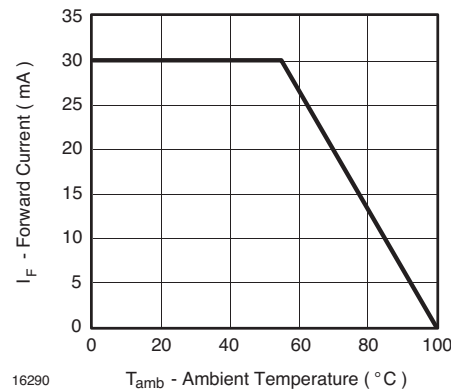

Figure 2. Forward Current vs. Ambient Temperature for AlInGaP

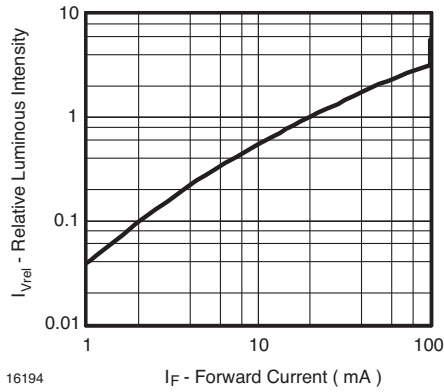

Figure 3. Relative Luminous Intensity vs. Forward Current

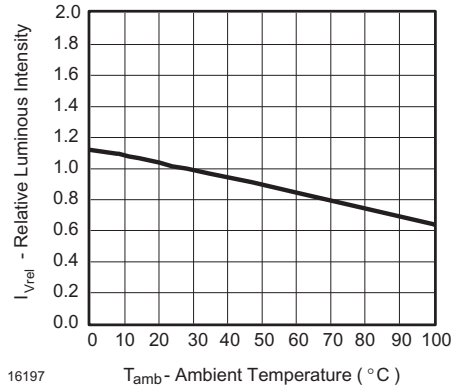

Figure 6. Rel. Luminous Intensity vs. Ambient Temperature

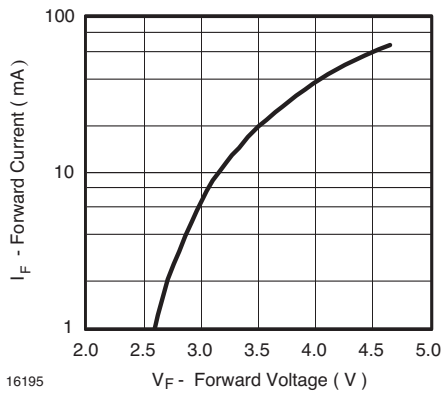

Figure 4. Forward Current vs. Forward Voltage

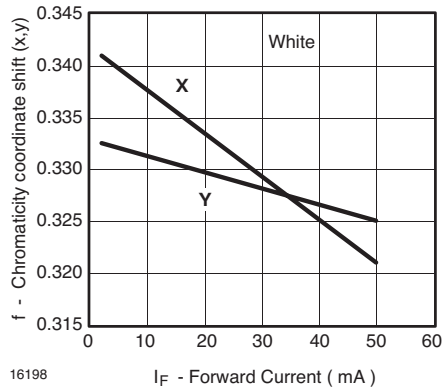

Figure 7. Chromaticity Coordinate Shift vs. Forward Current

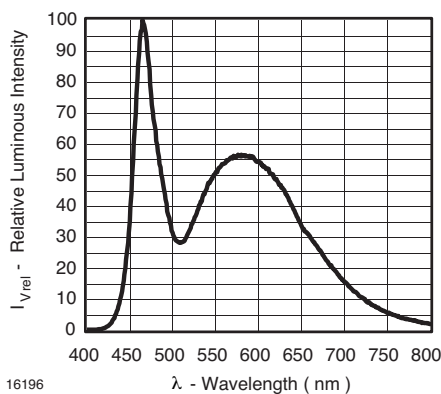

Figure 5. Relative Intensity vs. Wavelength

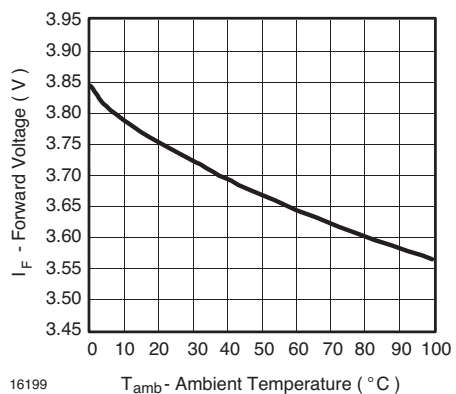
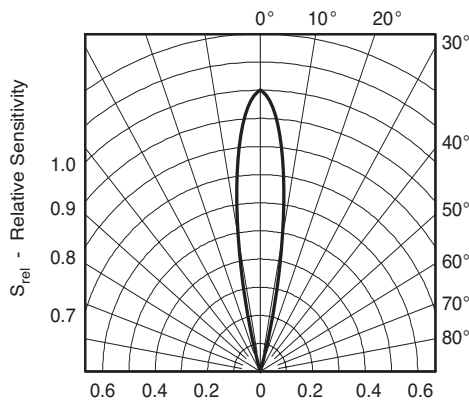
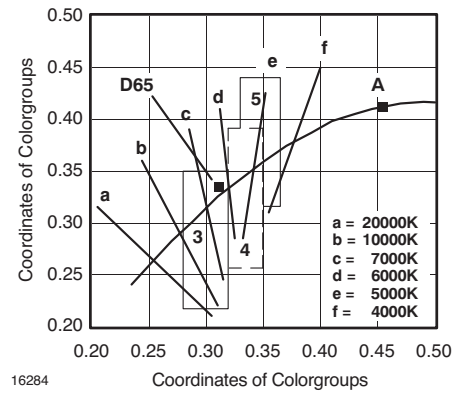

Figure 8. Forward Voltage vs. Ambient Temperature



94 8351

Figure 9. Relative Radiant Sensitivity vs. Angular Displacement



16284

Figure 10. Coordinates of Colorgroups

Package Dimensions in mm

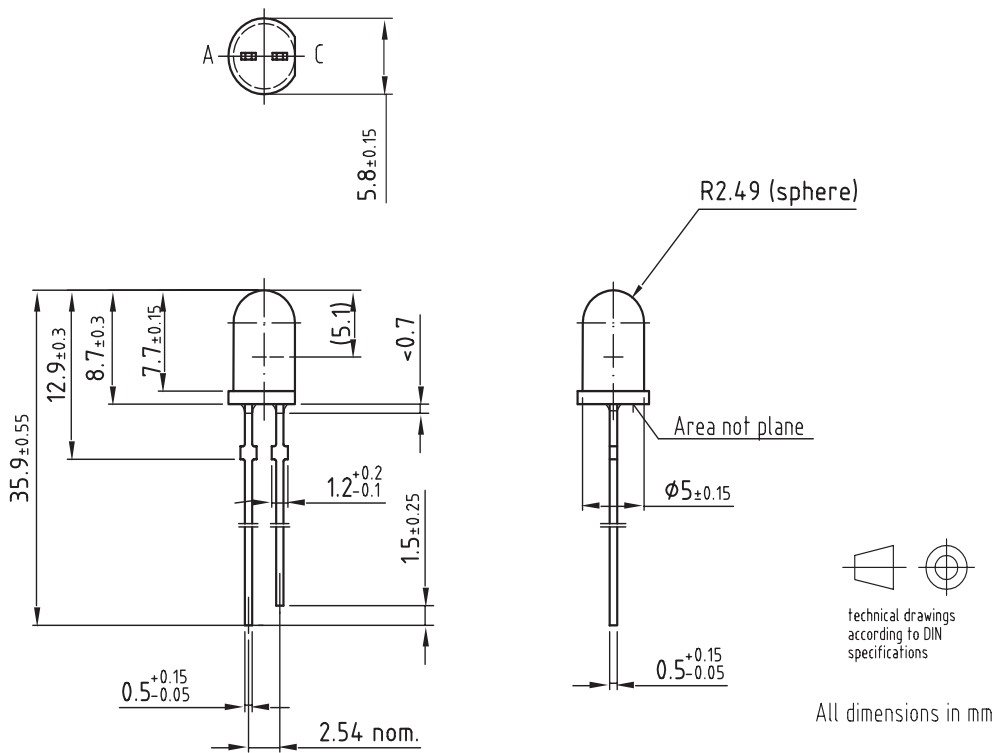

Drawing-No.: 6.544-5258.04-4
Issue: 6; 04.07.03

9612121



Ozone Depleting Substances Policy Statement

It is the policy of **Vishay Semiconductor GmbH** to

1. Meet all present and future national and international statutory requirements.
2. Regularly and continuously improve the performance of our products, processes, distribution and operating systems with respect to their impact on the health and safety of our employees and the public, as well as their impact on the environment.

It is particular concern to control or eliminate releases of those substances into the atmosphere which are known as ozone depleting substances (ODSs).

The Montreal Protocol (1987) and its London Amendments (1990) intend to severely restrict the use of ODSs and forbid their use within the next ten years. Various national and international initiatives are pressing for an earlier ban on these substances.

Vishay Semiconductor GmbH has been able to use its policy of continuous improvements to eliminate the use of ODSs listed in the following documents.

1. Annex A, B and list of transitional substances of the Montreal Protocol and the London Amendments respectively
2. Class I and II ozone depleting substances in the Clean Air Act Amendments of 1990 by the Environmental Protection Agency (EPA) in the USA
3. Council Decision 88/540/EEC and 91/690/EEC Annex A, B and C (transitional substances) respectively.

Vishay Semiconductor GmbH can certify that our semiconductors are not manufactured with ozone depleting substances and do not contain such substances.

**We reserve the right to make changes to improve technical design
and may do so without further notice.**

Parameters can vary in different applications. All operating parameters must be validated for each customer application by the customer. Should the buyer use Vishay Semiconductors products for any unintended or unauthorized application, the buyer shall indemnify Vishay Semiconductors against all claims, costs, damages, and expenses, arising out of, directly or indirectly, any claim of personal damage, injury or death associated with such unintended or unauthorized use.

Vishay Semiconductor GmbH, P.O.B. 3535, D-74025 Heilbronn, Germany
Telephone: 49 (0)7131 67 2831, Fax number: 49 (0)7131 67 2423