

**VI TELEFILTER****Filter specification****TFS 70H22****1/5****1. Measurement condition :**

Ambient temperature  $T_A$ : 25 °C.  
 Input power level: 0 dBm.  
 Terminating impedances in  $f_C$  \* ) :  
 for input: 180  $\Omega$  | - 17,6 pF.  
 for output: 240  $\Omega$  | - 13,7 pF.

**2. Characteristics :**

Remark:

Reference level for the relative attenuation  $a_{rel}$  of the **TFS 70H22** is the minimum of the pass band attenuation  $a_{min}$ . The minimum of the pass band attenuation  $a_{min}$  is defined as the insertion loss  $a_e$ . The reference frequency  $f_C$  is the arithmetic mean value of the upper and lower frequencies at the 20 dB filter attenuation level relative to the insertion loss  $a_e$ . The temperature coefficient of frequency  $T_{Cf}$  is valid both for the reference frequency  $f_C$  and the frequency response of the filter in the operating temperature range. The frequency shift of the filter in the operating temperature range is not included in the production tolerance scheme.

Data	typ. value	tolerance / limit
<b>Insertion loss (Reference level) <math>a_e</math></b>	17 dB	max. 24 dB
<b>Centre frequency <math>f_C</math> at ambient temperature (<math>f_{CTA}</math>)</b>	70,0 MHz	70,0 $\pm$ 0,05 MHz
<b>Pass band : PB</b>		$f_C \dots f_C \pm 155$ kHz
<b>Amplitude ripple in : <math>f_C - 155</math> kHz ... <math>f_C + 155</math> kHz</b>	-	max. 1 dB
<b>Bandwidth ( BW ) : at ambient temperature <math>T_A</math></b>		
1 dB	350 kHz	min. 310 kHz
3 dB	595 kHz	min. 500 kHz
10 dB	1020 kHz	
20 dB	1360 kHz	
40 dB	1735 kHz	max. 1900 kHz
50 dB	1880 kHz	
<b>Relative attenuation <math>a_{rel}</math></b>		
$f_C - 155$ kHz ..... $f_C + 155$ kHz	-	max. 1 dB
$f_C \pm 155$ kHz ..... $f_C \pm 250$ kHz	-	max. 3 dB
$f_C \pm 950$ kHz ..... $f_C \pm 3$ MHz	55 dB	min. 40 dB
$f_C \pm 3$ MHz ..... $f_C \pm 9$ MHz	55 dB	min. 45 dB
$f_C \pm 9$ kHz ..... $f_C \pm 30$ MHz	65 dB	min. 50 dB
<b>Group delay ( mean value in PB ) :</b>	2,8 $\mu$ s	
<b>Group delay ripple in <math>f_C \dots f_C \pm 250</math> kHz :</b>	100 ns	max. 300 ns
<b>Deviation from linear phase in PB :</b>	1,4 °	max. 3 °
<b>Triple transit attenuation compared to main signal</b>	48 dB	
<b>Crosstalk</b>	55 dB	
<b>Frequency inversion temperature ( <math>T_o</math> ) :</b>	30°C...35°C	
<b>Temperature coefficient of frequency ( <math>T_{Cf}</math> ) :</b>	-0,036 ppm/K <sup>2</sup>	
<b>Frequency deviation of <math>f_C</math> over temperature: ** )</b>	$\Delta f_C(\text{Hz}) = T_{Cf}(\text{ppm/K}) \times (T - T_o)^2 \times f_{T_o}(\text{MHz})$	
<b>Operating temperature range</b>		- 25 °C ... + 80 °C
<b>Storage temperature range</b>		- 40 °C ... + 85 °C

\*) The terminating impedances depend on parasitics and q-values of matching elements and the board used, and are to be understood as reference values only. Should there be additional questions do not hesitate to ask for an application note or contact our design team.

\*\*)  $f_{T_o}$  is reference frequency  $f_C$  at frequency inversion temperature ( $T_o$ )

**Generated:****W. Dunsow****Checked/Approved:****Dr. Bert Wall**

**VI TELEFILTER**  
 Potsdamer Straße 18  
 D 14 513 TELTOW / Germany  
 Tel: (+49) 3328 4784-0 / Fax: (+49) 3328 4784-30  
 E-Mail: [tft@telefilter.com](mailto:tft@telefilter.com)

**Vectron International, Inc.**  
 267 Lowell Road  
 Hudson, NH 03051 / USA  
 Tel: (603) 598-0070 Fax: (603) 598-0075  
 E-Mail: [vti@vtinh.com](mailto:vti@vtinh.com)

VI TELEFILTER reserves the right to make changes to the product(s) and/or information contained herein without notice. No liability is assumed as a result of their use or application. No rights under any patent accompany the sale of any such product(s) or information

**3. Construction and pin connection :** ( all dimensions in mm)

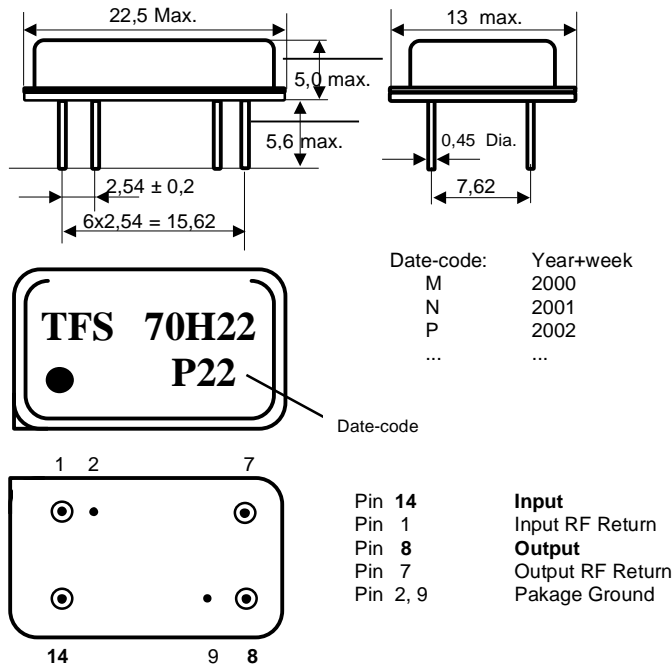

**4. 50 Ω matching network ( please refer to the application note for further details ) :**

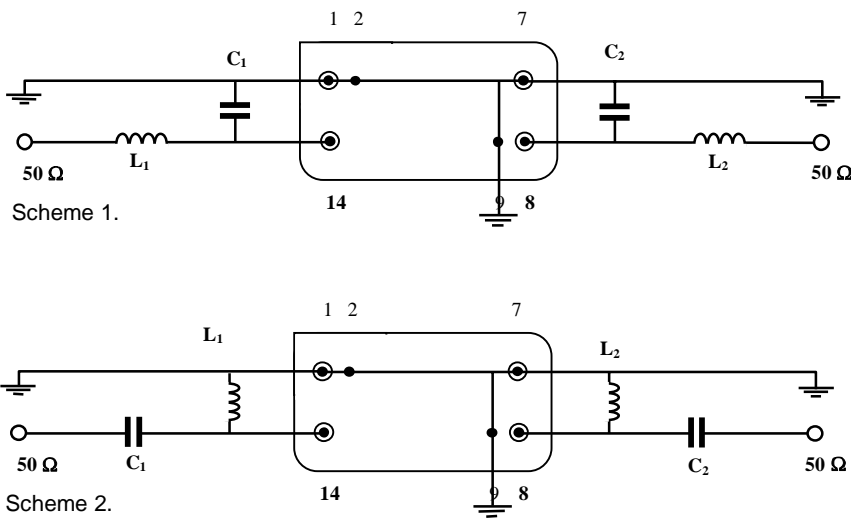

**VI TELEFILTER**  
 Potsdamer Straße 18  
 D 14 513 TELTOW / Germany  
 Tel: (+49) 3328 4784-0 / Fax: (+49) 3328 4784-30  
 E-Mail: [tft@telefilter.com](mailto:tft@telefilter.com)

**Vectron International, Inc.**  
 267 Lowell Road  
 Hudson, NH 03051 / USA  
 Tel: (603) 598-0070 Fax: (603) 598-0075  
 E-Mail: [vti@vtinh.com](mailto:vti@vtinh.com)

VI TELEFILTER reserves the right to make changes to the product(s) and/or information contained herein without notice. No liability is assumed as a result of their use or application. No rights under any patent accompany the sale of any such product(s) or information

**5. Stability characteristics :**

After the following tests the filter shall meet the whole specification:

1. Shock: 500g, 18 ms, half sine wave, 3 shocks each plane;  
DIN IEC 68 T2 - 27
2. Vibration: 10 Hz to 500 Hz, 0,35 mm or 5g respectively, 1 octave per min, 10 cycles per plan, 3 plans;  
DIN IEC 68 T2 - 6
3. Change of temperature: -55 °C to 125°C / 30 min. each / 10 cycles  
DIN IEC 68 part 2 – 14 Test N
4. Resistance to solder heat (reflow): reflow possible: twice max.;  
for temperature conditions, please refer to the attached "Air reflow temperature conditions" on page 4;

## 6. Air reflow temperature conditions :

1st and 2nd air reflow profile

Name:	pre-heating periods	main-heating periods	peak temperature
Temperature:	150 °C - 170 °C	over 200 °C	255 °C ± 5 °C
Time:	60 sec. - 90 sec.	20 sec. - 25 sec.	

Air reflow profile

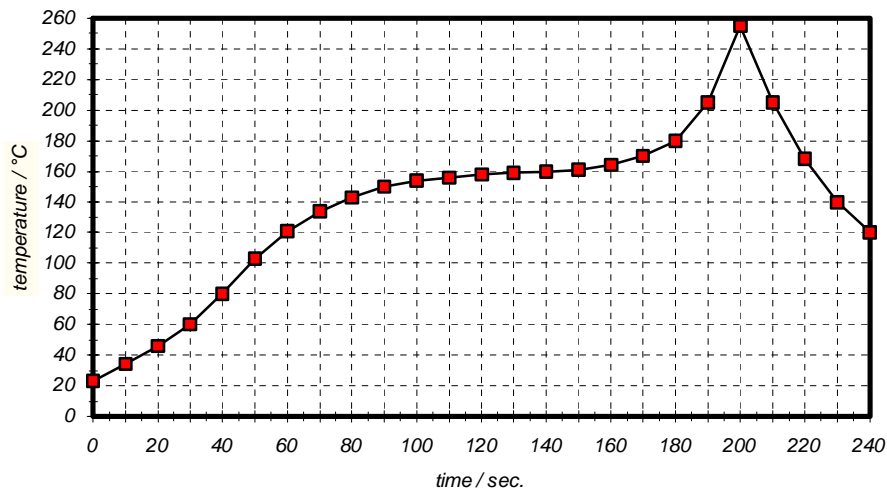

Table for temperature vs. time during the air reflow process

Tolerance of temperatures: ± 5 °C

time / sec.	temperature / °C	time / sec.	temperature / °C
0	23	140	160
10	34	150	161
20	46	160	164
30	60	170	170
40	80	180	180
50	103	190	205
60	121	195	230
70	134	200	255
80	143	205	230
90	150	210	205
100	154	215	180
110	156	220	165
120	158	230	140
130	159	240	120

VI TELEFILTER  
 Potsdamer Straße 18  
 D 14 513 TELTOW / Germany  
 Tel: (+49) 3328 4784-0 / Fax: (+49) 3328 4784-30  
 E-Mail: [tft@telefilter.com](mailto:tft@telefilter.com)

Vectron International, Inc.  
 267 Lowell Road  
 Hudson, NH 03051 / USA  
 Tel: (603) 598-0070 Fax: (603) 598-0075  
 E-Mail: [vti@vtinh.com](mailto:vti@vtinh.com)

VI TELEFILTER reserves the right to make changes to the product(s) and/or information contained herein without notice. No liability is assumed as a result of their use or application. No rights under any patent accompany the sale of any such product(s) or information

---

**VI TELEFILTER****Filter specification****TFS 70H22****5/5**

---

**History**

<b>Version</b>	<b>Reason of changes</b>	<b>Name</b>	<b>Date</b>
1.0	Generate preliminary specification according to customer requirements.	Dunzow W.	15.10.2001.
1.1	Generate filter specification.	Dunzow W.	04.03.2002.

---

**VI TELEFILTER**  
**Potsdamer Straße 18**  
**D 14 513 TELTOW / Germany**  
**Tel: (+49) 3328 4784-0 / Fax: (+49) 3328 4784-30**  
**E-Mail: [tft@telefilter.com](mailto:tft@telefilter.com)**

---

**Vectron International, Inc.**  
**267 Lowell Road**  
**Hudson, NH 03051 / USA**  
**Tel: (603) 598-0070 Fax: (603) 598-0075**  
**E-Mail: [yti@vtinh.com](mailto:yti@vtinh.com)**

---

VI TELEFILTER reserves the right to make changes to the product(s) and/or information contained herein without notice. No liability is assumed as a result of their use or application. No rights under any patent accompany the sale of any such product(s) or information