



## ST3237E

± 15KV ESD-protected, 1µA, 3 to 5.5V, 250Kbps  
RS-232 Transceiver with stand-by

### Feature summary

- ESD protection for RS-232 I/O pins
  - ±15KV human body model
  - ±8KV IEC 1000-4-2 contacts discharge
- 1µA low power shutdown with receivers active
- Guaranteed data rate
  - 250Kbps (normal operation)
  - 1Mbps (very high speed operation)
- Guaranteed slew rate range
  - 6V/µs (normal operation)
  - 24V/µs (very high speed operation)
- 0.1µF external capacitors
- Flow-through pinout
- Low supply current 300µA
- Available in SSOP-28 and SO-28

### Description

The ST3237E is a 3V to 5.5V powered EIA/TIA-232 and V.28/V.24 communication interfaces high data-rate capability and enhanced electrostatic discharge (ESD) protection at ±8KV using IEC1000-4-2 contact discharge and ±15kV using Human Body Model (HBM). The other pins are protected with standard ESD protection at ±2kV using HBM method. The ST3237C is a

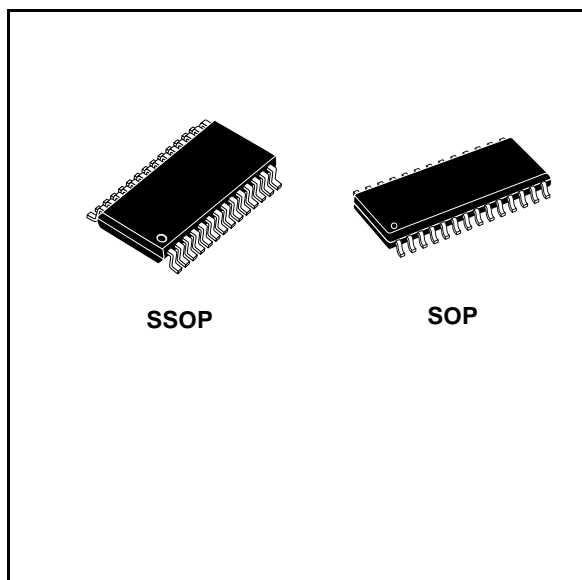

transceiver (5 drivers, 3 receivers) for fast modem applications.

The device has a proprietary low-dropout transmitter output stage providing true RS-232 performance from a 3V to 5.5V supply using a dual charge pump. The device is guaranteed to run at data rates of 250Kbps in the normal operation mode and 1Mbps in the very high speed operation mode while maintaining RS-232 output levels..

### Order codes

Part number	Temperature range	Package	Comments
ST3237EBDR	-40 to 85 °C	SO-28 (Tape & Reel)	1000 parts per reel
ST3237ECPR	0 to 70 °C	SSOP-28 (Tape & Reel)	1350 parts per reel
ST3237EBPR	-40 to 85°C	SSOP-28 (Tape & Reel)	1350 parts per reel

# Contents

1	Pin configuration .....	3
2	Absolute maximum ratings .....	5
3	Electrical characteristics .....	6
4	Application circuits .....	8
5	Typical performance characteristics .....	9
6	Application note .....	10
7	Revision history .....	16

# 1 Pin configuration

Figure 1. Pin connection

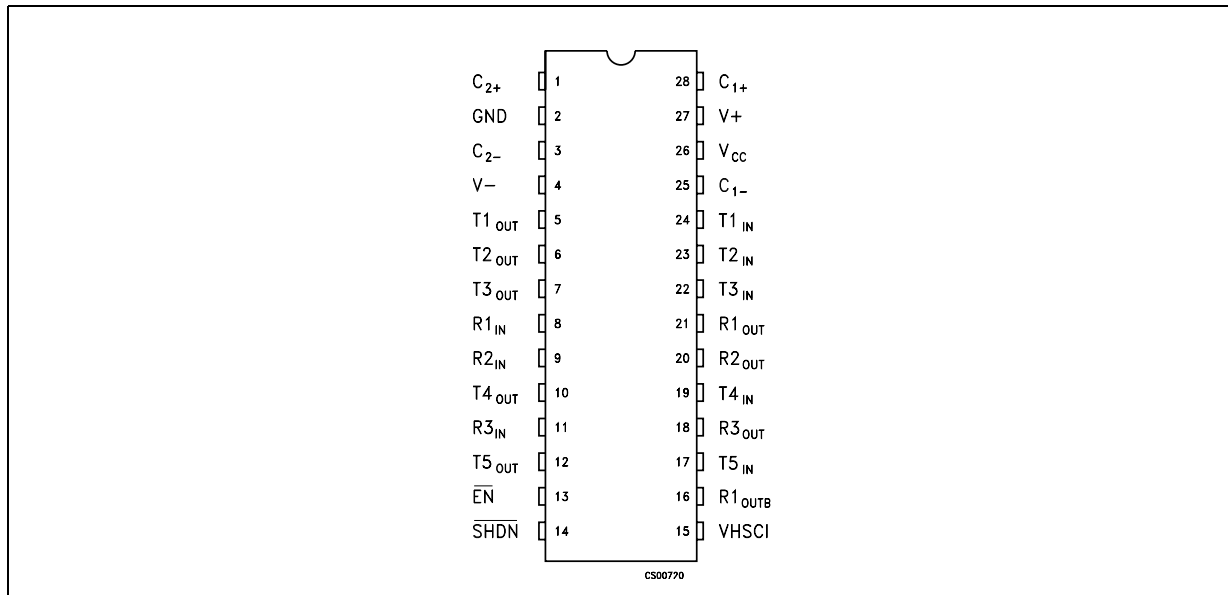

Table 1. Pin description

PIN N°	SYMBOL	NAME AND FUNCTION
1	C <sub>2+</sub>	Positive Terminal of Inverting Charge Pump Capacitor
2	GND	Ground
3	C <sub>2-</sub>	Negative Terminal of Inverting Charge Pump Capacitor
4	V-	5.5V Generated by the Charge Pump
5	T1 <sub>OUT</sub>	First Transmitter Output Voltage
6	T2 <sub>OUT</sub>	Second Transmitter Output Voltage
7	T3 <sub>OUT</sub>	Third Transmitter Output Voltage
8	R1 <sub>IN</sub>	First Receiver Input Voltage
9	R2 <sub>IN</sub>	Second Receiver Input Voltage
10	T4 <sub>OUT</sub>	Fourth Transmitter Output Voltage
11	R3 <sub>IN</sub>	Third Receiver Input Voltage
12	T5 <sub>OUT</sub>	Fifth Transmitter Output Voltage
13	EN	Receiver Enable, Active Low
14	SHDN	Shutdown Control, Active Low
15	VHSCI	Very High Speed Control Input. Connect to GND for normal operation; connect to VCC for 1Mbps transmission rates.
16	R1 <sub>OUTB</sub>	Non Inverting Complementary Receiver Output. Always Active.
17	T5 <sub>IN</sub>	Fifth Transmitter Input Voltage
18	R3 <sub>OUT</sub>	Third Receiver Output Voltage

Table 1. Pin description

PIN N°	SYMBOL	NAME AND FUNCTION
19	T <sub>4IN</sub>	Fourth Transmitter Input Voltage
20	R <sub>2OUT</sub>	Second Receiver Output Voltage
21	R <sub>1OUT</sub>	First Receiver Output Voltage
22	T <sub>3IN</sub>	Third Transmitter Input Voltage
23	T <sub>2IN</sub>	Second Transmitter Input Voltage
24	T <sub>1N</sub>	First Transmitter Input Voltage
25	C <sub>1-</sub>	Negative Terminal of Voltage- Charge Pump Capacitor
26	V <sub>CC</sub>	Supply Voltage
27	V+	-5.5V Generated by the Charge Pump
28	C <sub>1+</sub>	Positive Terminal of Voltage- Charge Pump Capacitor

## 2 Absolute maximum ratings

**Table 2. Absolute maximum ratings**

Symbol	Parameter	Value	Unit
$V_{CC}$	Supply voltage	-0.3 to 6	V
V+	Doubled voltage terminal	-0.3 to 7	V
V-	Inverted voltage terminal	0.3 to -7	V
$V+ +  V- $		13	V
$T_{IN}$	Transmitter input voltage range	-0.3 to 6	V
$\overline{SHDN}, \overline{EN}$		-0.3 to 6	V
VHSCI	Very high speed control input	-0.3 to ( $V_{CC} + 0.3$ )	V
$R_{IN}$	Receiver input voltage range	$\pm 25$	V
$T_{OUT}$	Transmitter output voltage range	$\pm 13.2$	V
$R_{OUT}, R_{OUTB}$	Receiver output voltage range	-0.3 to ( $V_{CC} + 0.3$ )	V
$t_{SHORT}$	Short circuit duration on $T_{OUT}$ (one at a time)	Continuous	
$T_{stg}$	Storage temperature range	-65 to 150	°C

*Note:* Absolute Maximum Ratings are those values beyond which damage to the device may occur. Functional operation under these condition is not implied. V+ and V- can have a maximum magnitude of +7V, but their absolute addition can not exceed 13 V.

**Table 3. Shutdown and enable control truth table**

SHDN	EN	T-OUT	R-OUT	R-OUTB
0	0	High Z	Active	Active
0	1	High Z	High Z	Active
1	0	Active	Active	Active
1	1	Active	High Z	Active

**Figure 2. ESD performance: transmitter outputs, receiver inputs**

Symbol	Parameter	Test conditions	Min.	Typ.	Max.	Unit
ESD	ESD protection voltage	Human body model	$\pm 15$			kV
ESD	ESD protection voltage	IEC-1000-4-2 contact discharge	$\pm 8$			kV

### 3 Electrical characteristics

**Table 4. Electrical characteristics** ( $C_1 - C_4 = 0.1\mu\text{F}$ ,  $V_{CC} = 3\text{V}$  to  $5.5\text{V}$ ,  $T_A = -40$  to  $85^\circ\text{C}$ , unless otherwise specified. Typical values are referred to  $T_A = 25^\circ\text{C}$ )

Symbol	Parameter	Test conditions	Min.	Typ.	Max.	Unit
$I_{\text{SUPPLY}}$	$V_{CC}$ Power Supply Current	$\overline{\text{SHDN}}=V_{CC}$ , No Load		0.3	1	mA
$I_{\text{SHDN}}$	Shutdown Supply Current	$\text{SHDN}=\text{GND}$ , $V_{T\_IN}=\text{GND}$ or $V_{CC}$		1	5	$\mu\text{A}$

**Table 5. Logic input** ( $C_1 - C_4 = 0.1\mu\text{F}$ ,  $V_{CC} = 3\text{V}$  to  $5.5\text{V}$ ,  $T_A = -40$  to  $85^\circ\text{C}$ , unless otherwise specified. Typical values are referred to  $T_A = 25^\circ\text{C}$ )

Symbol	Parameter	Test conditions	Min.	Typ.	Max.	Unit
$V_{\text{TIL}}$	Input Logic Threshold Low (Note 1)	T-IN, VHSCI, $\overline{\text{EN}}$ , $\overline{\text{SHDN}}$			0.8	V
$V_{\text{TIH}}$	Input Logic Threshold High	T-IN, VHSCI, $\overline{\text{EN}}$ , $\overline{\text{SHDN}}$	$V_{CC} = 3.3\text{V}$	2		V
			$V_{CC} = 5\text{V}$	2.4		
$I_{\text{IL}}$	Input Leakage Current	T-IN, VHSCI, $\overline{\text{EN}}$ , $\overline{\text{SHDN}}$			$\pm 1.0$	$\mu\text{A}$
$V_{\text{HYS}}$	Transmitter Input Hysteresis			0.25		V

Note: Transmitter input hysteresis is typically 250mV

**Table 6. Transmitter** ( $C_1 - C_4 = 0.1\mu\text{F}$  tested at  $3.3\text{V}\pm 10\%$ ,  $V_{CC} = 3\text{V}$  to  $5.5\text{V}$ ,  $T_A = -40$  to  $85^\circ\text{C}$ , unless otherwise specified. Typical values are referred to  $T_A = 25^\circ\text{C}$ )

Symbol	Parameter	Test conditions	Min.	Typ.	Max.	Unit
$V_{\text{TOUT}}$	Output voltage swing	All transmitter outputs are loaded with $3\text{K}\Omega$ to GND	$\pm 5$	$\pm 5.4$		V
$R_{\text{TOUT}}$	Transmitter output resistance	$V_{CC} = 0\text{V}$ , $V_{\text{OUT}} = \pm 2\text{V}$	300	10M		W
$I_{\text{SC}}$	Output short circuit current			$\pm 60$		mA
$I_{\text{TOL}}$	Output leakage current	$V_{CC} = 0\text{V}$ or $3.3\text{V}$ to $5.5\text{V}$ $V_{\text{OUT}} = \pm 12\text{V}$ Transmitters disable			$\pm 25$	$\mu\text{A}$

**Table 7. Receiver** ( $C_1 - C_4 = 0.1\mu\text{F}$  tested at  $3.3\text{V}\pm 10\%$ ,  $V_{\text{CC}} = 3\text{V}$  to  $5.5\text{V}$ ,  $T_A = -40$  to  $85^\circ\text{C}$ , unless otherwise specified. Typical values are referred to  $T_A = 25^\circ\text{C}$ )

Symbol	Parameter	Test conditions	Min.	Typ.	Max.	Unit
$I_{\text{OL}}$	Output leakage current	Receiver disabled, $\overline{\text{EN}} = V_{\text{CC}}$		$\pm 0.05$	$\pm 10$	$\mu\text{A}$
$V_{\text{OL}}$	Output voltage low	$I_{\text{OUT}} = 1\text{mA}$			0.4	V
$V_{\text{OH}}$	Output voltage high	$I_{\text{OUT}} = -1\text{mA}$	$V_{\text{CC}}-0.6$	$V_{\text{CC}}-0.1$		V
$V_{\text{RIN}}$	Receiver input voltage operating range		-25		25	V
$V_{\text{RIL}}$	RS-232 input threshold low	$T_A = 25^\circ\text{C}$ , $V_{\text{CC}} = 3.3\text{V}$	0.6	1.1		V
		$T_A = 25^\circ\text{C}$ , $V_{\text{CC}} = 5\text{V}$	0.8	1.5		
$V_{\text{RIH}}$	RS-232 input threshold high	$T_A = 25^\circ\text{C}$ , $V_{\text{CC}} = 3.3\text{V}$		1.5	2.4	V
		$T_A = 25^\circ\text{C}$ , $V_{\text{CC}} = 5\text{V}$		1.2	2.4	
$V_{\text{RIHYS}}$	Input hysteresis			0.3		V
$R_{\text{RIN}}$	Input resistance	$T_A = 25^\circ\text{C}$	3	5	7	$\text{K}\Omega$

**Table 8. Timing characteristics** ( $C_1 - C_4 = 0.1\mu\text{F}$  tested at  $3.3\text{V}\pm 10\%$ ,  $V_{\text{CC}} = 3\text{V}$  to  $5.5\text{V}$ ,  $T_A = -40$  to  $85^\circ\text{C}$ , unless otherwise specified. Typical values are referred to  $T_A = 25^\circ\text{C}$ )

Symbol	Parameter	Test conditions	Min.	Typ.	Max.	Unit
$D_{\text{R}}$	Maximum data rate	$R_L = 3\text{K}\Omega$ , $C_L = 1000\text{pF}$ one transmitter switching, $\text{VHSCI}=\text{GND}$	250			Kbps
		$R_L = 3\text{K}\Omega$ , $C_L = 250\text{pF}$ one transmitter switching, $\text{VHSCI}=V_{\text{CC}}$ $V_{\text{CC}} = 3$ to $4.5\text{V}$	1000			Kbps
		$R_L = 3\text{K}\Omega$ , $C_L = 1000\text{pF}$ one transmitter switching, $\text{VHSCI}=V_{\text{CC}}$ $V_{\text{CC}} = 4.5$ to $5.5\text{V}$	1000			Kbps
$t_{\text{PHLR}}$ $t_{\text{PLHR}}$	Propagation delay input to output	$R_{\text{IN}}$ to $R_{\text{OUT}}$ , $C_L = 150\text{pF}$		0.15		$\mu\text{s}$
$t_{\text{PHLR}}$ $t_{\text{PLHR}}$	Propagation delay input to output	$R_L = 3\text{k}\Omega$ , $C_L = 1000\text{pF}$ , $\text{VHSCI}=V_{\text{CC}}$ $\text{VHSCI}=\text{GND}$		400 1000		ns ns
$t_{\text{T\_SKEW}}$	Transmitter skew	$ t_{\text{PHL}} - t_{\text{TLH}} $ , $\text{VHSCI}=\text{GND}$		300		ns
		$ t_{\text{PHL}} - t_{\text{TLH}} $ , $\text{VHSCI}=V_{\text{CC}}$		50		ns
$t_{\text{R\_SKEW}}$	Receiver skew	$ t_{\text{PHL}} - t_{\text{TLH}} $		100		ns
$t_{\text{OER}}$	Receiver output enable time	Normal operation		50		ns
$t_{\text{ODR}}$	Receiver output disable time	Normal operation		120		ns
$S_{\text{RT}}$	Transition slew rate	$T_A = 25^\circ\text{C}$ $R_L = 3$ to $7\text{K}\Omega$ , $V_{\text{CC}} = 3.3\text{V}$ measured from $+3\text{V}$ to $-3\text{V}$ or $-3\text{V}$ to $+3\text{V}$ $C_L = 150\text{pF}$ to $1000\text{pF}$ , $\text{VHSCI}=\text{GND}$	6		30	$\text{V}/\mu\text{s}$
		$C_L = 150\text{pF}$ to $1000\text{pF}$ , $\text{VHSCI}=V_{\text{CC}}$	24		150	$\text{V}/\mu\text{s}$
		$C_L = 150\text{pF}$ to $2500\text{pF}$ , $\text{VHSCI}=\text{GND}$	4		30	$\text{V}/\mu\text{s}$

Note: Transmitter Skew is measured at the transmitter zero cross points

# 4 Application circuits

Figure 3. Application circuits

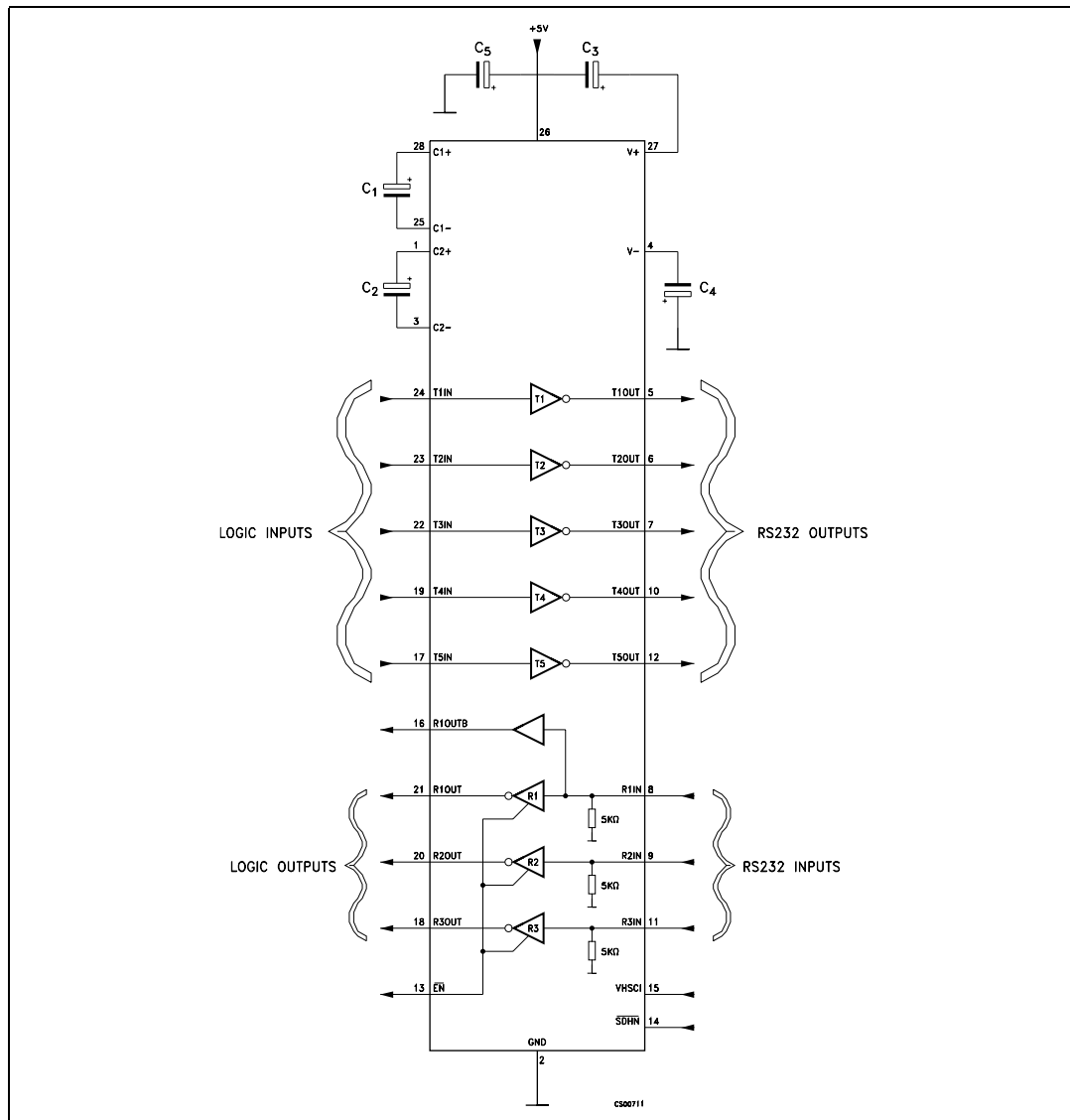

Table 9. Capacitance value (μF)

V <sub>CC</sub>	C1	C2	C3	C4	C <sub>bypass</sub>
3.0 to 3.6	0.22	0.22	0.22	0.22	0.1
3.1 to 3.6	0.1	0.1	0.1	0.1	0.1
4.5 to 5.5	0.047	0.33	0.33	0.33	0.1
3.0 to 5.5	0.22	0.1	0.1	0.1	0.1



# 5 Typical performance characteristics

(unless otherwise specified  $T_J = 25^\circ\text{C}$ )

**Figure 4. Low level receiver output current**

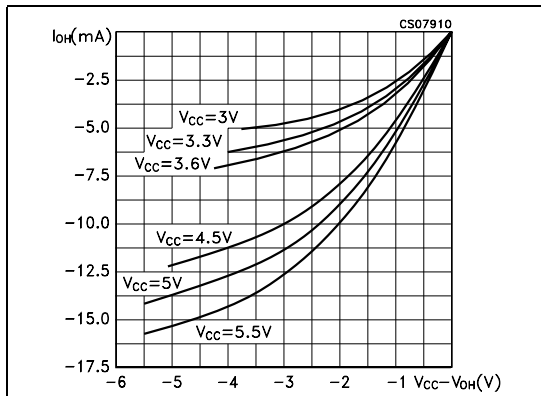

**Figure 5. High level receiver output current**

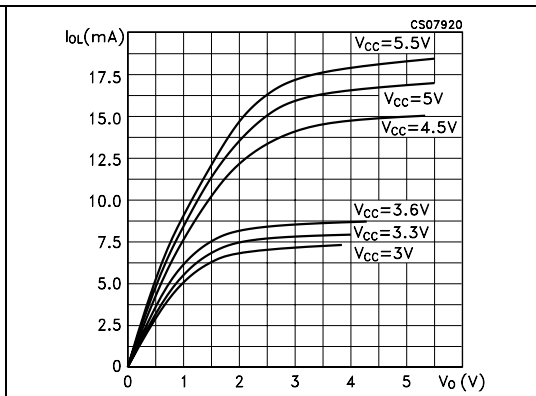

**Figure 6. ESD Protection**

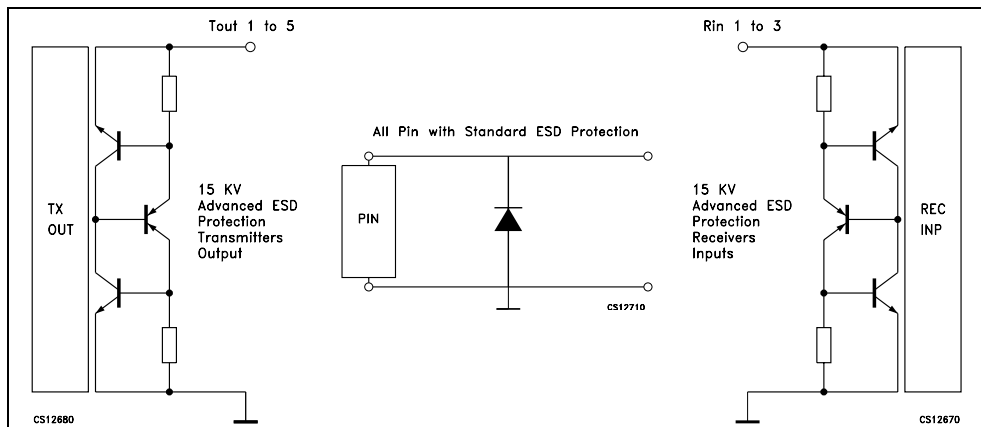

*Note:* The High ESD protected pins are the I/O RS232 line, transmitter out and receiver in. The other pins guarantee  $\pm 2\text{KV}$  HBM ESD protection versus ground by means of diodes.

## 6 Application note

This application note describes the procedure for determining the susceptibility and the test method to verify ST ESD advanced protection on RS-232 or RS485 I/O device.

Static electricity is defined as an electrical charge caused by an imbalance of electrons on the surface of a material. This imbalance of electrons produces an electric field that can be measured and that can influence other objects at a distance. Electrostatic discharge is defined as the transfer of charge between bodies at different electrical potentials. Electrostatic discharge (ESD) can change the electrical characteristics of a semiconductor device, degrading or destroying it. Any input or output port (I/O) allows access communication with other pieces of equipment by external connectors. These connectors are directly linked by the I/O pins of RS-232 or RS485 interface. ST provides the E-series by advanced high ESD protection structure. The protection functionality is tested in two different conditions:

The first model is used to simulate the HUMAN BODY MODEL (HBM) event. A similar discharge can occur from a charged conductive object, such as a metallic tool or fixture. The model used to characterize this event is known as the Machine Model. A Human Body Model circuit and waveform is presented in Figures below.

**Figure 7. Human body model circuit**

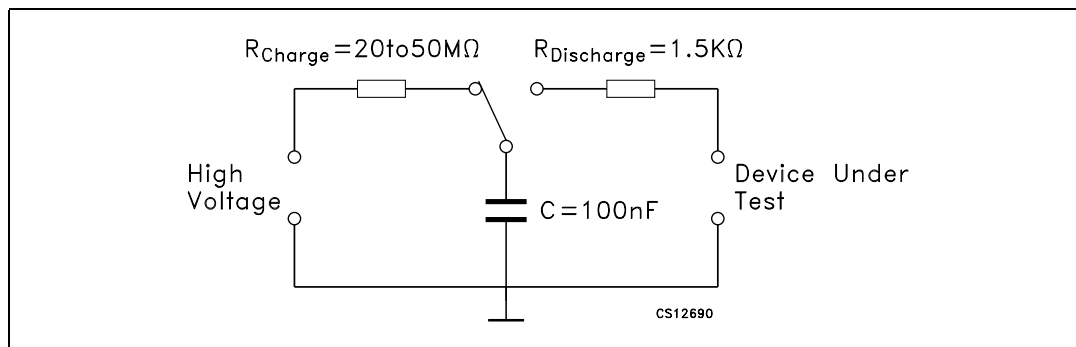

**Figure 8. Human body model current waveform**

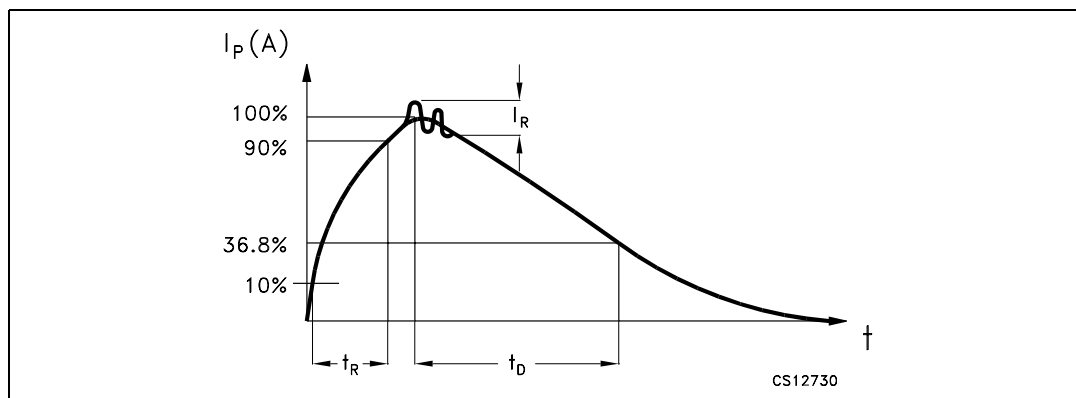

The second model is IEC 1000-4-2 and is used to simulate the reaction of the device on equipment when subjected to electrostatic discharges, which may occur from personnel to objects near vital instrumentation. Direct (Contact) and indirect (Air Gap) applications of discharges to the equipment under test (EUT) are possible. Test characteristics are shown in circuit, waveform and table below.

Figure 9. IEC 1000-4-2 circuit

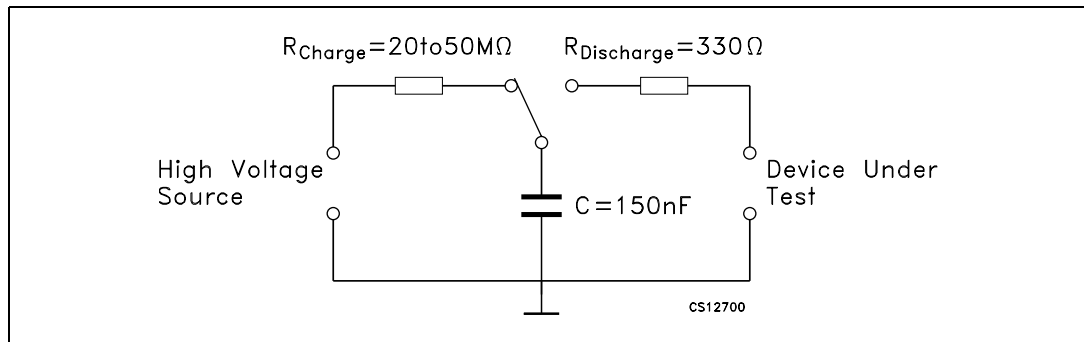

Figure 10. IEC 1000-4-2 current waveform

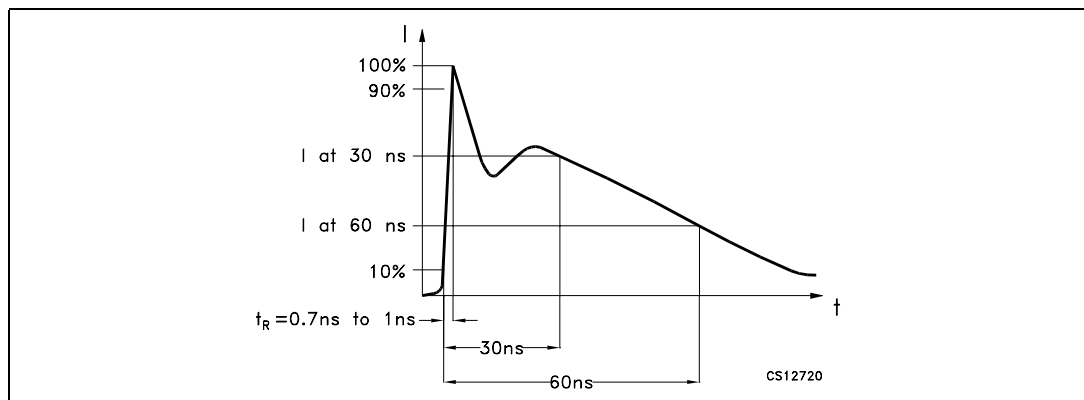
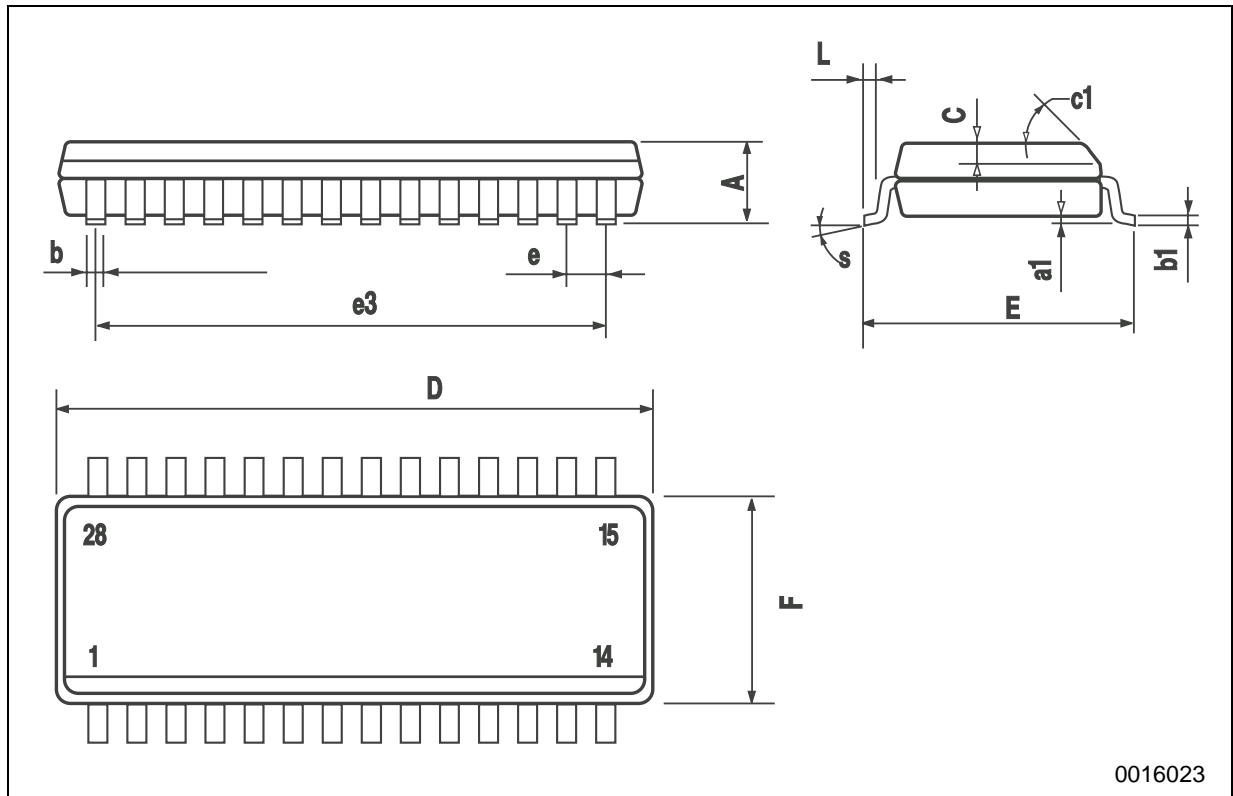

Table 10. Characteristics of the ESD generator

Level	Indicated voltage	First peak current of discharge ( $\pm 10\%$ )	Rise time with discharge switch	Current at 30 ns ( $\pm 30\%$ )	Current at 60 ns ( $\pm 30\%$ )
1	2 KV	7.5 A	0.7 to 1ns	4 A	2 A
2	4 KV	15 A	0.7 to 1ns	8 A	4 A
3	6 KV	22.5 A	0.7 to 1ns	12 A	6 A
4	8 KV	30 A	0.7 to 1ns	16 A	8 A

**SO-28 MECHANICAL DATA**

DIM.	mm.			inch		
	MIN.	TYP	MAX.	MIN.	TYP.	MAX.
A			2.65			0.104
a1	0.1		0.3	0.004		0.012
b	0.35		0.49	0.014		0.019
b1	0.23		0.32	0.009		0.012
C		0.5			0.020	
c1	45° (typ.)					
D	17.70		18.10	0.697		0.713
E	10.00		10.65	0.393		0.419
e		1.27			0.050	
e3		16.51			0.650	
F	7.40		7.60	0.291		0.300
L	0.50		1.27	0.020		0.050
S	8° (max.)					



0016023

**SSOP28 MECHANICAL DATA**

DIM.	mm.			inch		
	MIN.	TYP	MAX.	MIN.	TYP.	MAX.
A			2			0.079
A1	0.050			0.002		
A2	1.65	1.75	1.85	0.065	0.069	0.073
b	0.22		0.38	0.009		0.015
c	0.09		0.25	0.004		0.010
D	9.9	10.2	10.5	0.390	0.402	0.413
E	7.4	7.8	8.2	0.291	0.307	0.323
E1	5	5.3	5.6	0.197	0.209	0.220
e		0.65 BSC			0.0256 BSC	
K	0°		10°	0°		10°
L	0.55	0.75	0.95	0.022	0.030	0.037

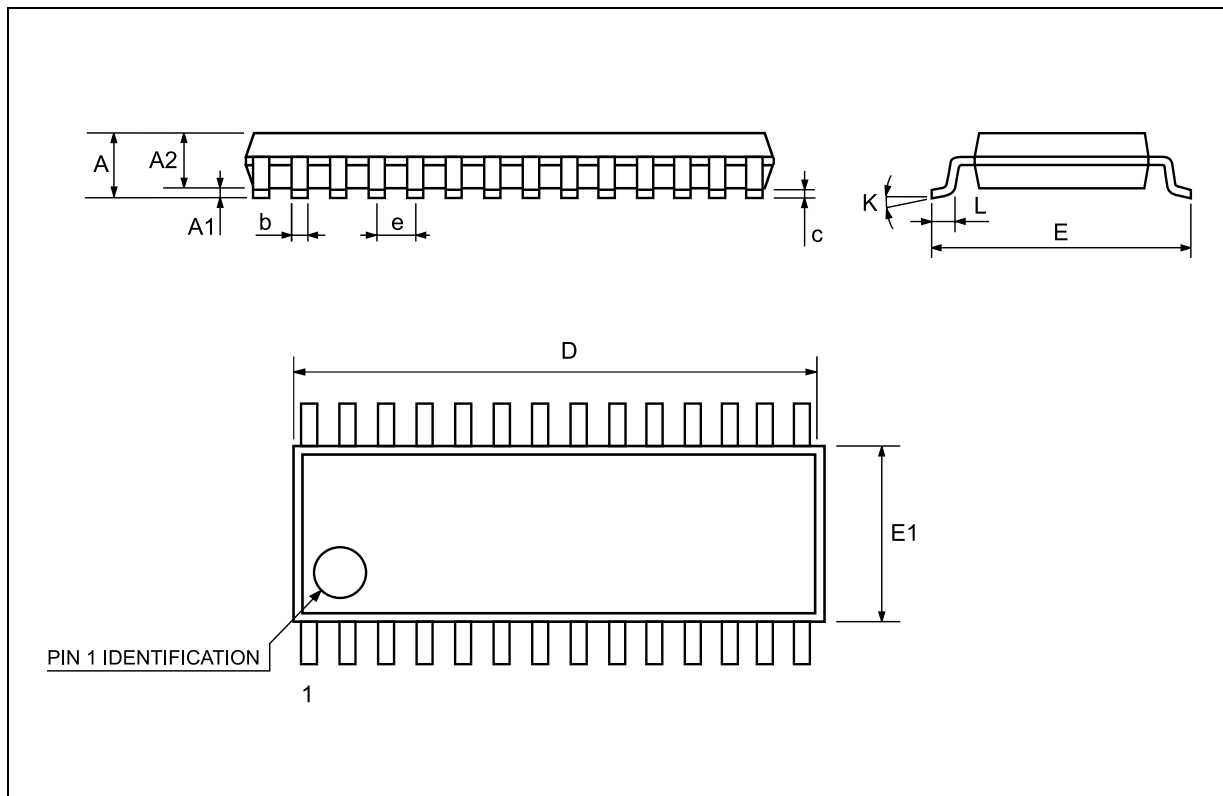

**Tape & Reel SO-28 MECHANICAL DATA**

DIM.	mm.			inch		
	MIN.	TYP	MAX.	MIN.	TYP.	MAX.
A			330			12.992
C	12.8		13.2	0.504		0.519
D	20.2			0.795		
N	60			2.362		
T			30.4			1.197
Ao	10.8		11.0	0.425		0.433
Bo	18.2		18.4	0.716		0.724
Ko	2.9		3.1	0.114		0.122
Po	3.9		4.1	0.153		0.161
P	11.9		12.1	0.468		0.476

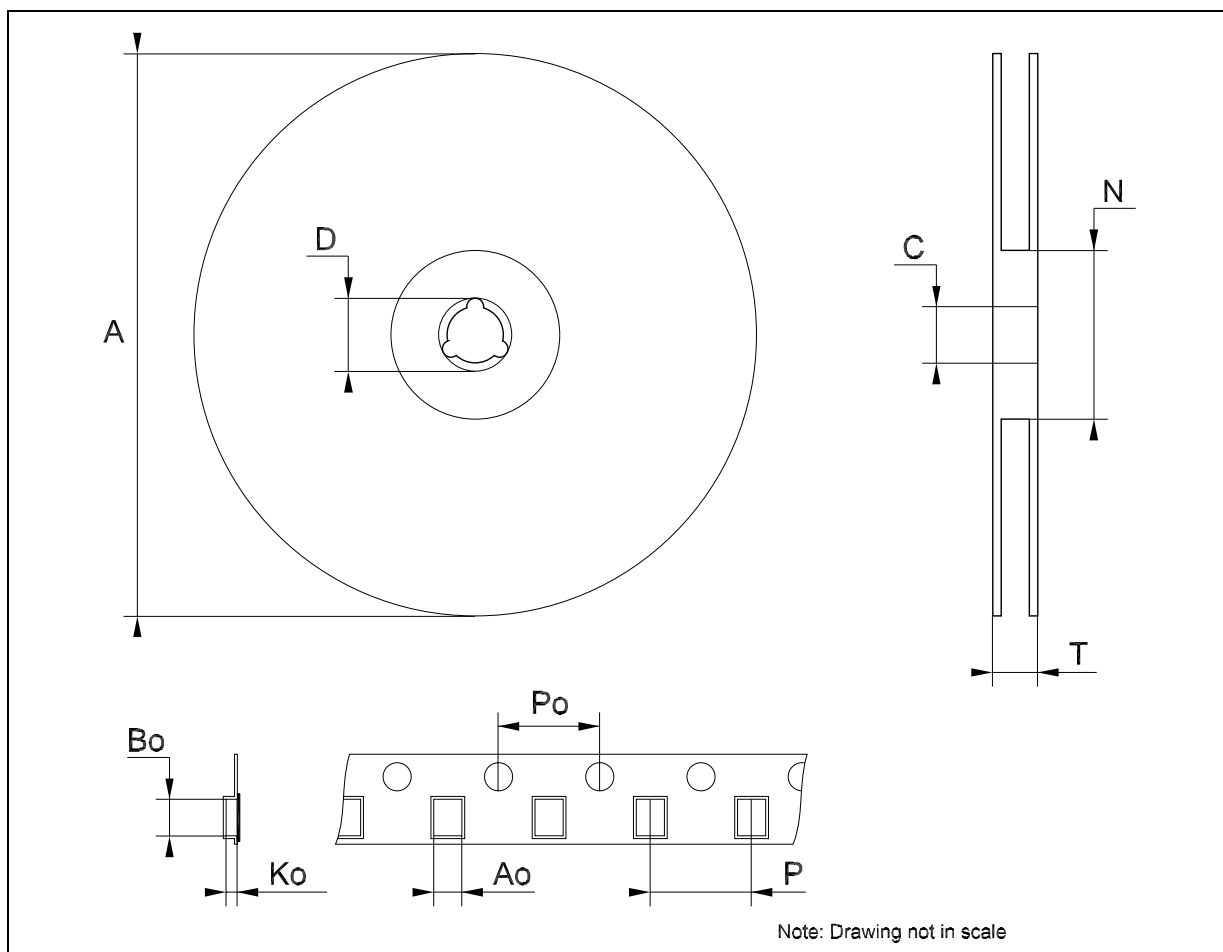

**Tape & Reel SSOP28 MECHANICAL DATA**

DIM.	mm.			inch		
	MIN.	TYP	MAX.	MIN.	TYP.	MAX.
A			330			12.992
C	12.8		13.2	0.504		0.519
D	20.2			0.795		
N	60			2.362		
T			22.4			0.882
Ao	8.4		8.6	0.331		0.339
Bo	10.7		10.9	0.421		0.429
Ko	2.9		3.1	0.114		0.122
Po	3.9		4.1	0.153		0.161
P	11.9		12.1	0.468		0.476

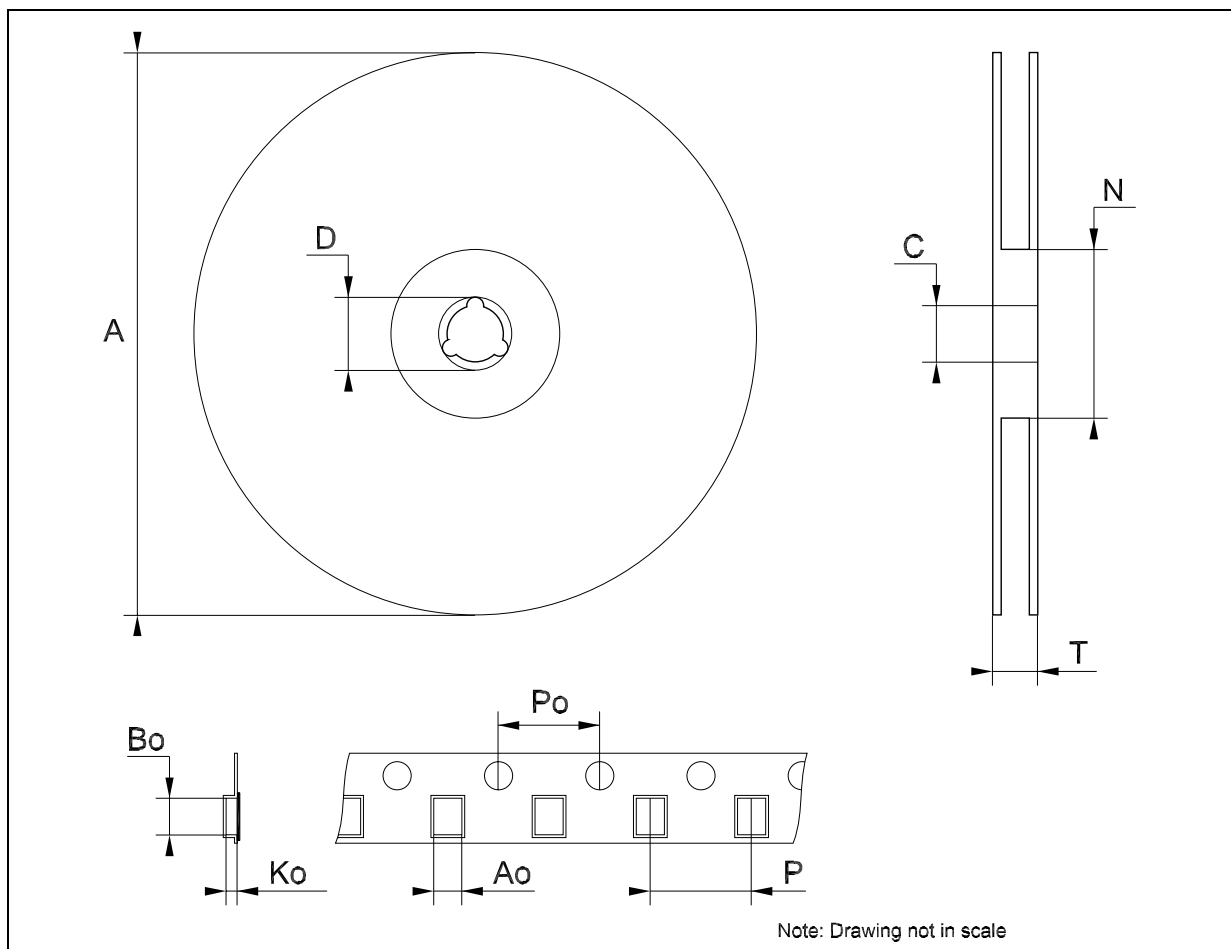

## 7 Revision history

**Table 11. Revision history**

Date	Revision	Changes
21-Mar-2005	5	TSSOP has been removed.
24-Mar-2006	6	Order codes has been updated and new template.



**Please Read Carefully:**

Information in this document is provided solely in connection with ST products. STMicroelectronics NV and its subsidiaries ("ST") reserve the right to make changes, corrections, modifications or improvements, to this document, and the products and services described herein at any time, without notice.

All ST products are sold pursuant to ST's terms and conditions of sale.

Purchasers are solely responsible for the choice, selection and use of the ST products and services described herein, and ST assumes no liability whatsoever relating to the choice, selection or use of the ST products and services described herein.

No license, express or implied, by estoppel or otherwise, to any intellectual property rights is granted under this document. If any part of this document refers to any third party products or services it shall not be deemed a license grant by ST for the use of such third party products or services, or any intellectual property contained therein or considered as a warranty covering the use in any manner whatsoever of such third party products or services or any intellectual property contained therein.

**UNLESS OTHERWISE SET FORTH IN ST'S TERMS AND CONDITIONS OF SALE ST DISCLAIMS ANY EXPRESS OR IMPLIED WARRANTY WITH RESPECT TO THE USE AND/OR SALE OF ST PRODUCTS INCLUDING WITHOUT LIMITATION IMPLIED WARRANTIES OF MERCHANTABILITY, FITNESS FOR A PARTICULAR PURPOSE (AND THEIR EQUIVALENTS UNDER THE LAWS OF ANY JURISDICTION), OR INFRINGEMENT OF ANY PATENT, COPYRIGHT OR OTHER INTELLECTUAL PROPERTY RIGHT.**

**UNLESS EXPRESSLY APPROVED IN WRITING BY AN AUTHORIZED REPRESENTATIVE OF ST, ST PRODUCTS ARE NOT DESIGNED, AUTHORIZED OR WARRANTED FOR USE IN MILITARY, AIR CRAFT, SPACE, LIFE SAVING, OR LIFE SUSTAINING APPLICATIONS, NOR IN PRODUCTS OR SYSTEMS, WHERE FAILURE OR MALFUNCTION MAY RESULT IN PERSONAL INJURY, DEATH, OR SEVERE PROPERTY OR ENVIRONMENTAL DAMAGE.**

Resale of ST products with provisions different from the statements and/or technical features set forth in this document shall immediately void any warranty granted by ST for the ST product or service described herein and shall not create or extend in any manner whatsoever, any liability of ST.

ST and the ST logo are trademarks or registered trademarks of ST in various countries.

Information in this document supersedes and replaces all information previously supplied.

The ST logo is a registered trademark of STMicroelectronics. All other names are the property of their respective owners.

© 2006 STMicroelectronics - All rights reserved

STMicroelectronics group of companies

Australia - Belgium - Brazil - Canada - China - Czech Republic - Finland - France - Germany - Hong Kong - India - Israel - Italy - Japan - Malaysia - Malta - Morocco - Singapore - Spain - Sweden - Switzerland - United Kingdom - United States of America

[www.st.com](http://www.st.com)